

E3-07659D-01

Position	Numéro de pièce	#	Appellation I	Appellation II
1	619-04183B	1	CORPS DE PALIER	FINISH:WIE GEGOSSEN
2	712-0417A	1	ÛCROU HEX. AV. FLANC: 5/8-18	FINISH:MTD STD 701-01000
3	736-0351	1	RONDELLE .75x1.50"	FINISH:BLAU VERZINKT 936-0351
4	738-1186A	1	AXE DE PALIER DE LAME	FINISH:GEÖLT
5	741-0919B	2	ROULEMENT DE PALIER DE LAME	FINISH:
6	750-04936	1	ENTRETOISE	FINISH:GEÖLT
7	750-06390	1	ENTRETOISE	FINISH:GEÖLT
8	756-05111	1	POULIE DE PALIER DE LAME	FINISH:SPEC-100015
9	618-04822B	1	PALIER DE LAME COMPLET	Ø 6.3":FINISH 918-04822B
10	783-08435	1	PROTECTION DE ROULEMENT	FINISH:SCHWARZ PHOSPHATIERT

www.emc-motoculture.com

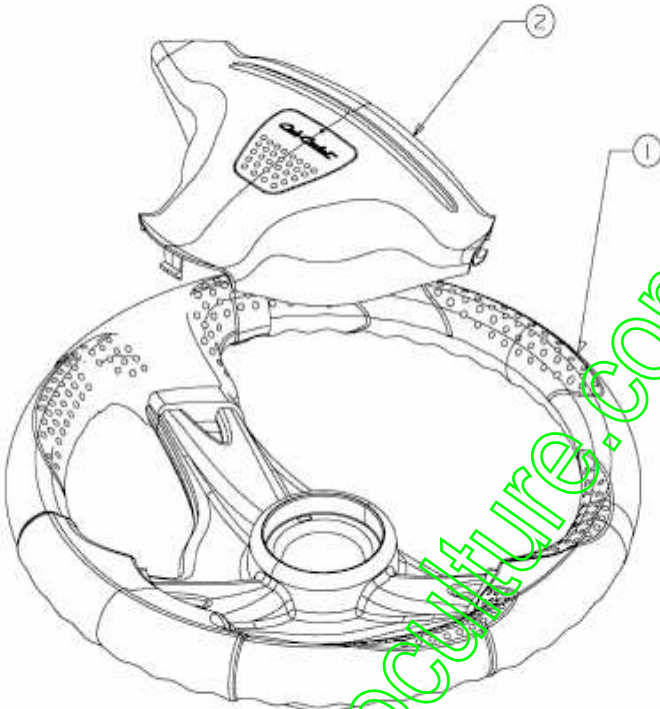

E3-04518B-01

Position	Numéro de pièce	#	Appellation I	Appellation II
1	631-04008A	1	VOLANT CPL.:3 RAYONS:12"	SOFTGRIP
2	731-04532B	1	COUVERCLE DE VOLANT	FINISH:

www.emc-motoculture.com

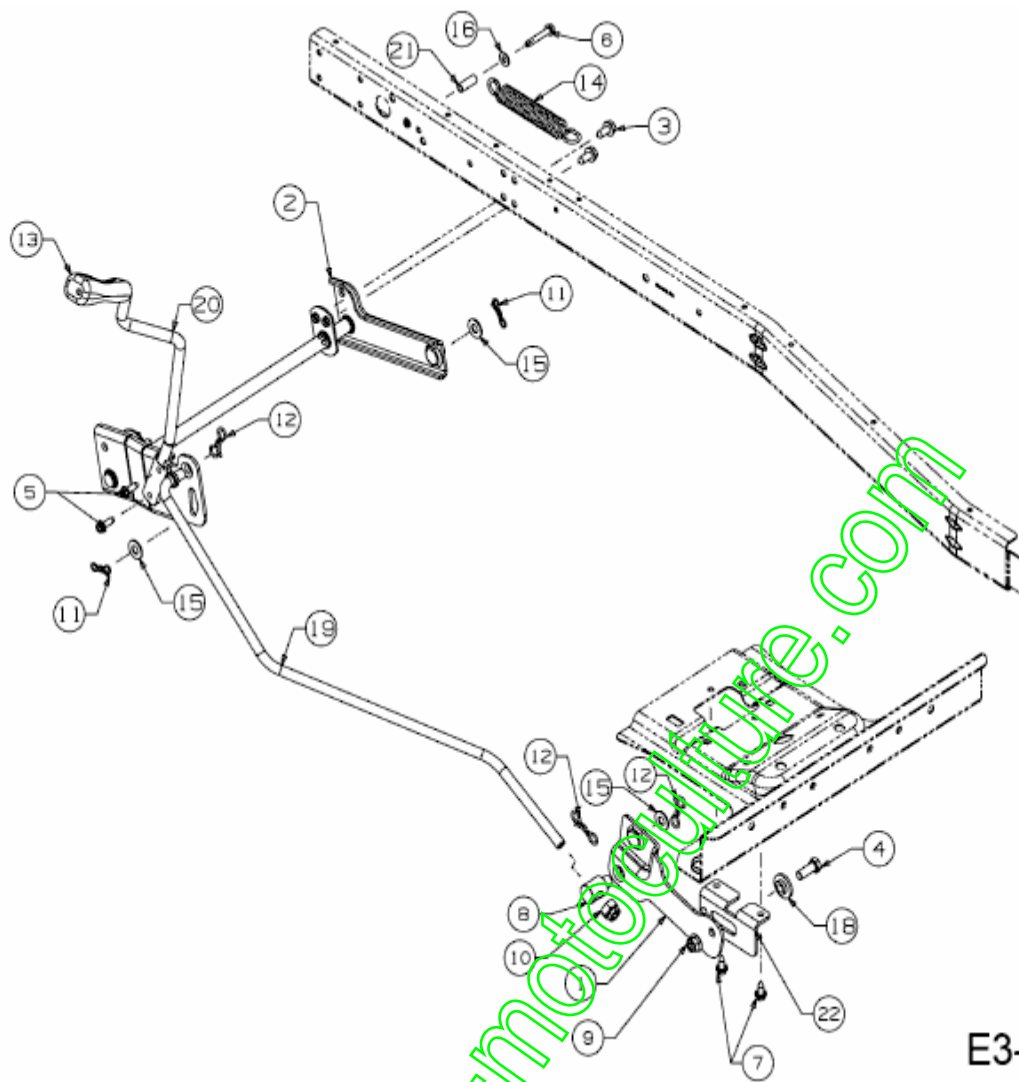

E3-07633D-01

www.emc-motoculture.com

Position	Numéro de pièce	#	Appellation I	Appellation II
1	683-04757	1		
2	683-05060	1		
3	710-04484	4	VIS HEX. TT:5/16-18:.750:HXIND	FINISH:MTD SPEC-701-01002
4	710-0514	1	VIS HEX.:3/8-16:1.00:GR5:STD	FINISH:MTD STD 701-01000
5	710-0642	2	VIS1/4-20:0.750	MTD SPEC-701-01002 910-0642
6	710-0778	1	VIS HEX. TT:1/4-20:1.500	FINISH:MTD SPEC-701-01002
7	710-1652	2	VIS HEX. TT:1/4-20:.625:HXINDW	FINISH:MTD-SPEC-701-01002
8	711-05690C	1	FERRURE	711-05690C
9	712-04065	1	ÛCROU HEXAGONAL	FINISH:SPEC-101616 912-04065
10	712-04243	1	ECROU	FINISH:MTD STD 701-01000
11	714-04040	2	GOUPILLE	FINISH:VERZINKT
12	714-04043	3	GOUPILLE	FINISH:VERZINKT
13	720-0311	1	POIGNÛE: 1/2	FARBE: SCHWARZ VINYL
14	732-04692	1	RESSORT	FINISH:PHOS & OIL
15	736-0300	3	RONDELLE	FINISH:MTD SPEC-100015
16	736-0463	1	RONDELLE	FINISH:MTD STD 701-01000
18	738-0347	1	RONDELLE; EMB. .625IDx.169	FINISH:
19	747-05511	1	TRINGLE DE RELEVAGE	747-05511
20	747-05576	1		
21	750-0566A	1	ENTRETOISE	FINISH:VERZINKT SIEHE ZG.
22	783-07129	1		

www.encyclicmotoculture.com

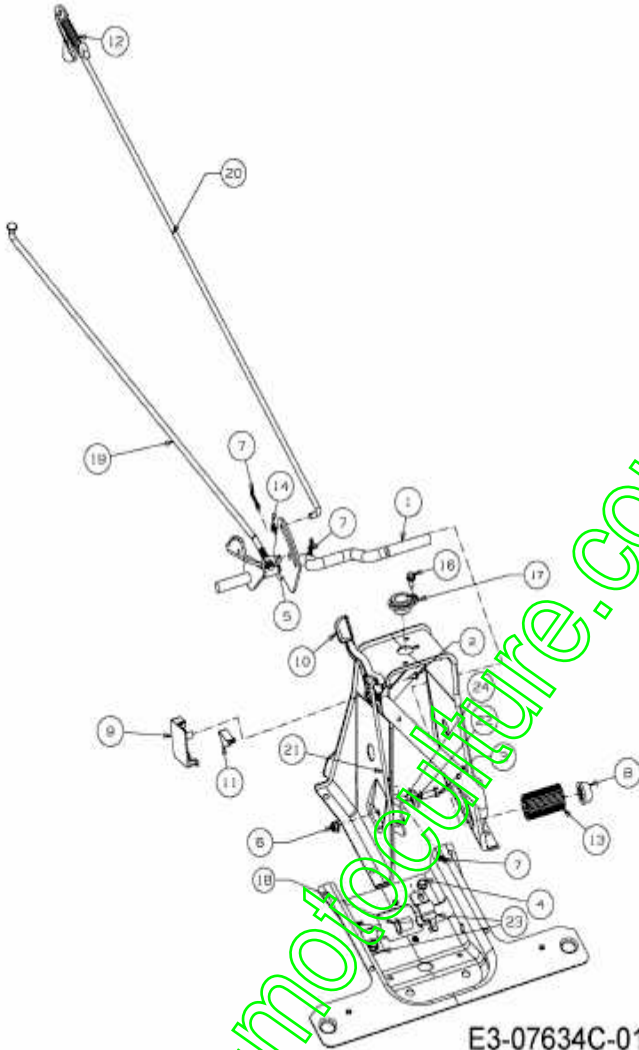

Position	Numéro de lapièce	#	Appellation I	Appellation II
1	683-05017	1		
2	710-0224	1	VIS PARK:#10- 16:0.500:HXINDWSH	FINISH:MTD STD 701- 01002
3	710-0376	1	VIS HEX.:5/16- 18:1.00:GR5:STD	FINISH:MTD STD 701- 01000
4	710-04484	2	VIS HEX. TT:5/16- 18.:750:HXIND	FINISH:MTD SPEC-701- 01002
5	711-06103	1	FERRURE	FINISH:MTD SPEC 701- 01000
6	712-04063	1	ÜCROU HEX. AVEC FLANC	FINISH:MTD STD SPEC- 101616
7	714-04040	3	GOUPILLE	FINISH:VERZINKT
8	726-0214	1	BOUCHON	FINISH:SCHWARZ
9	731-08656A	1	COUVERCLE POIGNEE DE VITESSE	731-08656A
10	731-08743B	1	LEVIER SELECTEUR	731-08743B
11	732-04937	1	RESSORT DE VERROUILLAGE	FINISH:SPEC-100015
12	732-0716D	1	RESSORT	FINISH:MTD STD 701- 01006
13	735-04279	1	CAOUTCHOUC DE PEDALE	735-04279
14	736-0264	1	RONDELLE: .330 x.630 x.0635	FINISH:701-01000 936-0264
16	738-04184A	1	VIS i ÜPAULE:.368x.113:TT:1/4-	:1/4-20 / FINISH:701-01002
17	741-0356A	1	BAGUE DE VOLANT	FINISH:KUNSTSTOFF SCHWARZ
18	741-05135	1	FLANSCHLAGER .626X.938X.875	741-05135
19	747-05506	1	TRINGLE	747-05506
20	747-06033A	1	TRINGLE DE FREIN	747-06033A
21	747-06449	1	TRINGLE SELECTION DE VITESSE	747-06449
22	748-0234	1	RONDELLE EPAULEE	FINISH:ROSTPREVENTION
23	783-05940	2	SUPPORT	FINISH:MTD SPEC-100015
24	783-08116B	1		

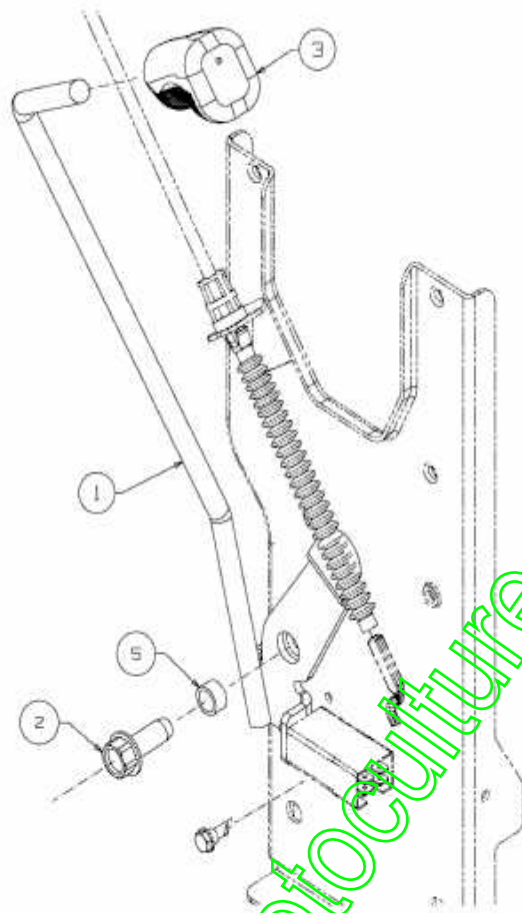

E3-07636B-01

www.emc-motoculture.com

Position	Numéro de lapièce	#	Appellation I	Appellation II
1	683-04754	1		
2	710-04683	1	VIS HEX.:3/8-16:1.000	FINISH:MTD SPEC-701- 01002
3	720-04049A	1	POIGNEE PLASTIQUE	FINISH:SCHWARZ
5	750-0526	1	ENTRETOISE 380 IDX 50 ODX 265	FINISH:GLANZVERZINKT

www.emc-motoculture.com

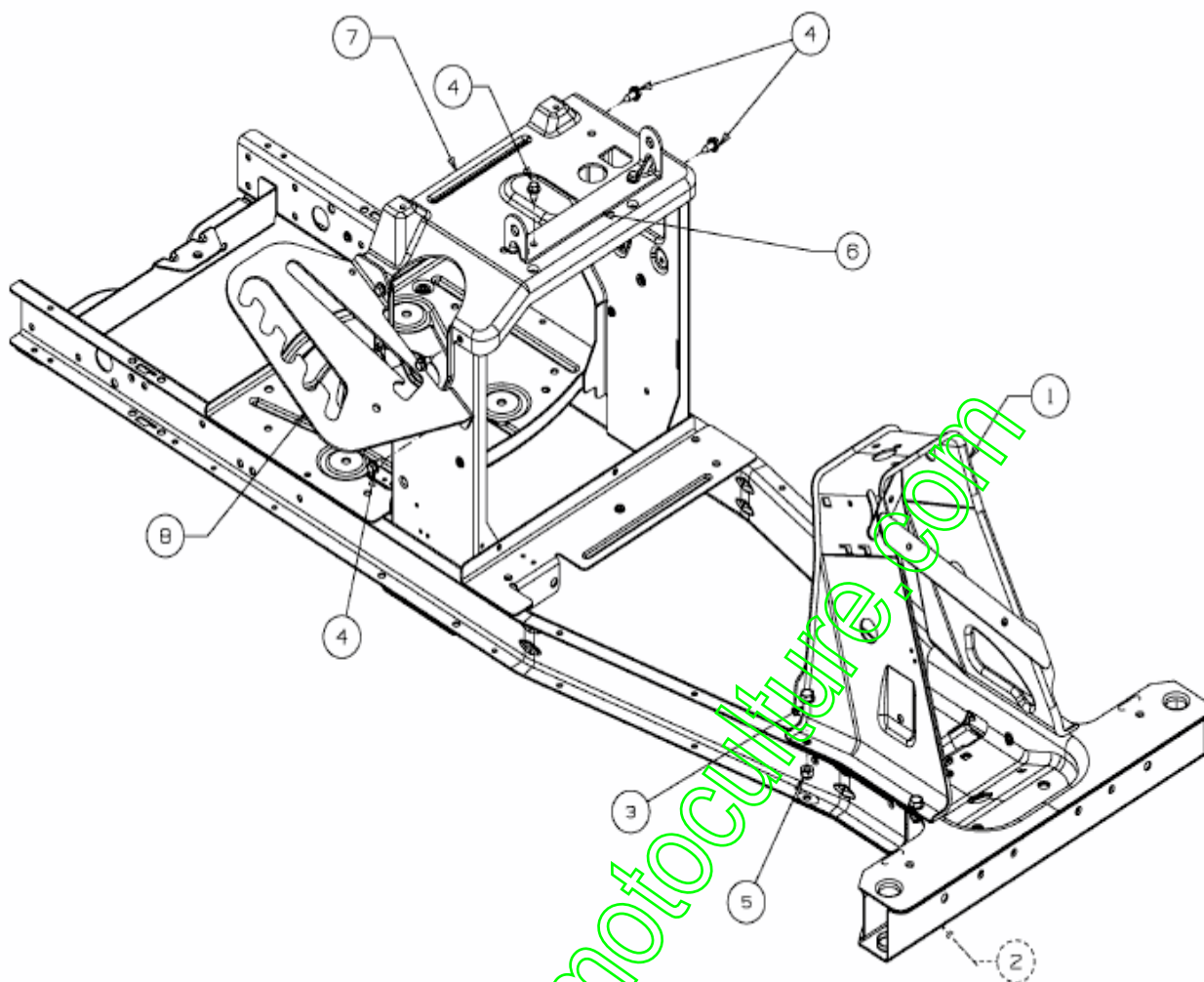

E3-07639D-01

Position	Numéro de lapièce	#	Appellation I	Appellation II
1	683-05167637	1	SOCLE DE COLONNE	683-05167637
2	683-05189637	1	CHASSIS	683-05189637
3	710-06194	4	VIS	710-06194
4	710-1652	9	VIS HEX. TT:1/4- 20:.625:HXINDW	FINISH:MTD-SPEC-701- 01002
5	712-0429	4	ÜCROU	FINISH:701-01000
6	783-07168637	1	SUPPORT	783-07168637 *
7	783-08197	1	SUPPORT SIEGE	783-08197
8	783-08260637	1	PLAQUE SELECTEUR HAUTEUR DE	783-08260637

www.emc-motoculture.com

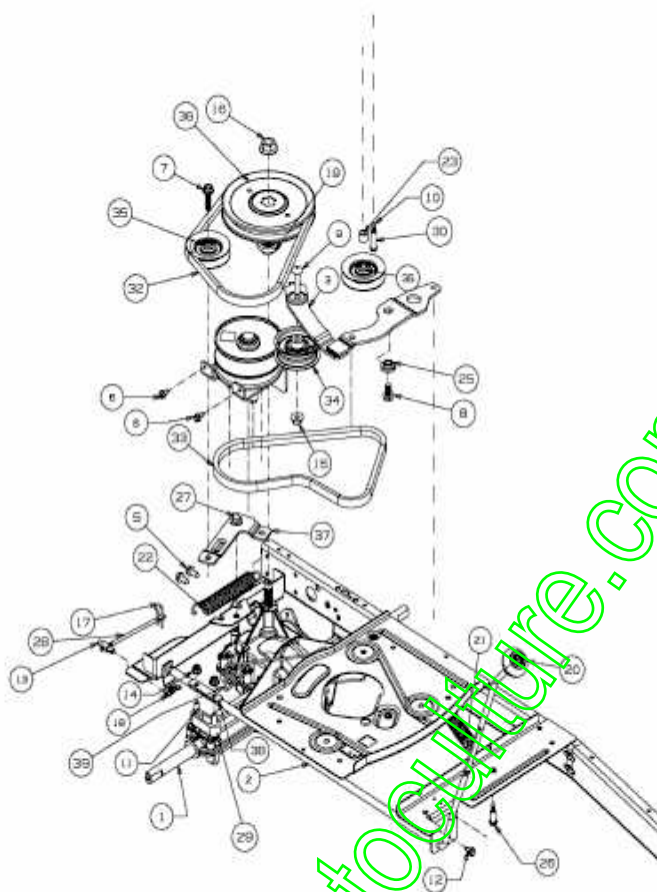

E3-07641C-01

www.emc-motoculture.com

Position	Numéro de lapièce	#	Appellation I	Appellation II
1	618-05056B	1	PONT COMPLET	618-05056B
2	647-04262D	1	LEVIER INVERSEUR	647-04262D
3	683-04768A	1		
5	710-04484	2	VIS HEX. TT:5/16- 18:.750:HXIND	FINISH:MTD SPEC-701- 01002
6	710-0599	2	VIS $\dot{\text{I}}$ SIX PANS CREUX	MTD SPEC-701-01002 or 101617
7	710-06016	1	VIS	710-06016
8	710-0623	1	VIS PARK. HEX.:TT:3/8- 16:0.750	FINISH:MTD SPEC-701- 01002
9	710-06234	1	VIS	710-06234
10	710-1026	1	VIS HEX:TT:1/4-20:1.750	FINISH:MTD-SPEC-100016
11	710-1266	4	VIS HHCS:5/16- 18:3.5:GR5:STD	FINISH:MTD STD 701- 01000
12	710-1652	1	VIS HEX. TT:1/4- 20:.625:HXINDW	FINISH:MTD-SPEC-701- 01002
13	711-06141	1	FERRURE	711-06141
14	712-04063	4	ÜCROU HEX. AVEC FLANC	FINISH:MTD STD SPEC- 101616
15	712-04217	1	ÜCROU	FINISH:MTD STD 701- 01000
16	712-0700	1	ÜCROU HEXAGONAL	FINISH:701-01000 912-0700
17	714-0209	1	GOUPILLE FENDUE	FINISH:GELBVERZINKT 914-0209
18	714-04040	1	GOUPILLE	FINISH:VERZINKT
19	718-04407	1	MOYEU: POULIE:5/8 DENTELURE	VERZAHNUNG
20	720-04028	1	POIGNEE INVERSEUR	FINISH:SCHWARZ
21	732-0459C	1	RESSORT	FINISH:MTD SPEC-100015
22	732-04934	1	RESSORT	732-04934
23	750-05563	1	ENTRETOISE	750-05563
25	738-0372B	1	RONDELLE EPAULEE	FINISH:GEÖLT
26	738-05016	1	VIS EPAULEE	738-05016
27	738-05019	1	VIS EPAULEE	738-05019
28	747-05593	1	TRINGLE	747-05593
29	748-0334	2	ENTRETOISE	FINISH:GEÖLT
30	750-04456	1	ENTRETOISE	FINISH:VERZINKT SIEHE ZG.
32	754-0241A	1	COURROIE VARIATEUR/BOITE	FINISH:SIEHE ZG. 954- 0241A
33	754-04331	1	COURROIE	FINISH: SIEHE CHART
34	756-04224	1	POULIE TENDEUR	FINISH:SIEHE ZG.
35	756-04325	2	POULIE TENDEUR	FINISH:SCHWARZ LACKIERT
36	756-04464	1	POULIE DE PONT	FINISH:SIEHE ZG.
37	783-07248A	1	SUPPORT	783-07248A
38	783-08131	2		

Position	Numéro de lapièce	#	Appellation I	Appellation II
39	732-05060	1	GUIDE COURROIE	732-05060

www.emc-motoculture.com

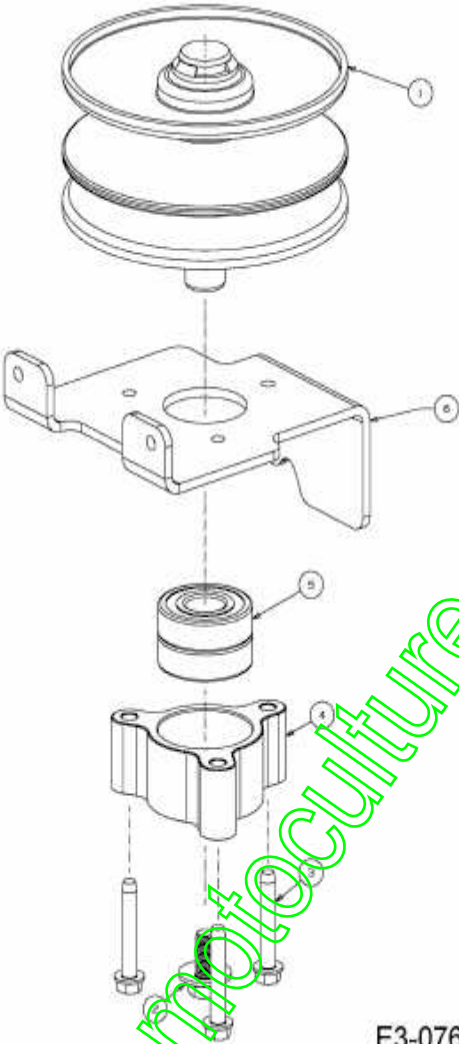

E3-07641C-02

Position	Numéro de lapièce	#	Appellation I	Appellation II
1	656-04015A	1	POULIE VARIATEUR	FINISH:
2	710-05339	1	VIS	GR5 E-TEIL-SET
3	710-0778	3	VIS HEX. TT:1/4- 20:1.500	FINISH:MTD SPEC-701-01002
4	718-04261	1	CAGE DE ROULEMENT	FINISH:ROSTSCHUTZ SIEHE ZG.
5	741-0124A	2	ROULEMENT A BILLE	FINISH:
6	783-08210	1		

www.emc-motoculture.com

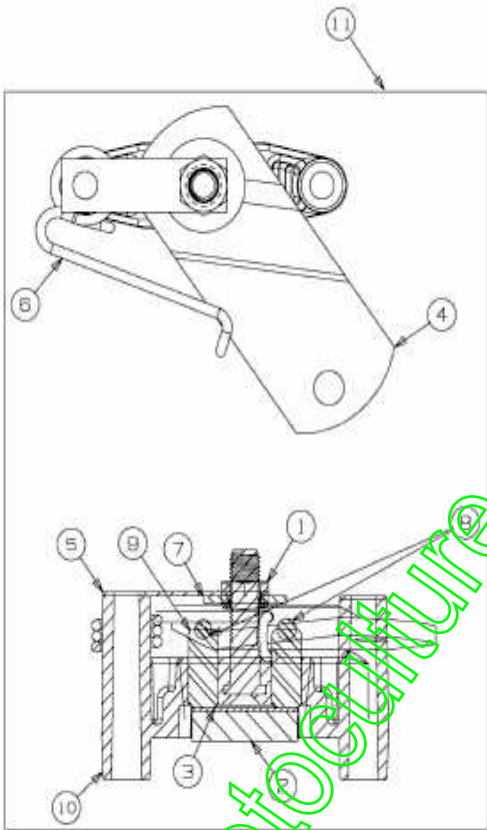

E3-07641C-03

www.emc-motoculture.com

Position	Numéro de pièce	#	Appellation I	Appellation II
1	712-0273	1	ÛCROU HEXAGONAL 5/16-24"	FINISH:MTD STD 701-01000
2	717-0678	1	PLAQUETTE DE FREIN	FINISH:
3	717-0682	1	INSERT DE FREIN	FINISH:NONE 917-0682
4	717-0700	1	LEVIER DE FREIN, i DROITE	FINISH:PHOSPHATE & OIL
5	718-0150	1	LANG. DE SUPP.: ANTI ROTATION	FINISH:SPEC-100015
6	732-0742	1	RESSORT	FINISH:SPEC-100016 932-0742
7	736-0371	1	RONDELLE 1.344XA .875"	FINISH:701-01001
9	741-0343	2	GOUJON DE PRESSION 5/16"	FINISH:SIEHE ZG. 941-0343
10	761-0198A	1	APPUI DE FREIN	FINISH:NONE 961-0198A
11	661-0006	1	SUPPORT PLAQUETTE FREIN	FINISH:

www.emc-motoculture.com

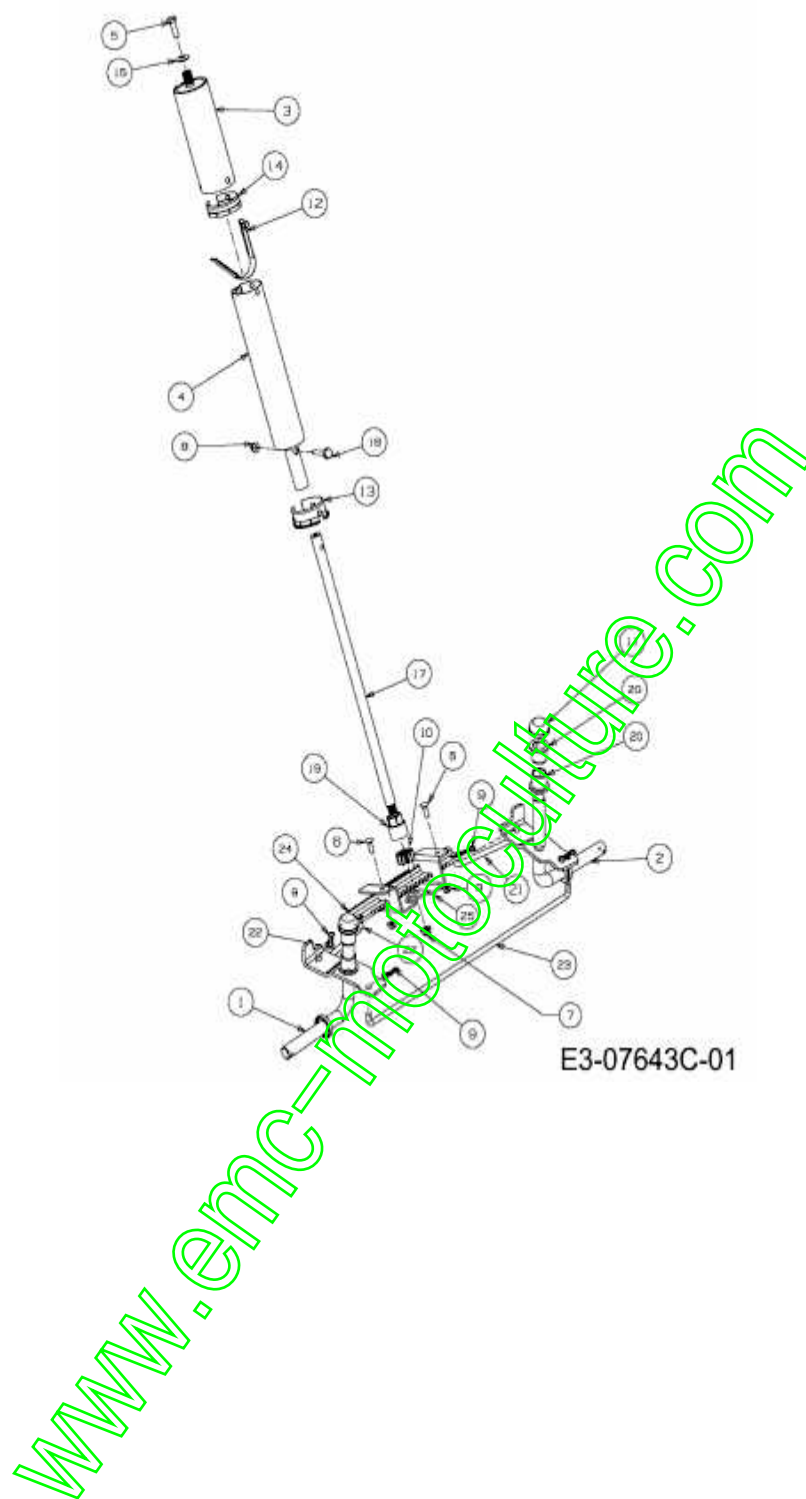

E3-07643C-01

Position	Numéro de lapièce	#	Appellation I	Appellation II
1	683-04726	1		
2	683-04727	1		
3	683-04761	1	MANCHON SUPERIEUR DE DIRECTION	683-04761
4	683-04762	1	MANCHON INFERIEUR DE DIRECTION	683-04762
5	710-0643	1	VIS HEX.: 5/16-18:1.00:GR5	FINISH: MTD STD 701- 01000
6	710-0703	2	VIS	FINISH:MTD STD 701- 01000
7	712-04063	1	ÜCROU HEX. AVEC FLANC	FINISH:MTD STD SPEC- 101616
8	712-04064	3	ÜCROU HEXAGONAL	GRF FINISH:701-01000 912-04064
9	714-04040	4	GOUPILLE	FINISH:VERZINKT
10	717-1554	1	PIGNON DE DIRECTION	FINISH:GEÖLT
11	726-0341	2	CAPUCHON CLIPS	FINISH:SCHWARZ
12	726-04127	1	COLLIER	726-04127
13	731-08690	1	BAGUE	731-08690
14	731-08691	1	BAGUE DE CENTRAGE	731-08691
15	736-0242	1	RONDELLE CONIQUE.340X.872X.060	FINISH:MTD STD 701- 01001
17	738-04537A	1	COLONNE DE DIRECTION	738-04537A
18	738-05000	1	VIS EPAULEE	738-05000
19	741-04542A	1	BAGUE	741-04542A
20	741-0660A	4	BAGUE	FINISH:KUNSTSTOFF SCHWARZ
21	747-05514	1	TIGE DE DIRECTION GAUCHE	747-05514
22	747-05585	1	TIGE DE DIRECTION DROITE	747-05585
23	747-06027	1	TRINGLE DE DIRECTION	BLACK E-COAT o.SPEC- 701-01000
24	783-06988A	1	CREMAILLERE DE DIRECTION	783-06988A
25	783-07239	1	SUPPORT DE DIRECTION	783-07239

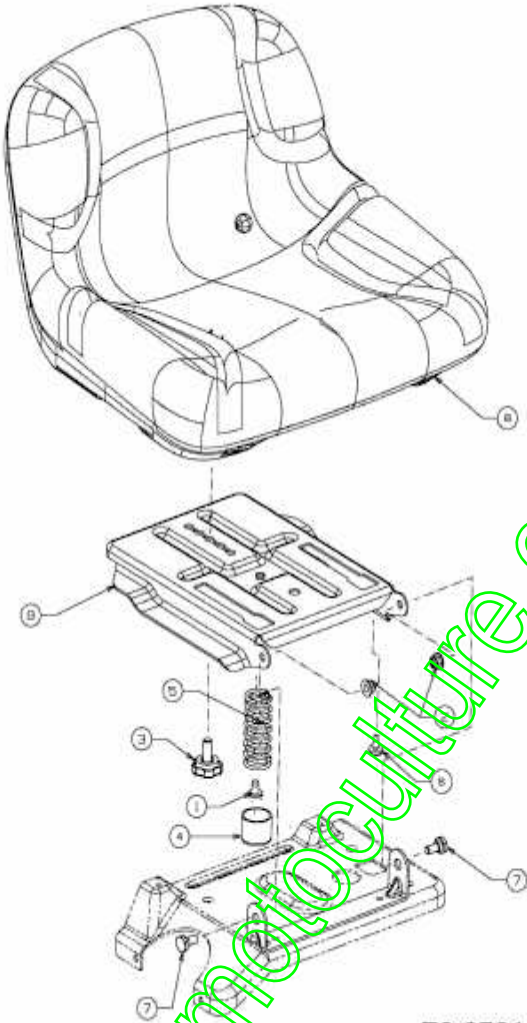

E3-07644B-01

Position	Numéro de lapièce	#	Appellation I	Appellation II
1	710-0607	1	VIS HEX.TT5/16- 18:..500HXINDWSh	FINISH:MTD SPEC-701- 01002
2	712-04063	2	ÜCROU HEX. AVEC FLANC	FINISH:MTD STD SPEC- 101616
3	720-04009A	1	MOLETTE DE SIEGE	FINISH:SCHWARZ *
4	720-05005	1	PROTECTION DE RESSORT	720-05005
5	732-04905	1	RESSORT DE SIEGE	FINISH:SPEC-100015
6	735-0199A	1	BOUCHON EN CAOUTCH.:.62ODx.22	FINISH:SCHWARZ 935- 0199A
7	738-0140	2	VIS j ÜP.:.435 x.178-5/16 x.56	FINISH:VERZINKT
8	757-04083A	1	SIEGE	757-04083A
9	783-07213A	1		

www.emc-motoculture.com

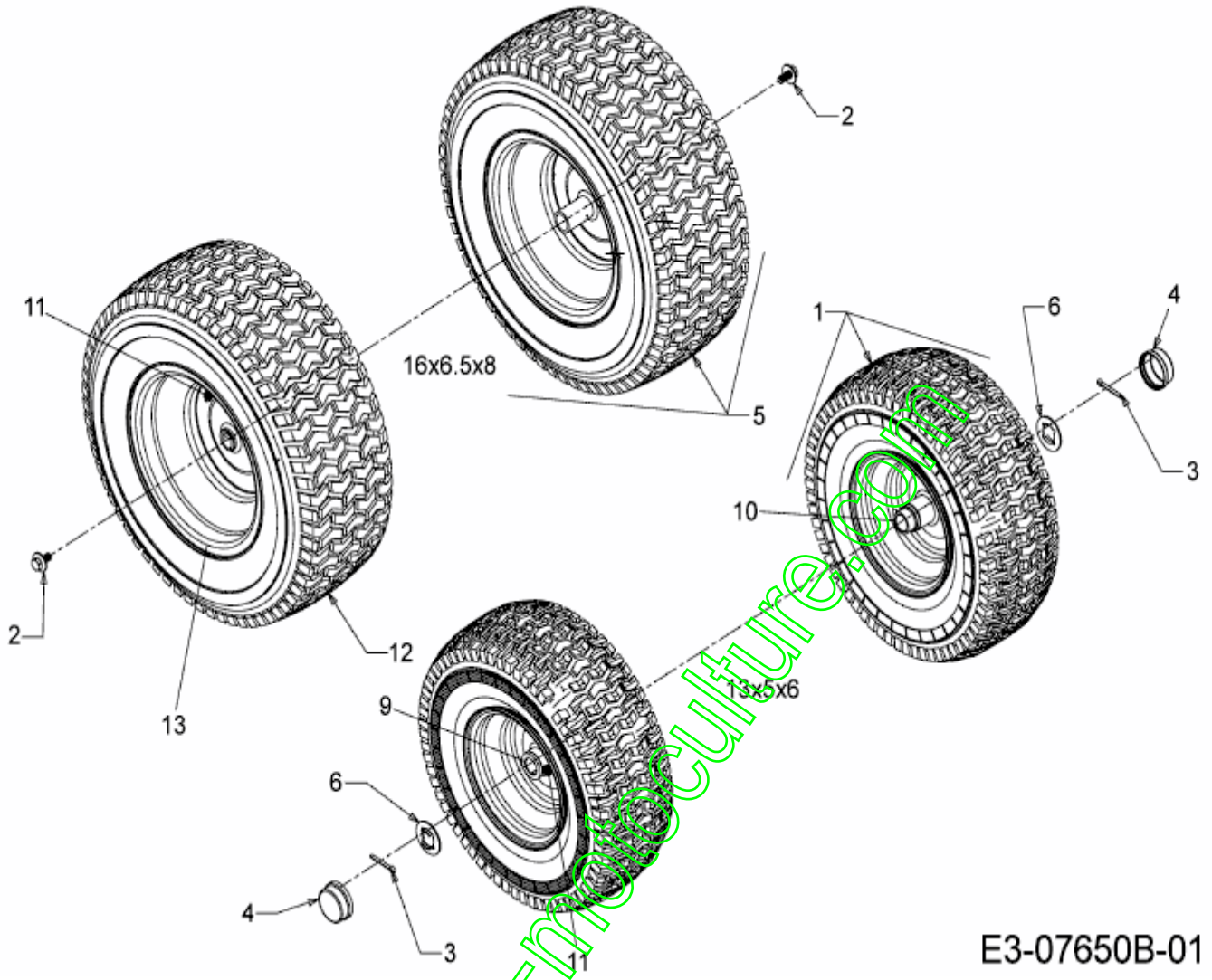

E3-07650B-01

Position	Numéro de pièce	#	Appellation I	Appellation II
1	634-04726	2	634-04726	634-04726
2	710-05339	2	VIS	GR5 E-TEIL-SET
3	714-0162	2	GOUPILLE FENDUE 5/32:1.25	FINISH:MTD SPEC-100015
4	731-0484A	2	ENJOLIVEUR DEVANT	KUNSTSTOFF SCHWARZ 931-0484A
5	734-0591	2	ROUE COMPL 16XXX6,50- 8 ST	734-0591-0912
6	736-04228A	2	RONDELLE	FINISH:MTD SPEC 701- 01000
7	734-04640	2	PNEU 13 X 5.0 X 6	FINISH:
9	741-0516B	2	BAGUE DE ROUE .760x1.00x1.20	FINISH: SCHWARZ
10	741-0990B	2	BAGUE DE ROUE AVEC GRAISSEUR	m. SCHMIERNIPPEL: FINISH SCHWARZ
11	734-0255	4	VALVE: PNEU	TR 412-P / 32.6mm / 934- 0255
12	734-04641	2	PNEU 16.00X6.50X8.00	FINISH:
13	634-04174	2	JANTE 8.0x5.38 AVEC VALVE	

www.emc-motoculture.com

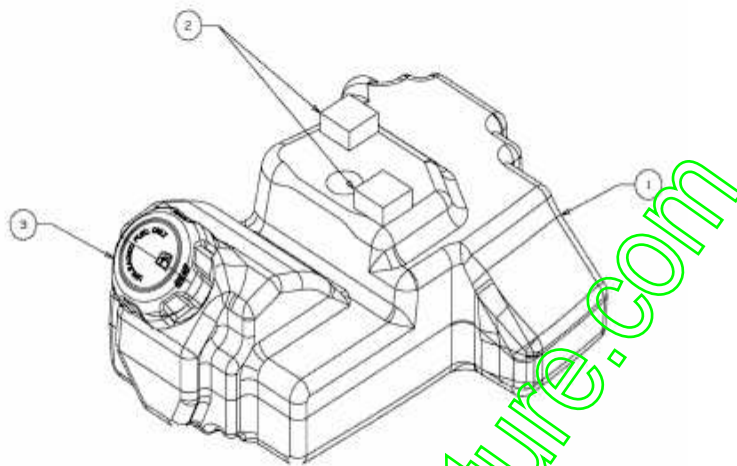

E3-07651B-01

Position	Numéro de lapièce	#	Appellation I	Appellation II
1	651-04385B	1	RESERVOIR	651-04385B
2	722-3020	2	KANTENSCHUTZ	722-3020
3	751-12179B	1	BOUCHON DE RESERVOIR ESSENCE	FINISH:SIEHE ZG.

www.emc-motoculture.com

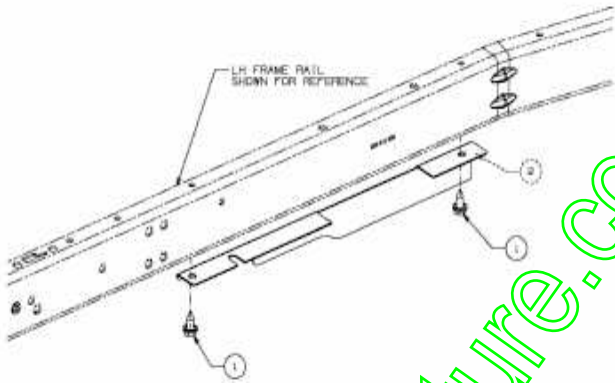

www.emc-motoculture.com

E3-07654B-01

Position	Numéro de lapièce	#	Appellation I	Appellation II
1	710-1652	2	VIS HEX. TT:1/4- 20:.625:HXINDW	FINISH:MTD-SPEC-701- 01002
2	783-08208	1		

www.emc-motoculture.com

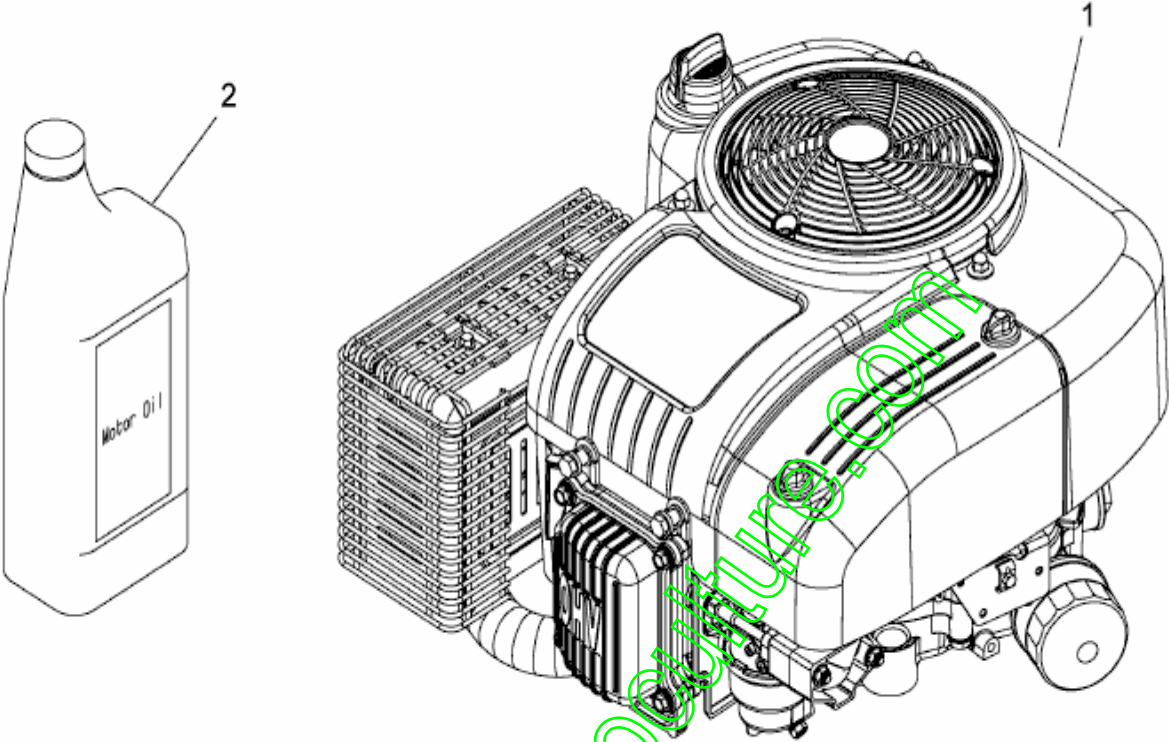

E3-08294D-01

Position	Numéro de pièce	#	Appellation I	Appellation II
1	752Z4P90JHD	1	MOTEUR COMPLET	752Z4P90JHD
2	6012-X1-0033	X	HUILE MULTIGRADE	6012-X1-0033

www.emc-motoculture.com

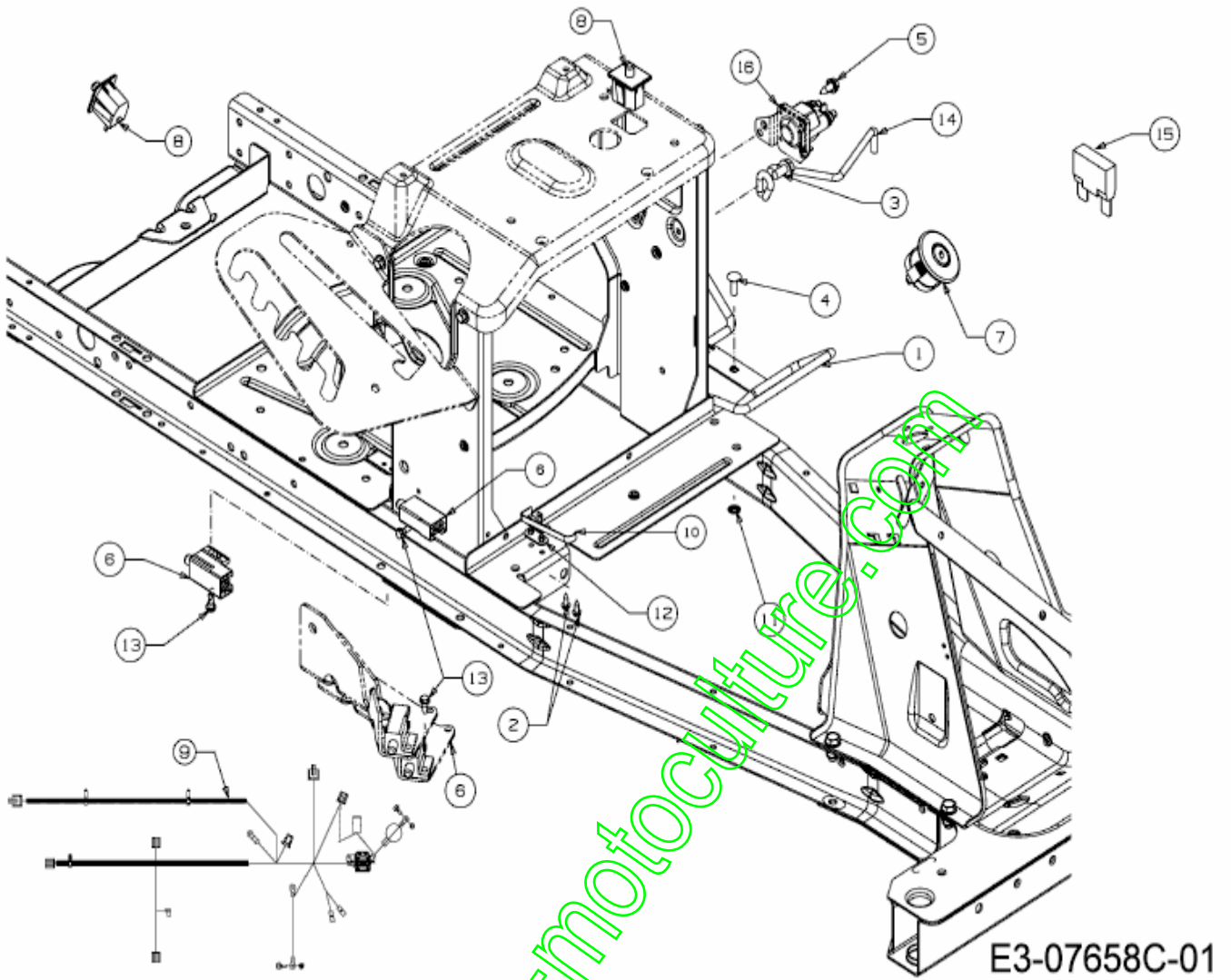

www.emc-motoculture.com

Position	Numéro de lapièce	#	Appellation I	Appellation II
1	683-05056A	1	TRINGLE SUPPORT BATTERIE	683-05056A
2	710-0227	2	VIS	FINISH:MTD STD 701- 01002
3	710-04484	1	VIS HEX. TT:5/16- 18:.750:HXIND	FINISH:MTD SPEC-701- 01002
4	710-0703	1	VIS	FINISH:MTD STD 701- 01000
5	710-1652	1	VIS HEX. TT:1/4- 20:.625:HXINDW	FINISH:MTD-SPEC-701- 01002
6	725-04363	3	SECURITE	FINISH:SIEHE ZG.
7	725-04659	1	CONTACTEUR A CLEF	FINISH:
8	725-05013	2	SECURITE DE SIEGE	FINISH:GRAU
9	725-06275	1	FAICSEAU ELECTRIQUE	725-06275
10	725-1643	1	CONTACTEUR SECURITE	LANG:FINISH:SPEC- 100016
11	726-0233	1	RONDELLE	FINISH:PHOS AND OIL
12	726-0320	1	PLAQUE D'ISOLATION	FINISH:NATUR ODER SCHWARZ
13	738-04237A	3	AXE EPAULE	FINISH:MTD STD 701- 01002
14	747-06148	1	TRINGLE SUPPORT BATTERIE SUP	747-06148
15	725-04009	1	FUSIBLE 15A	725-04009
16	725-04439A	1	SOLENOIDE	12V:100 AMP

www.emc-hotculture.com

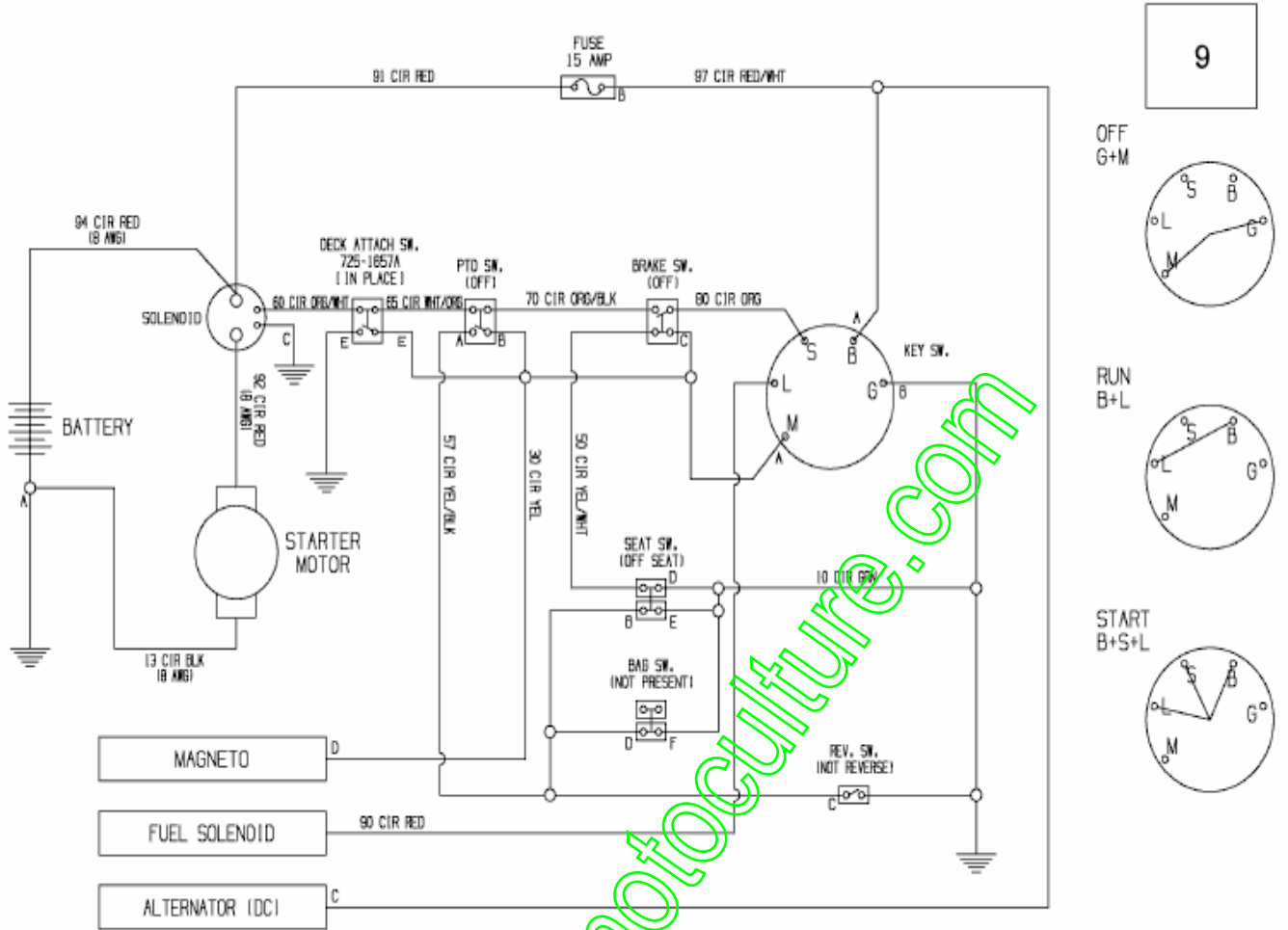

9

OFF
G+M

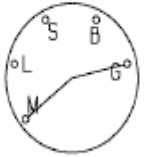

RUN
B+L



START
B+S+L



E3-07658C-02

www.emc-motoculture.com

Position	Numéro de pièce	#	Appellation I	Appellation II
9	725-06275	1	FAICSEAU ELECTRIQUE	725-06275

www.emc-motoculture.com

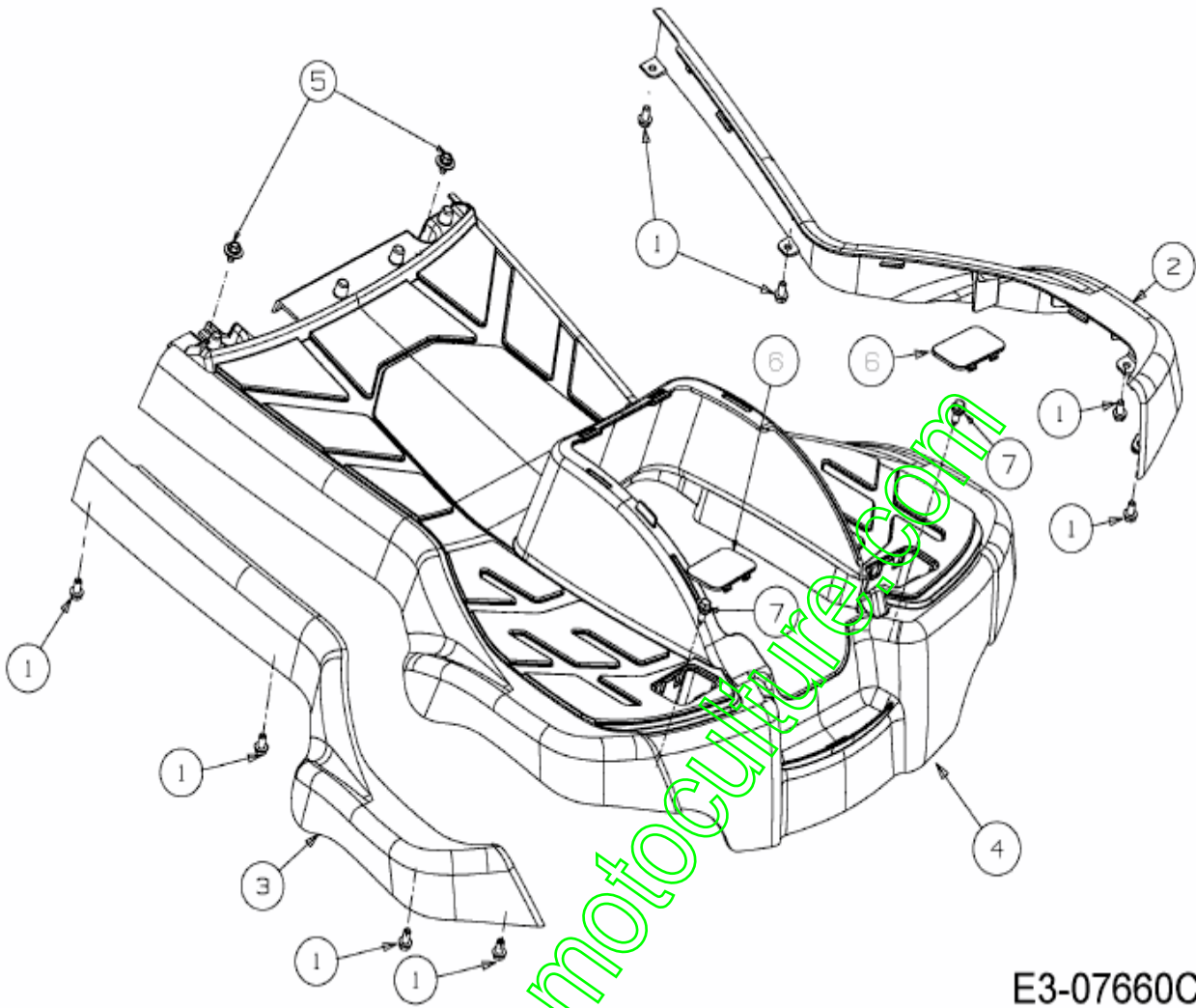

E3-07660C-01

Position	Numéro de lapièce	#	Appellation I	Appellation II
1	710-04187	8	VIS HEX.:1/4- 15:0.50:HXINDWSH	FINISH:701-01002 910- 04187
2	731-08884A	1	PROTECTION GAUCHE	731-08884A
3	731-08885A	1	PROTECTION DROITE	731-08885A
4	731-11110	1	PLATE FORME	731-11110
5	710-05073	2	VIS 1/4-20X.50	710-05073
6	731-08753A	2	BOUCHON A CLIPS	731-08753A
7	738-04184A	2	VIS i ÜPAULE:.368x.113:TT:1/4-	:1/4-20 / FINISH:701- 01002

www.emc-motoculture.com

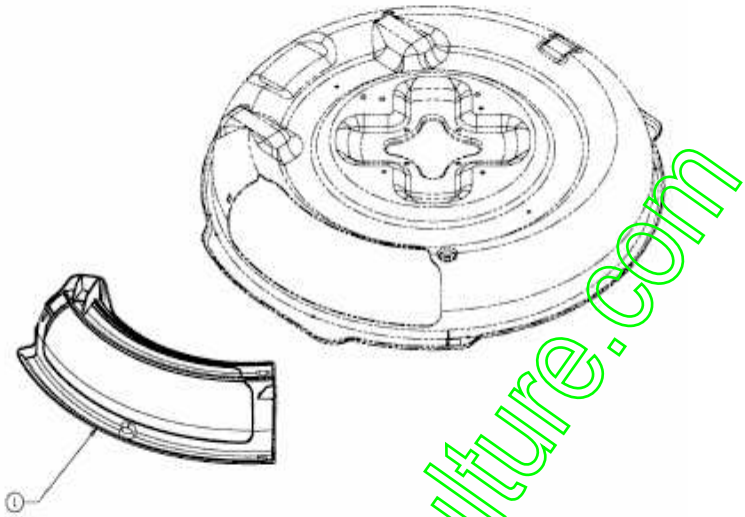

E3-08206A-01

www.emc-motoculture.com

Position	Numéro de pièce	#	Appellation I	Appellation II
1	731-09312	1	BOUCHON MULCHING	731-09312

www.emc-motoculture.com

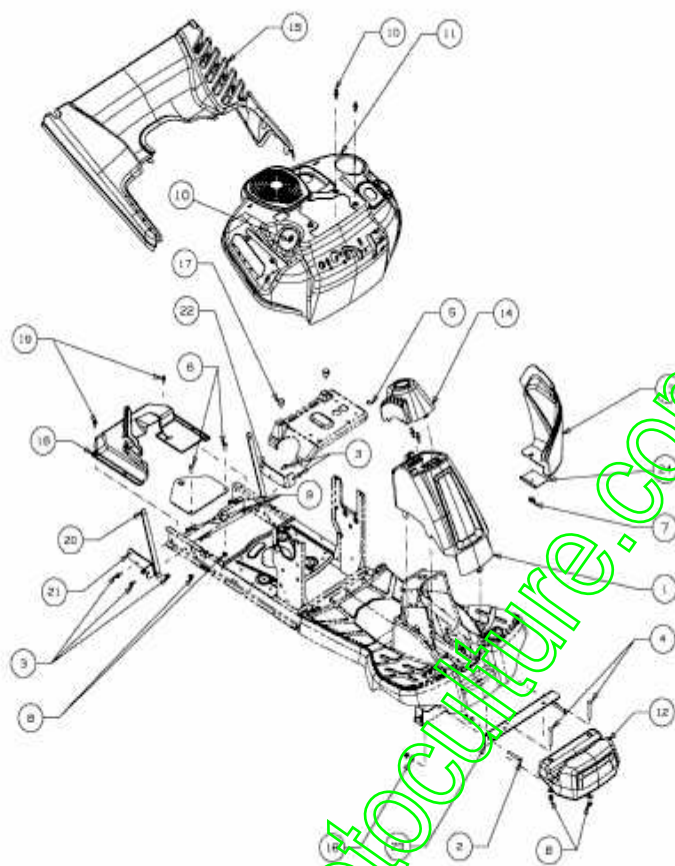

E3-08230B-01

www.emc-motoculture.com

Position	Numéro de pièce	#	Appellation I	Appellation II
1	631-05041	1	CACHE DE COLONNE INFERIEUR	631-05041
2	710-0378	2	VIS HEX.:5/16- 18:2.50:GR5:STD	FINISH:MTD SPEC 701- 01000
3	710-04666	6	VIS HEXAGONALE	FINISH:MTD SPEC-701- 010015
4	710-0572	2	VIS j T α . PL.:5/16-18:2.50:GR1	FINISH:MTD SPEC- 100015
5	710-0924	1	VIS EN T α TE PLATE 1/4- 20X;75"	FINISH:MTD STD 701- 01000
6	710-3008	2	VIS 5/16-18.:75:GR5:STD	FINISH:MTD STD 701- 01000
7	712-0397	1	ÜCROU PAPILLON	FARBE:SCHWARZ 912- 0397
8	712-04063	6	ÜCROU HEX. AVEC FLANC	FINISH:MTD STD SPEC- 101616
9	712-04064	6	ÜCROU HEXAGONAL	GRF:FINISH:701-01000 912-04064
10	728-0199	6	RIVET PLASTIQUE	PLASTIK SCHWARZ
11	731-08875A	1	CARTER DE COMMANDE CUB CADET	731-08875A
12	731-09227	1	CONTRE POIDS	731-09227
13	731-09371	1	COUVERCLE DE BATTERIE	731-09371
14	731-09399	1	CACHE DE COLONNE SUPERIEUR	731-09399
15	731-09404	1	CARTER PASTIQUE	731-09404
16	731-10504	1	TOLE DE PROTECTION	731-10504
17	735-05006	2	TAMPON DE SIEGE	FINISH:BLACK
18	736-0159	4	RONDELLE .349 X 88X.06"	FINISH:701-01000
19	738-04184A	2	VIS ÜPAULE: .368x.113:TT:1/4-	:1/4-20 / FINISH:701- 01002
20	783-07314	2		
21	783-07319A	1	SUPPORT DROITE	783-07319A
22	783-07376A	1	SUPPORT GAUCHE	783-07376A
23	783-08135	1		
24	783-08277	1		

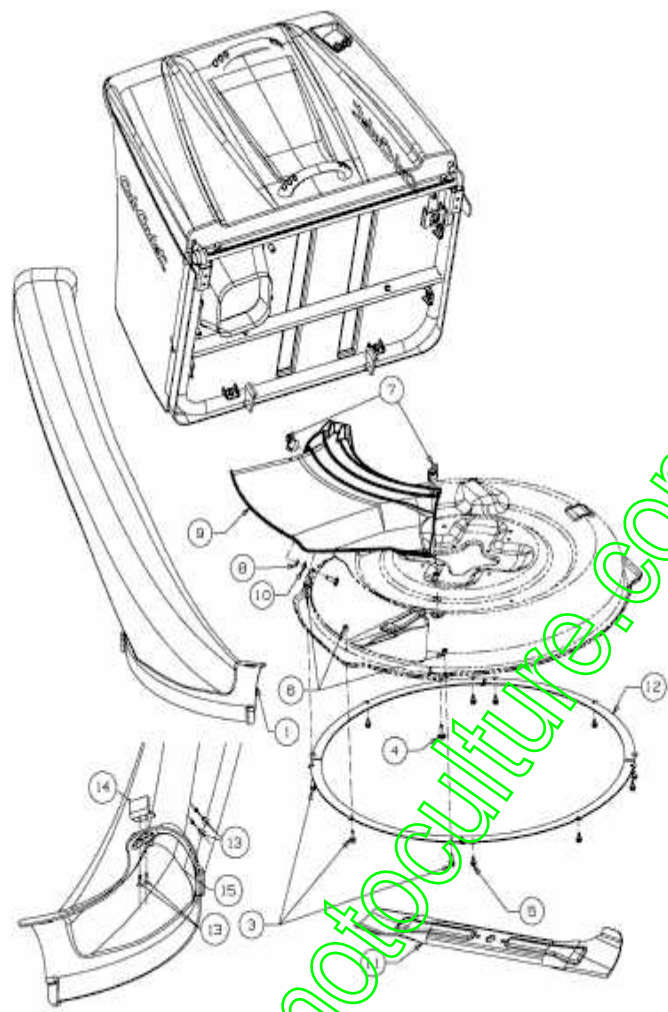

E3-08231C-01

www.emc-motoculture.com

Position	Numéro de pièce	#	Appellation I	Appellation II
1	731-09349	1	GOULOTTE	FINISH:KUNSTSTOFF SCHWARZ
3	710-04666	3	VIS HEXAGONALE	FINISH:MTD SPEC-701-010015
4	710-04998	2	VIS j TATE PLATE	FINISH:MTD STD 701-01000
5	710-1652	9	VIS HEX. TT:1/4- 20:.625:HXINDW	FINISH:MTD-SPEC-701-01002
6	712-04351	3	ECROU	FINISH:MTD STD SPEC 101616
7	720-04122	2	ECROU PAPILLON	FINISH: SIEHE ZG.
8	726-0201	2	RONDELLE .3125 ID	FINISH:SPEC-101617
9	731-10267	1	DEFLECTEUR	PIKTOGRAMME:KUNSTSTOFF SCHWARZ
10	736-0242	2	RONDELLE CONIQUE.340X.872X.060	FINISH:MTD STD 701-01001
11	742-05116	1	LAME SOUFFLANTE 76 CM	FINISH: SIEHE ZG.
12	783-08572	4		
13	728-0123	4	RIVET 188 X 402 "	FINISH:VERZINKT SIEHE ZG
14	783- 07286A-S	1	SUPPORT DE SECURITE	783-07286A-S
15	783- 07398637	1	DEFLECTEUR	783-07398637

www.emc-motoculture.com

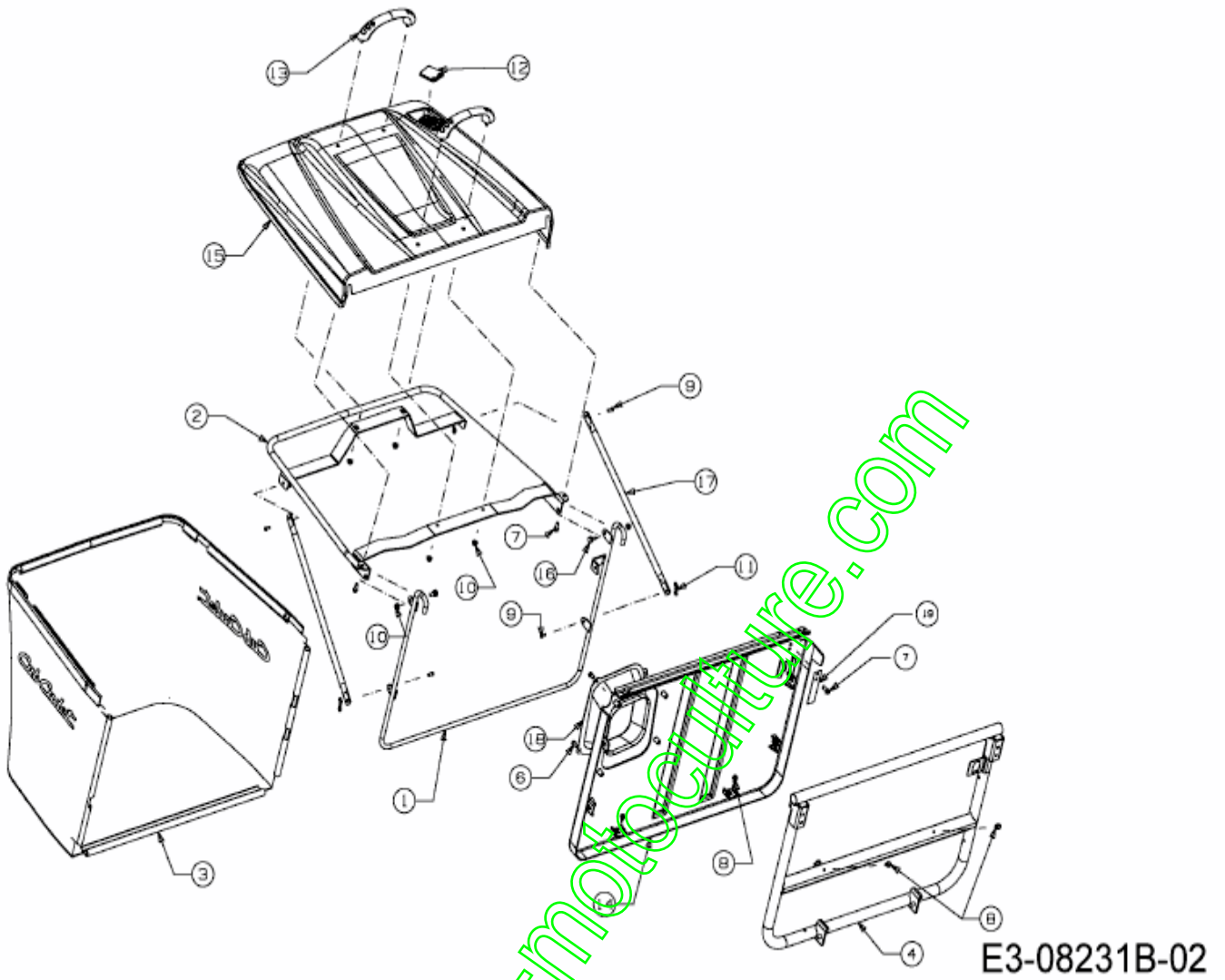

Position	Numéro de lapièce	#	Appellation I	Appellation II
1	647-05019	1		
2	649-05005	1		
3	664-05023	1	TOILE DE BAC CUB CADET	FINISH:
4	683-05051A	1		
6	710-04187	4	VIS HEX.:1/4- 15:0.50:HXINDWSH	FINISH:701-01002 910- 04187
7	710-0895	3	VIS j SIX PANS CREUX	FINISH:MTD STD 701-01002
8	710-1652	8	VIS HEX. TT:1/4- 20:.625:HXINDW	FINISH:MTD-SPEC-701- 01002
9	711-0701	4	GOUJON	FINISH: SIEHE ZG.
10	712-04064	6	ÜCROU HEXAGONAL	GR: FINISH:701-01000 912- 04064
11	714-04040	4	GOUPILLE	FINISH:VERZINKT
12	731-05257A	1	IND. DE NIVEAU: SAC D'HERBE	FINISH: SCHWARZ
13	731-09308	2	POIGNEE DE BAC	CR12:KUNSTSTOFF SCHWARZ
14	731-09354	1	PLAQUE ARRIERE	KUNSTSTOFF SCHWARZ
15	731-09430	1	PLAQUE ARRIERE	731-09430
16	738-04419A'0	2		
17	749-05056	2		
18	764-04152A	1	SUPPORT DE GOULOTTE	FINISH:
19	783-08218	1	LANGUETTE DE SECURITE	FINISH:701-01006

www.emc-inoculture.com

Position	Numéro de lapièce	#	Appellation I	Appellation II
1	16606	2	ÜTRIER D'ACCROCHAGE	FINISH:BLAU CHROMATIERT *
2	710-04187	1	VIS HEX.:1/4- 15:0.50:HXINDWSH	FINISH:701-01002 910- 04187
3	710-05204	1	VIS	FINISH:MTD SPEC- 101617
4	710-0895	2	VIS j SIX PANS CREUX	FINISH:MTD STD 701- 01002
5	714-04040	2	GOUPILLE	FINISH:VERZINKT
7	783-07299	1		

www.emc-motoculture.com

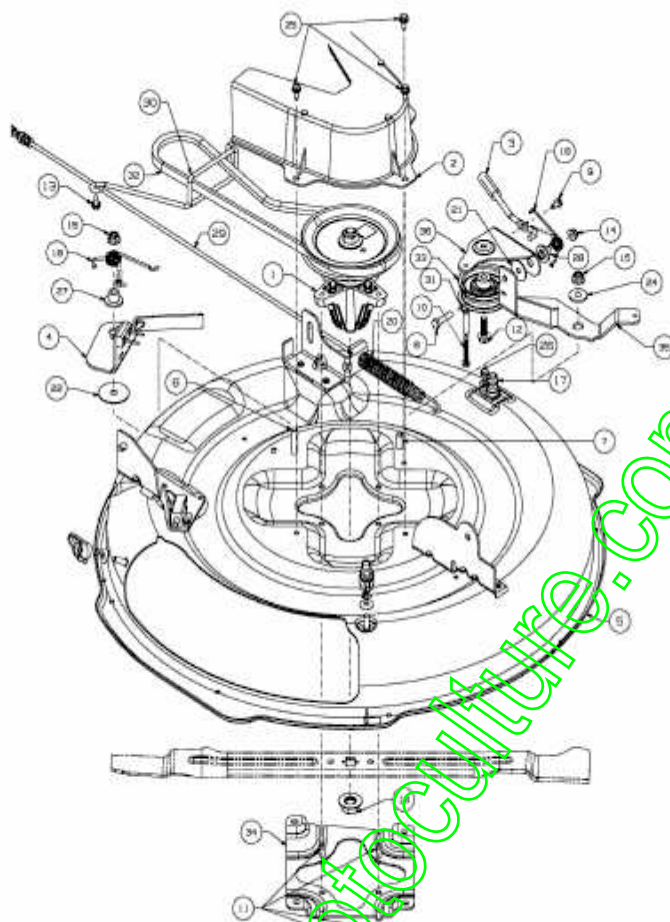

E3-08227C-01

Position	Numéro de pièce	#	Appellation I	Appellation II
1	618-04822B	1	PALIER DE LAME COMPLET	Ø 6.3":FINISH 918-04822B
2	631-05024	1	CARTER PROTECTION DE COURROIE	631-05024
3	647-05028	1	LEVIER	647-05028
4	683-05034	1	FREIN DE LAME	UND NIETEN
5	683-05039A-S	1	CARTER DE COUPE 76 CM	683-05039A-S
6	710-0347	1	VIS HEX. 3/8-16:1.75:GR5:STD	FINISH:MTD STD 701-01000
7	710-0514	1	VIS HEX.:3/8-16:1.00:GR5:STD	FINISH:MTD STD 701-01000
8	710-0528	1	VIS HEX. 5/16-18:1.25:GR5:STD	FINISH:STD 701-01000 910-0528
9	710-0599	1	VIS i SIX PANS CREUX	MTD SPEC-701-01002 or 101617
10	710-1026	1	VIS HEX:TT:1/4-20:1.750	FINISH:MTD-SPEC-100016
11	710-1260A	4	VIS TT:5/16-18:.750 HXINDWSH	LAGERGEH.MESSERWELLE:701-01002
12	710-1315	1	VIS HEX.TT:3/8-16:1.25:HXIN:S	FINISH:MTD SPEC-701-01002
13	710-1652	1	VIS HEX. TT:1/4-20:.625:HXINDW	FINISH:MTD-SPEC-701-01002
14	712-04063	1	ÜCROU HEX AVEC FLANC	FINISH:MTD STD SPEC-101616
15	712-04065	2	ÜCROU HEXAGONAL	FINISH:SPEC-101616 912-04065
16	712-0417A	1	ÜCROU HEX. AV. FLANC: 5/8-18	FINISH:MTD STD 701-01000
17	731-07487	1	BUSE DE NETTOYAGE PLATEAU	FINISH:SCHWARZ 788-0637
18	732-05045	1	RESSORT	FINISH:SPEC-100015
19	732-05046	1	RESSORT	FINISH:SPEC-701-01006
20	732-0583	1	RESSORT	FINISH:PHOS & OIL
21	736-0362	1	RONDELLE .320ID X 1.25 ODX .0	FINISH:701-01001
22	736-3040	1	RONDELLE	FINISH:MTD STD 701-01000
24	738-0347	1	RONDELLE i EMB. .625IDx.169	FINISH:
25	738-04184A	3	VIS i ÜPAULE:.368x.113:TT:1/4-	:1/4-20 / FINISH:701-01002
26	738-04278	1	VIS	FINISH:MTD STD SPEC-100015
27	738-05021	1	ENTRETOISE	738-05021

Position	Numéro de pièce	#	Appellation I	Appellation II
28	738-05022	1	ENTRETOISE	738-05022
29	746-04802A	1	CABLE PTO	FINISH: SIEHE ZG.
30	747-06126A	1	GUIDE COURROIE	747-06126A
31	750-04456	1	ENTRETOISE	FINISH:VERZINKT SIEHE ZG.
32	754-05001	1	COURROIE DE LAME MINIRIDER	FINISH: N/A
33	756-04224	1	POULIE TENDEUR	FINISH:SIEHE ZG.
34	783-08047A	1	RENFORT CARTER DE COUPE	783-08047A
35	783-08128	1	SUPPORT	783-08128
36	783-08226A-S	1	SUPPORT POULIE TENDEUR	783-08226A-S

www.emc-motoculture.com

Position	Numéro de pièce	#	Appellation I	Appellation II
1	710-04483	2	VIS:TT:1/4-20:.500:TRUSTRXI	FINISH:GELB SPEC-701-01002
2	710-04683C	3	VIS	FINISH:SIEHE ZG.
3	710-05446	1	VIS	FINISH:MTD SPEC-701-01002
4	710-06067	1	VIS	FINISH:MTD STD 701-01000
5	712-04242	1	ECROU	FINISH:MTD SPEC-100015
6	712-0691	1	ÜCROU HEXAGONAL	MTD SPEC-100015 24.1426.14
7	726-0205	2	COLLIER DE SERRAGE DE BOYAU	FINISH:PHOSPHATIERT (GELB)
8	731-1682A	1	DRAINAGE HUILE	FINISH:KUNSTSTOFF SCHWARZ
9	736-0322	1	RONDELLE .450 X 1.250 X .164	FINISH:701-01001 936-0322
10	6012-X1-0033	X	HUILE MULTRIGRADE	6012-X1-0033
11	746-05049	1	CABLE GAZ	MIT BEDIENUNGSHEBEL
12	746-1088	1	CABLE STARTER 23.0"LGX1.50E	EXT:MIT ZUGKNOPF
13	751-10349	1	TUYAU ESSENCE	MIN:1/4:FINISH SCHWARZ
14	751-3013	1	FILTRE ESSENCE	COLOR:RED 951-3013
15	756-04479A	1	POULIE MOTEUR	Ø4.46"/Ø3.39":SPEC-100015
16	783-08843	1	KONSOLE:DREHZAHLBEGRENZUNG	FINISH:GELB VERZINKT 701-01000

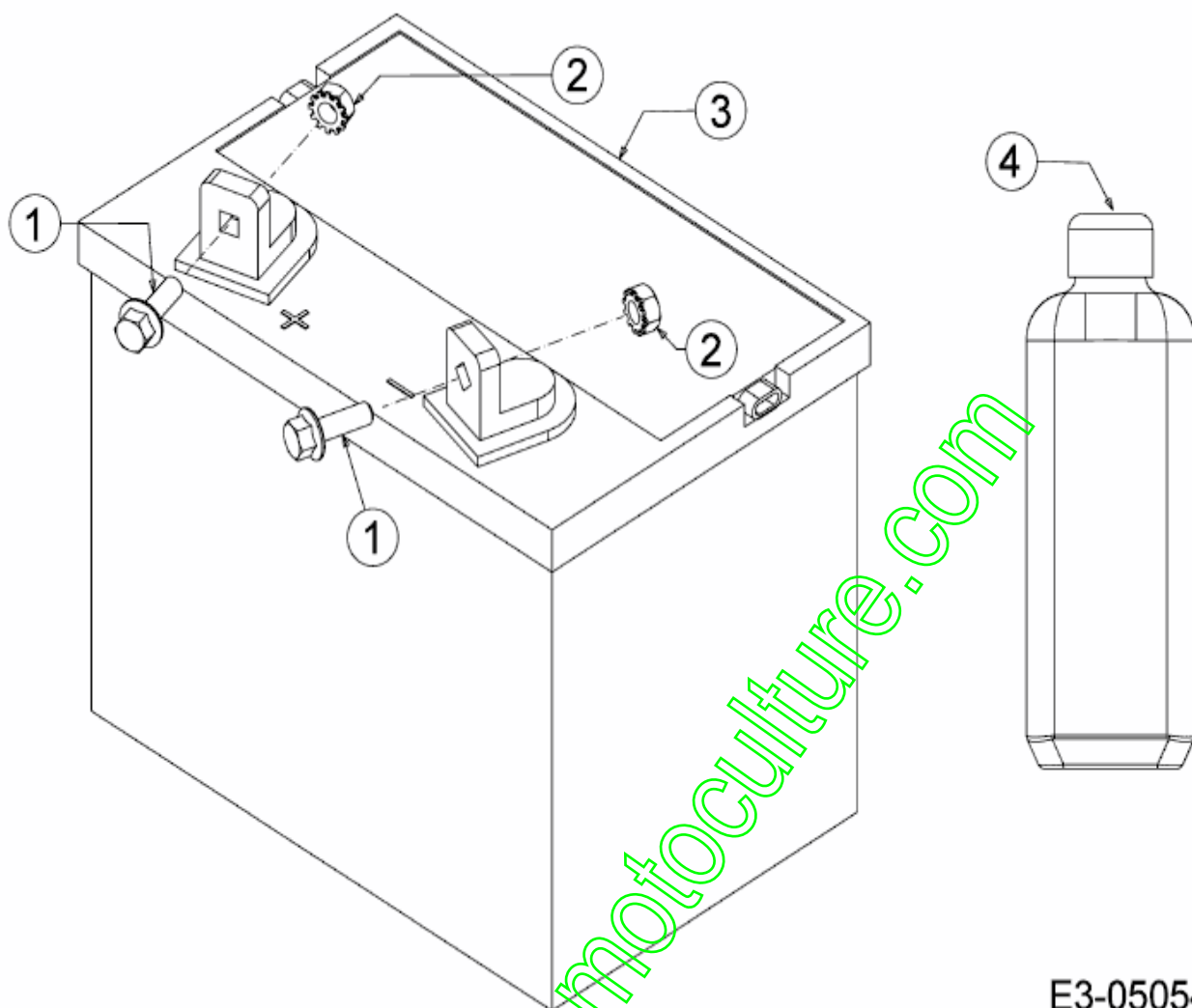

E3-05054A-01

Position	Numéro de lapièce	#	Appellation I	Appellation II
1	710-04666	2	VIS HEXAGONALE	FINISH:MTD SPEC-701-010015
2	712-0271	2	ECROU 1/4-20"+ DISQUE DENTÜ	FINISH:MTD STD 701-010015
3	725-1704A	1	BATTERIE:U1: 150 CCA WET	FINISH:
4	725-2064	2	BIDON ACIDE 1 LITRE	725-2064

www.emc-motoculture.com

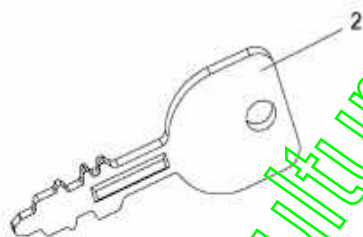
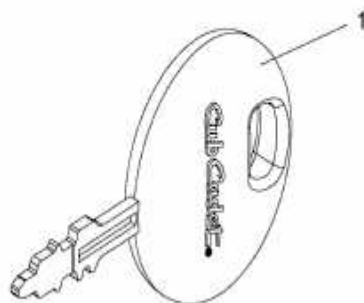

www.emc-motoculture.com

E3-08234A-01

Position	Numéro de pièce	#	Appellation I	Appellation II
1	725-2054A	1	CLÜ DE CONTACT JAUNE	CUB CADET
2	725-1744A	1	CLE DE CONTACT	FINISH:

www.emc-motoculture.com

www.emc-motoculture.com