

Jonsered

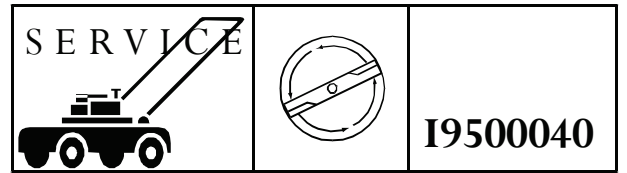

IPL, GRASS COLLECTOR, LR10, LR12, LR13, LT14, YTH16, 1995-01

CE36, CE36B CE38C, CE42C CW342A

Spare parts

Ersatzteile

Pièces détachées

Reserve onderdelen

Repuestos

Reservdelar

www.emc-motoculture.com

REPAIR PARTS

GRASS CATCHER - MODEL NUMBER CE36, CE36B

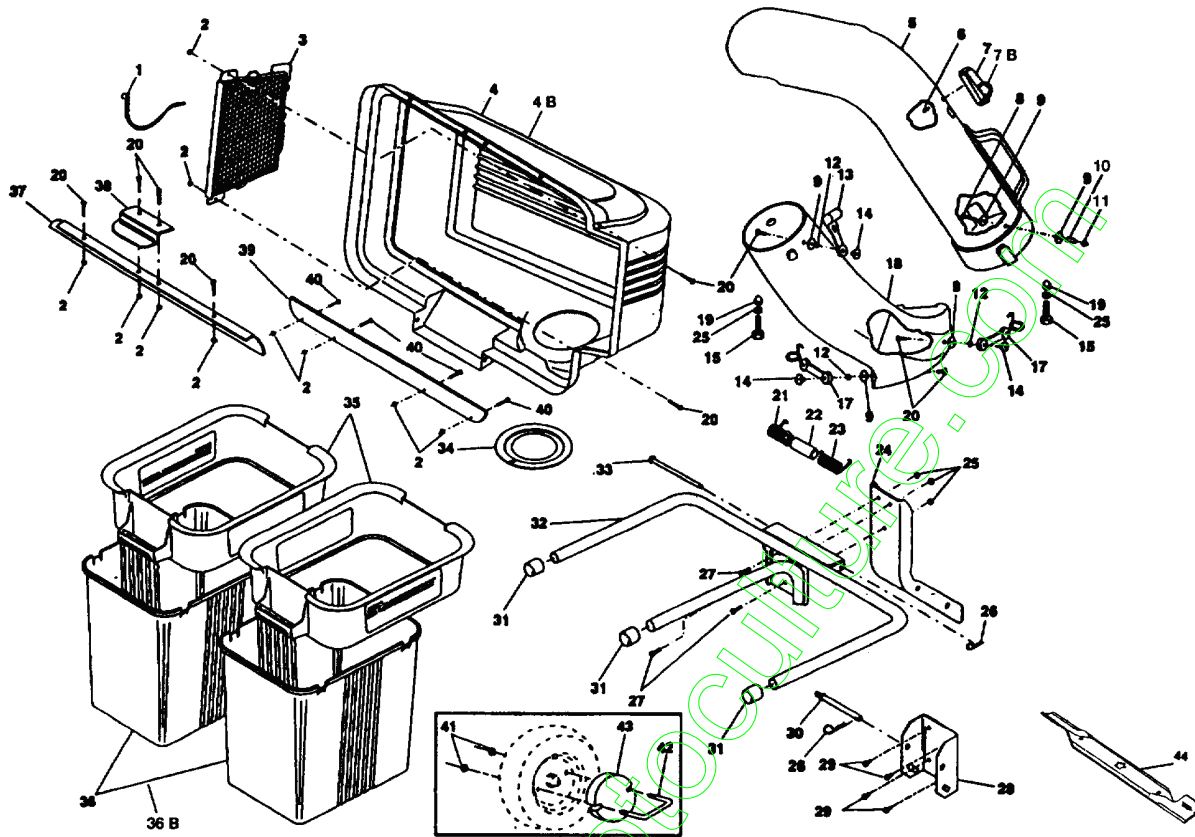

KEY PART NO.	NO.	DESCRIPTION	KEY PART NO.	NO.	DESCRIPTION
1	532 12 47-56	Tie, Cable CE36B	24	532 12 77-20	Post, Support
2	532 06 91-80	Locknut #10-24	25	532 06 31-24	Locknut 5/16 x 18
3	532 12 75-33	Screen, Cover	26	532 08 59-02	Spring, Retainer
4	532 12 68-16	Cover CE36B	27	874 78 05-12	Bolt, Hex 5/16-18
4B	532 14 06-54	Cover CE36	28	532 13 08-89	Bracket, Mounting
5	532 12 85-98	Chute, Upper	29	817 49 05-08	Screw, Thread Rolling 5/16-18 x 1/2
6	818 02 10-08	Screw, Special	30	532 13 11-37	Pin, Support Post
7	532 13 09-33	Indicator, Bagger Full CE36B	31	532 13 44-96	Cap, Tubing End
7B	532 14 05-72	Indicator, Bagger Full CE36	32	532 12 69-19	Bagger, Frame
8	874 98 10-20	Screw, #10-24 x 1-1/8	33	532 12 86-00	Pin, Hinge
9	819 06 12-16	Washer 3/16 x 3/4 x 16 Ga.	34	532 12 75-34	Gasket, Cover
10	532 00 72-06	Spacer, Split	35	532 12 95-85	Container, Top
11	532 06 08-67	Nut, Acron #10-24	36	532 12 95-86	Container, Bottom CE36B
12	810 07 10-00	Washer, Lock	36B	532 13 24-31	Container, Bottom CE36
13	532 10 98-08	Latch, Chute	37	532 13 22-56	Seal, Cover
14	532 00 20-29	Nut, Weld	38	532 13 08-95	Latch Handle, Cover
15	874 78 05-16	Bolt, Hex 5/16-18 x 1	39	532 13 54-95	Strip, Seal
17	532 13 07-58	Latch Assy., Bagger	40	532 04 19-45	Screw #10-24 x 1/2
18	532 12 85-99	Chute, Lower	41	873 68 06-00	Locknut 3/8-16
19	532 13 38-41	Nut, Acorn 5/16-18	42	532 13 70-31	U-Bolt
20	532 04 19-45	Screw #10-24 x 1/2	43	532 12 36-35	Weight, Wheel
21	532 13 27-96	Spring, Cover L.H. (black)	44	532 13 84-96	Blade, High Lift
22	532 13 32-35	Spacer, Cover	--	532 10 50-70	Bag, 3.0 mil. 30 Gallon Trash (not included with bagger)
23	532 13 29-83	Spring, Cover R.H. (gray)			

REPAIR PARTS

GRASS CATCHER - MODEL NUMBER CE38C

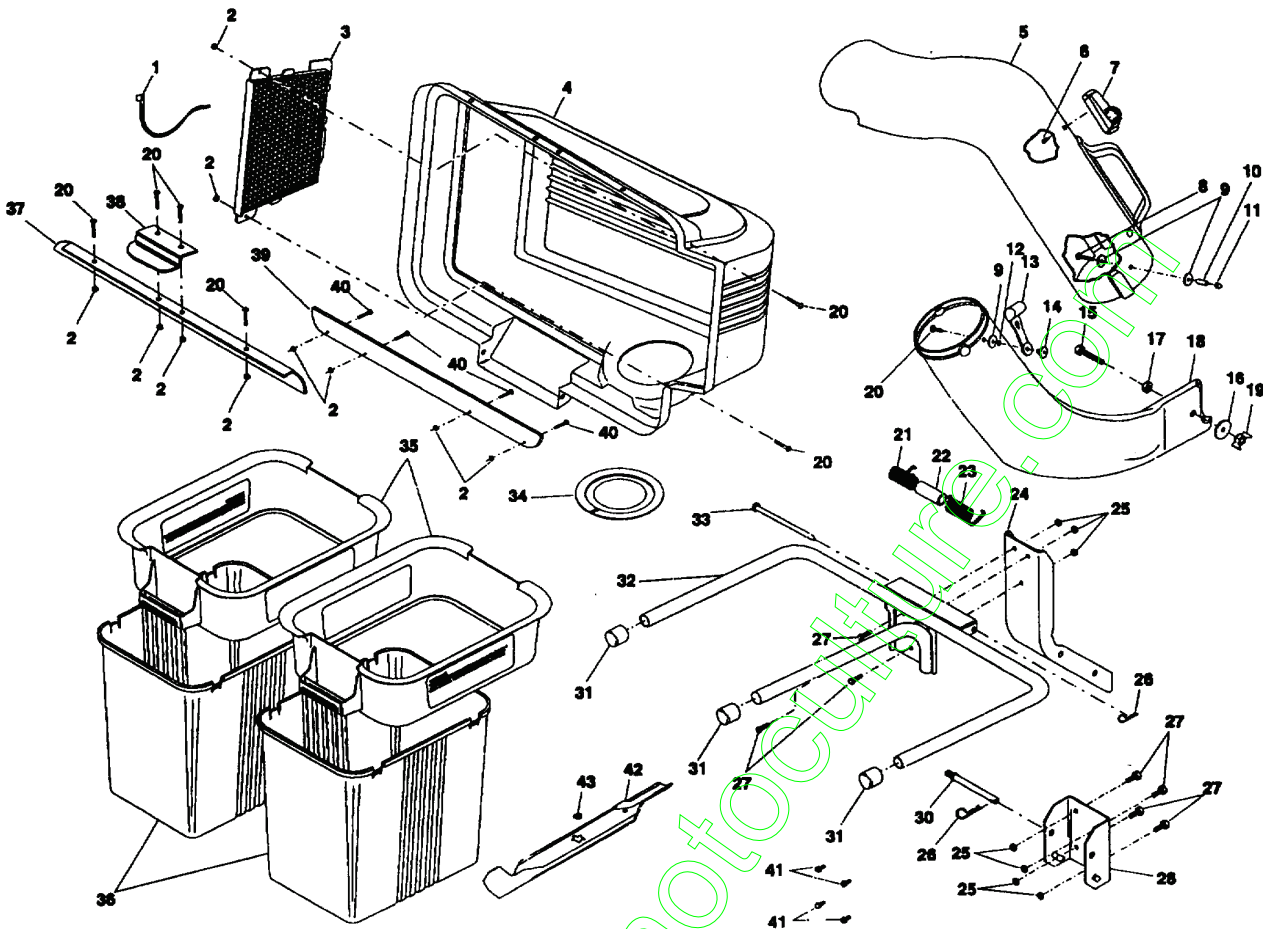

KEY PART NO. NO.

DESCRIPTION

1	532 12 47-56	Tie Cable
2	532 06 91-80	Locknut#10-24
3	532 12 75-33	Screen, Cover
4	532 12 68-16	Cover
5	532 13 24-79	Chute, Upper
6	818 02 10-08	Screw, Special #10-14 x 1/2
7	532 13 09-33	Full Bagger Indicator
8	874 98 10-20	Screw, #10-24 x 1-1/8
9	819 06 12-16	Washer 3/16x3/4x 16Ga.
10	532 00 72-06	Spacer, Split
11	532 06 08-67	Nut, Acron #10-24
12	810 07 10-00	Washer, Lock
13	532 10 98-08	Latch, Chute
14	532 00 20-29	Nut, Weld
15	874 93 06-20	Bolt, Hex 3/8-16 x 1-1/4
16	819 13 16-16	Washer 1332 x 1 x 16 Ga.
17	873 68 06-00	Locknut 3/8-16
18	532 13 29-72	Chute, Lower
19	532 13 11-30	Wingnut 3/8-16
20	532 04 19-45	Screw #10-24 x 1/2

KEY PART NO. NO.

DESCRIPTION

21	532 13 27-96	Spring, Cover L.H. (black)
22	532 13 32-35	Spacer, frver
23	532 13 29-83	Spring, Cover, R.H (gray)
24	532 12 68-13	Post, Support
25	873 68 05-00	Locknut 5/16 x 18
26	532 08 59-02	Spring, Retainer
27	874 78 05-12	Bolt, Hex 5/16x18
28	532 13 08-89	Bracket, Mounting
30	532 13 11-37	Pin, Support Post
31	532 13 44-96	Cap, Tubing End
32	532 12 69-19	Bagger, Frame
33	532 12 86-00	Pin, Hinge
34	532 12 75-34	Gasket, Cover
35	532 12 95-85	Container, Top
36	532 12 95-86	Container, Bottom
37	532 13 22-56	Seal, Cover
38	532 13 08-95	Latch Handle, Cover
--	532 10 50-70	Bag, 3.0 mil. 30 Gallon Trash (not included with bagger)
39	532 13 54-95	Strip Seal
40	532 04 19-45	Screw 10-24 x 1/2
41	817 49 05-08	Screw 5/16-18 x 1/2
42	532 13 84-97	Blade, High Lift
43	532 13 82-00	Washer

REPAIR PARTS

GRASS CATCHER - MODEL NUMBER CE42C

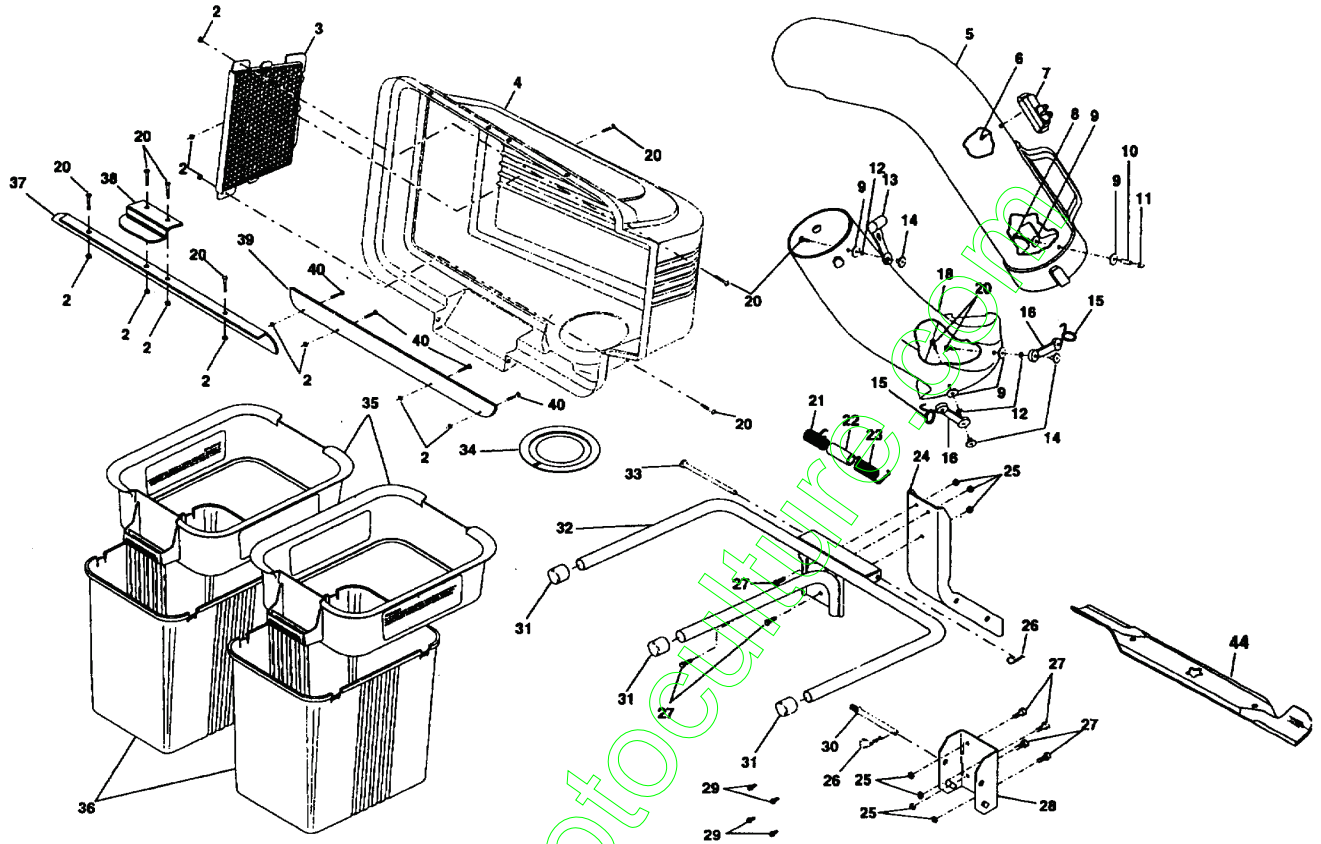

KEY PART NO. NO.

DESCRIPTION

2	532 06 91-80	Locknut#10-24
3	532 12 75-33	Screen, Cover
4	532 14 06-54	Cover
5	532 12 68-40	Chute, Upper
6	818 02 10-08	Screw, Special #10-14 x 1/2
7	532 14 05-72	Full Bagger Indicator
8	874 98 10-20	Screw, #10-24 x 1-1/8
9	819 06 12-16	Washer 3/16 x 3/4 x 16 Ga.
10	532 00 72-06	Spacer, Split
11	532 06 08-67	Nut, Acorn#10-24
12	810 07 10-00	Washer, Lock
13	532 10 98-08	Latch, Chute
14	532 00 20-29	Nut, Weld
15	532 13 07-60	Latch, Hook
16	532 13 07-59	Rubber, Latch
18	532 12 68-39	Chute, Lower
20	532 04 19-45	Screw #10-24 x 5/8
21	532 13 27-96	Spring, Cover L.H. (black)

KEY PART NO. NO.

DESCRIPTION

22	532 13 32-35	Spacer, Cover
23	532 13 29-83	Spring, Cover R.H. (gray)
24	532 12 68-13	Post, Support
25	532 06 31-24	Locknut 5/16 x 18
26	532 08 59-02	Spring, Retainer
27	874 78 05-12	Bolt, Hex 5/16-18 x 3/4
28	532 13 08-89	Bracket, Mounding
29	817 49 05-08	Screw 5/16-18 x 1/2
30	532 13 11-37	Pin, Support Post
31	532 13 44-96	Cap, Tubing End
32	532 12 69-19	Bagger, Frame
33	532 12 86-00	Pin, Hinge
34	532 12 75-34	Gasket, Cover
35	532 12 95-85	Container, Top
36	532 12 95-86	Container, Bottom
37	532 13 22-56	Seal, Cover
38	532 13 08-95	Latch Handle, Cover
39	532 13 54-95	Strip, Seal
40	532 04 19-45	Screw#10-24x 1/2
--	532 10 50-70	Bag, 3.0 mil. 30 Gallon Trash (not included with bagger)
44	532 13 84-96	Blade, High Lift

REPAIR PARTS

GRASS CATCHER – MODEL NUMBER CW342A

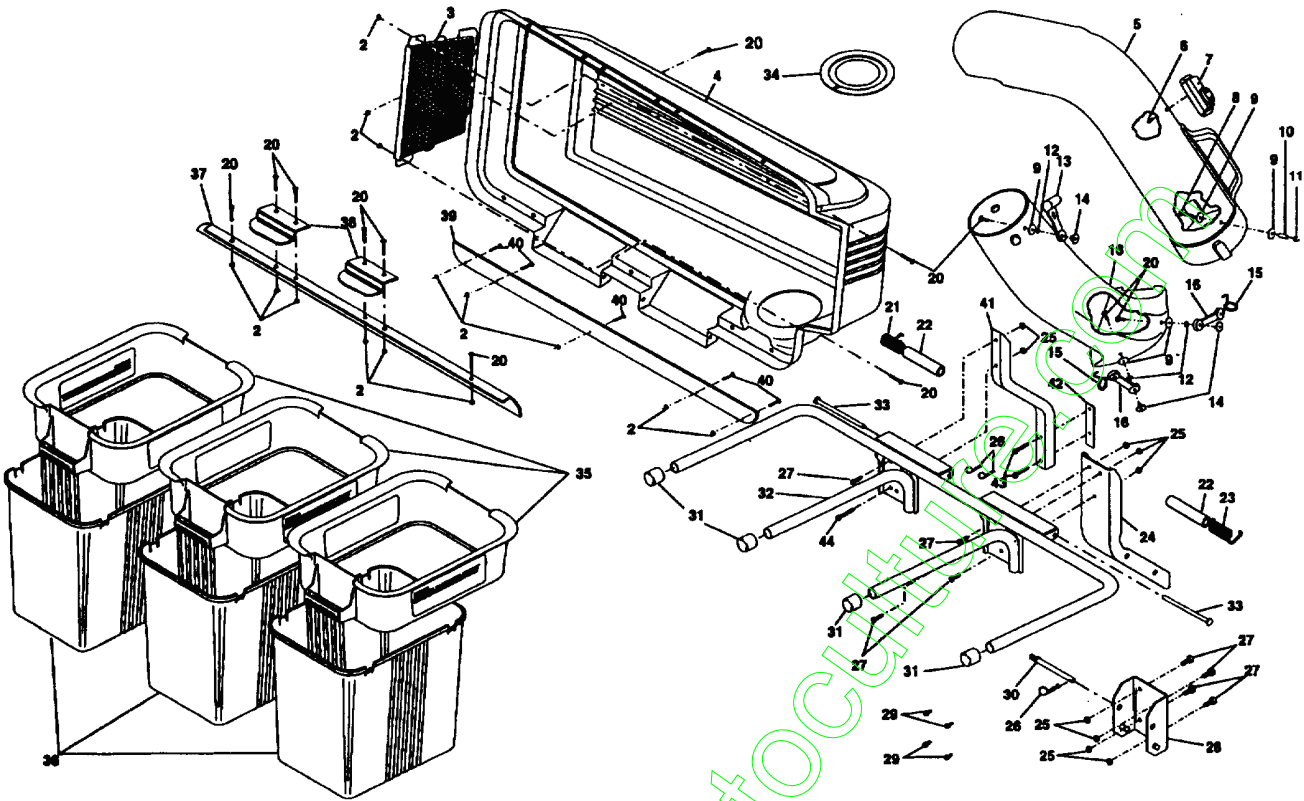

KEY PART NO.	NO.	DESCRIPTION	KEY PART NO.	NO.	DESCRIPTION
2	532 06 91-80	Nut, Crownlock#10-24	27	874 78 05-12	Bolt, Hex 5/16-18 x 3/4
3	532 12 75-33	Screen, Cover	28	532 13 08-89	Bracket, Mounting
4	532 13 46-78	Cover	29	817 49 05-08	Screw 5/16-18 x 1/2 Hex, Self Tapping
5	532 12 68-40	Chute, Upper	30	532 13 11-37	Pin, Support Post
6	818 02 10-08	Screw, Special #10-14 x 1/2	31	532 13 44-96	Plug, Tubing End
7	532 13 09-33	Fuil BaggerIndicator	32	532 13 46-39	Bagger, Frame
8	874 98 10-20	Screw, #10-24 x 1-1/8	33	532 12 86-00	Pin, Hinge
9	819 06 12-16	Washer 3716 x 3/4 x 16 Ga.	34	532 12 75-34	Gasket, Cover
10	532 00 72-06	Spacer, Split	35	532 12 95-84	Container, Top
11	532 06 08-67	Nut, Acorn #10-24	36	532 12 95-86	Container, BoHom
12	810 07 10-00	Washer, Lock	37	532 13 46-37	Seal, Cover
13	532 10 98-08	Latch, Chute	38	532 13 08-95	Latch, Handle, Cover
14	532 00 20-29	Nut, Weld	39	532 13 98-54	Strip, Seal
15	532 13 07-60	Latch, Hook	40	532 04 19-45	Screw #10-24 x 1/2
16	532 13 07-59	Rubber, Latch	41	532 13 43-57	Bagger, Support Tube
18	532 12 68-39	Chute, Lower	42	532 13 98-58	Reinforcement Plate
20	532 04 19-45	Screw #10-24 x 5/8	43	817 49 06-40	Screw, 3/8-16 x 2-1/2 Hex, Self Tapping
21	532 13 27-96	Spring, Cover L.H. (black)	44	874 78 05-36	Bolt, Hex 5/16-18 x 2-1/4
22	532 14 08-09	Spacer, Cover	--	532 10 50-70	Bag, 3.0 mil. 30 Gallon Trash (not included with bagger)
23	532 13 29-83	Spring, Cover R.H. (gray)			
24	532 12 68-13	Post, Support			
25	532 06 31-24	Locknut 5/16 x 18			
26	532 08 59-02	Spring, Retainer			