

CTH140 Twin

Spare parts

Ersatzteile

Pièces détachées

Reserve onderdelen

Repuestos

Reservdelar

www.emc-motoculture.com

ILLUSTRATED PARTS LIST

MFG. ID NO. 96061018504

CUSTOMER CATALOG NO. CTH140TWIN

PRODUCT NO. 960 61 01-85

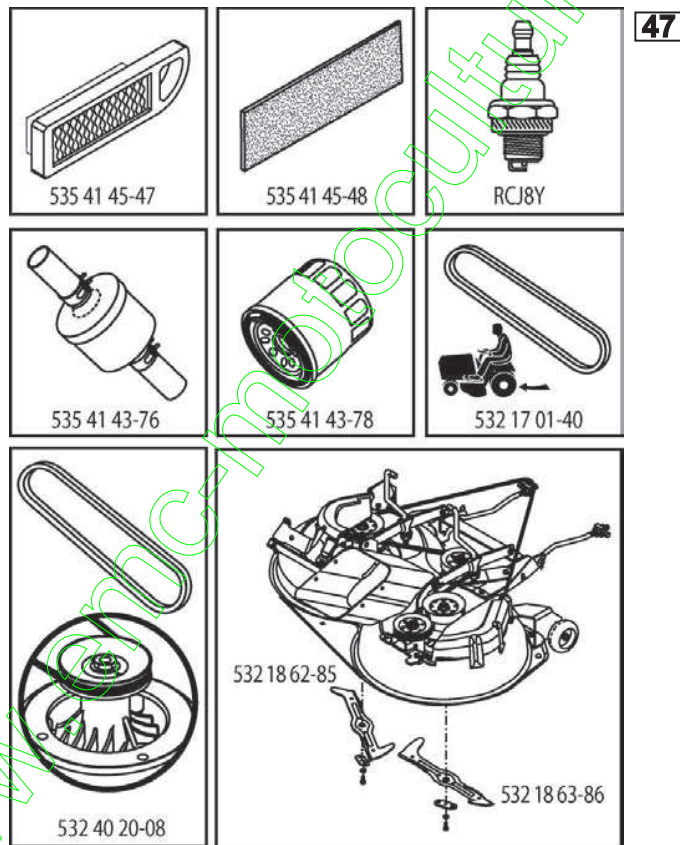

**TRACTOR -- MODEL NO. CTH140TWIN (96061018504), PRODUCT NO. 960 61 01-85
DECALS 27**

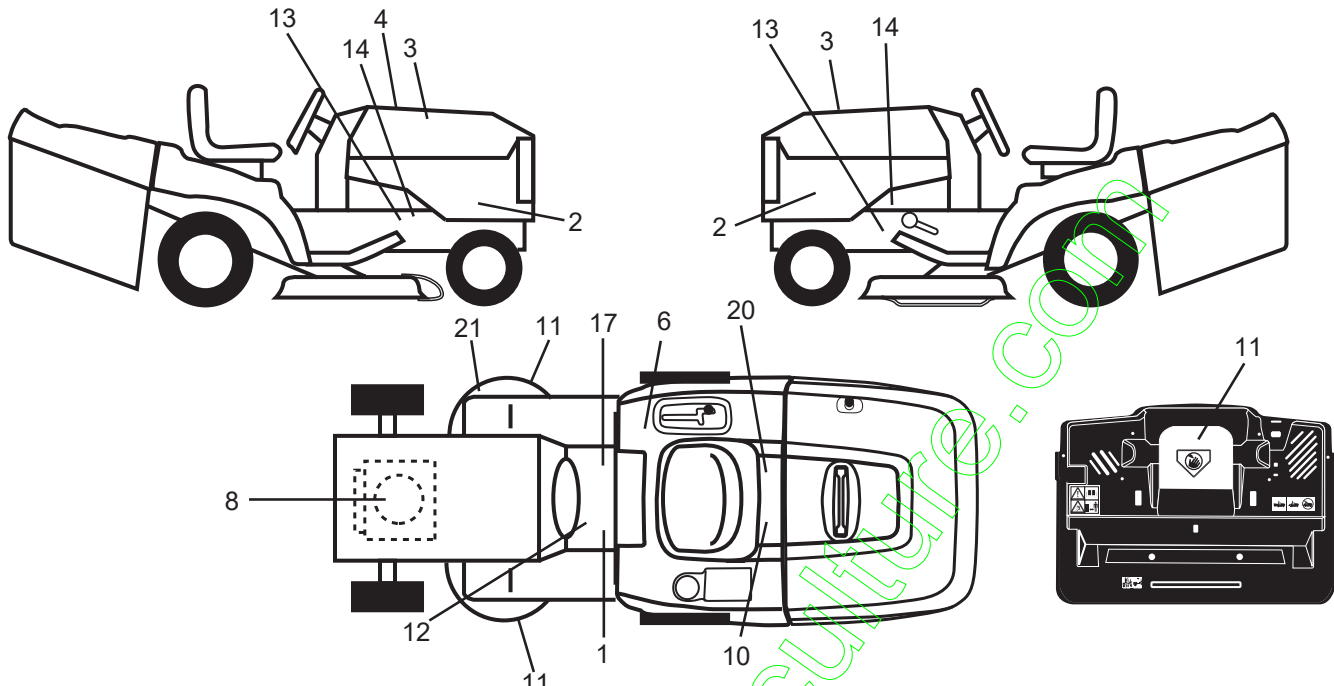

KEY NO.	PART NO.	DESCRIPTION
1	532 40 03-89	Decal Warning Symbols CE
2	532 41 09-69	Decal Sidepnl
3	532 42 20-12	Decal Hood
4	532 41 33-95	Decal Replacement
6	532 18 04-32	Decal Rear Plate CRD Symbols
8	532 19 68-41	Decal Warning Eng. Sym
10	532 14 50-05	Decal Bat Dan/Poi P/L Sym Wpn
11	532 18 21-66	Decal Mower Cut Finger Symbol
12	532 15 97-37	Decal Brake/Clutch Symbol Lt

KEY NO.	PART NO.	DESCRIPTION
13	532 40 11-46	Decal Warning Service/ Fire
14	532 15 97-36	Decal Chassis Hot Muffler
17	532 14 08-37	Decal Saddle Brake Parking
20	532 16 69-60	Decal Bypass Fender CRD
21	532 16 62-86	Decal Hex Belt Sch 92 CRD
--	532 13 83-11	Decal Lift Handle
--	532 18 04-35	Decal Backplate
--	532 18 19-17	Pad Footrest RH
--	532 18 19-16	Pad Footrest LH
--	532 40 92-23	Manual Operator's (Euro)

WHEELS & TIRES

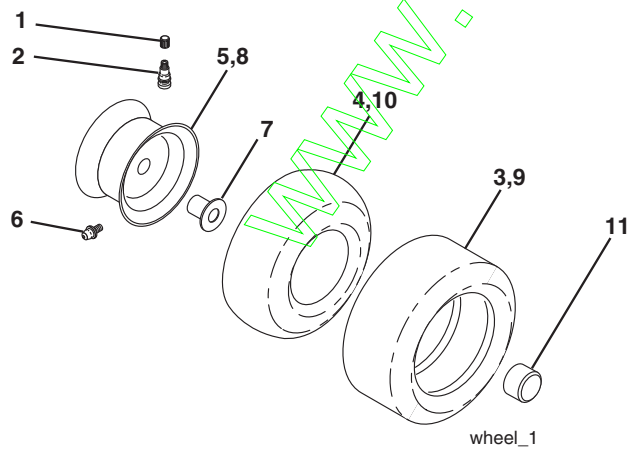

KEY NO.	PART NO.	DESCRIPTION
1	532 05 91-92	Cap Valve Tire
2	532 06 51-39	Stem Valve
3	532 10 62-22	Tire F Ts 15 x 6 0 - 6 Service
4	532 05 99-04	Tube Inner Front #35060
5	532 13 83-36	Rim Asm 6" Front Silver Service
6	532 12 49-57	Fitting Grease
7	532 12 49-59	Bearing Flange
8	532 13 83-37	Rim Asm 8" Rear Silver Service
9	532 12 20-82	Tire R Ts 20 x 10-8 Service
10	532 12 49-26	Tube Rear 9 5 x 8 Service
11	532 17 50-39	Cap Axle Blk 1 50 x 1 00
--	532 14 43-34	Sealant, Tire (10 oz. tube)

NOTE: All component dimensions given in U.S. inches
1 inch = 25.4 mm

TRACTOR -- MODEL NO. CTH140TWIN (96061018504), PRODUCT NO. 960 61 01-85 SCHEMATIC **38**

SCH05

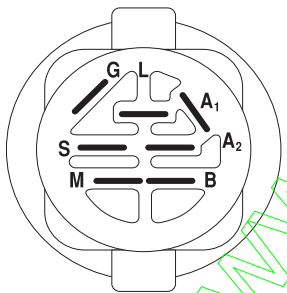
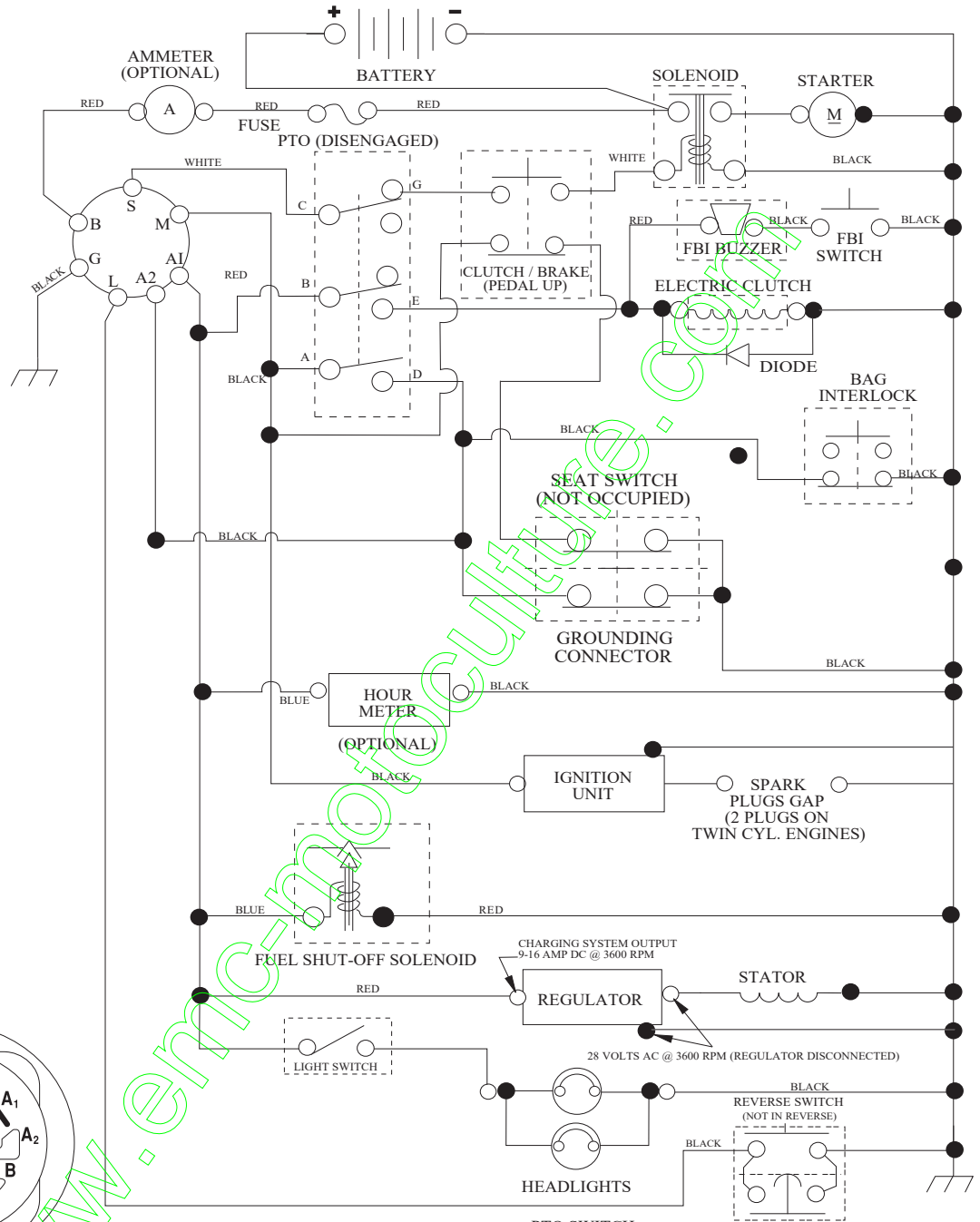

IGNITION SWITCH

POSITION	CIRCUIT "MAKE"
OFF	M+G+A1
RUN/OVERRIDE	B+A1
RUN	B+A1 L+A2
START	B + S + A1

WIRING INSULATED CLIPS
NOTE: IF WIRING INSULATED CLIPS WERE REMOVED FOR SERVICING OF UNIT, THEY SHOULD BE RE-INSTALLED TO PROPERLY SECURE YOUR WIRING.

03048

PTO SWITCH

POSITION	CIRCUIT
OFF	C + G, B + H
ON	C + F, B + E, A + D

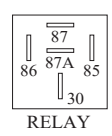

TRACTOR -- MODEL NO. CTH140TWIN (96061018504), PRODUCT NO. 960 61 01-85
ELECTRICAL 32

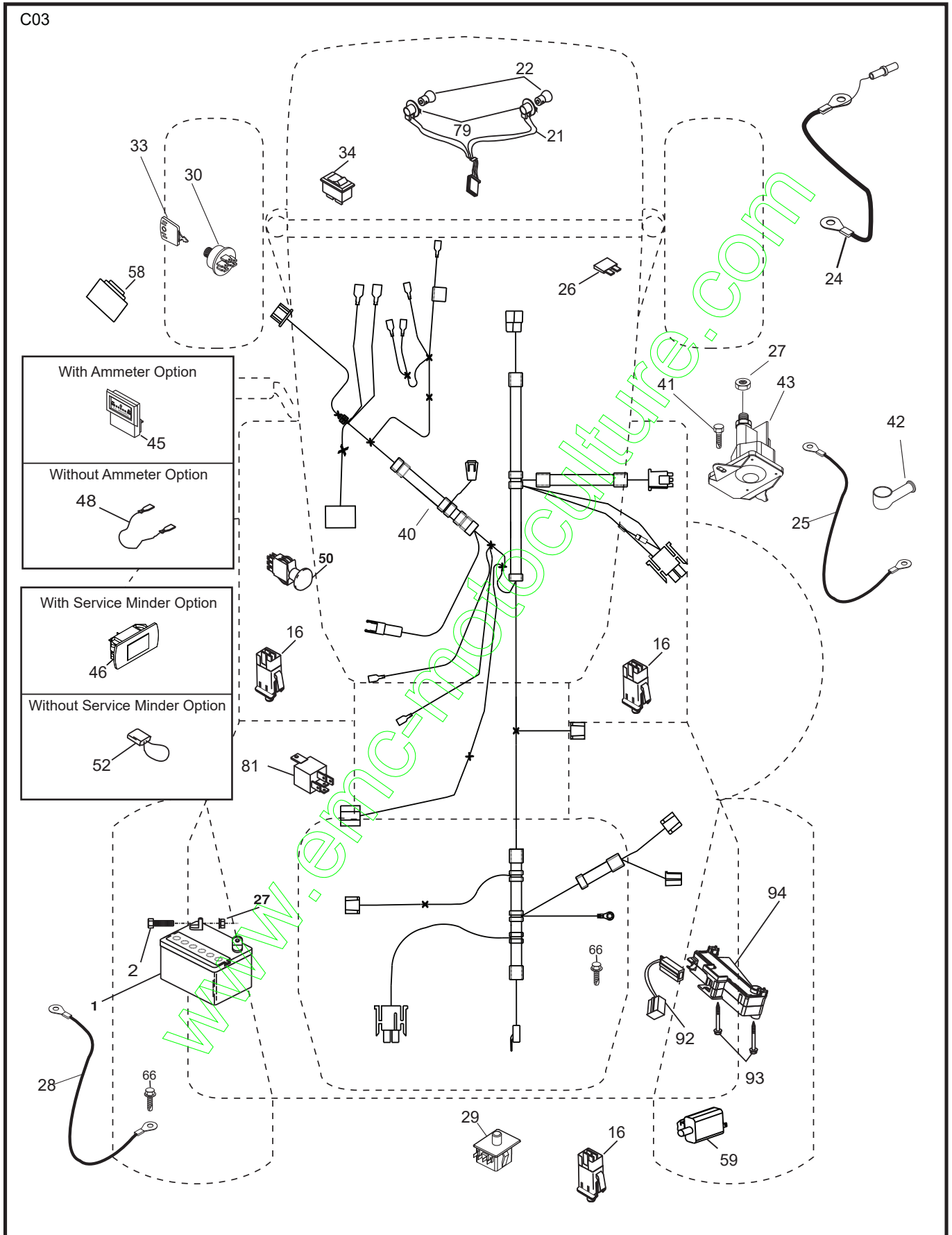

**TRACTOR -- MODEL NO. CTH140TWIN (96061018504), PRODUCT NO. 960 61 01-85
ELECTRICAL 32**

KEY NO.	PART NO.	DESCRIPTION
1	532 16 34-65	Battery
2	874 76 04-12	Bolt Hex Hd 1/4-20 unc x 3/4
16	532 17 61-38	Switch Interlock
21	532 40 02-52	Harness Asm Light w/4152J
22	532 00 41-52	Bulb Light #1156
24	532 12 47-80	Cable Starter 6 Ga. 11" Red
25	532 16 59-87	Cable Battery Crd 56" Red
26	532 17 51-58	Fuse
27	873 51 04-00	Nut Keps Hex 1/4-20 unc
28	532 12 77-25	Cable Ground 6 Ga. 18" Black
29	532 19 27-49	Switch Seat
30	532 19 33-50	Switch Ignition
33	532 41 19-35	Key/Chain
34	532 11 07-12	Switch Light
40	532 19 74-34	Harness Ign
41	871 11 04-08	Bolt Flk Fin Hex 1/4-20 unc x 1/2
42	532 13 15-63	Cover Terminal Red
43	532 19 25-07	Solenoid
46	532 41 39-31	Gauge SRVCMNDR HRMTR
48	532 14 08-44	Adapter Ammeter Rectangular
50	532 17 46-51	Switch PTO
58	532 16 94-19	Buzzer CRD
59	532 18 03-79	Switch FBI CRD
66	817 49 06-08	Screw Thdrol 3/8-16 x 1/2 Ty-Tt
79	532 17 52-42	Socket Asm. Bulb
81	532 10 97-48	Relay Asm
92	532 19 66-15	Harness Pigtail
93	532 19 25-40	Screw Plastite 10-44 x 2.0
94	532 19 18-34	Module Reverse

NOTE: All component dimensions given in U.S. inches.
1 inch = 25.4 mm.

TRACTOR -- MODEL NO. CTH140TWIN (96061018504), PRODUCT NO. 960 61 01-85
CHASSIS AND ENCLOSURES 39

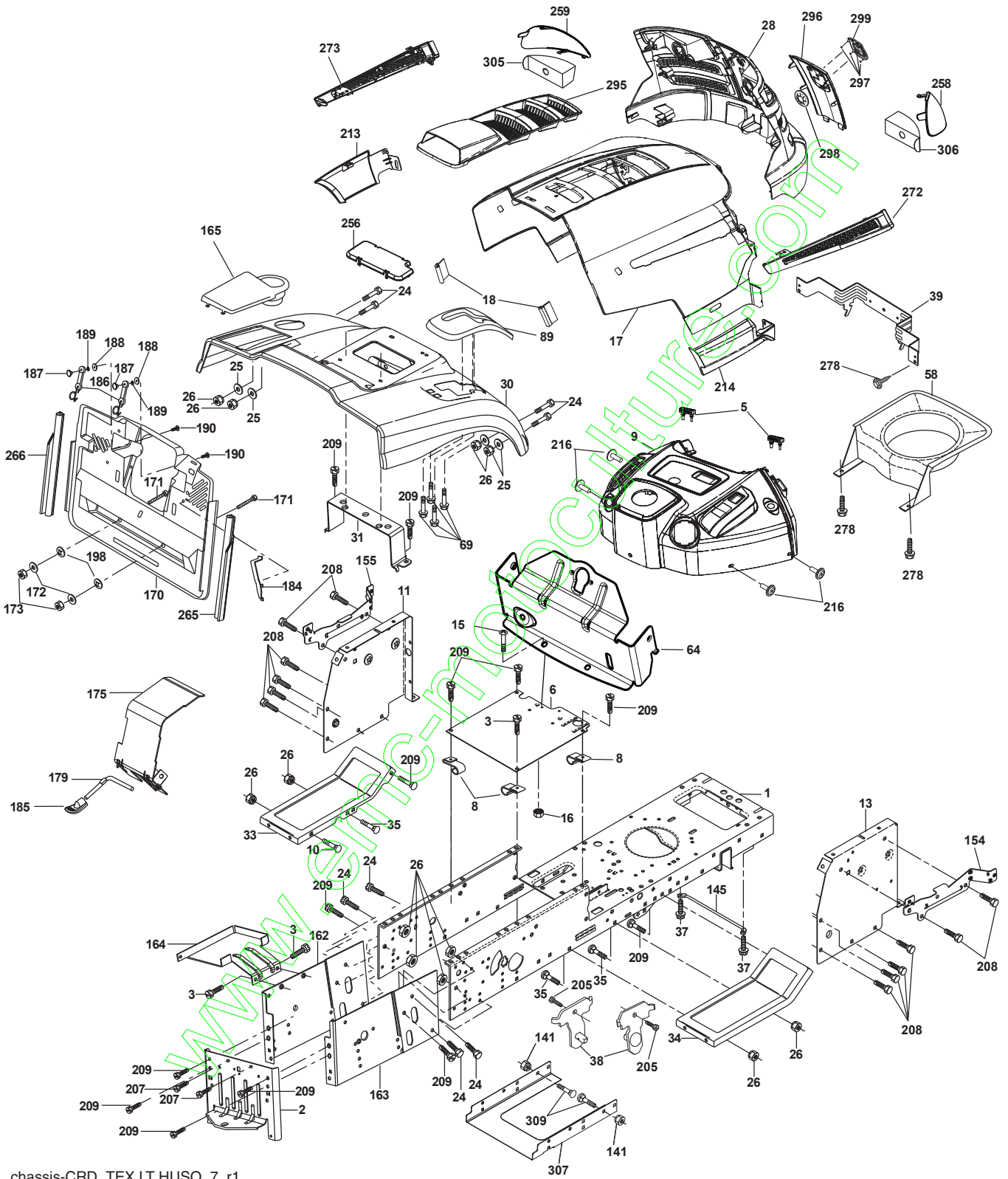

chassis-CRD_TEX LT HUSQ_7_r1

**TRACTOR -- MODEL NO. CTH140TWIN (96061018504), PRODUCT NO. 960 61 01-85
CHASSIS AND ENCLOSURES 39**

KEY NO.	PART NO.	DESCRIPTION	KEY NO.	PART NO.	DESCRIPTION
1	532 17 46-20	Chassis	172	819 13 20-16	Washer 13/32 x 1-1/4 x 16 Ga.
2	532 18 03-84	Drawbar	173	873 51 06-00	Nut, Keps Hex 3/8-16 unc
3	817 06 06-12	Screw 3/8-16 x 3/4	175	532 18 82-03	Guard Trap
5	532 40 75-90	Bumper Hood/Dash	179	532 18 82-02	Rod Pivot FBI CRD
6	532 18 44-19	Saddle	184	532 17 46-62	Bracket Actuator Bagger CRD
8	532 12 64-71	Clip Insulator 13/32 Mtg. Hole	185	532 18 11-01	Knob Rod Brake Parking
9	532 40 94-69	Dash Upper	186	532 16 07-93	Latch Asm Mulch/Bagger
10	872 14 06-08	Bolt, Carriage 3/8-16 x 3/4	187	532 12 50-04	Nut Weld
11	532 17 49-96	Panel, Dash, LH	188	819 06 12-16	Washer #10
13	532 17 21-06	Panel, Asm. Dash RH	189	810 07 10-00	Washer Lock #10
15	874 18 05-12	Screw, Machine, Truss Head 5/16-18 unc x 3/4	190	871 08 10-10	Screw Pan Hd Phillip 10-24 x 5/8
16	873 51 05-00	Nut	198	532 16 89-37	Nut, Push
17	532 41 10-73	Hood	205	817 49 06-08	Screw Thdrol 3/8-16 x 1/2
18	532 40 47-42	Bumper Hood	207	817 67 05-08	Screw Thdrol 5/16-18 x 1/2
24	874 78 06-16	Bolt	208	817 67 06-08	Screw Thdrol 3/8-16 x 1/2
25	819 13 13-12	Washer 13/32 x 13/16 x 12 Ga.	209	817 00 06-12	Screw Hex Wsh Thdrol 3/8-16
26	873 80 06-00	Nut	213	532 41 10-77	Skirt Side Husq LH
28	532 40-66-67	Grille/Lens Asm	214	532 41 10-76	Skirt Side Husq RH
30	532 19 73-76	Fender	216	817 67 04-12	Screw Hex Wsh Thdrol 1/4-20 x 3/4
31	532 16 51-56	Bracket, Fender Support	256	532 18 13-61	Cover Fender Rack
33	532 18 10-57	Footrest, LH	258	532 41 10-78	Lens RH
34	532 18 10-58	Footrest, RH	259	532 41 10-79	Lens LH
35	872 11 06-06	Bolt	265	532 18 57-04	Seal RH Side Bagger
37	817 49 05-08	Screw Thdrol 5/16-18 x 1/2 TYT	266	532 18 57-03	Seal LH Side Bagger
38	532 18 17-48	Bracket Asm Pivot Mower Rear	272	532 41 10-74	Vent Hood RH
39	532 40 78-07	Bracket Pivot	273	532 41 10-75	Vent Hood LH
58	532 40 66-62	Duct Air	278	532 41 63-58	Screw #10 x 0.750 BOS Thread
64	532 40 81-27	Dash Lower w/INF	295	532 41 11-16	Vent Top Hood
69	532 14 24-32	Screw Hx Wsh Hi-Lo 1/4-1/2	296	532 41 11-19	Trim
89	532 19 73-77	Console CRD Auto Grey	297	532 19 91-45	Clip Retainer
141	873 90 06-00	Nut	298	532 11 04-52	Nut Push
145	532 40 91-67	Rod Pivot Chassis/Hood	299	532 40 50-12	Logo Husq
154	532 40 81-22	Bracket Mtg Dash RH	305	532 40 66-65	Insert Lens Reflect LH
155	532 40 81-23	Bracket Mtg Dash LH	306	532 41 65-00	Insert Lens Reflect RH
162	532 18 03-82	Bracket Exten Chassis LH CRD	307	532 42 51-25	Shield Chassis Front
163	532 18 03-83	Bracket Exten Chassis RH CRD	309	872 11 06-06	Bolt RDHD SQNK 3/8-16 x 3/4
164	532 16 56-05	Support Battery CRD			
165	532 18 11-00	Cover Battery			
170	532 19 94-88	Backplate CRD			
171	872 14 06-20	Bolt Rdhd Sqnk 3/8-16 x 2-1/2 Gr. 5			

NOTE: All component dimensions given in U.S. inches.
1 inch = 25.4 mm.

TRACTOR -- MODEL NO. CTH140TWIN (96061018504), PRODUCT NO. 960 61 01-85
DRIVE **40**

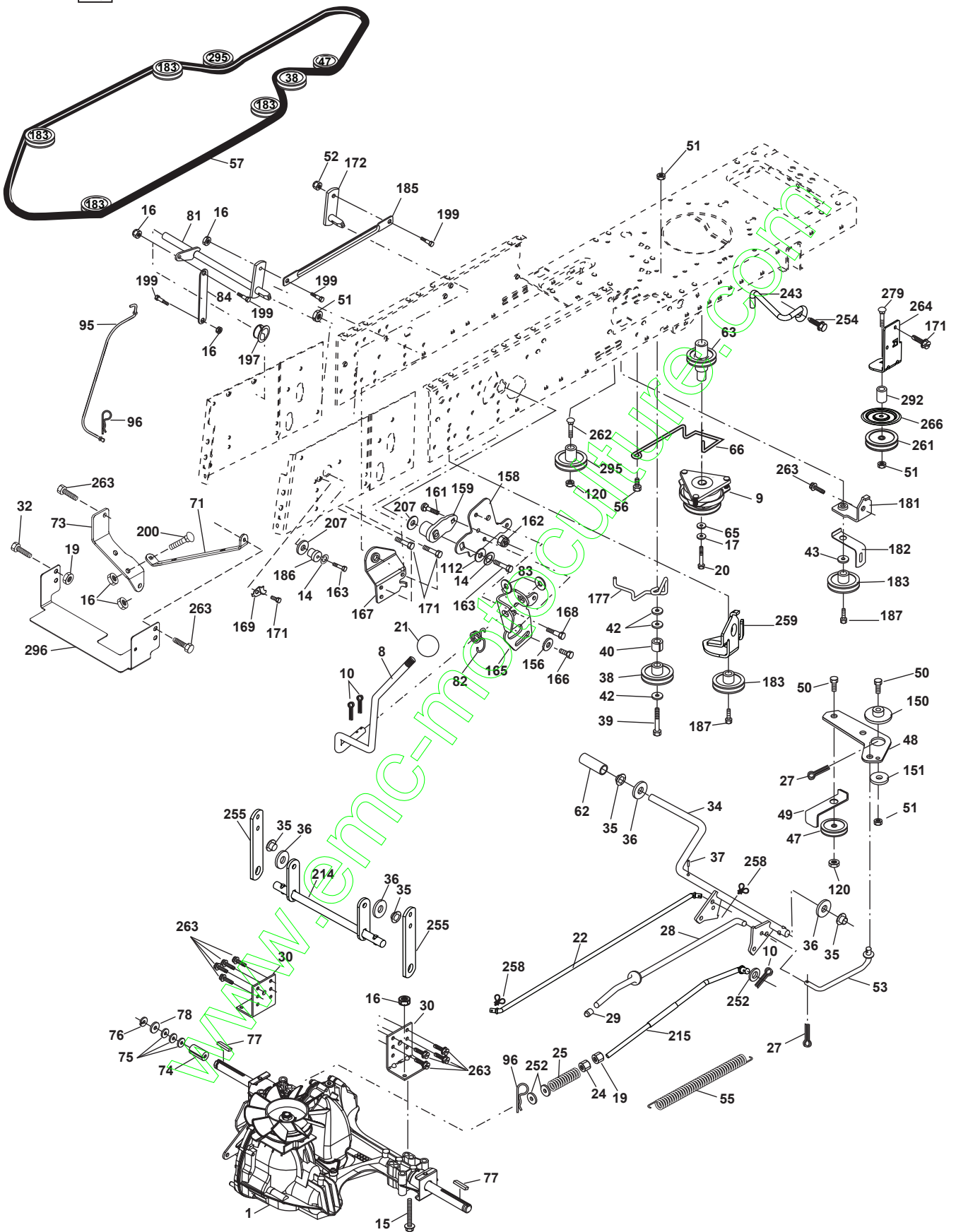

**TRACTOR -- MODEL NO. CTH140TWIN (96061018504), PRODUCT NO. 960 61 01-85
DRIVE **40****

KEY NO.	PART NO.	DESCRIPTION	KEY NO.	PART NO.	DESCRIPTION
1	-----	Transaxle Hydro Gear 321-0510	95	532 17 00-15	Control Asm Bypass Hydro
8	532 19 27-06	Rod, Shift Fender Adjust Lt	96	532 12 47-88	Spring, Retainer 1"
9	532 19 81-43	Clutch Asm Elect. Ogura	112	819 09 12-10	Washer 9/32 x 3/4 x 10 Ga.
10	876 02 04-16	Pin, Cotter 1/8 x 1	120	873 90 06-00	Nut Lock Fig. 3/8-16 unc
14	810 04 04-00	Washer, Lock Hvy Helical	150	532 16 58-50	Bushing, Bellcrank Grnd Dr
15	874 49 05-44	Bolt Hex FGHD 5/16-18 x Gr. 5	151	819 13 32-10	Washer 13/32 x 2 x 10 Ga.
16	873 80 05-00	Nut Lock Hex w/lns 5/16-18 unc	156	532 16 60-02	Washer Srrted 5/16 ID x 1.125
17	532 12 61-97	Washer 1-1/2 OD x 15/32 ID x .250	158	532 16 55-89	Bracket Shift Mount
19	873 80 06-00	Nut Lock Hex w/lns 3/8-16 unc	159	532 18 39-00	Hub Shift
20	532 17 39-37	Bolt Hex 7/16-20 x 4 x Gr. 5 - 1.5	161	872 14 04-06	Bolt Rdhd Sqnk 1/4-20 x 3/4 Gr. 5
21	532 12 12-74	Knob Duckhead 1/4-13 unc Blk	162	873 68 04-00	Nut Crownlock 1/4-20 unc
22	532 17 56-07	Brake Rod	163	874 78 04-16	Bolt Hex Fin 1/4-20 unc x 1 Gr. 5
24	873 35 06-00	Nut Hex Jam 3/8-16 unc	165	532 16 56-23	Bracket Pivot Lever
25	532 19 20-36	Spring Rod Brake	166	817 49 05-10	Screw 5/16-18 x 5/8
27	876 02 04-12	Pin, Cotter 1/8 x 3/4	167	532 16 55-88	Bracket Support Shift CRD
28	532 17 57-65	Rod, Parking Brake	168	532 16 54-92	Bolt Shoulder 5/16-18 x .561
29	532 07 16-73	Cap, Parking Brake	169	532 16 55-80	Plate Fastening Lt
30	532 16 95-92	Bracket, Mfg. Transaxle	171	817 49 06-08	Screw Thdrol 3/8-16 x 1/2 Ty-Tt
34	532 17 55-78	Shaft, Asm Pedal Foot CRD	172	532 17 02-71	Shaft Asm Shifter Frt CRD
35	532 12 01-83	Bearing, Nylon	177	532 16 59-32	Keeper Flat Idler 3.06" CRD
36	819 21 16-16	Washer 21/32 x 1 x 16 Ga.	181	532 18 02-11	Bracket Idler Ground Drive CRD
37	532 12 49-63	Pin, Roll 3/16 x 1"	182	532 18 26-82	Keeper Belt 2.5" Od V-Idler CRD
38	532 16 59-36	Pulley Flat Composite 3.06"	183	532 19 95-32	Pulley V-Idler CRD
39	874 76 06-44	Bolt Fin Hex 3/8-16 unc x 2-3/4	185	532 17 00-08	Link Shift
40	532 12 49-65	Spacer, Split 395 x 59 Bzp	186	532 16 56-14	Hub Tapered Round CRD
42	819 13 13-12	Washer 13/32 x 13/16 x 12 Ga.	187	817 58 05-20	Screw Thdrol 5/16-18 x 1.25
43	819 11 10-12	Washer 11/32 x 5/8 x 12 Ga.	197	532 16 96-13	Nyliner Snap-In 5/8
47	532 12 77-83	Pulley, Idler, V Groove Plastic	199	532 16 96-12	Bolt Shoulder 5/16-18 unc
48	532 15 44-07	Bellcrank Clutch Grnd Drv	200	872 14 05-08	Bolt RDHD SQNK 5/16-18 x 1
49	532 12 32-05	Retainer, Belt Style Spring	207	532 16 98-45	Washer Nylon Rear
50	872 11 06-12	Bolt Carr. Sh. 3/8-16 x 1-1/2 Gr. 5	214	532 17 56-09	Shaft Asm. Brake
51	873 68 06-00	Nut, Crownlock 3/8-16 unc	215	532 17 56-52	Rod Brake Hydro
52	873 68 05-00	Nut, Crownlock 5/16-18 unc	243	532 19 07-36	Bracket Anti-Rotation
53	532 19 96-52	Link, Clutch 7.66	252	819 13 16-16	Washer 13/32 x 1 x 16 Ga.
55	532 10 57-09	Spring, Return, Clutch	254	817 00 06-16	Screw 3/8-16 x 1
56	817 06 06-20	Screw 3/8-16 x 1-1/4	255	532 17 56-08	Brace Shaft Brake Mtg.
57	532 17 01-40	V-Belt Kev 112" 0650 CRD	258	532 17 80-62	Clip Retainer
62	532 12 48-72	Cover, Pedal	259	532 18 02-12	Bracket Pulley
63	532 18 03-97	Pulley Eng.	261	532 13 14-94	Pulley Idler
65	810 04 07-00	Washer	262	872 11 06-22	Bolt Carr. 3/8-16 x 2-3/4 Gr. 5
66	532 15 47-78	Keeper, Belt Engine F-Proof	263	817 00 06-12	Screw 3/8-16 x 3/4
71	532 16 91-83	Strap, Torque, LH	264	532 19 76-07	Bracket Idler Chassis
73	532 16 91-82	Strap, Torque, RH	266	532 18 20-61	Shield Idler Mower
74	532 13 70-57	Spacer, Split	279	872 11 06-16	Bolt 3/8-16 unc x 2
75	532 12 17-49	Washer 25/32 x 1-1/4 x 16 Ga.	292	532 40 02-71	Spacer Noram CRD
76	812 00 00-01	Ring, E	295	532 17 91-14	Pulley Idler Composite
77	532 12 35-83	Key, Square	296	532 42 09-20	Shield Chassis Rear
78	532 12 17-48	Washer 25/32 x 1-5/8 x 16 Ga.			
81	532 17 00-06	Asm, Shaft, Cross Rear			
82	532 16 57-11	Spring, Torsion			
83	819 17 12-16	Washer 17/32 x 3/4 x 16 Ga.			
84	532 17 00-07	Link, Transaxle			

NOTE: All component dimensions given in U.S. inches
1 inch = 25.4 mm

**TRACTOR -- MODEL NO. CTH140TWIN (96061018504), PRODUCT NO. 960 61 01-85
ENGINE 24**

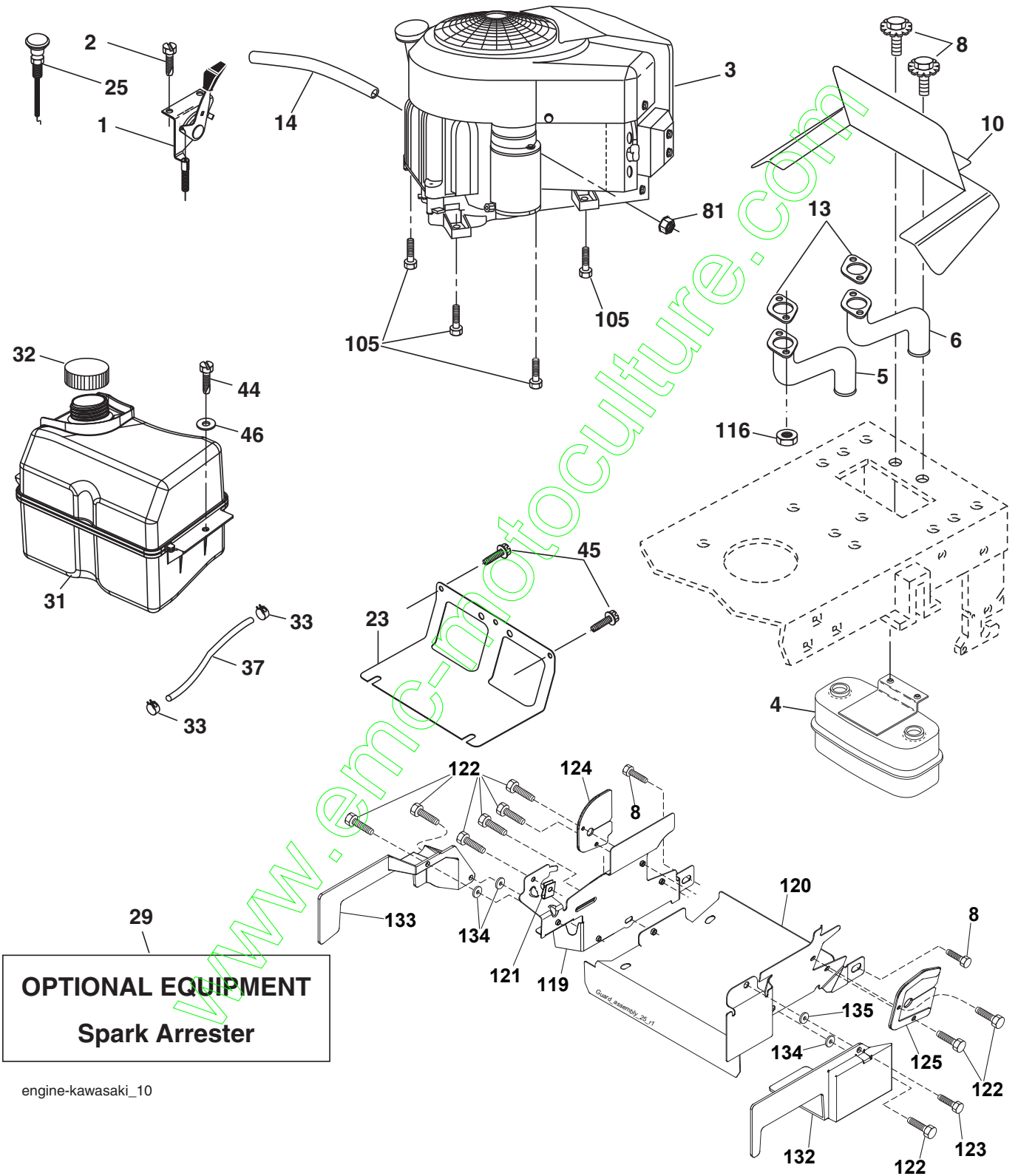

**TRACTOR -- MODEL NO. CTH140TWIN (96061018504), PRODUCT NO. 960 61 01-85
ENGINE 24**

KEY NO.	PART NO.	DESCRIPTION
1	532 41 21-65	Control Throt/Ck
2	532 41 63-58	Screw #10 x 0.750 BOS Thread
3	-----	Engine Kawasaki FH430V
4	532 14 97-23	Muffler
5	532 18 14-44	Exhaust Tube LH
6	532 18 14-42	Exhaust Tube RH
8	532 17 18-77	Bolt 5/16-18 unc x 3/4 w/Sems
10	532 14 66-29	Shield Heat
13	-----	Gasket Muffler
14	532 14 84-56	Tube Drain Oil Easy
23	532 16 98-37	Shield Brn/Dbr Guard
25	532 19 15-96	Control Choke
29	532 13 71-80	Kit Spark Arrestor (Flat Scrn)
31	532 40 75-45	Tank Fuel
32	532 19 77-25	Cap Asm Fuel W/sym Vented
33	532 12 34-87	Clamp Hose Bk
37	532 13 70-40	Line Fuel
44	817 67 04-12	Screw Hexwsh Thdrol 1/4-20 x 3/4
45	817 00 06-12	Screw Hexwsh Thdr 3/8-16 x 3/4
46	819 09 14-16	Washer 9/32 x 7/8 x 16 Ga.
81	873 51 04-00	Nut Keps Hex 1/4-20 unc
105	817 12 06-16	Screw 3/8-16 x 1
116	532 18 43-62	Nut Hex Flange Toplock M8-1.25
119	532 19 97-68	Guard Asm. Engine LH
120	532 19 97-67	Guard Asm. Engine RH
121	532 19 66-88	Clip Threaded
122	532 13 77-29	Screw Thdrol 1/4-20 x 5/8
123	817 67 05-08	Screw Thdrol 5/16-18 x 1/2
124	532 19 97-72	Rod Tie Guard LH
125	532 19 97-73	Rod Tie Guard RH
132	532 42 07-57	Shield Side RH
133	532 42 07-56	Shield Side LH
134	532 42 30-62	1/4 PAL Nut
135	532 42 30-63	5/16 PAL Nut

NOTE: All component dimensions given in U.S. inches
1 inch = 25.4 mm

TRACTOR -- MODEL NO. CTH140TWIN (96061018504), PRODUCT NO. 960 61 01-85
STEERING ASSEMBLY 41

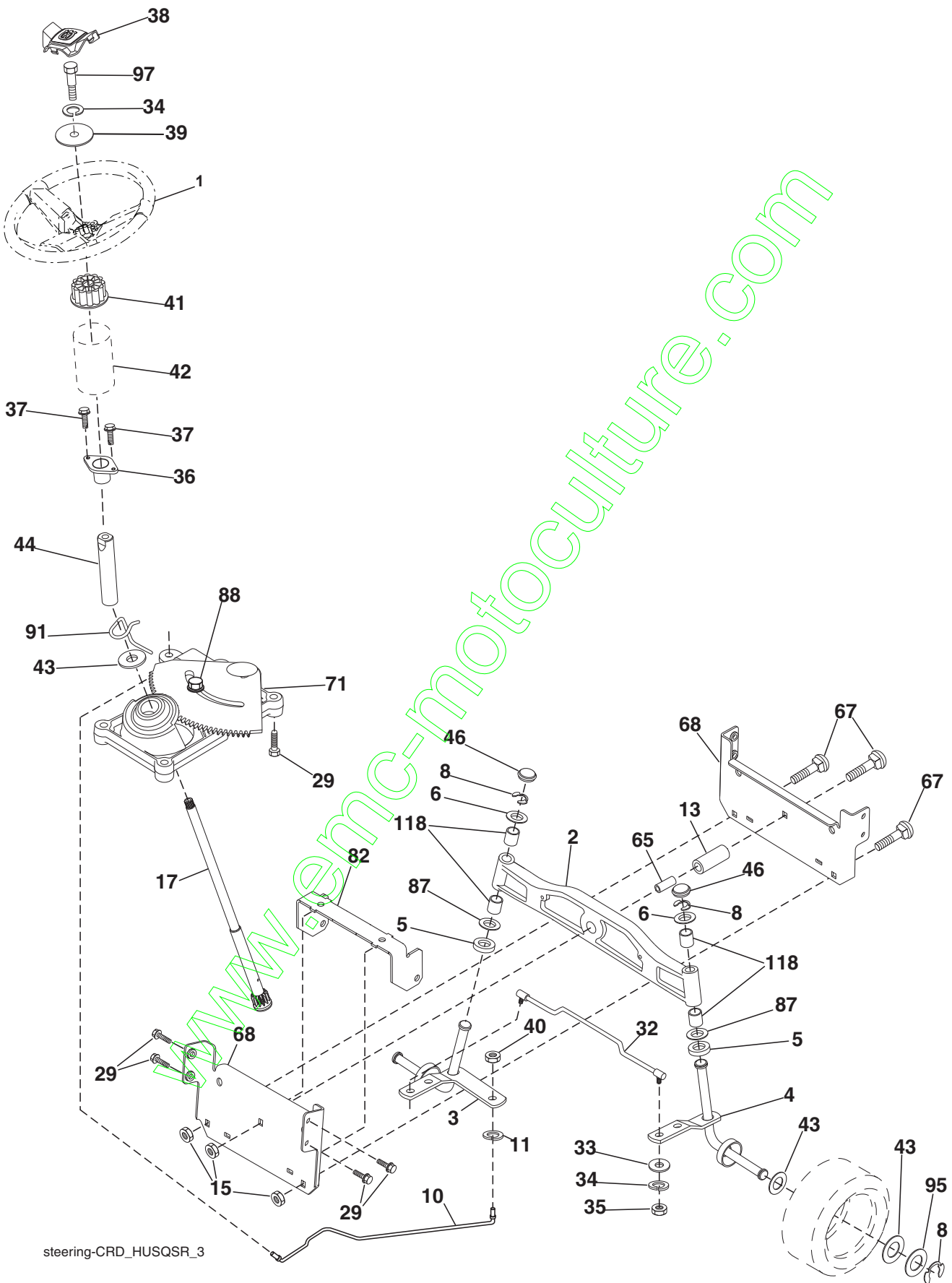

steering-CRD_HUSQSR_3

**TRACTOR -- MODEL NO. CTH140TWIN (96061018504), PRODUCT NO. 960 61 01-85
STEERING ASSEMBLY 41**

KEY NO.	PART NO.	DESCRIPTION
1	532 41 64-80	Steering Wheel
2	532 19 35-42	Front Axle Assembly
3	532 16 98-40	Spindle Assembly, LH
4	532 16 98-39	Spindle Assembly, RH
5	532 12 49-31	Bearing, Race, Thrust, Hardened
6	532 12 17-48	Washer 25/32 x 1-5/8 x 16 Ga.
8	812 00 00-29	Ring, Clip
10	532 17 51-21	Link, Drag
11	810 04 06-00	Washer, Lock
13	532 13 65-18	Spacer Axle
15	532 14 52-12	Nut Hex Flange Lock
17	532 19 07-53	Shaft Assembly, Steering
29	817 00 06-12	Screw 3/8-16 x 3/4
32	532 17 18-88	Rod, Tie
33	819 11 12-16	Washer 11/32 x 3/4 x 16 Ga.
34	810 04 05-00	Washer Lock Hvy Hlcl Spr 5/16
35	873 54 05-00	Crownlock Nut 5/16-24 unf
36	532 15 50-99	Bushing, Steering
37	532 15 29-27	Screw TT #10-32 x 5 x 3/8 Flange
38	532 41 59-87	Cap Wheel Steering
39	819 11 38-12	Washer 11/32 ID x 2-3/8 OD x 12 Ga.
40	873 54 06-00	Nut Crownlock 3/8-24
41	532 18 67-37	Adaptor, Steering Wheel
42	532 41 11-39	Boot, Steering Dash P/L Mtl
43	532 12 17-49	Washer 25/32 x 1-1/4 x 16 Ga.
44	532 19 07-52	Extension Steering
46	532 12 12-32	Cap, Spindle
65	532 41 47-36	Spacer Axle
67	872 11 06-18	Bolt Rdhd Sq 3/8-16 x 2-1/4
68	532 16 98-27	Brace Axle
71	532 17 51-46	Steering Asm.
82	532 19 99-78	Bracket Susp. Chassis Front
87	532 17 39-66	Washer Flat .781 x 1-1/2 x .14
88	532 17 51-18	Bolt Shoulder 7/16-20 unc
91	532 17 55-53	Clip Steering
95	532 18 89-67	Washer
97	874 78 05-64	Bolt 5/16-18 unc x 4" L Gr. 5
118	532 40 60-13	Bushing

NOTE: All component dimensions given in U.S. inches.
1 inch = 25.4 mm.

TRACTOR -- MODEL NO. CTH140TWIN (96061018504), PRODUCT NO. 960 61 01-85
MOWER DECK 44

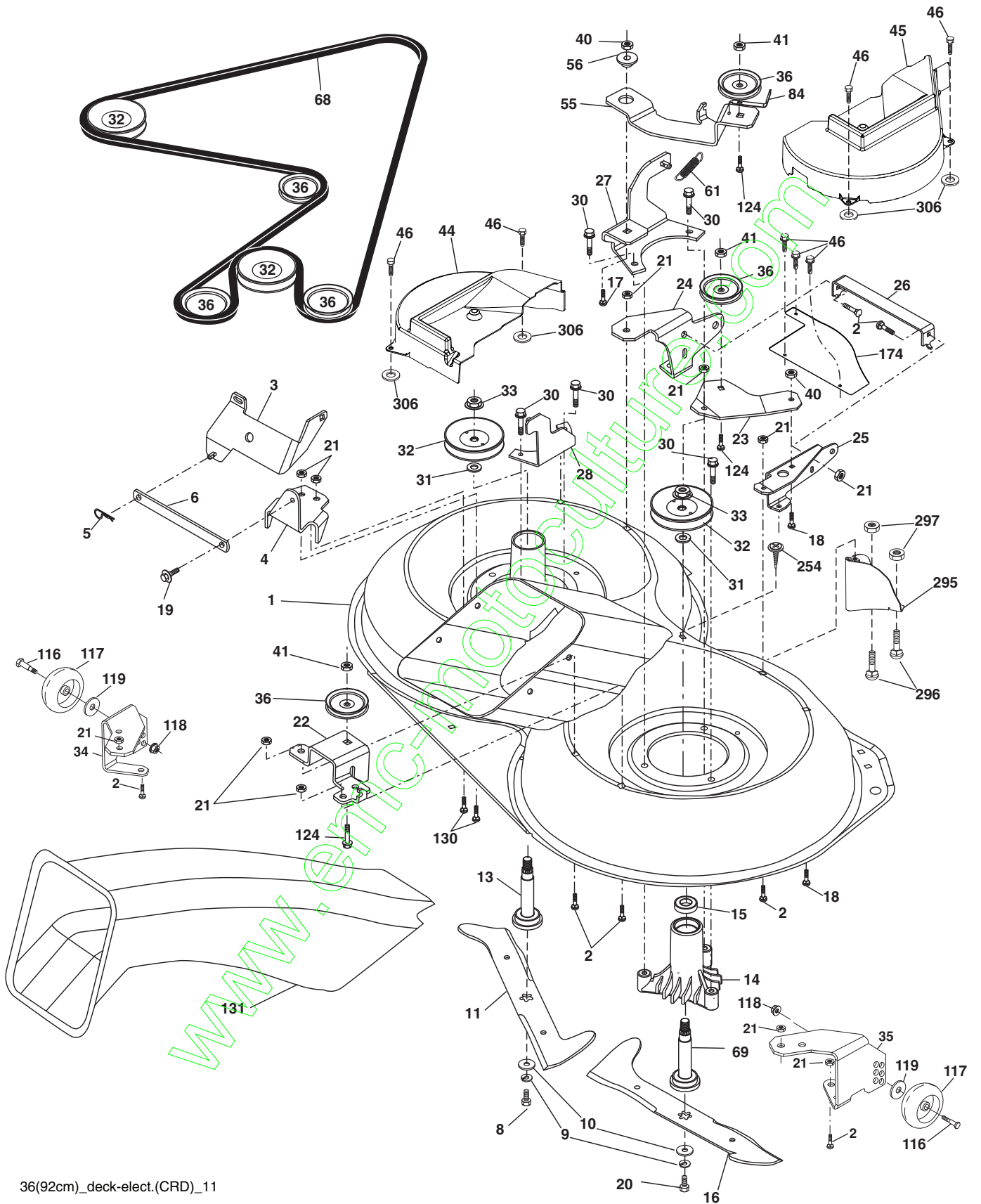

36(92cm)_deck-elect.(CRD)_11

**TRACTOR -- MODEL NO. CTH140TWIN (96061018504), PRODUCT NO. 960 61 01-85
MOWER DECK **44****

KEY NO.	PART NO.	DESCRIPTION	KEY NO.	PART NO.	DESCRIPTION
1	532 40 01-08	Housing Asm. Mower 92 CRD	41	873 90 06-00	Nut Lock Flg. 3/8-16 unc
2	872 14 05-06	Bolt Rdhd Sqnk 5/16-18 unc x 3/4	44	532 42 07-52	Cover Mandrel LH 92 CRD
3	532 16 55-69	Bracket Asm. S-Bar Chass 92 CRD	45	532 42 07-53	Cover Mandrel RH 92 CRD
4	532 16 55-58	Bracket Bar Sway Deck 92 CRD	46	532 13 77-29	Screw Thd Roll 1/4-20 x 5/8
5	532 12 46-70	Retainer Spring	55	532 19 94-98	Arm Idler 92 CRD
6	532 16 55-57	Bar Sway 92 CRD	56	532 16 57-23	Spacer Retainer Mower
8	532 18 17-12	Bolt 3/8-24 x 1.25 Gr. 8 Patched	61	532 19 94-86	Spring Tension Belt
9	810 03 06-00	Washer Lock Hvy 3/8 Unplated	68	532 40 20-08	Hex-Belt 92 Mower
10	532 14 02-96	Washer Hard Blade	69	532 16 54-82	Shaft Asm w/Lwr Brg RH Thd CRD
11	532 18 63-85	Blade 3-1 LH 92 CRD	84	532 15 60-85	Keeper Belt Idler
13	532 13 76-45	Shaft Asm. w/Lower Bearing	116	532 19 34-06	Bolt Shoulder
14	532 12 87-74	Housing Mandrel Vented (Machd)	117	532 17 48-73	Wheel Gauge
15	532 11 04-85	Bearing Ball Mandrel	118	873 90 06-00	Nut Centerlock 3/8-16 unc
16	532 18 63-86	Blade 3-1 RH 92 CRD	119	819 13 20-12	Washer 13/32 x 1-1/4 x 12
17	872 14 06-10	Bolt Carriage 3/8-16 x 1-1/4	124	872 11 06-12	Bolt Carr Sh 3/8-16 x 1-1/2 Gr. 5
18	872 11 06-06	Bolt Rdhd Sqnk 3/8-16 x 3/4	130	872 11 05-06	Bolt Rdhdsqnk 5/16-18 unc x 3/4
19	532 13 28-27	Bolt Shoulder 5/16-18 Thd Form	131	532 16 56-61	Chute Bagger CRD 92cm
20	532 18 17-13	Bolt 3/8-24 x 1.25 Gr. 8 Ptch Lhthd	174	532 40 02-41	Guard Susp Front
21	873 68 05-00	Nut Crown Lock 5/16-18	254	817 00 06-16	Screw 3/8-16 x 1
22	532 19 95-90	Bracket Idler Sprt 92 CRD	295	532 41 21-71	Baffle Front
23	532 16 54-46	Bracket Idler Sprt RF 92 CRD	296	872 14 04-06	Bolt RDHD SQNK 1/4 - 20x3/4 Gr. 5
24	532 16 52-42	Bracket Suspension LF 92 CRD	297	873 93 04-00	Nut Centerlock 1/4 - 20 unc
25	532 16 52-44	Bracket Suspension RF 92 CRD	306	532 42 30-62	1/4" Pal Nut
26	532 40 01-10	Brace Susp Frt CRD	---	532 18 18-57	Mandrel Assembly (Includes housing, shaft assembly, and bearing only - pulley/nut/washer and blade bolt/washers not included)
27	532 16 55-68	Bracket Asm. Susp RR 92 CRD	---	532 18 18-58	Mandrel Asm CRD LH Threads SVC
28	532 16 55-67	Bracket Asm. Susp LR 92 CRD	---	532 42 27-85	Replacement Mower, Complete (Std. Deck - Order separately gauge wheel components key nos. 116 - 119)
30	532 17 39-84	Screw Thd Rolling			
31	532 18 76-90	Washer Spacer Mower Vented			
32	532 15 35-32	Mandrel Pulleys			
33	532 40 02-34	Nut Flg Top Lock			
34	532 40 01-07	Bracket Gauge Wheel LF 92 CRD			
35	532 40 01-06	Bracket Gauge Wheel RF 92 CRD			
36	532 14 67-63	Pulley Idler V-Groove Dim 4.25			
40	873 68 06-00	Nut Crownlock 3/8-16 unc			

NOTE: All component dimensions given in U.S. inches
1 inch = 25.4 mm

TRACTOR -- MODEL NO. CTH140TWIN (96061018504), PRODUCT NO. 960 61 01-85
 MOWER LIFT **45**

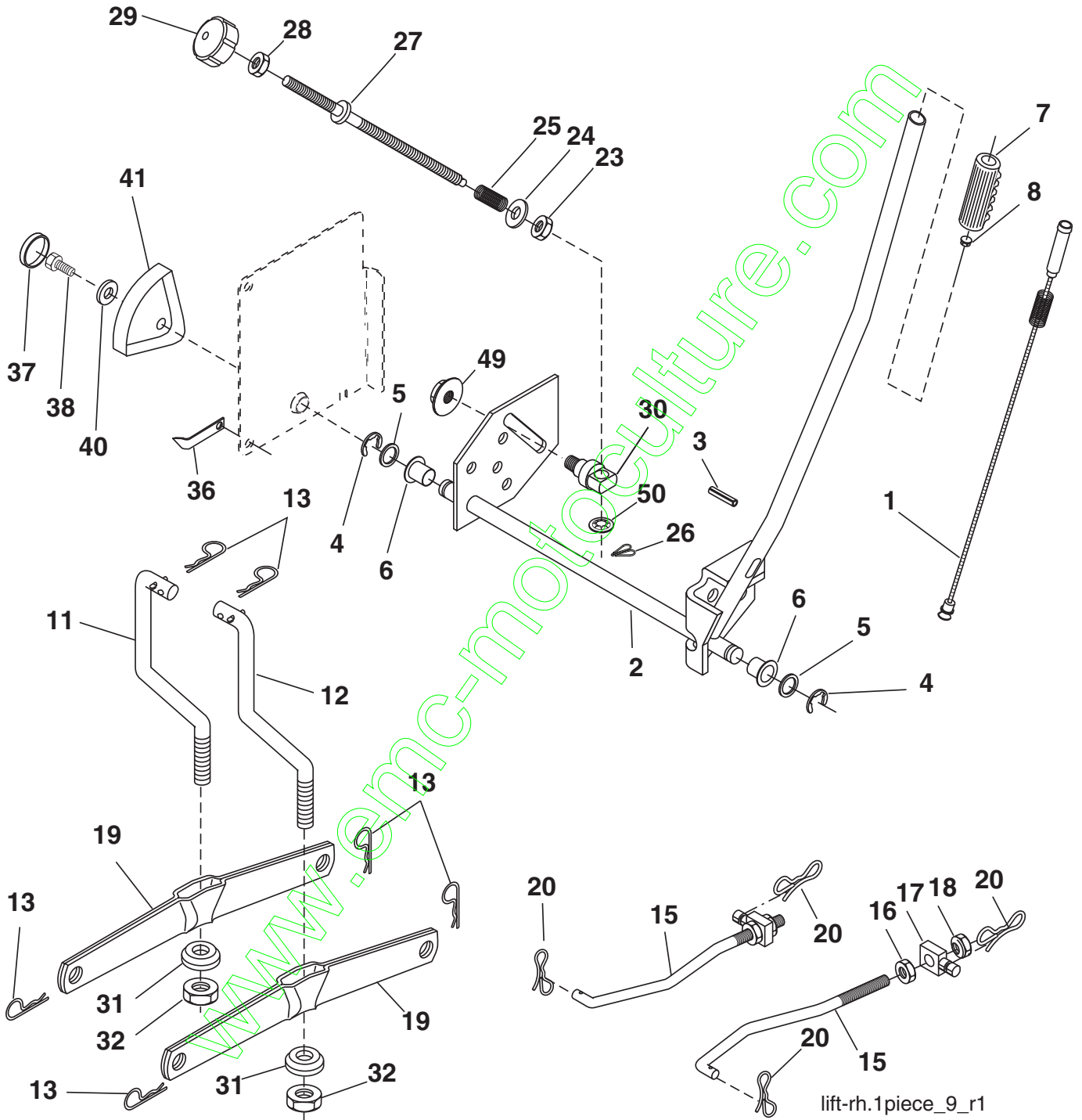

**TRACTOR -- MODEL NO. CTH140TWIN (96061018504), PRODUCT NO. 960 61 01-85
MOWER LIFT 45**

KEY NO.	PART NO.	DESCRIPTION
1	532 40 49-81	Plunger Asm. Lift Lever
2	532 15 94-71	Shaft Asm. Lift
3	532 10 57-67	Pin Groove
4	812 00 00-02	E Ring #5133-62
5	819 21 16-21	Washer 21/32 x 1 x 21 Ga.
6	532 12 01-83	Bearing Nylon
7	532 12 56-31	Grip Handle Fluted
8	532 12 45-26	Button Plunger Black
11	532 16 58-29	Link Asm Lift LH
12	532 16 58-31	Link Asm Lift RH
13	532 12 46-70	Retainer Spring
15	532 17 32-88	Link Front
16	873 35 08-00	Nut Jam Hex 1/2-13 unc
17	532 17 56-89	Trunnion Blk Zinc
18	873 80 08-00	Nut Lock w/Wsh 1/2-13 unc
19	532 13 98-68	Arm Suspension Mower
20	532 19 42-09	Pin Cotter 7/16 Bowtie Lock
23	532 11 08-07	Nut Special
24	819 13 10-16	Washer 13/32 x 5/8 x 16 Ga.
25	532 16 40-24	Spring 2-1/8"
26	532 16 94-84	Retainer Clip
27	532 16 45-43	Rod Adj Lift Zinc 7.49 Wrk Lg
28	873 35 06-00	Nut Hex Jam 3/8-16 unc
29	532 13 80-57	Knob Inf 3/8-16 unc Blk w/sym
30	532 15 02-33	Trunnion Infin Height
31	532 16 98-65	Bearing, Pvt. Lift.
32	873 54 06-00	Nut Crownlock 3/8-24
36	532 15 50-97	Pointer Height Indicator
37	532 12 39-35	Plug Hole Blk 1.485/1.515 Dia
38	817 06 05-16	Screw 5/16-18 x 1
40	819 11 24-10	Washer 11/32 x 1-1/2 x 10 Ga.
41	532 12 39-34	Scale Ind Height Blk
49	532 14 52-12	Nut hex Flange Lock
50	532 11 04-52	Nut Push Phos & Oil

NOTE: All component dimensions given in U.S. inches
1 inch = 25.4 mm

**TRACTOR -- MODEL NO. CTH140TWIN (96061018504), PRODUCT NO. 960 61 01-85
SEAT ASSEMBLY 42**

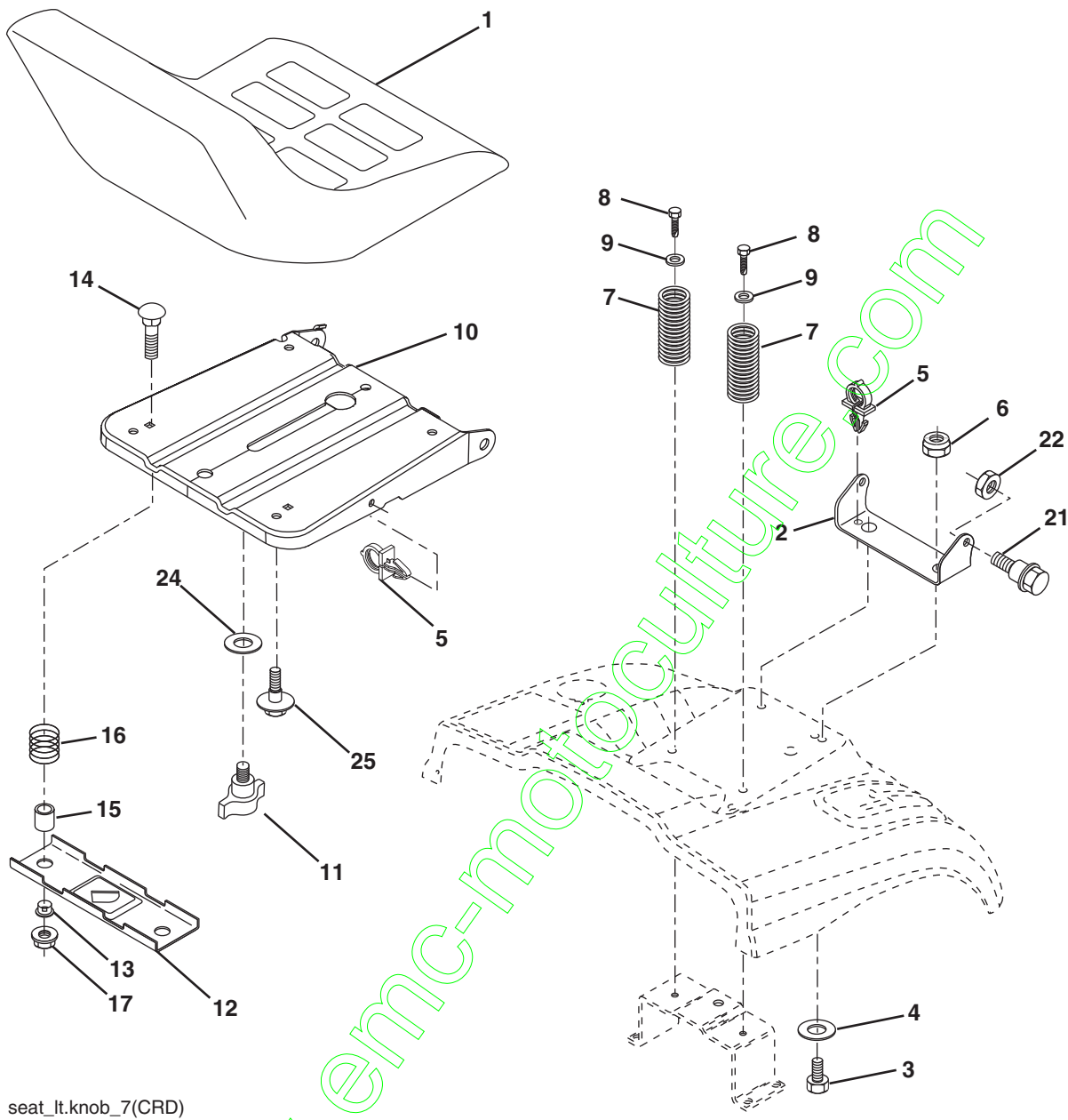

seat_lt.knob_7(CRD)

KEY NO.	PART NO.	DESCRIPTION
1	532 18 87-15	Seat
2	532 14 05-51	Bracket Pnt Pivot Seat (Blk)
3	871 11 06-16	Bolt Fin Hex 3/8-16 x 1
4	819 13 16-10	Washer Flat 13/32 x 1 x 10 Ga.
5	532 14 50-06	Clip Push In Hinged
6	873 80 06-00	Nut Lock Hex w/Ins 3/8-16
7	532 12 41-81	Spring Seat Cprsn 2 250 Blk Zi
8	817 00 06-16	Screw 3/8-16 x 1.5
9	819 13 16-14	Washer 13/32 x 1 x 14 Ga.
10	532 19 55-30	Pan Pnt Seat
11	532 16 63-69	Knob Seat Adj. Wingnut
12	532 17 46-48	Bracket Pnt Mounting Switch

KEY NO.	PART NO.	DESCRIPTION
13	532 12 12-48	Bushing Snap Blk Nyl 50 Id
14	872 05 04-12	Bolt Rdhd Sht Nk 1/4-20 x 1-1/2
15	532 12 12-49	Spacer Split
16	532 12 37-40	Spring Cprsn
17	532 12 39-76	Nut Lock 1/4 Lge Flg Gr. 5 Zinc
21	532 17 18-52	Bolt Shoulder 5/16-18 unc-2A
22	873 80 05-00	Nut Hex Lock w/Ins 5/16-18
24	819 17 19-12	Washer 17/32 x 1-3/16 x 12 Ga.
25	532 12 70-18	Bolt Shoulder 5/16-18 x 62

NOTE: All component dimensions given in U.S. inches.
1 inch = 25.4 mm

**TRACTOR -- MODEL NO. CTH140TWIN (96061018504), PRODUCT NO. 960 61 01-85
BAGGER 46**

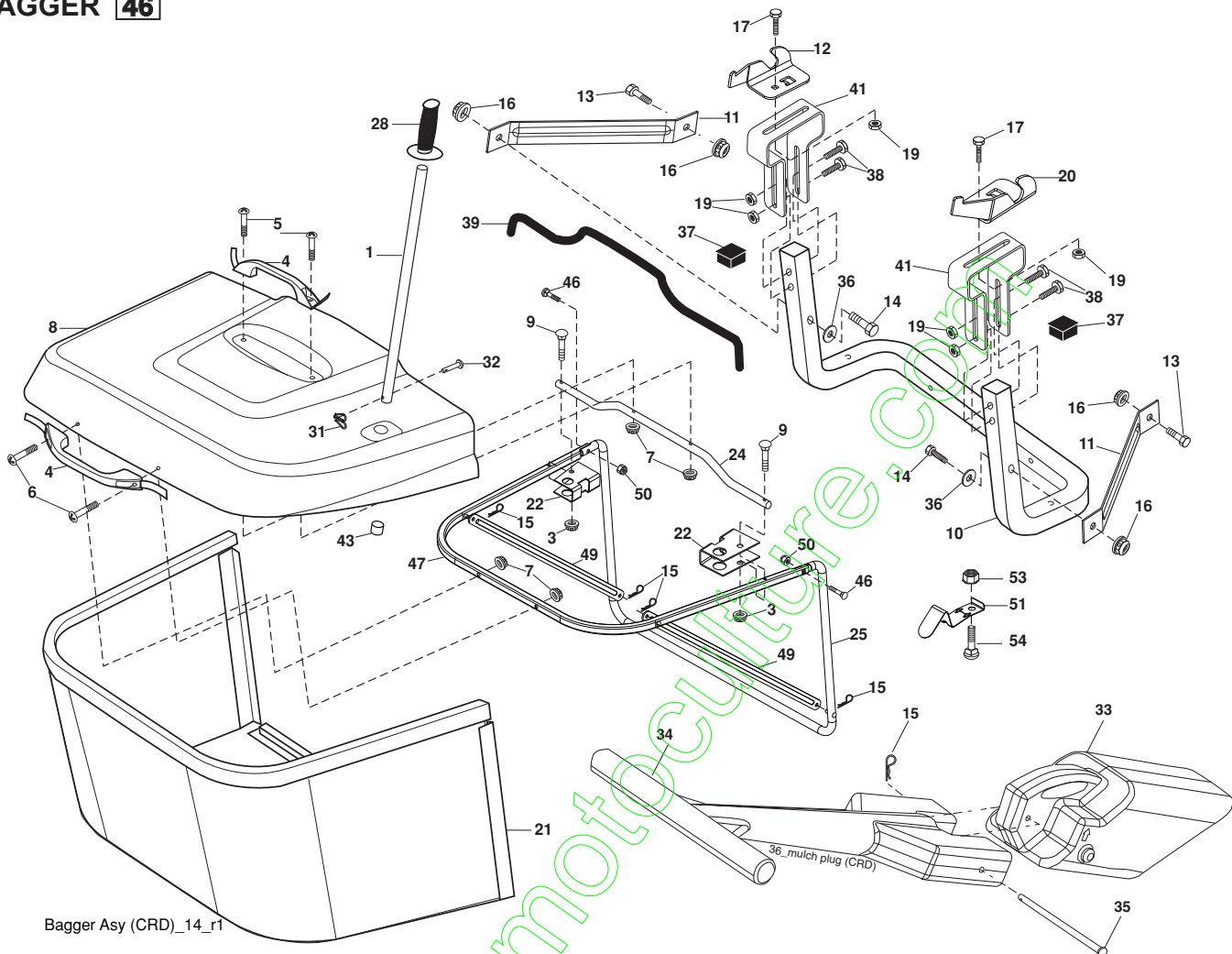

Bagger Asy (CRD)_14_r1

KEY NO.	PART NO.	DESCRIPTION	KEY NO.	PART NO.	DESCRIPTION
1	532 16 52-49	Tube Handle Bagger CRD	28	532 16 57-87	Grip Handle
3	532 12 39-76	Nut Lock 1/4 Lge Flg Gr. 5 Zinc	31	532 16 94-84	Retainer Clip
4	532 16 99-16	Handle Bagger w/Lvrs Blk CRD	32	532 12 68-75	Rivet Rd Hd Drilled 3/8 Dia
5	874 98 10-24	Screw Pan Head #10-24 x 1.50 Blk	33	532 16 55-71	Plug Mulcher
6	874 98 10-32	Screw Pan Hd	34	532 16 55-70	Handle Mulcher
7	873 40 10-00	Nut Wiz Lock Hex Serr/Hd 10-24	35	532 16 55-72	Pin Mulcher
8	532 18 10-95	Cover Bagger	36	819 13 20-12	Washer 13/32 x 1-1/4 x 12 Ga.
9	872 14 04-18	Bolt Carriage 1/4-20 x 2.25d x Gr. 5	37	532 17 54-01	Plug Support Bagger CRD
10	532 18 12-82	Tube Support Bagger CRD	38	872 01 05-20	Bolt 5/16-18 x 2-1/2
11	532 16 57-19	Bracket Support Upper Bag CRD	39	532 41 62-57	Seal
12	532 18 88-48	Bracket Pivot LH	41	532 16 96-83	Bracket Pnt Adj Pvt Bagger CRD
13	874 76 06-12	Bolt Fin Hex 3/8 -16 unc	43	532 17 40-83	Plug Tubing End
14	874 52 06-36	Bolt Fin Hex 3/8-16 x 2-1/4 Gr. 5	46	872 11 05-10	Bolt 5/16-18 x 1-1/4
15	532 12 46-70	Retainer Spring	47	532 19 37-04	Tube Upper Bagger
16	873 90 06-00	Nut Lock 3/8-16 unc	49	532 19 33-05	Bar Spreader Bagger CRD
17	872 14 05-06	Bolt Rdhd Sht Sqnk 5/16 -18 unc x 3/4	50	873 80 05-00	Nut 5/16-18
19	873 90 05-00	Nut Lock Hex Flange 5/16-18	51	532 19 99-03	Latch Spring Bagger
20	532 18 88-47	Bracket Pivot RH	53	873 51 04-00	Nut 1/4-20 unc
21	532 40 61-80	Bag Asm CRD	54	872 14 04-06	Bolt 1/4-20 x 3/4 Gr. 5
22	532 16 57-81	Bracket Side Bagger CRD			
24	532 16 57-83	Tube Pivot Bagger CRD			
25	532 19 37-05	Tube Front Bagger			

NOTE: All component dimensions given in U.S. inches
1 inch = 25.4 mm

www.emc-motoculture.com