

# CTH150

**Spare parts**

**Ersatzteile**

**Pièces détachées**

**Reserve onderdelen**

**Repuestos**

**Reservdelar**

[www.emc-motoculture.com](http://www.emc-motoculture.com)



# REPAIR PARTS

TRACTOR- -MODEL NO. CTH150 (HECTH150B), PRODUCT NO. 954 17 00-38  
ELECTRICAL

KEY NO.	PART NO.	DESCRIPTION
1	532144925	Battery 12 Volt 25 AMP Wet
2	874760412	Bolt Hex Hd 1/4-20 Unc X 3/4
16	532153664	Switch Interlock Push-In
21	532166181	Harness Asm Light W/4152J
22	532004152	Bulb Light #1156
24	532124780	Cable Starter 6Ga 11" Red
25	532165987	Cable Battery Crd 56" Red
26	532175158	Fuse
27	873510400	Nut Keps Hex 1/4-20 Unc
28	532127725	Cable Ground 6Ga 18" Black
29	532160784	Switch Plunger Normal Op Olive
30	532175566	Switch Ignition
33	532140401	Key Ign
40	532170214	Harness Ign
41	871110408	Bolt Flk Fin Hex 1/4-20 Unc X 1/2
42	532131563	Cover Terminal Red
43	532175141	Solenoid
48	532140844	Adapter Ammeter Rectangular
50	532174651	Switch PTO
51	532140405	Ring Retainer PTO
52	532141940	Protection Wire Loop
58	532169419	Buzzer Crd
59	532166299	Switch FBI CRD
65	817211008	Screw Slftp #10-16 x 1/2 Ty-Ab
66	817490608	Screw Thdrol 3/8-16 x 1/2 Ty-Tt
80	532146685	Harness Clutch EVX
81	532109748	Relay Asm

**NOTE:** All component dimensions given in U.S. inches.  
1 inch = 25.4 mm.

# REPAIR PARTS

TRACTOR- -MODEL NO. CTH150 (HECTH150B), PRODUCT NO. 954 17 00-38  
CHASSIS AND ENCLOSURES

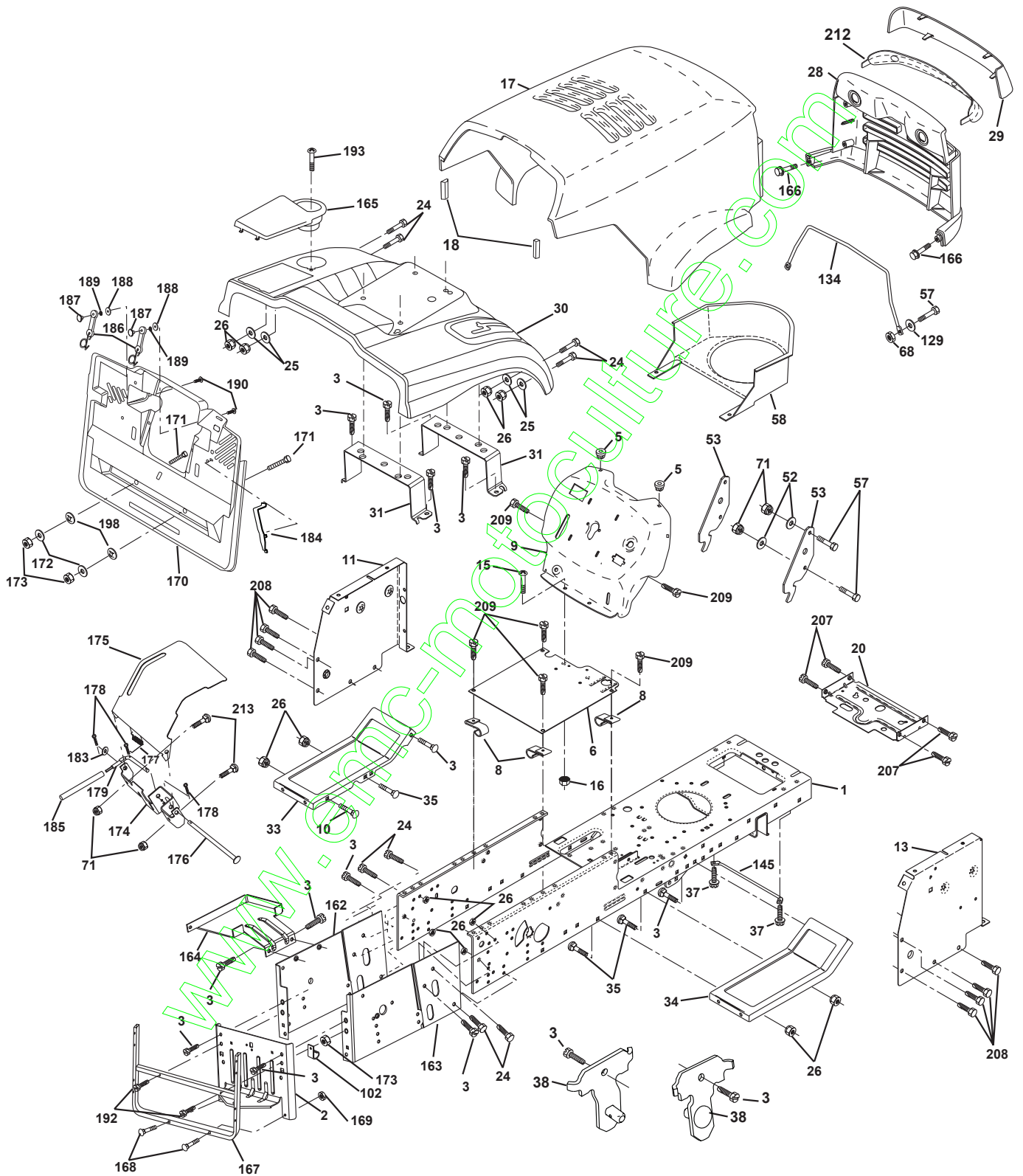

# REPAIR PARTS

## TRACTOR- -MODEL NO. CTH150 (HECTH150B), PRODUCT NO. 954 17 00-38 CHASSIS AND ENCLOSURES

KEY NO.	PART NO.	DESCRIPTION	KEY NO.	PART NO.	DESCRIPTION
1	532169831	Chassis Assembly	162	532170256	Bracket Exten Chassis Lh CRD
2	532165606	Drawbar	163	532175770	Bracket Exten Chassis Rh CRD
3	817060612	Screw 3/8-16 x 3/4	164	532165605	Support Battery CRD
5	532155272	Bumper Hood/Dash	165	532167979	Cover Battery CRD Lt
6	532155923	Saddle	166	532164863	Screw Hwhd Hi-Lo #13-16 x 3/4
8	532126471	Clip Insulator 13/32 Mtg. Hole	167	532165779	Support Asm. Backplate WLDMNT
9	532171191	Dash	168	872050412	Bolt, RDHD SHT NK 1/4-20 x 1-1/2
10	872140608	Bolt, Carriage 3/8-16 x 3/4	169	532123976	Nut, Lock 1/4 LGE FLG Gr. 5 Zinc
11	532155927	Panel, Dash, L.H.	170	532175264	Backplate Asm CRD
13	532172108	Panel, Asm. Dash R.H.	171	872140620	Bolt Hex 3/8-16 x 2-1/2 Gr 5
15	874180512	Screw, Machine, Truss Head 5/16-18 UNC x 3/4	172	819132016	Washer 13/32 x 1-1/4 x 16 Ga.
16	873510500	Nut	173	873510600	Nut, Keps Hex 3/8-16 UNC
17	532165378	Hood Assembly	174	532165939	Bracket Switch FBI CRD
18	532126938	Bumper Hood	175	532166212	Guard Door Rear CRD
20	532156437	Plate Mtg. Battery/Fuel Tank	176	532128600	Pin Hinge Pivot
24	874780616	Bolt	177	532132796	Spring Bagger Top LH Black
25	819131312	Washer 13/32 x 13/16 x 12 Gauge	178	876020312	Pin Cotter 3/32 x 3/4 Cad Zinc
26	873800600	Nut	179	532165942	Rod Pivot FBI CRD
28	532165379	Grille PL	183	819131316	Washer 13/32 x 13/16 x 16 Ga.
29	532165380	Lens, Grille	184	532174662	Bracket Actuator Bagger CRD
30	532175791	Fender	185	532165940	Tube Lever Switch FBI CRD
31	532165156	Bracket, Fender Support	186	532160793	Latch Asm Multch Bagger
33	532147203	Footrest, L.H.	187	532125004	Nut Weld .327/.304 #10-24
34	532147202	Footrest, R.H.	188	819061216	Washer #10
35	872110606	Bolt	189	810071000	Washer Lock #10
37	817490508	Screw Thdrol 5/16-18 x 1/2 TYT	190	871081010	Screw Pan Hd Phillip 10-24 x 5/8
38	532169834	Bracket Asm. Pivot Mower Rear	192	<b>817060624</b>	Screw Thdrol 3/8-16 x 1-1/2
52	819091416	Washer 9/32 x 7/8 x 16 Ga.	193	817070412	Screw Truss 1/4-20 x 3/4 Tap/R
53	532150067	Bracket Pick off Lt/PI Husq	198	532168937	Nut Push
57	874780412	Bolt, Fin Hex 1/4-20 UNC x .75	207	817670508	Screw Thdrol 5/16-18 x 1/2 Tytt
58	532150127	Duct Intake Engine	208	817670608	Screw Thdrol 3/8-16 x 1/2
68	873510400	Nut Keps Hex 1/4-20 Unc	209	817000612	Screw Hex Wsh Thdrol 3/8-16 BL
71	873680400	Nut Crownlock 1/4-20 Unc	212	532156195	Insert lens Reflective
102	532124996	Clip Fuel Line 13/32 Mtg Hole	213	<b>872110406</b>	Bolt Carr
129	819091016	Washer 9/32 x 5/8 x 16 Ga.	--	532005479	Plug Button
134	532160219	Rod Support Hood Husq P/L			
145	532156524	Rod Pivot Chassis/Hood			

**NOTE:** All component dimensions given in U.S. inches.  
1 inch = 25.4 mm.

# REPAIR PARTS

TRACTOR- -MODEL NO. CTH150 (HECTH150B), PRODUCT NO. 954 17 00-38  
DRIVE

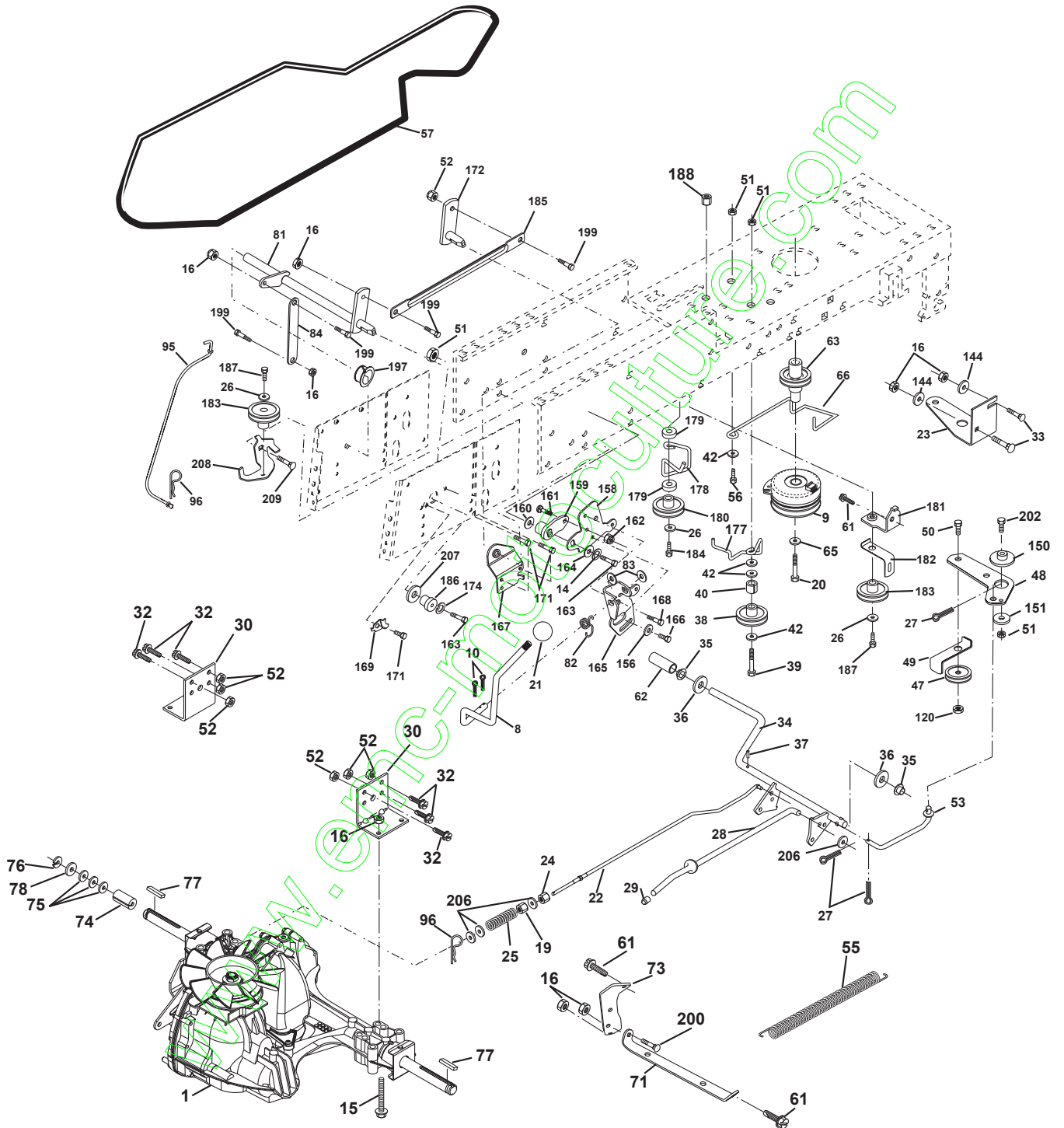



# REPAIR PARTS

TRACTOR- -MODEL NO. CTH150 (HECTH150B), PRODUCT NO. 954 17 00-38  
DRIVE

KEY NO.	PART NO.	DESCRIPTION	KEY NO.	PART NO.	DESCRIPTION
1	-----	Transaxle Hydro Gear 321-0510 (Order parts from transaxle manufacturer)	77	532123583	Key, Square
8	532165619	Rod, Shift Fender Adjust Lt	78	532121748	Washer 25/32 x 1-5/8 x 16 Ga.
9	532167162	Clutch Ele EVX	81	532170006	Asm, Shaft
10	876020416	Pin, Cotter 1/8 x 1	82	532123782	Spring, Torsion
14	810040400	Washer, Lock Hvy Helical	83	819171216	Washer 17/32 x 3/4 x 16 Ga.
15	874490544	Bolt Hex FLGHD 5/16-18 Gr. 5	84	532170007	Link, Transaxle
16	873800500	Nut, Lock Hex w/Ins 5/16-18 UNC	95	532170015	Control Asm Bypass Hydro
19	873800600	Nut Lock Hex W/Ins 3/8-16	96	532124788	Spring, Retainer 1"
20	532150280	Bolt Hex 7/16-20 x 4-1/4	120	873900600	Nut Lock Flg 3/8-16 UNC
21	532121274	Knob Duckhead 1/4-13 Unc Blk	144	819111016	Washer 11/32 x 5/8 x 16 Ga.
22	532170137	Rod, Brake	150	532165850	Bushing, Bellcrank Grnd Dr
23	532171258	Bracket asm Clutch Mtg.	151	819133210	Washer 13/32 x 2 x 10 Ga.
24	873350600	Nut	156	532166002	Washer Srrted 5/16ID x 1.125
25	532106888	Spring, Rod, Brake	158	532165589	Bracket Shift Mount
26	819131316	Washer 13/32 x 13/16 x 16 Ga.	159	532165494	Hub Tapered Flange Shift Lt
27	876020412	Pin, Cotter 1/8 x 3/4	160	819292016	Washer 29/32 x 1-1/4 x 16 Ga.
28	532145204	Rod, Parking Brake	161	872140406	Bolt Rdhd Sqnk 1/4-20 x 3/4 Gr 5
29	532071673	Cap, Parking Brake	162	873680400	Nut Crownlock 1/4-20 Unc
30	532169592	Bracket, Mfg. Transaxle	163	874780416	Bolt Hex Fin 1/4-20 Unc x 1 Gr 5
32	874760512	Bolt Hex 5/16-18 UNC x 3/4	164	819091010	Washer 5/8 x .281 x 10 Ga.
33	872140506	Bolt Rdhd Sqnk 5/16-18 Unc x 3/4	165	532165623	Bracket Pivot Lever
34	532165496	Shaft, Asm Pedal Foot CRD	166	532166880	Screw 5/16-18 x 5/8
35	532120183	Bearing, Nylon	167	532165588	Bracket Support Shift CRD
36	819211616	Washer 21/32 x 1 x 16 Ga.	168	532165492	Bolt Shoulder 5/16-18 x .561
37	532124963	Pin, Roll 3/16 x 1"	169	532165580	Plate Fastening Lt
38	532165936	Pulley Flat Composite 3.06"	171	817490608	Screw Thdrol 3/8-16 x 1/2 Ty-Tt
39	874760644	Bolt Fin Hex 3/8-16 Unc x 2-3/4	172	532170271	Shaft Asm Shifter Frt
40	532124965	Spacer, Split 395 x 59 Bzp	174	810090400	Washer Lock 1/4
42	819131312	Washer 13/32 x 13/16 x 12 Ga.	177	532165932	Keeper Flat Idler 3.06" CRD
47	532127783	Pulley, Idler, V Groove Plasic	178	532165933	Keeper Belt Idler 1.88" CRD
48	532154407	Bellcrank Clutch Grnd Dry	179	532120958	Washer Sintered
49	532123205	Retainer, Belt Style Spring	180	532165630	Pulley, Idler, Flat 1.88"CRD
50	874760624	Bolt Hex Hd 3/8-16 UNC x 1-1/2	181	532165797	Bracket Idler Ground Drive CRD
51	873680600	Nut, Crownlock 3/8-16 UNC	182	532165634	Keeper Belt 2.5" Od V-Idler CRD
52	873680500	Nut Crownlock 5/16-18	183	532165626	Pulley V-Idler 2.50" Od CRD
53	532105710	Link, Clutch 7.66	184	817490644	Screw Hexwsh Thdrol 3/8-16 x 2-3/4
55	532105709	Spring, Return, Clutch	185	532170008	Link Shift CRD Hydro
56	874760620	Bolt, Hex 3/8-16 UNC x 1-1/4	186	532165614	Hub Tapered Round CRD
57	532170140	V-Belt Key 113"	187	817060620	Screw 3/8-16 x 1-1/4
61	817060612	Screw 3/8-16 x 3/4	188	532110436	Bushing Snap Split Blk
62	532123533	Cover, Pedal	197	532169613	Nyliner Snap-In 5/8" ID
63	532145868	Pulley, Clutch elect EVX 1"	199	532169612	Bolt Shoulder 5/16-18 UNC
65	810040700	Washer	200	872140508	Bolt RDHD SQNK 5/16-18unc x 1
66	532154778	Keeper, Belt Engine F-Proof	202	872110612	Bolt Carr. Sh. 3/8-16 x 1-1/2 Gr. 5
71	532169183	Strap, Torque, Lh	206	819131416	Washer 13/32 x 7/8 x 16 Ga.
73	532169182	Strap, Torque, Rh	207	532169845	Washer Nylon Rear
74	532137057	Spacer	208	532169844	Bracket Idler Rear LH
75	532121749	Washer 25/32 x 1-1/4 x 16 Ga.	209	872110606	Bolt RDHD SQNK 3/8-16 x 3/4
76	812000001	Ring, E			

**NOTE:** All component dimensions given in U.S. inches  
1 inch = 25.4 mm





# REPAIR PARTS

TRACTOR- -MODEL NO. CTH150 (HECTH150B), PRODUCT NO. 954 17 00-38  
STEERING ASSEMBLY

KEY NO.	PART NO.	DESCRIPTION
1	532166627	Steering Wheel
2	532172393	Front Axle Assembly
3	532169840	Spindle Assembly, L.H.
4	532169839	Spindle Assembly, R.H.
5	532124931	Bearing, Race, Thrust, Hardened
6	532121748	Washer 25/32 x 1-5/8 x 16 Gauge
8	812000029	Ring, Klip
10	532169832	Link, Drag
11	810040600	Washer, Lock
13	532136518	Spacer Axle
15	532145212	Nut Hex Flange Lock
17	532156546	Shaft Assembly, Steering
18	532057079	Washer, Thrust .515 x .750 x .033
19	532160395	Support, Shaft
22	532165857	Screw Hex Wshhd Torx
23	532165851	Pittman Shaft Assembly
25	532154406	Bracket, Steering
27	532136874	Gear, Sector
29	817060612	Screw 3/8-16 x 3/4
32	532171888	Rod, Tie
33	819111216	Washer 11/32 x 3/4 x 16 Ga.
34	810040500	Washer, Lock Hvy Hlcl Spr 5/16
35	873540500	Crownlock Nut 5/16-24 Unf
36	532155099	Bushing, Steering
37	532152927	Screw TT #10-32 x 5 x 3/8 Flange
38	532166626	Cap Wheel Steer
39	819132411	Washer 13/32 x 1-1/20 x 11 Gauge
40	532124701	Nut Lock Center 3/8-24 Unf
41	532159945	Adaptor, Steering Wheel
42	532169634	Boot, Steering Dash P/L Mtl
43	532121749	Washer 25/32 x 1-1/4 x 16 Gauge
44	532153720	Extension Steering Non-Adjust
46	532121232	Cap, Spindle
51	873800500	Nut Lock Hx W/Ins 5/16-18 UNC
54	874780520	Bolt Fin Hex 5/16-18 UNC x 1-1/4
62	<b>532167902</b>	Kit, Steering Assembly, Service
63	874780616	Bolt Fin Hex 3/8-16 unc. x 1 Gr. 5
65	532160367	Spacer Axle
66	532154404	Bearing Arm Pittman
67	872140618	Bolt Rdhd Sq 3/8-16 x 2-1/4
68	532169827	Brace Axle
79	819132012	Washer 13/32 x 1-1/4 x 12 Ga
80	874950612	Bolt Hex Nylon 3/8-16 x 3/4
82	532169835	Bracket Susp. Chassis Front
87	532173966	Washer Flat .781 x 1-1/2 x .14

**NOTE:** All component dimensions given in U.S. inches.  
1 inch = 25.4 mm.

# REPAIR PARTS

TRACTOR- -MODEL NO. CTH150 (HECTH150B), PRODUCT NO. 954 17 00-38  
SEAT ASSEMBLY

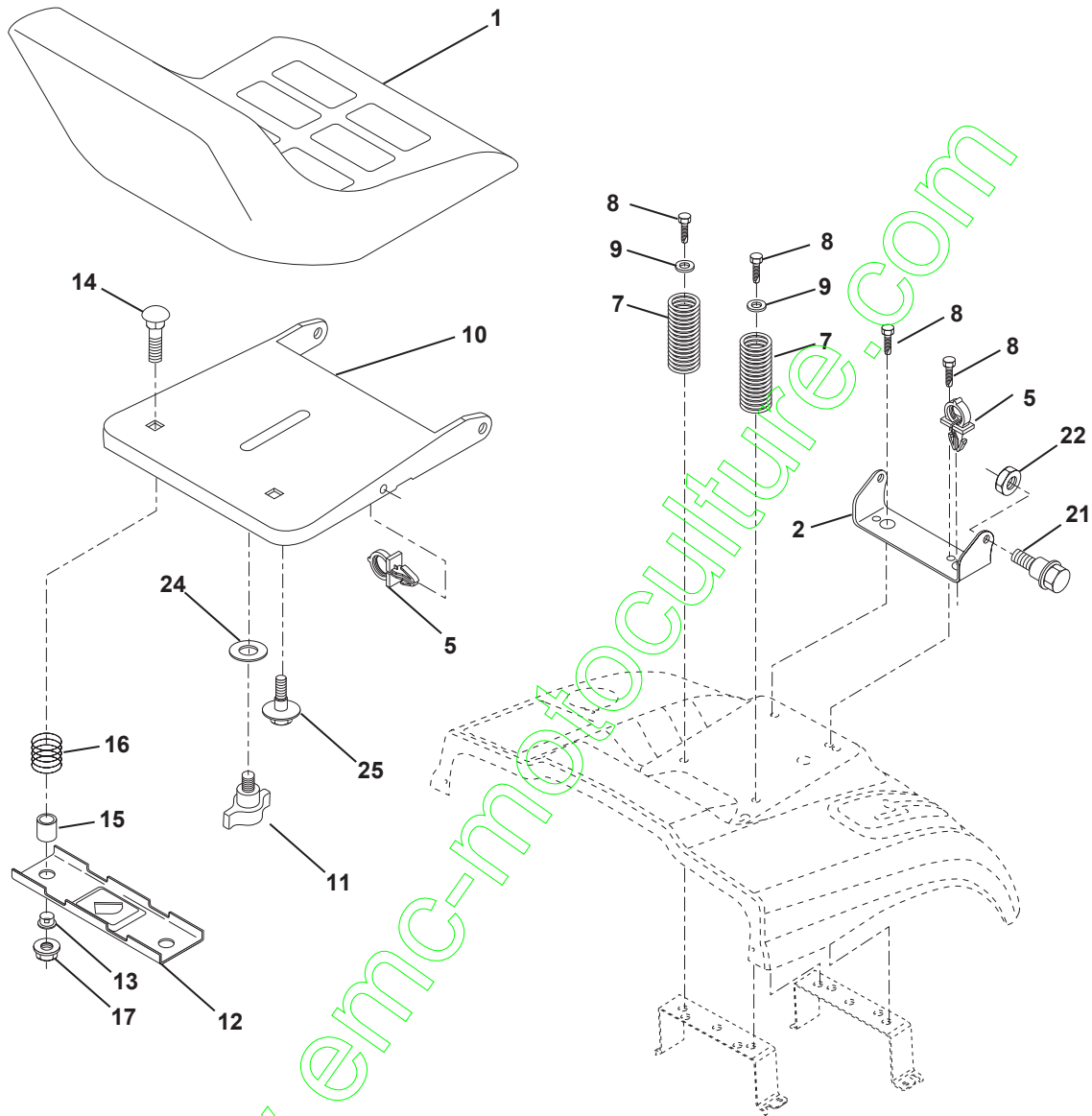

KEY NO.	PART NO.	DESCRIPTION
1	532140840	Seat
2	532140551	Bracket Pnt Pivot Seat (blk )
5	532145006	Clip Push In Hinged
7	532124181	Spring Seat Cprsn 2 250 Blk Zi
8	817000616	Screw 3/8-16 X 1.5
9	819131614	Washer 13/32 X 1 X 14 Ga
10	532174894	Pan Pnt Seat (blk )
11	532166369	Knob Seat Adj. Wingnut
12	532121246	Bracket Pnt Mounting Switch
13	532121248	Bushing Snap Blk Nyl 50 Id

KEY NO.	PART NO.	DESCRIPTION
14	872050412	Bolt Rdhd Sht Nk 1/4-20x1-1/2
15	532121249	Spacer Split
16	532123740	Spring Cprsn
17	532123976	Nut Lock 1/4 Lge Flg Gr 5 Zinc
21	532171852	Bolt Shoulder 5/16-18 Unc-2A
22	873800500	Nut Hex Lock w/Ins 5/16-18
24	819171912	Washer 17/32 X 1-3/16 X 12 Ga.
25	532127018	Bolt Shoulder 5/16-18 X 62

**NOTE:** All component dimensions given in U.S. inches.  
1 inch = 25.4 mm

# REPAIR PARTS

TRACTOR- -MODEL NO. CTH150 (HECTH150B), PRODUCT NO. 954 17 00-38  
DECALS

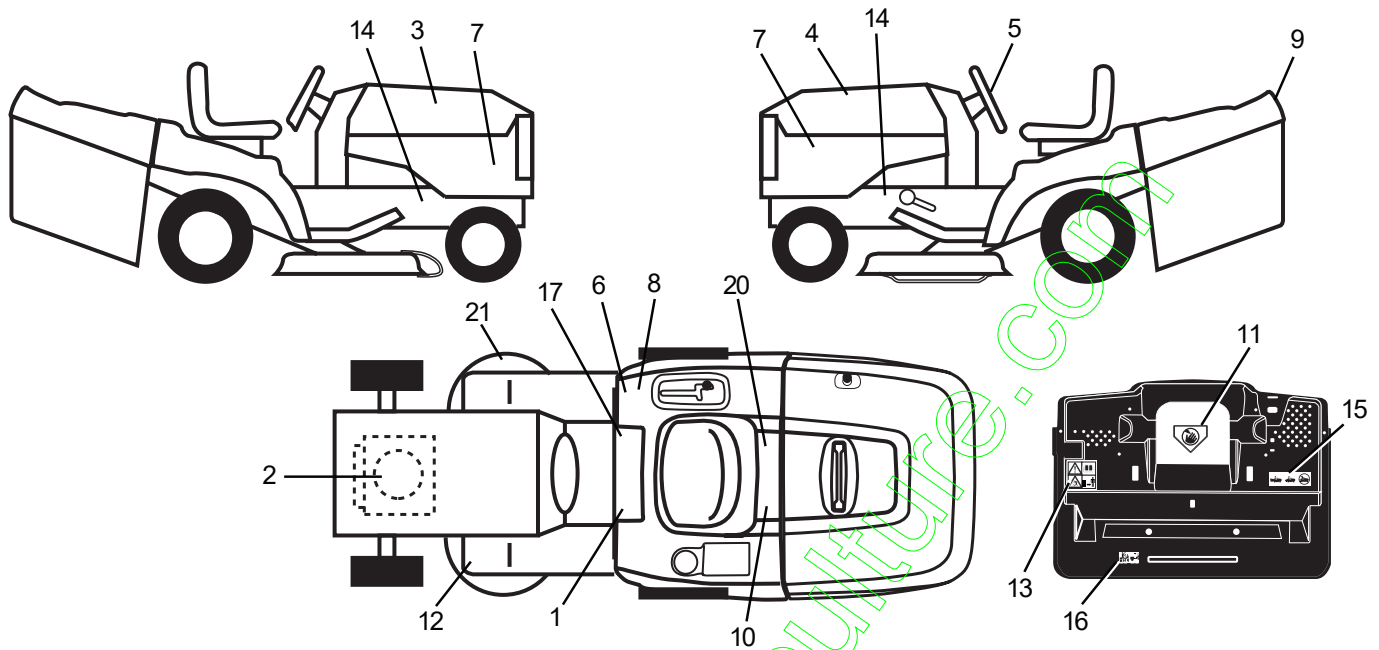

KEY NO.	PART NO.	DESCRIPTION	KEY NO.	PART NO.	DESCRIPTION
1	532145498	Decal Read Owner's Manual Sym	12	532159737	Decal Brake/Clutch Symbol Lt
2	<b>532176400</b>	Decal Hp Engine	13	532166959	Decal Warn Back Plate CRD
3	532170596	Decal Hood Rh	14	532159736	Decal Chassis Hot Muffler
4	532170597	Decal Hood Lh	15	532166961	Decal Oper Bag Presence CRD
5	532170564	Decal Wheel Steering	16	532162598	Decal Drawbar Load Limit
6	532126187	Decal 100 DBA	17	532140837	Decal Saddle Brake Parking
7	532159713	Decal Panel Side B&S Logo	20	532166960	Decal Bypass Fender CRD
8	532145437	Decal Europe Stand Ce	21	532166286	Decal Hex Belt Sch 92 CRD
9	532150617	Decal Fender Logo	—	532138311	Decal Lift Handle
10	532145005	Decal Bat Dan/Poi P/L Sym Wpn	—	532171237	Pad Footrest
11	532145494	Decal Mower Cut Finger Symbol	—	532176219	Manual Operator's (Euro)
			—	532176220	Manual Operator's (Scan)

## WHEELS & TIRES

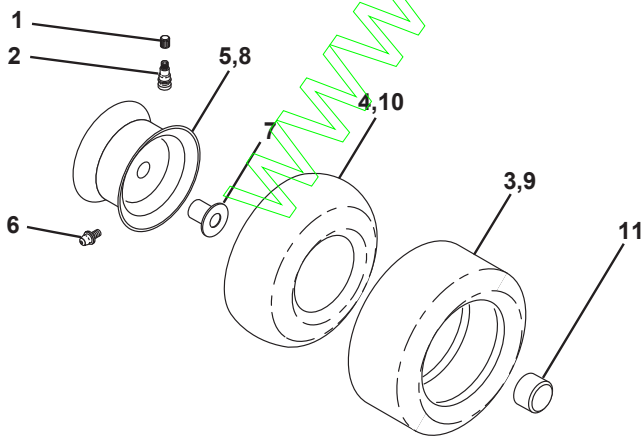

KEY NO.	PART NO.	DESCRIPTION
1	532059192	Cap Value Tire
2	532065139	Stem Value
3	532106222	Tire F Ts 15 X 6 0 - 6 Service
4	532059904	Tube Inner Front #35060
5	532138336	Rim Asm 6"front Silver Service
6	532124957	Fitting Grease
7	532124959	Bearing Flange
8	532138337	Rim Asm 8"rear Silver Service
9	532138468	Tire R Ts 20 x 8-8 Service
10	532124926	Tube Rear 9 5 X 8 Service
11	532175039	Cap Axle Blk 1 50 X 1 00
--	144334	Sealant, Tire (10 oz. tube)

**NOTE:** All component dimensions given in U.S. inches  
1 inch = 25.4 mm

# REPAIR PARTS

TRACTOR- -MODEL NO. CTH150 (HECTH150B), PRODUCT NO. 954 17 00-38  
ENGINE

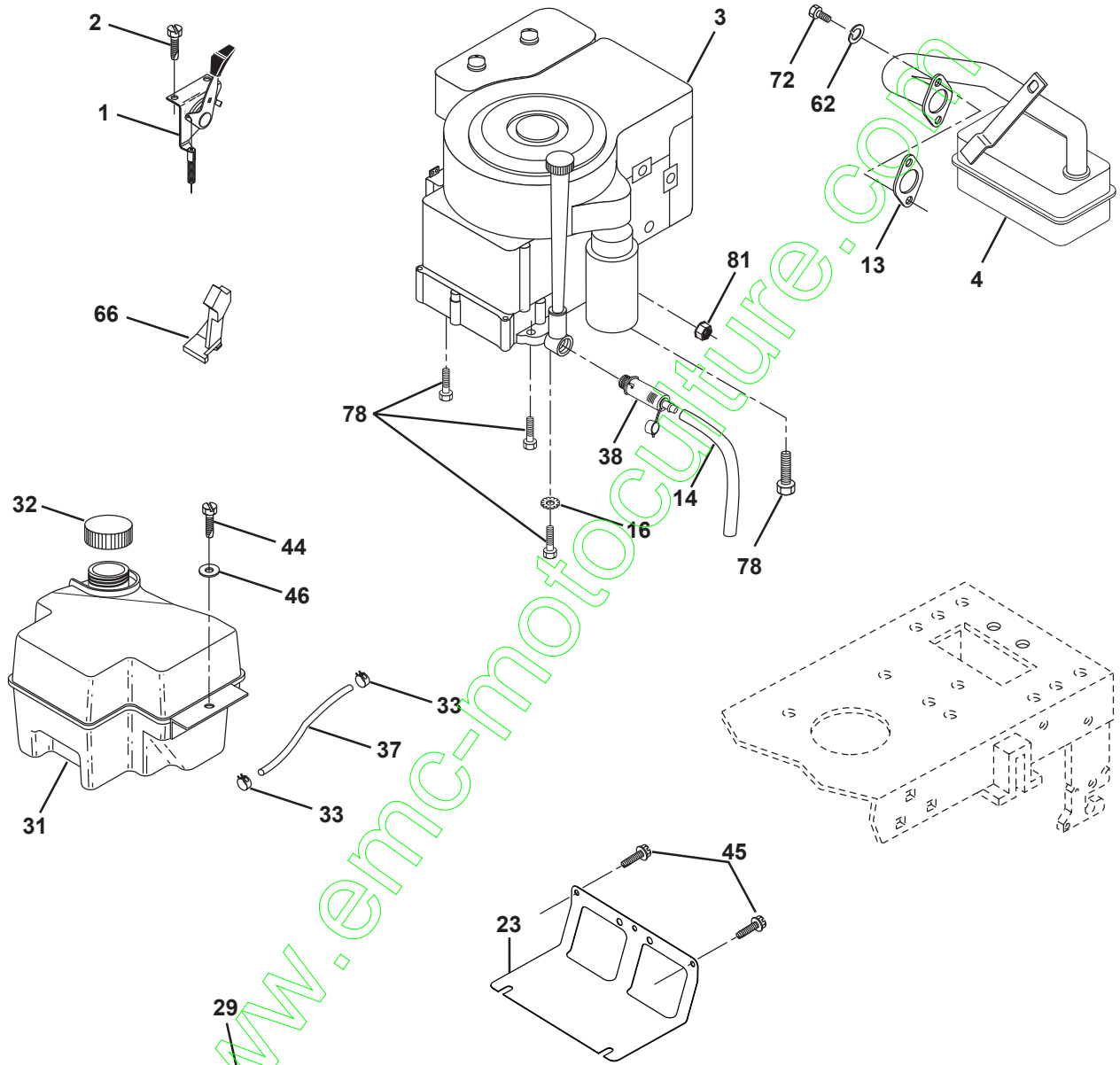

**OPTIONAL EQUIPMENT**  
**Spark Arrester**

# REPAIR PARTS

TRACTOR- -MODEL NO. CTH150 (HECTH150B), PRODUCT NO. 954 17 00-38  
ENGINE

KEY NO.	PART NO.	DESCRIPTION
1	532170865	Control Throt/Ck
2	817720410	Screw Hex Thd Cut 1/4-20x5/8 T
3	-----	Engine B&S Model 311777 (Order parts from engine manufacturer)
4	532137352	Muffler
13	532165291	Gasket Muffler
14	532148456	Tube Drain Oil Easy
16	811050600	Washer Lock Ext Tooth 3/8
23	532169837	Shield Brn/Dbr Guard
29	532137180	Kit Spark Arrestor (Flat Scrn)
31	<b>532174642</b>	Tank Fuel 2.00
32	532140527	Cap Asm Fuel W/sym Vented
33	532123487	Clamp Hose Blk
37	532137040	Line Fuel
38	532148315	Plug Drain Oil Easy
44	817670412	Screw Hexwsh thdrol 1/4-20 x 3/4
45	817000612	Screw Hexwsh Thdr 3/8-16 x 3/4
46	819091416	Washer 9/32 x 7/8 x 16 Ga.
62	810040500	Washer, Lock Hvy. Hlcl Spr 5/16
66	532127951	Stop Throttle
72	871070512	Screw Hex Hd Cap 5/16-18 x 3/4
78	817060620	Screw 3/8-16 x 1/4
81	873510400	Nut Keps Hex 1/4-20 Unc

**NOTE:** All component dimensions given in U.S. inches  
1 inch = 25.4 mm

www.emc-machinery.com

# REPAIR PARTS

TRACTOR- -MODEL NO. CTH150 (HECTH150B), PRODUCT NO. 954 17 00-38  
MOWER LIFT

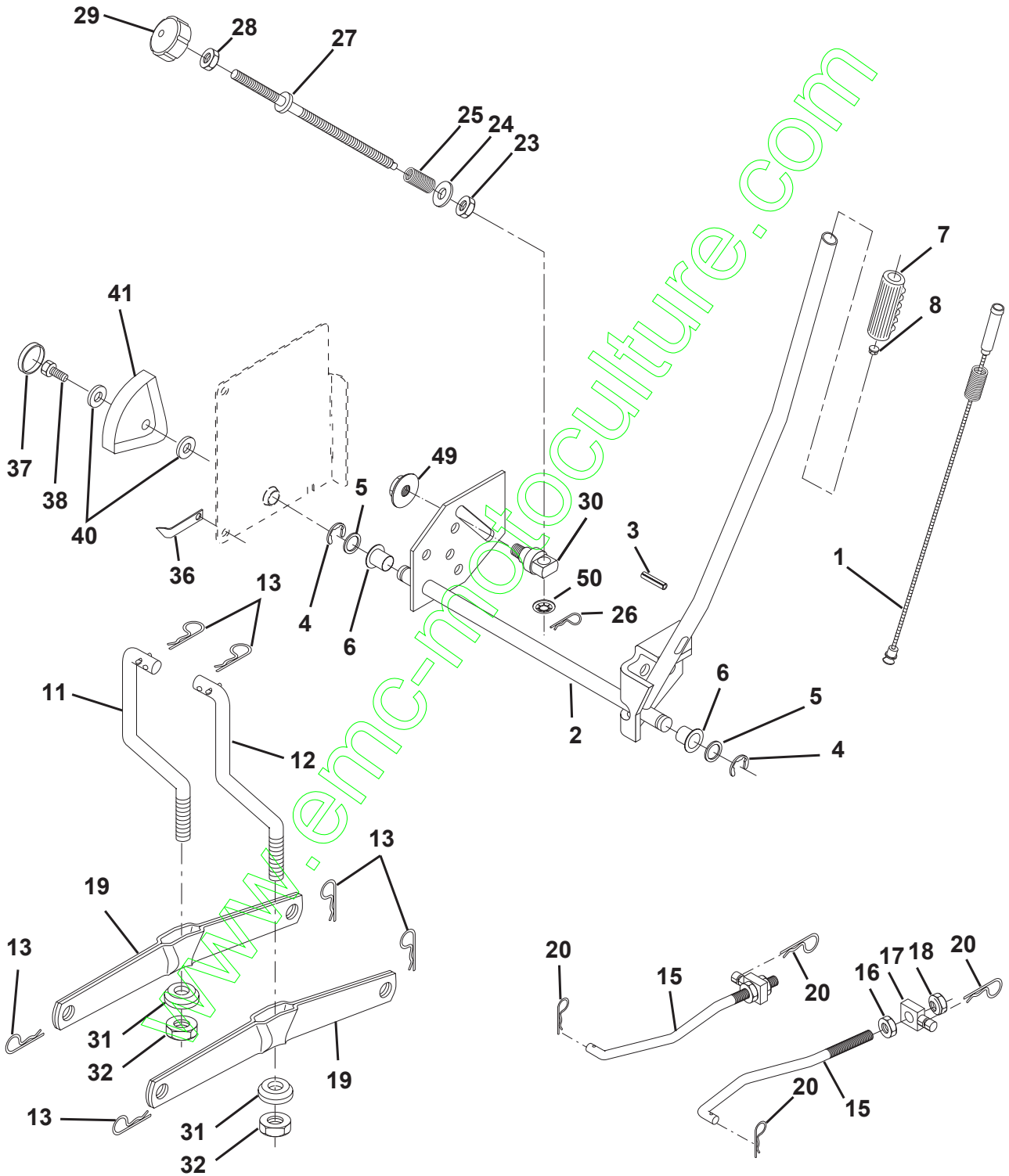



# REPAIR PARTS

TRACTOR- -MODEL NO. CTH150 (HECTH150B), PRODUCT NO. 954 17 00-38  
MOWER LIFT

KEY NO.	PART NO.	DESCRIPTION
1	532159460	Washer Asm Inner Spring W/Plunger
2	532159471	Shaft Asm. Lift
3	532105767	Pin Groove
4	812000002	E Ring #5133-62
5	819211621	Washer 21/32 x 1 x 21 Ga.
6	532120183	Bearing Nylon
7	532125631	Grip Handle Fluted
8	532124526	Button Plunger Black
11	532165829	Link Asm Lift L.H.
12	532165831	Link Asm Lift R.H.
13	532124670	Retainer Spring
15	532173288	Link Front
16	873350800	Nut Jam Hex 1/2-13 Unc
17	532130171	Trunnion Blk Zinc
18	873800800	Nut Lock w/wsh 1/2-13 Unc
19	532139868	Arm Suspension Mower
20	532163552	Retainer Spring
23	532110807	Nut Special
24	819131016	Washer 13/32 x 5/8 x 16 Ga.
25	532124874	Spring 2-1/8"
26	532169484	Retainer Clip
27	532126971	Rod Adj Lift Zinc 7.49 Wrk Lg
28	873350600	Nut Hex Jam 3/8-16 Unc
29	532138057	Knob Inf 3/8-16 Unc Blk w/sym
30	532150233	Trunnion Infn Height
31	532169865	Bearing, Pvt. Lift.
32	873540600	Nut Crownlock 3/8-24
36	532155097	Pointer Height Indicator
37	532123935	Plug Hole Blk 1.485/1.515 Dia
38	817060516	Screw 5/16-18 x 1
40	819112410	Washer 11/32 x 1-1/2 x 10 Ga.
41	532123934	Scale Ind Height Blk
49	532145212	Nut hex Flange Lock
50	532110452	Nut Push Phos & Oil

**NOTE:** All component dimensions given in U.S. inches  
1 inch = 25.4 mm

# REPAIR PARTS

TRACTOR- -MODEL NO. CTH150 (HECTH150B), PRODUCT NO. 954 17 00-38  
MOWER

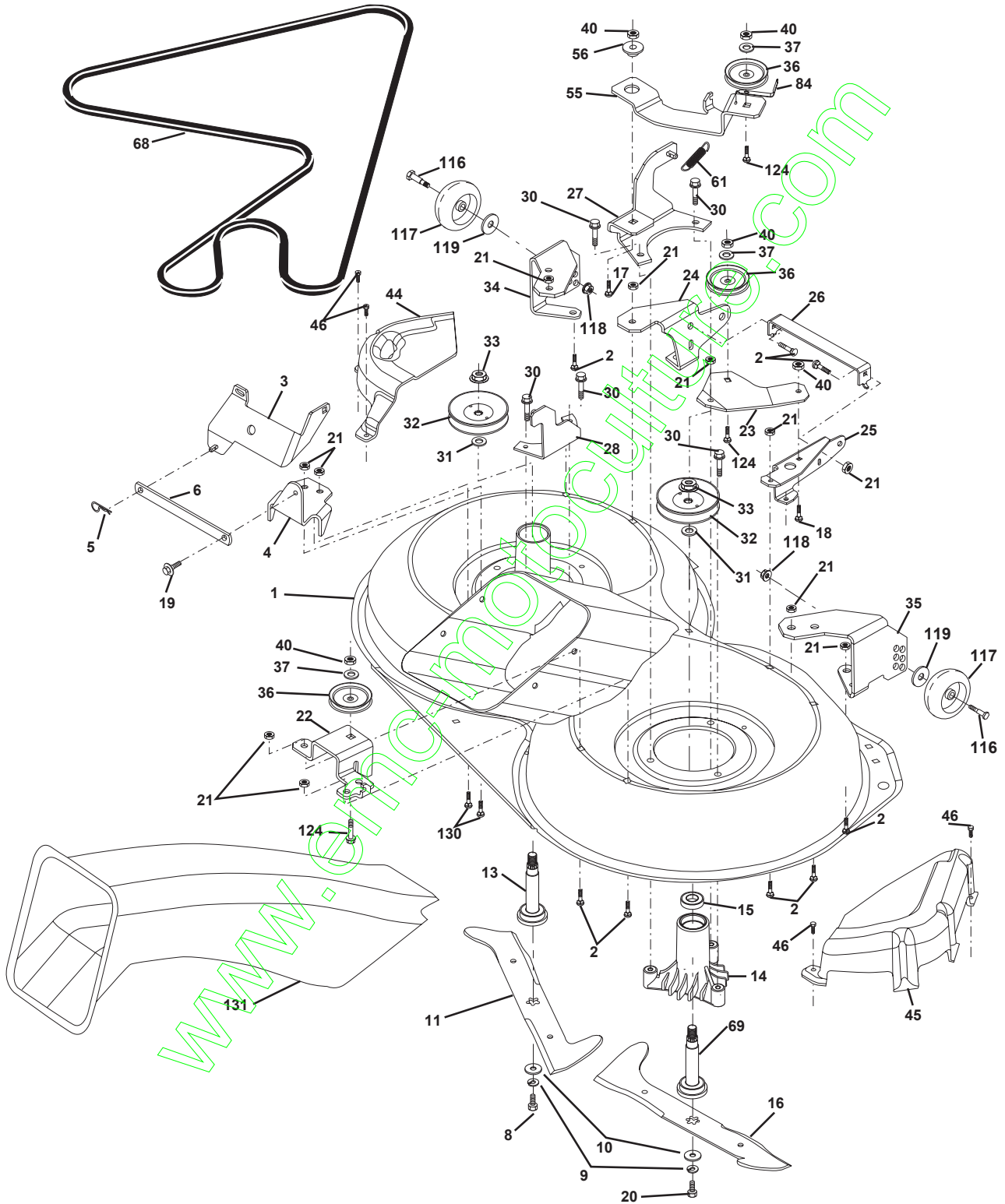

# REPAIR PARTS

TRACTOR- -MODEL NO. CTH150 (HECTH150B), PRODUCT NO. 954 17 00-38  
MOWER

KEY NO.	PART NO.	DESCRIPTION	KEY NO.	PART NO.	DESCRIPTION
1	532165552	Housing Asm. Mower	33	532137266	Nut Flg Top Lock Cntr B 9/16
2	872140506	Bolt Rdhd Sqnk 5/16-18 Unc x 3/4	34	532165239	Bracket Gauge Wheel Lf
3	532165569	Bracket Asm. S-Bar Chass	35	532165238	Bracket Gauge Wheel Rf
4	532165558	Bracket Bar Sway Deck	36	532146763	Pulley Idler V-Groove Dim 4.25
5	532124670	Retainer Spring	37	819131316	Washer 11/32 x 13/16 x 16 Ga
6	532165557	Bar Sway	40	873680600	Nut Crownlock 3/8-16 Unc
8	532850857	Bolt 3/8-24 x 1.25 Gr8 Patched	44	532165724	Cover Mandrel Lh
9	810030600	Washer Lock Hvy 3/8 Unplated	45	532165556	Cover Mandrel Rh
10	532140296	Washer Hard Blade Mower vented	46	532137729	Screw Thd Roll 1/4-20 x 5/8
11	532170037	Blade 3-1 Lh	55	532165445	Arm Idler
13	532137645	Shaft Asm. W/Lower Bearing	56	532165723	Spacer Retainer Mower
14	532128774	Housing Mandrel Vented (Machd)	61	532165945	Spring Tension Belt
15	532110485	Bearing Ball Mandrel	68	532165555	Hex-Belt
16	532170038	Blade 3-1 Rh	69	532165482	Shaft Asm W/Lwr Brg Rh Thd CRD
17	872140610	Bolt Carriage 3/8-16 x 1-1/4	84	532156085	Keeper Belt Idler
18	872110608	Bolt Rdhd Sqnk 3/8-16 x 1 Gr5	116	532137644	Bolt Shoulder
19	532132827	Bolt Shoulder 5/16-18 Thd Form	117	532133957	Wheel Gage Donut Wide
20	532165484	Bolt 3/8-24 x 1.25 Gr8 Ptch Lhthd	118	873930600	Nut Centerlock 3/8-16 Unc
21	873680500	Nut Crown Lock 5/16-18	119	819121414	Washer 3/8 x 7/8 x 14 Ga.
22	532165243	Bracket Idler Sprt RR	124	872110612	Bolt Carr Sh 3/8-16 x 1-1/2 Gr5
23	532165446	Bracket Idler Sprt RF	130	872110506	Bolt Rdhdsqnk 5/16-18 Unc x 3/4
24	532165242	Bracket Suspension LF	131	532165661	Chute Bagger CRD 92cm
25	532165244	Bracket Suspension RF	-	532130794	Mandrel Asm Service
26	532165237	Brace Support Susp Frt	-	532165579	Mandrel Asm CRD Lh Threads SVC
27	532165568	Bracket Asm. Susp RR	-	532173549	Deck Mower Complete
28	532165567	Bracket Asm. Susp LR			
30	532157722	Screw Thd Rolling Washer Head			
31	532129963	Washer Spacer Mower Vented			
32	532153531	Mandrel Pulleys			

**NOTE:** All component dimensions given in U.S. inches  
1 inch = 25.4 mm

www.emc-motors.com

# REPAIR PARTS

TRACTOR- -MODEL NO. CTH150 (HECTH150B), PRODUCT NO. 954 17 00-38  
BAGGER

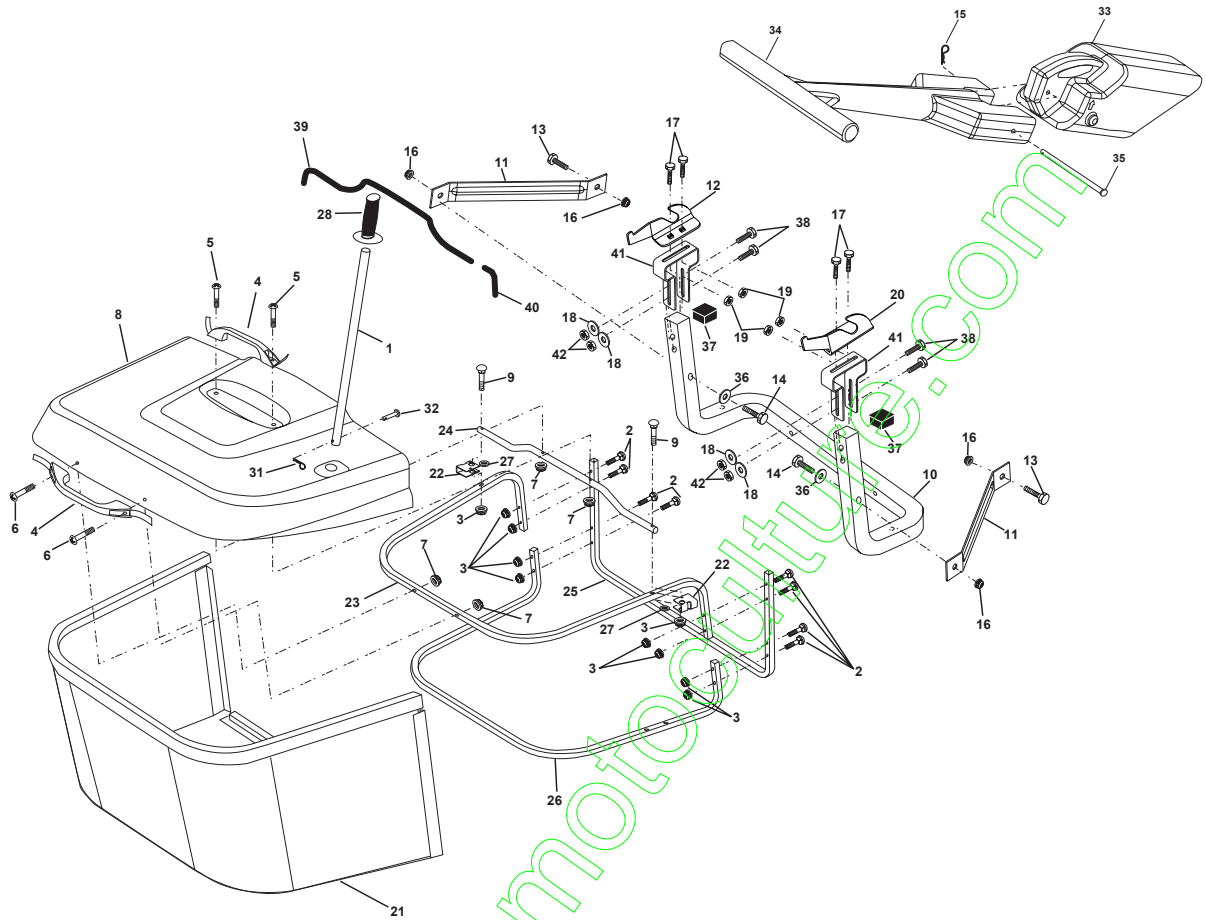

KEY NO.	PART NO.	DESCRIPTION	KEY NO.	PART NO.	DESCRIPTION
1	532170690	Tube Handle Bagger CRD	22	532165781	Bracket Side Bagger CRD
2	872140416	Bolt Carriage 1/4-20 x 2.0 Gr.5	23	532165782	Tube Upper Bagger CRD
3	532123976	Nut Lock 1/4 Lge Flg Gr. 5 Zinc	24	532165783	Tube Pivot Bagger CRD
4	532169916	Handle Bagger w/Lvrs Blk CRD	25	532165784	Tube Front Bagger CRD
5	874981024	Screw Pan Head #10-24 x 1.50 Blk	26	532165785	Tube Lower Bagger CRD
6	874981032	Screw Pan Hd	27	532169692	Bushing Snap Bagger CRD
7	873401000	Nut Wiz Lock Hex Serr/Hd 10-24	28	532170696	Grip Handle Black
8	532167980	Cover Bagger Plastic CRD MS422	31	532124788	Retainer Spring 1" Zinc/Cad
9	872140418	Bolt Carriage 1/4-20 x 2.25d x Gr.5	32	532126875	Rivet Rd Hd Drilled 3/8 Dia
10	532169688	Tube Support Bagger CRD	33	532165571	Plug Mulcher
11	532165719	Bracket Support Upper Bag CRD	34	532165570	Handle Mulcher
12	532169685	Bracket Horiz Adj Bagger Lh	35	532165572	Pin Mulcher
13	872110606	Bolt Rdhd Sht Sqnk 3/8-16 x 3/4	36	819132016	Washer 13/32 x 1-1/4 x 16 Ga.
14	874520640	Bolt Hex 3/8-16 x 2-1/2 Gr.5	37	532175401	Plug Support Bagger CRD
15	532124670	Retainer Spring	38	872010520	Bolt 5/16-18 x 2-1/2
16	873900600	Nut Lock Flg 3/8-16 Unc	39	532169999	Seal 26"
17	872140506	Bolt Rdhd Sht Sqnk 5/16 -18 Unc x 3/4	40	532170000	Seal 27"
18	819111216	Washer 11/32 x 3/4 x 16 Ga.	41	532169683	Bracket Pnt Adj Pvt Bagger CRD
19	873900500	Nut Lock Hex Flange 5/16-18	42	873800500	Nut Crownlock 5/16-18 Blk D
20	532169684	Bracket Horiz Adj Bagger Rh			
21	532165780	Bag Asm CRD			

**NOTE:** All component dimensions given in U.S. inches  
1 inch = 25.4 mm

# TRACTOR- -MODEL NO. CTH150 (HECTH150B), PRODUCT NO. 954 17 00-38 SCHEMATIC

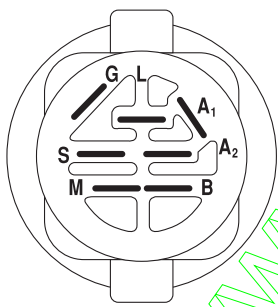
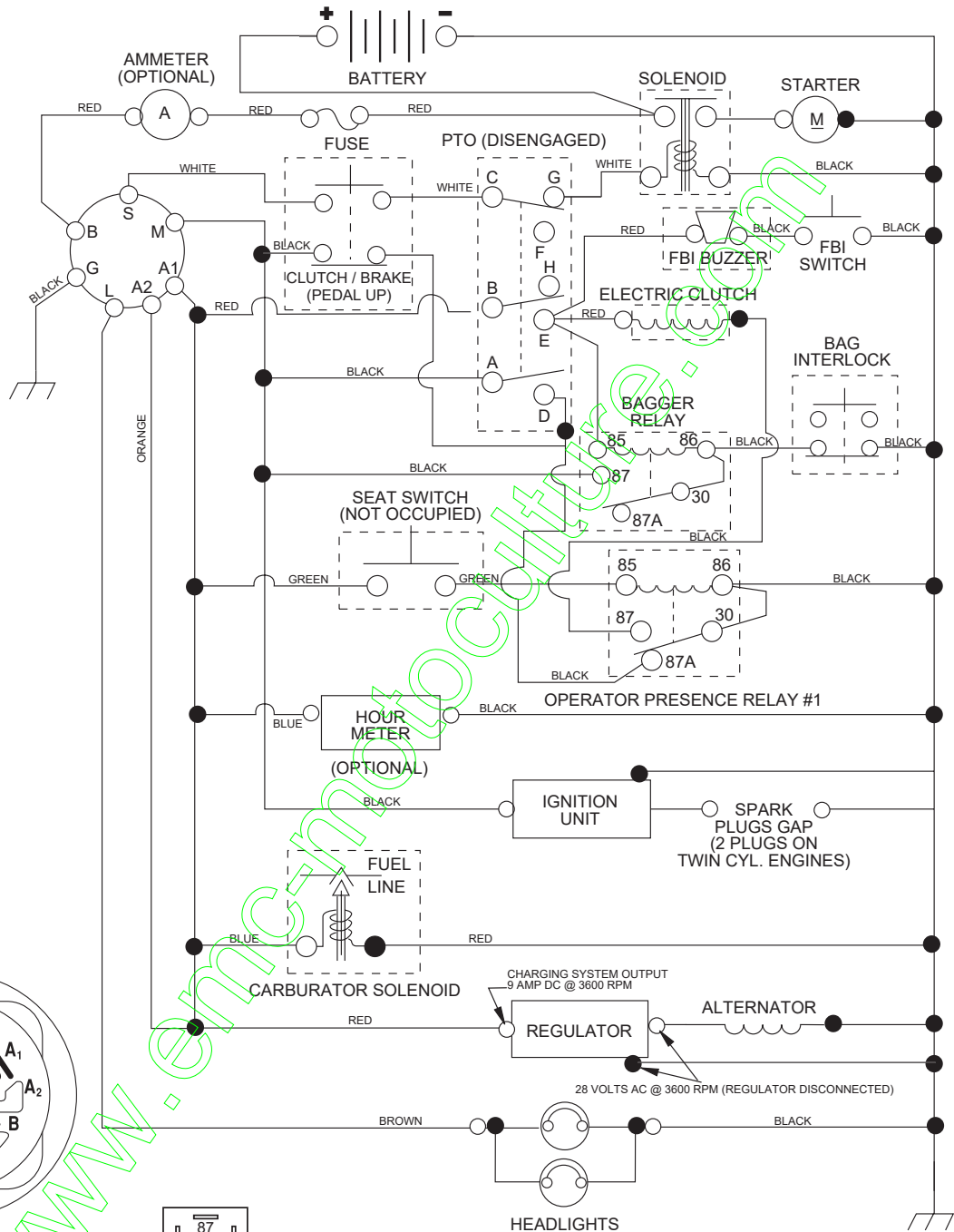

## IGNITION SWITCH

POSITION	CIRCUIT	"MAKE"
OFF	M+G+A1	NONE
RUN/LIGHT	B+A1	A2+L
RUN	B+A1	NONE
START	B + S + A1	NONE

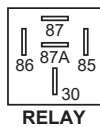

## RELAY

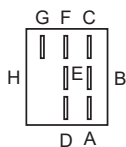

## PTO SWITCH

POSITION	CIRCUIT
OFF	C + G, B + H
ON	C + F, B + E, A + D

NON-REMOVABLE CONNECTIONS

REMOVABLE CONNECTIONS

**WIRING INSULATED CLIPS**  
NOTE: IF WIRING INSULATED CLIPS WERE REMOVED FOR SERVICING OF UNIT, THEY SHOULD BE REPLACED TO PROPERLY SECURE YOUR WIRING.