

# CTH155

**Spare parts**  
**Ersatzteile**  
**Pièces détachées**  
**Reserve onderdelen**  
**Repuestos**  
**Reservdelar**

[www.emc-motoculture.com](http://www.emc-motoculture.com)

# REPAIR PARTS

TRACTOR- -MODEL NO. CTH155 (HECTH155A), PRODUCT NO. 954 17 00-51  
ELECTRICAL

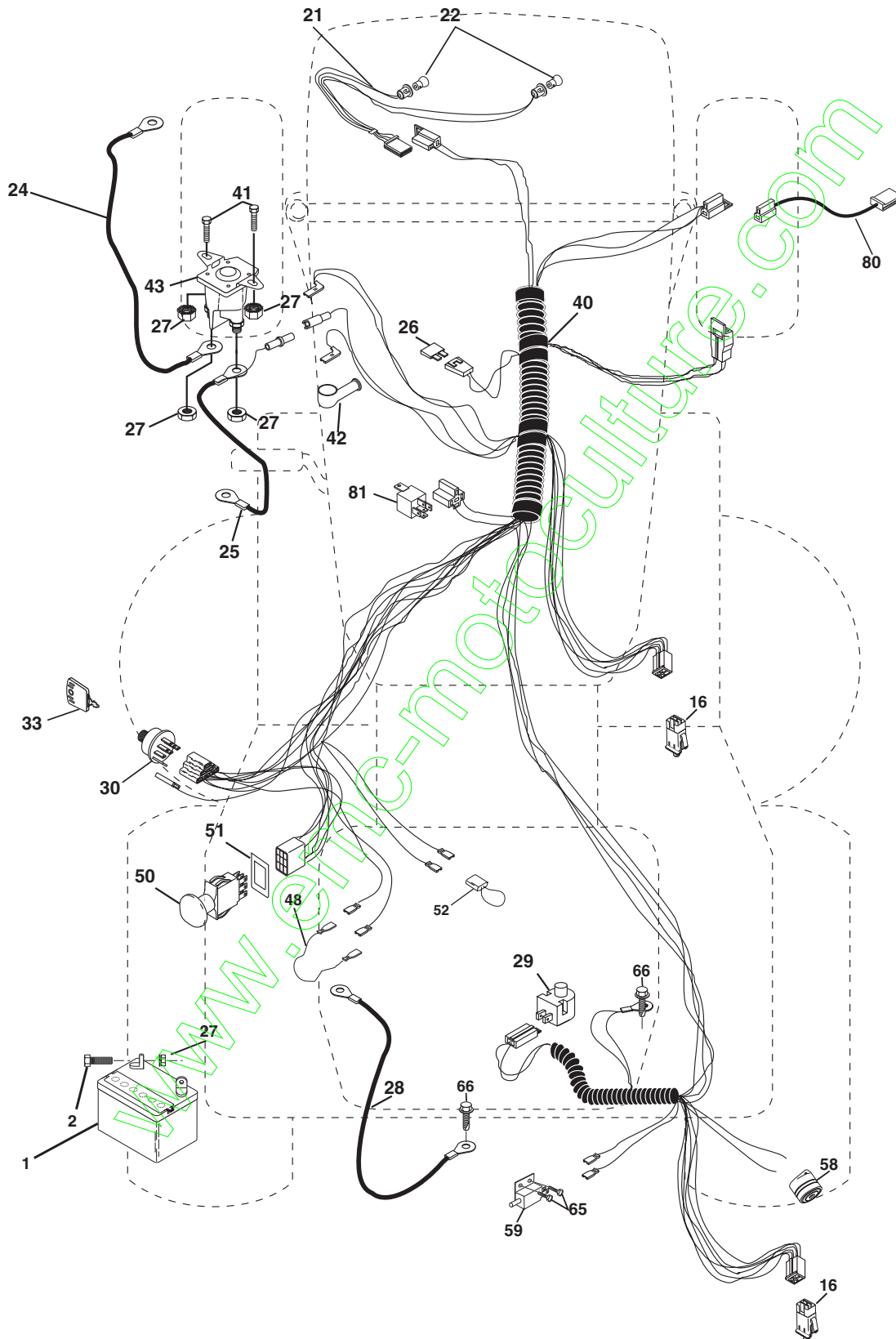

# REPAIR PARTS

TRACTOR- -MODEL NO. CTH155 (HECTH155A), PRODUCT NO. 954 17 00-51  
ELECTRICAL

KEY NO.	PART NO.	DESCRIPTION
1	532 16 34-65	Battery
2	874 76 04-12	Bolt Hex Hd 1/4-20 Unc X 3/4
16	532 17 61-38	Switch Interlock
21	532 16 61-81	Harness Asm Light W/4152J
22	532 00 41-52	Bulb Light #1156
24	532 12 47-80	Cable Starter 6Ga 11" Red
25	532 16 59-87	Cable Battery Crd 56" Red
26	532 17 51-58	Fuse
27	873 51 04-00	Nut Keps Hex 1/4-20 Unc
28	532 12 77-25	Cable Ground 6Ga 18" Black
29	532 16 07-84	Switch Plunger Normal Op Olive
30	532 17 55-66	Switch Ignition
33	532 14 04-01	Key Ign
40	532 17 97-27	Harness Ign
41	871 11 04-08	Bolt Flk Fin Hex 1/4-20 Unc X 1/2
42	532 13 15-63	Cover Terminal Red
43	532 17 88-61	Solenoid
48	532 14 08-44	Adapter Ammeter Rectangular
50	532 17 46-51	Switch PTO
51	532 14 04-05	Ring Retainer PTO
52	532 14 19-40	Protection Wire Loop
58	532 16 94-19	Buzzer Crd
59	532 18 03-79	Switch FBI CRD
66	817 49 06-08	Screw Thdrol 3/8-16 x 1/2 Ty-Tt
80	532 14 66-85	Harness Clutch EVX
81	532 10 97-48	Relay Asm

**NOTE:** All component dimensions given in U.S. inches.  
1 inch = 25.4 mm.

# REPAIR PARTS

TRACTOR- -MODEL NO. CTH155 (HECTH155A), PRODUCT NO. 954 17 00-51  
CHASSIS AND ENCLOSURES

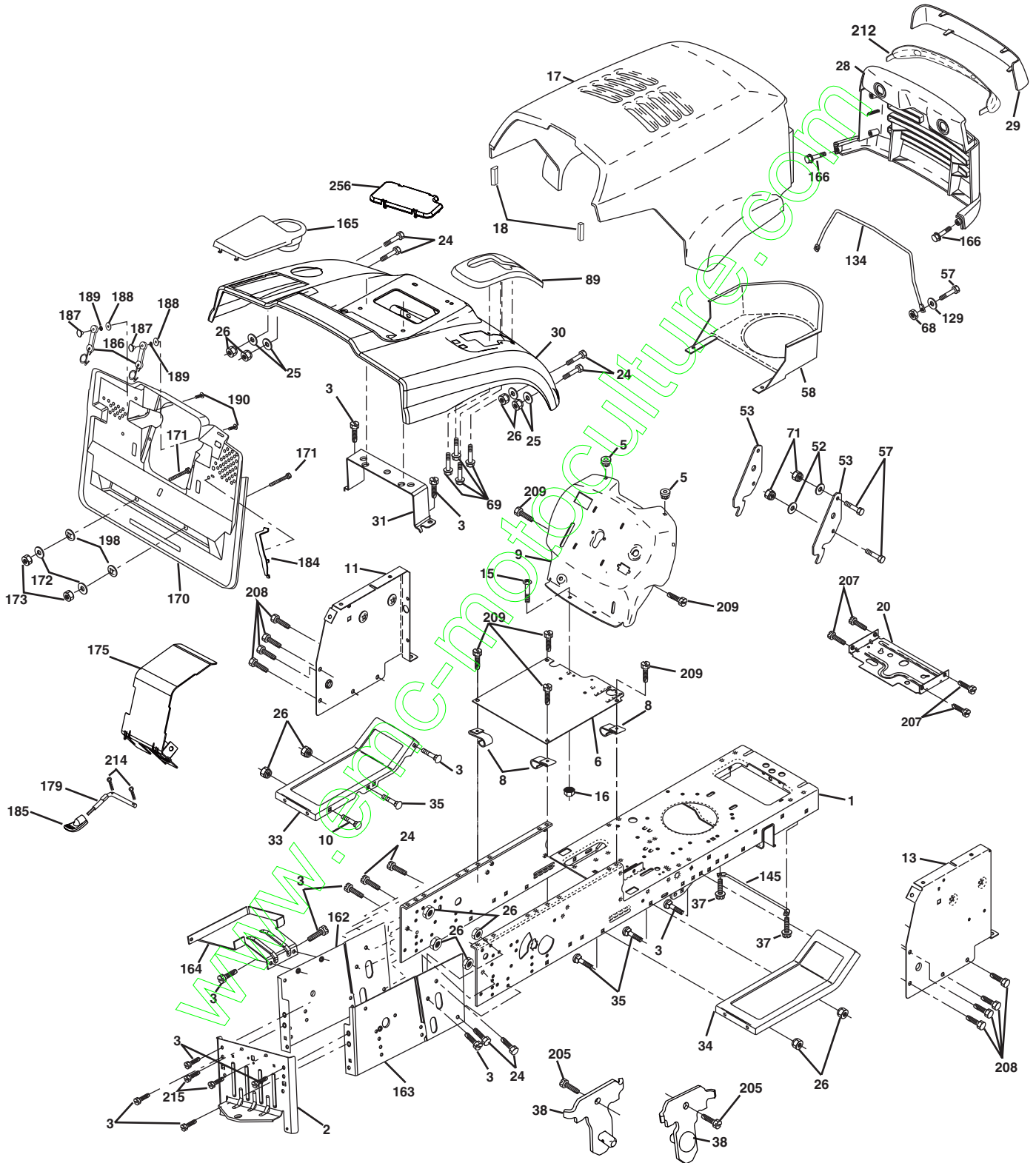

# REPAIR PARTS

## TRACTOR- -MODEL NO. CTH155 (HECTH155A), PRODUCT NO. 954 17 00-51 CHASSIS AND ENCLOSURES

KEY NO.	PART NO.	DESCRIPTION	KEY NO.	PART NO.	DESCRIPTION
1	532 17 46-20	Chassis	89	532 18 10-99	Console
2	532 18 03-84	Drawbar	129	819 09 10-16	Washer 9/32 x 5/8 x 16 Ga.
3	817 06 06-12	Screw 3/8-16 x 3/4	134	532 16 02-19	Rod Support Hood
5	532 15 52-72	Bumper Hood/Dash	145	532 15 65-24	Rod Pivot Chassis/Hood
6	532 15 59-23	Saddle	162	532 18 03-82	Bracket Exten Chassis Lh CRD
8	532 12 64-71	Clip Insulator 13/32 Mtg. Hole	163	532 18 03-83	Bracket Exten Chassis Rh CRD
9	532 17 11-91	Dash	164	532 16 56-05	Support Battery CRD
10	872 14 06-08	Bolt, Carriage 3/8-16 x 3/4	165	532 18 11-00	Cover Battery
11	532 15 59-27	Panel, Dash, L.H.	166	532 16 48-63	Screw HwHd Hi-Lo #13-16 x 3/4
13	532 17 21-08	Panel, Asm. Dash R.H.	170	532 17 88-62	Backplate
15	874 18 05-12	Screw, Machine, Truss Head 5/16-18 UNC x 3/4	171	872 14 06-20	Bolt Rdhd Sqnk 3/8-16 x 2-1/2 Gr. 5
16	873 51 05-00	Nut	172	819 13 20-16	Washer 13/32 x 1-1/4 x 16 Ga.
17	532 16 53-78	Hood	173	873 51 06-00	Nut, Keps Hex 3/8-16 UNC
18	532 12 69-38	Bumper Hood	175	532 18 03-10	Guard Trap
20	532 18 06-79	Plate Mtg Battery/Tank Fuel Fr.	179	532 18 03-76	Rod Pivot FBI CRD
24	874 78 06-16	Bolt	184	532 17 46-62	Bracket Actuator Bagger CRD
25	819 13 13-12	Washer 13/32 x 13/16 x 12 Gauge	185	532 18 11-01	Knob Rod Brake Parking
26	873 80 06-00	Nut	186	532 16 07-93	Latch Asm Mulch/Bagger
28	532 16 53-79	Grille /Lens Asm	187	532 12 50-04	Nut Weld
29	532 16 53-80	Lens, Grille	188	819 06 12-16	Washer #10
30	532 17 96-45	Fender	189	810 07 10-00	Washer Lock #10
31	532 16 51-56	Bracket, Fender Support	190	871 08 10-10	Screw Pan Hd Phillip 10-24 x 5/8
33	532 18 10-57	Footrest, L.H.	198	532 16 89-37	Nut, Push
34	532 18 10-58	Footrest, R.H.	205	817 49 06-08	Screw Thdrol 3/8-16 x 1/2
35	872 11 06-06	Bolt	207	817 67 05-08	Screw Thdrol 5/16-18 x 1/2
37	817 49 05-08	Screw Thdrol 5/16-18 x 1/2 TYT	208	817 67 06-08	Screw Thdrol 3/8-16 x 1/2
38	532 17 57-10	Bracket Asm Pivot Mower Rear	209	817 00 06-12	Screw Hex Wsh Thdrol 3/8-16
52	819 09 14-16	Washer 9/32 x 7/8 x 16 Ga.	212	532 15 61-95	Insert Lens Reflective
53	532 15 00-67	Bracket Pick Off	214	532 12 47-88	Retainer Spring
57	874 78 04-12	Bolt Fin Hex 1/4-20 Unc x .75	215	817 06 05-08	Screw 5/16-18 x 1/2
58	532 15 01-27	Duct Air Engine	256	532 18 08-10	Cover Fender Rack CRD
68	873 51 04-00	Nut Keps Hex 1/4-20 Unc	--	532 00 54-79	Plug, Button
69	532 14 24-32	Screw Hex Wsh			
71	873 68 04-00	Nut Crownlock 1/4-20 Unc			

**NOTE:** All component dimensions given in U.S. inches.  
1 inch = 25.4 mm.

# REPAIR PARTS

TRACTOR- -MODEL NO. CTH155 (HECTH155A), PRODUCT NO. 954 17 00-51  
DRIVE

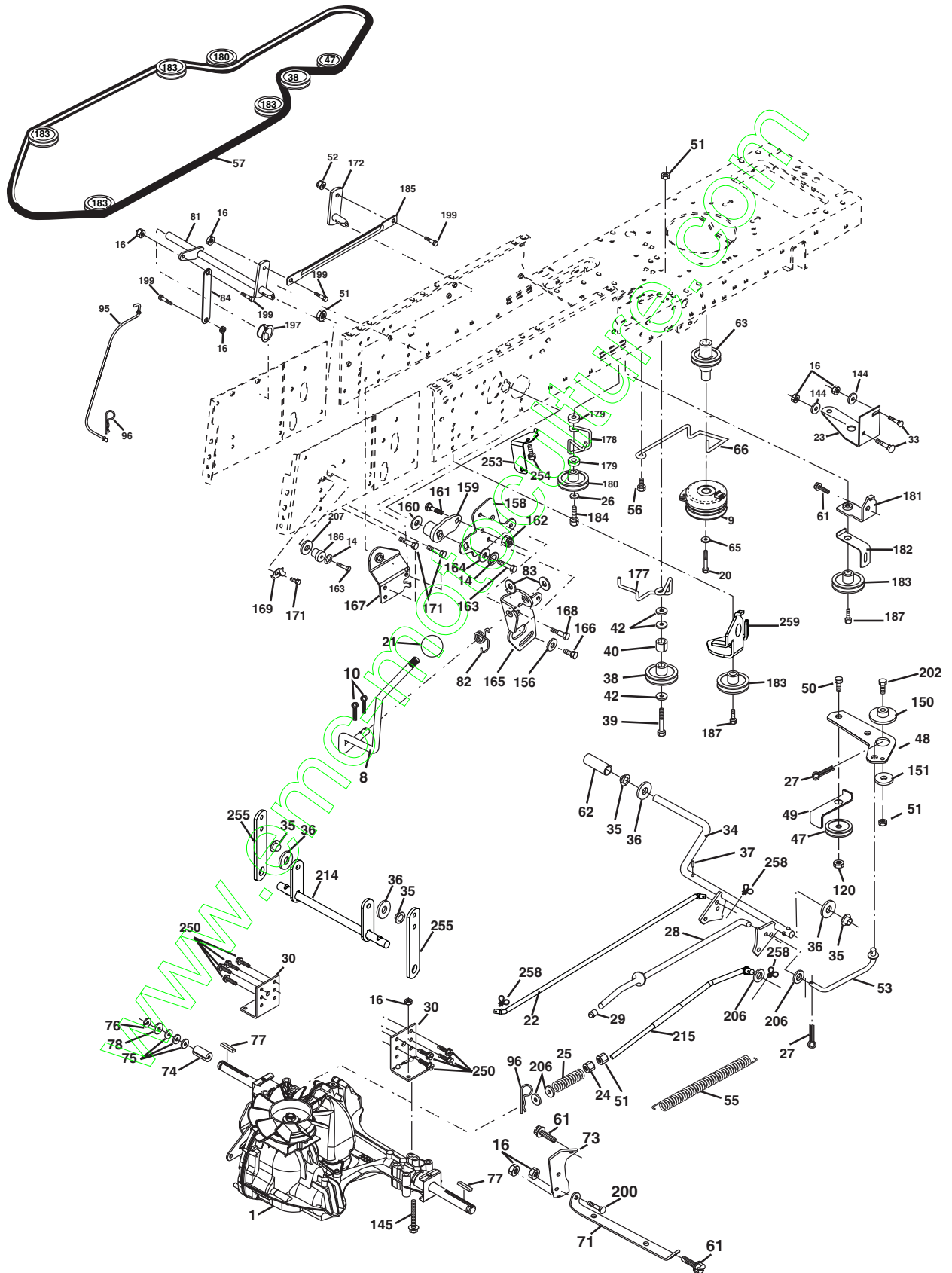

# REPAIR PARTS

TRACTOR- -MODEL NO. CTH155 (HECTH155A), PRODUCT NO. 954 17 00-51  
DRIVE

KEY NO.	PART NO.	DESCRIPTION	KEY NO.	PART NO.	DESCRIPTION
1	-----	Transaxle Hydro Gear 321-0510 (Order parts from transaxle manufacturer)	83	819 17 12-16	Washer 17/32 x 3/4 x 16 Ga.
8	532 16 56-19	Rod, Shift Fender Adjust Lt	84	532 17 00-07	Link, Transaxle
9	532 16 71-62	Clutch Ele EVX	95	532 17 00-15	Control Asm Bypass Hydro
10	876 02 04-16	Pin, Cotter 1/8 x 1	96	532 12 47-88	Spring, Retainer 1"
14	810 04 04-00	Washer, Lock Hvy Helical	120	873 90 06-00	Nut Lock Fig. 3/8-16 Unc
16	873 80 05-00	Nut, Lock Hex w/Ins 5/16-18 UNC	144	819 11 10-16	Washer 11/32 x 5/8 x 16 Ga.
20	532 15 02-80	Bolt, Hex 7/16-20 x 4-1/4 5 Ga 1.38	145	874 49 05-44	Bolt Hex FGHD 5/16-18 x Gr 5
21	532 12 12-74	Knob Duckhead 1/4-13 Unc Blk	150	532 16 58-50	Bushing, Bellcrank Grnd Dr
22	532 17 56-07	Rod, Brake	151	819 13 32-10	Washer 13/32 x 2 x 10 Ga.
23	532 17 12-58	Bracket asm Anti-Rot	156	532 16 60-02	Washer Srrted 5/16ID x 1.125
24	873 35 06-00	Nut	158	532 16 55-89	Bracket Shift Mount
25	532 10 68-88	Spring, Rod, Brake	159	532 16 54-94	Hub Tapered Flange Shift Lt
26	819 13 13-16	Washer 13/32 x 13/16 x 16 Ga.	160	819 29 20-16	Washer 29/32 x 1-1/4 x 16 Ga.
27	876 02 04-12	Pin, Cotter 1/8 x 3/4	161	872 14 04-06	Bolt Rdhd Sqnk 1/4-20 x 3/4 Gr 5
28	532 17 57-65	Rod, Parking Brake	162	873 68 04-00	Nut Crownlock 1/4-20 Unc
29	532 07 16-73	Cap, Parking Brake	163	874 78 04-16	Bolt Hex Fin 1/4-20 Unc x 1 Gr 5
30	532 16 95-92	Bracket, Mfg. Transaxle	164	819 09 10-10	Washer 5/8 x .281 x 10 Ga.
33	872 14 05-06	Bolt Rdhd Sqnk 5/16-18 Unc x 3/4	165	532 16 56-23	Bracket Pivot Lever
34	532 17 55-78	Shaft, Asm Pedal Foot CRD	166	532 16 68-80	Screw 5/16-18 x 5/8
35	532 12 01-83	Bearing, Nylon	167	532 16 55-88	Bracket Support Shift CRD
36	819 21 16-16	Washer 21/32 x 1 x 16 Ga.	168	532 16 54-92	Bolt Shoulder 5/16-18 x .561
37	532 12 49-63	Pin, Roll 3/16 x 1"	169	532 16 55-80	Plate Fastening Lt
38	532 16 59-36	Pulley Flat Composite 3.06"	171	817 49 06-08	Screw Thdrol 3/8-16 x 1/2 Ty-Tt
39	874 76 06-44	Bolt Fin Hex 3/8-16 Unc x 2-3/4	172	532 17 02-71	Shaft Asm Shifter Frt CRD
40	532 12 49-65	Spacer, Split 395 x 59 Bzp	174	810 09 04-00	Washer Lock 1/4
42	819 13 13-12	Washer 13/32 x 13/16 x 12 Ga.	177	532 16 59-32	Keeper Flat Idler 3.06" CRD
47	532 12 77-83	Pulley, Idler, V Groove Plasic	178	532 16 59-33	Keeper Belt Idler 1.88" CRD
48	532 15 44-07	Bellcrank Clutch Grnd Drv	179	532 12 09-58	Washer Sintered
49	532 12 32-05	Retainer, Belt Style Spring	180	532 16 56-30	Pulley, Idler, Flat 1.88" CRD
50	874 76 06-24	Bolt Hex Hd 3/8-16 UNC x 1-1/2	181	532 18 02-11	Bracket Idler Ground Drive CRD
51	873 68 06-00	Nut, Crownlock 3/8-16 UNC	182	532 16 56-34	Keeper Belt 2.5" Od V-Idler CRD
52	873 68 05-00	Nut Crownlock 5/16-18	183	532 17 90-50	Pulley V-Idler 2.50" Od CRD
53	532 10 57-10	Link, Clutch 7.66	184	817 49 06-44	Screw Hexwsh Thdrol 3/8-16 x 2-3/4
55	532 10 57-09	Spring, Return, Clutch	185	532 17 00-08	Link Shift
56	817 06 06-20	Screw 3/8-16 x 1-1/4	186	532 16 56-14	Hub Tapered Round CRD
57	532 17 01-40	V-Belt Kev 112" 0650 CRD	187	817 58 05-20	Screw Thdrol 5/16-18 x 1.25
61	817 06 06-12	Screw 3/8-16 x 3/4	197	532 16 96-13	Nyliner Snap-In 5/8
62	532 12 35-33	Cover, Pedal	199	532 16 96-12	Bolt Shoulder 5/16-18 Unc
63	532 14 58-68	Pulley, Clutch elect EVX 1"	200	872 14 05-08	Bolt RDHD SQNK 5/16-18 x 1
65	810 04 07-00	Washer	202	872 11 06-12	Bolt Carr. Sh. 3/8-16 x 1-1/2 Gr. 5
66	532 15 47-78	Keeper, Belt Engine F-Proof	206	819 13 14-16	Washer 13/32 x 7/8 x 16 Ga.
71	532 16 91-83	Strap, Torque, Lh	207	532 16 98-45	Washer Nylon Rear
73	532 16 91-82	Strap, Torque, Rh	214	532 17 56-09	Shaft Asm. Brake
74	532 13 70-57	Spacer, Split	215	532 17 56-52	Rod Brake Hydro
75	532 12 17-49	Washer 25/32 x 1-1/4 x 16 Ga.	250	817 07 06-12	Screw 3/8-16 x .75
76	812 00 00-01	Ring, E	253	532 17 50-28	Bracket Cable Chassis
77	532 12 35-83	Key, Square	254	817 06 06-16	Screw 3/8-16 x 1
78	532 12 17-48	Washer 25/32 x 1-5/8 x 16 Ga.	255	532 17 56-08	Brace Shaft Brake Mtg.
81	532 17 00-06	Asm, Shaft	258	532 17 80-62	Clip Retainer
82	532 12 37-82	Spring, Torsion			

**NOTE:** All component dimensions given in U.S. inches  
1 inch = 25.4 mm

# REPAIR PARTS

TRACTOR- -MODEL NO. CTH155 (HECTH155A), PRODUCT NO. 954 17 00-51  
STEERING ASSEMBLY

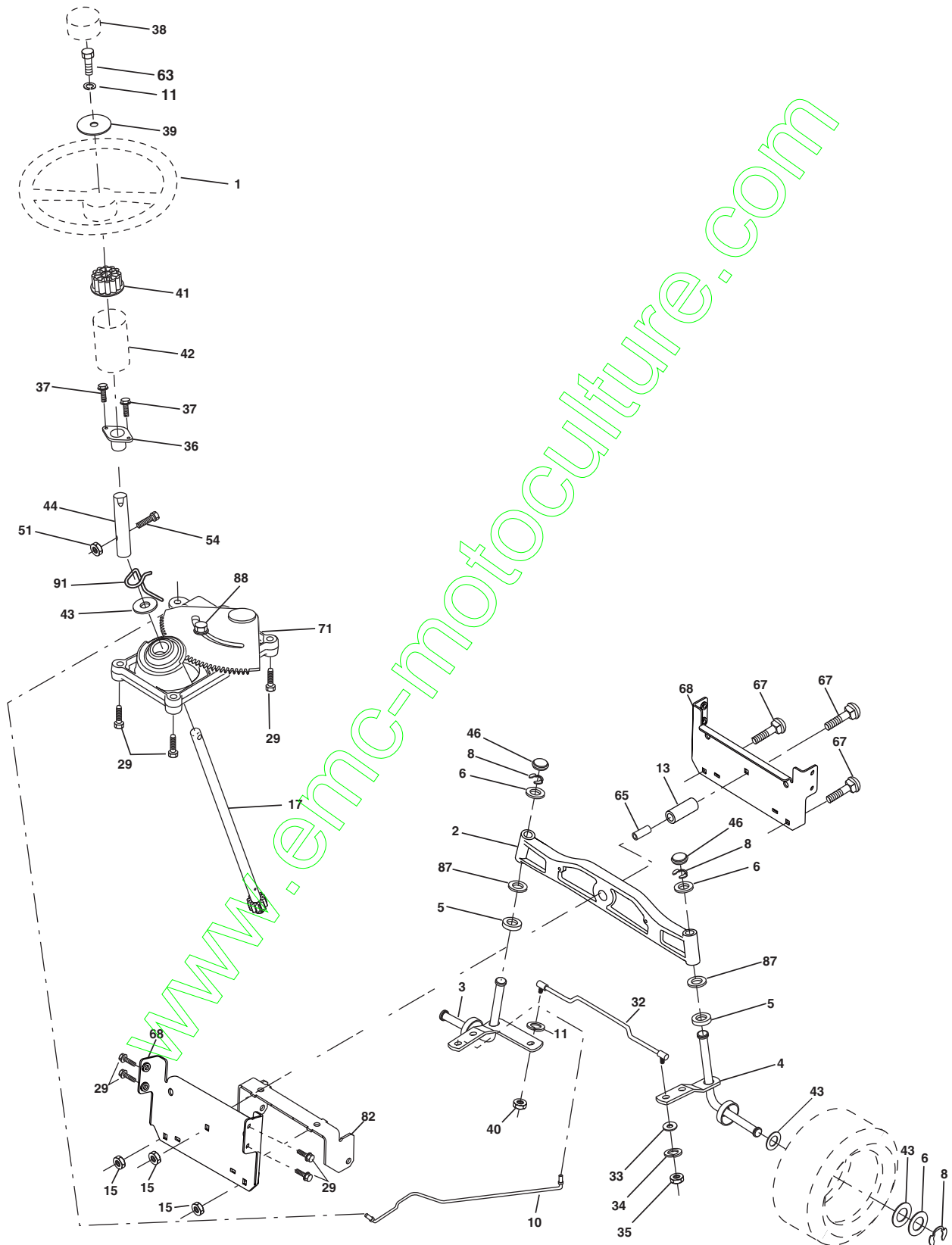



# REPAIR PARTS

TRACTOR- -MODEL NO. CTH155 (HECTH155A), PRODUCT NO. 954 17 00-51  
STEERING ASSEMBLY

KEY NO.	PART NO.	DESCRIPTION
1	532 16 66-27	Steering Wheel
2	532 17 23-93	Front Axle Assembly
3	532 16 98-40	Spindle Assembly, L.H.
4	532 16 98-39	Spindle Assembly, R.H.
5	532 12 49-31	Bearing, Race, Thrust, Hardened
6	532 12 17-48	Washer 25/32 x 1-5/8 x 16 Gauge
8	812 00 00-29	Ring, Klip
10	532 17 51-21	Link, Drag
11	810 04 06-00	Washer, Lock
13	532 13 65-18	Spacer Axle
15	532 14 52-12	Nut Hex Flange Lock
17	532 17 78-76	Shaft Assembly, Steering
29	817 06 06-12	Screw 3/8-16 x 3/4
32	532 17 18-88	Rod, Tie
33	819 11 12-16	Washer 11/32 x 3/4 x 16 Ga.
34	810 04 05-00	Washer Lock Hvy Hlcl Spr 5/16
35	873 54 05-00	Crownlock Nut 5/16-24 Unf
36	532 15 50-99	Bushing, Steering
37	532 15 29-27	Screw TT #10-32 x 5 x 3/8 Flange
38	532 16 66-26	Cap Wheel Steer
39	819 13 24-11	Washer 13/32 x 1-1/20 x 11 Gauge
40	532 12 47-01	Nut Lock Center 3/8-24 Unf
41	532 15 99-45	Adaptor, Steering Wheel
42	532 16 96-34	Boot, Steering Dash P/L Mtl
43	532 12 17-49	Washer 25/32 x 1-1/4 x 16 Gauge
44	532 15 37-20	Extension Steering
46	532 12 12-32	Cap, Spindle
51	873 80 05-00	Nut Lock Hx W/Ins 5/16-18 UNC
54	874 78 05-20	Bolt Fin Hex 5/16-18 UNC x 1-1/4
63	874 78 06-16	Bolt Fin Hex 3/8-16 unc. x 1 Gr. 5
65	532 16 03-67	Spacer Axle
67	872 14 06-18	Bolt Rdhd Sq 3/8-16 x 2-1/4
68	532 16 98-27	Brace Axle
71	532 17 51-46	Steering Asm.
82	532 16 98-35	Bracket Susp. Chassis Front
87	532 17 39-66	Washer Flat .781 x 1-1/2 x .14
88	532 17 51-18	Bolt Shoulder 7/16-20 Unc
91	532 17 55-53	Clip Steering

**NOTE:** All component dimensions given in U.S. inches.  
1 inch = 25.4 mm.

# REPAIR PARTS

TRACTOR- -MODEL NO. CTH155 (HECTH155A), PRODUCT NO. 954 17 00-51  
SEAT ASSEMBLY

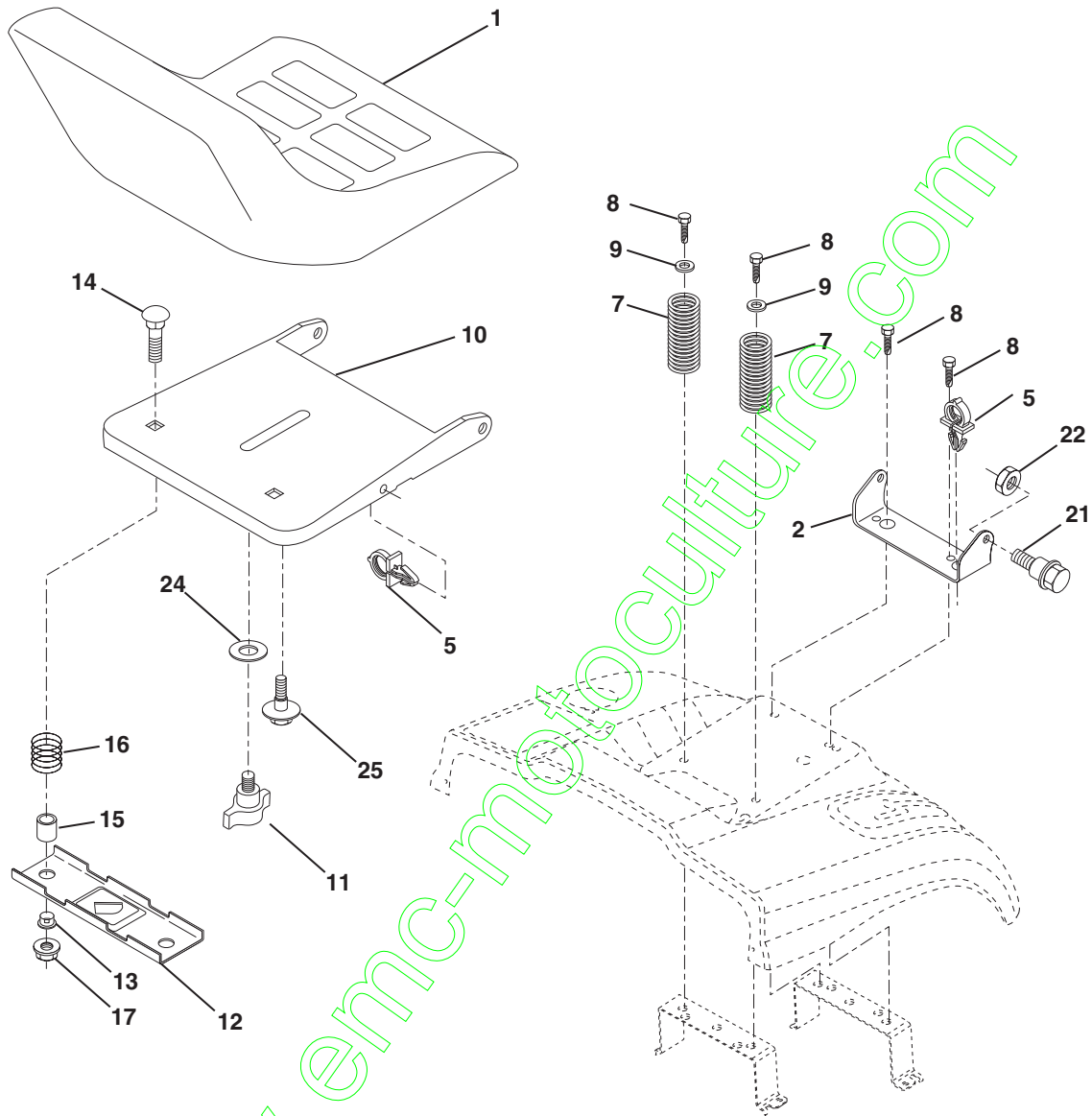

KEY NO.	PART NO.	DESCRIPTION
1	532 14 08-40	Seat
2	532 14 05-51	Bracket Pnt Pivot Seat (blk )
5	532 14 50-06	Clip Push In Hinged
7	532 12 41-81	Spring Seat Cprsn 2 250 Blk Zi
8	817 00 06-16	Screw 3/8-16 X 1.5
9	819 13 16-14	Washer 13/32 X 1 X 14 Ga
10	532 17 48-94	Pan Pnt Seat (blk )
11	532 16 63-69	Knob Seat Adj. Wingnut
12	532 12 12-46	Bracket Pnt Mounting Switch
13	532 12 12-48	Bushing Snap Blk Nyl 50 Id

KEY NO.	PART NO.	DESCRIPTION
14	872 05 04-12	Bolt Rdhd Sht Nk 1/4-20x1-1/2
15	532 12 12-49	Spacer Split
16	532 12 37-40	Spring Cprsn
17	532 12 39-76	Nut Lock 1/4 Lge Flg Gr 5 Zinc
21	532 17 18-52	Bolt Shoulder 5/16-18 Unc-2A
22	873 80 05-00	Nut Hex Lock w/Ins 5/16-18
24	819 17 19-12	Washer 17/32 X 1-3/16 X 12 Ga.
25	532 12 70-18	Bolt Shoulder 5/16-18 X 62

**NOTE:** All component dimensions given in U.S. inches.  
1 inch = 25.4 mm

# REPAIR PARTS

TRACTOR- -MODEL NO. CTH155 (HECTH155A), PRODUCT NO. 954 17 00-51  
DECALS

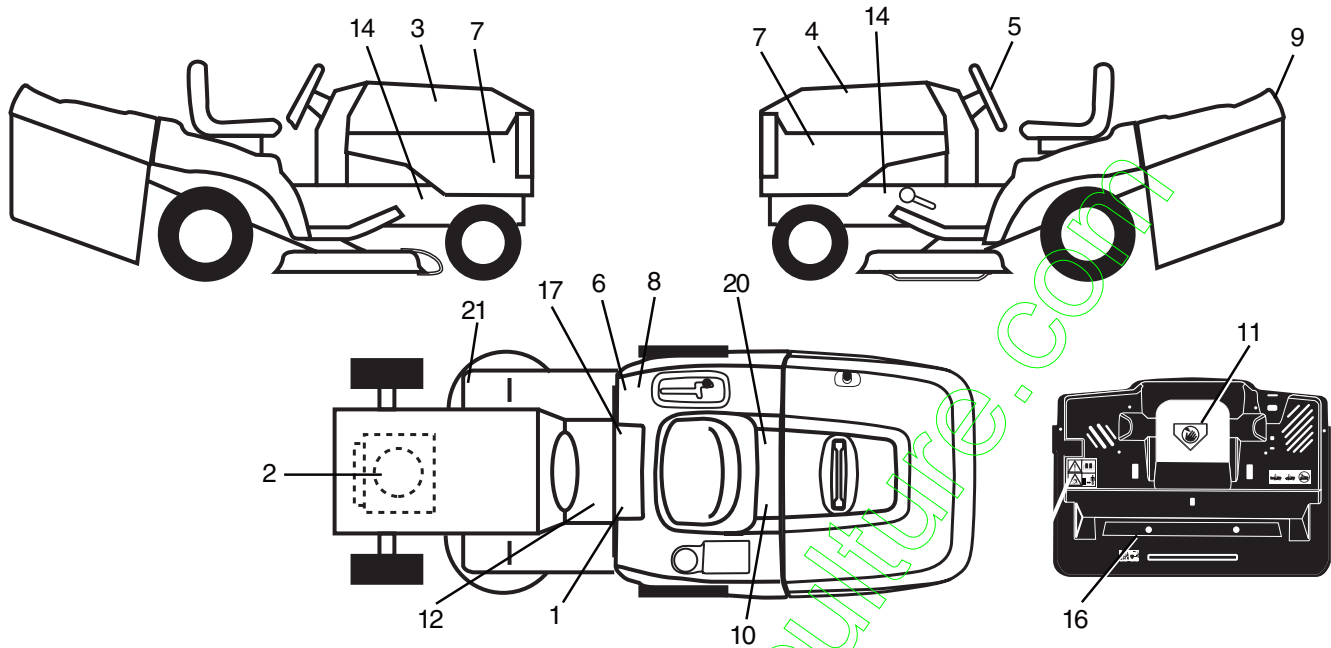

KEY NO.	PART NO.	DESCRIPTION	KEY NO.	PART NO.	DESCRIPTION
1	532 1454-98	Decal Read Owner's Manual Sym	12	532 1597-37	Decal Brake/Clutch Symbol Lt
2	532 1804-34	Decal Hp Engine	14	532 1597-36	Decal Chassis Hot Muffler
3	532 1796-75	Decal Hood Rh	16	532 1804-35	Decal Backplate
4	532 1796-76	Decal Hood Lh	17	532 1408-37	Decal Saddle Brake Parking
5	532 1705-64	Decal Wheel Steering	20	532 1669-60	Decal Bypass Fender CRD
6	532 1261-87	Decal 100 DBA	21	532 1662-86	Decal Hex Belt Sch 92 CRD
7	532 1597-13	Decal Panel Side B&S Logo	—	532 1383-11	Decal Lift Handle
8	532 1454-37	Decal Europe Stand Ce	—	532 1810-90	Pad Footrest RH
9	532 1506-17	Decal Fender Logo	—	532 1810-91	Pad Footrest LH
10	532 1450-05	Decal Bat Dan/Poi P/L Sym Wpn	—	532 1799-79	Manual Operator's (Euro)
11	532 1454-94	Decal Mower Cut Finger Symbol	—	532 1799-80	Manual Operator's (Scan)

## WHEELS & TIRES

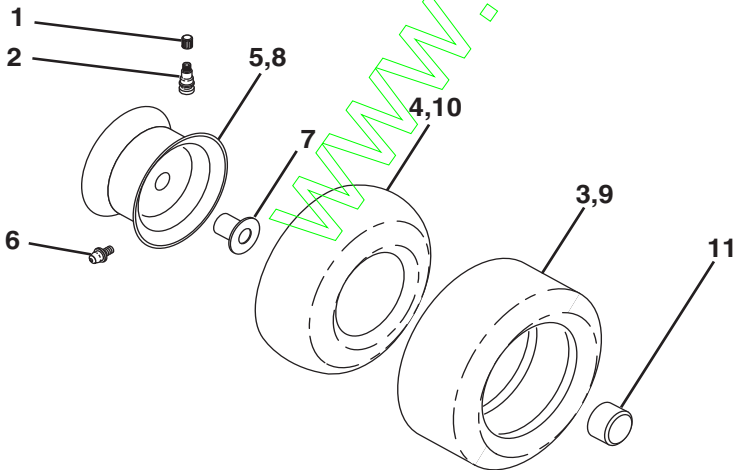

KEY NO.	PART NO.	DESCRIPTION
1	532 0591-92	Cap Value Tire
2	532 0651-39	Stem Value
3	532 1062-22	Tire F Ts 15 X 6 0 - 6 Service
4	532 0599-04	Tube Inner Front #35060
5	532 1383-36	Rim Asm 6" front Silver Service
6	532 1249-57	Fitting Grease
7	532 1249-59	Bearing Flange
8	532 1383-37	Rim Asm 8" rear Silver Service
9	532 1384-68	Tire R Ts 20 x 8-8 Service
10	532 1249-26	Tube Rear 9 5 X 8 Service
11	532 1750-39	Cap Axle Blk 1 50 X 1 00
--	532 1443-34	Sealant, Tire (10 oz. tube)

**NOTE:** All component dimensions given in U.S. inches  
1 inch = 25.4 mm

# REPAIR PARTS

TRACTOR- -MODEL NO. CTH155 (HECTH155A), PRODUCT NO. 954 17 00-51  
ENGINE

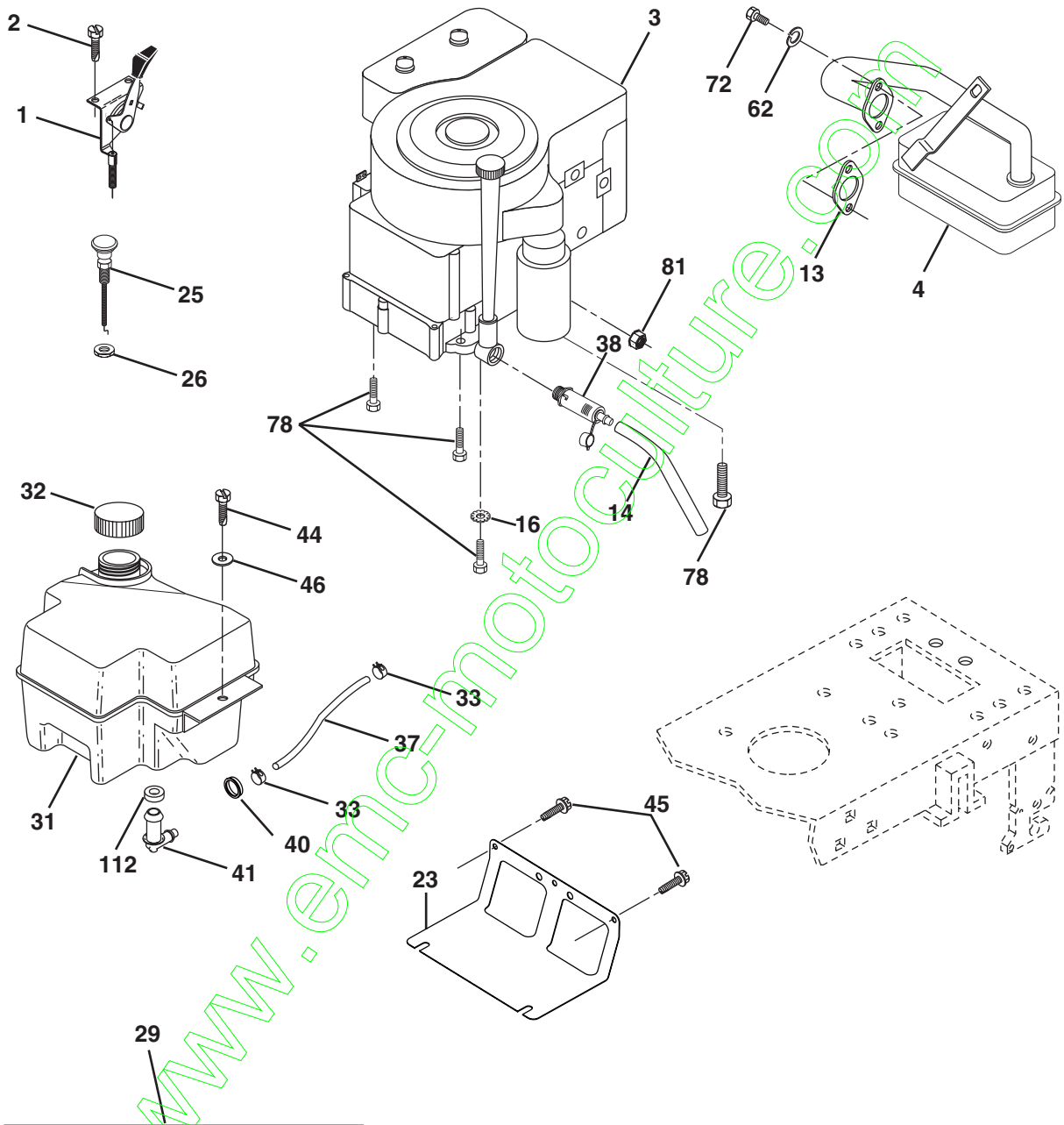

**OPTIONAL EQUIPMENT**  
**Spark Arrester**

# REPAIR PARTS

TRACTOR- -MODEL NO. CTH155 (HECTH155A), PRODUCT NO. 954 17 00-51  
ENGINE

KEY NO.	PART NO.	DESCRIPTION
1	532 17 05-51	Control Throt/Ck
2	817 72 04-08	Screw Hex Thd Cut 1/4-20 x 1/2
3	-----	Engine B&S Model 31G777 (Order parts from engine manufacturer)
4	532 13 73-52	Muffler
13	532 16 52-91	Gasket Muffler
14	532 14 84-56	Tube Drain Oil Easy
16	811 05 06-00	Washer Lock Ext Tooth 3/8
23	532 16 98-37	Shield Brn/Dbr Guard
25	532 18 09-45	Control Choke
26	873 92 06-00	Nut Keps 3/8-24 Unf
29	532 13 71-80	Kit Spark Arrestor (Flat Scrn)
31	532 18 06-45	Tank Fuel 2.00
32	532 14 05-27	Cap Asm Fuel W/sym Vented
33	532 12 34-87	Clamp Hose Blk
37	532 13 70-40	Line Fuel
38	532 14 83-15	Plug Drain Oil Easy
40	532 12 40-28	Bushing Snap
41	532 13 92-77	Stem Fuel Line
44	817 67 04-12	Screw Hexwsh thdrol 1/4-20 x 3/4
45	817 00 06-12	Screw Hexwsh Thdr 3/8-16 x 3/4
46	819 09 14-16	Washer 9/32 x 7/8 x 16 Ga.
62	810 04 05-00	Washer, Lock Hvy. Hlcl Spr 5/16
72	871 07 05-12	Screw Hex Hd Cap 5/16-18 x 3/4
78	817 06 06-20	Screw 3/8-16 x 1/4
81	873 51 04-00	Nut Keps Hex 1/4-20 Unc
112	532 12 49-52	Bushing

**NOTE:** All component dimensions given in U.S. inches  
1 inch = 25.4 mm

# REPAIR PARTS

TRACTOR- -MODEL NO. CTH155 (HECTH155A), PRODUCT NO. 954 17 00-51  
MOWER LIFT

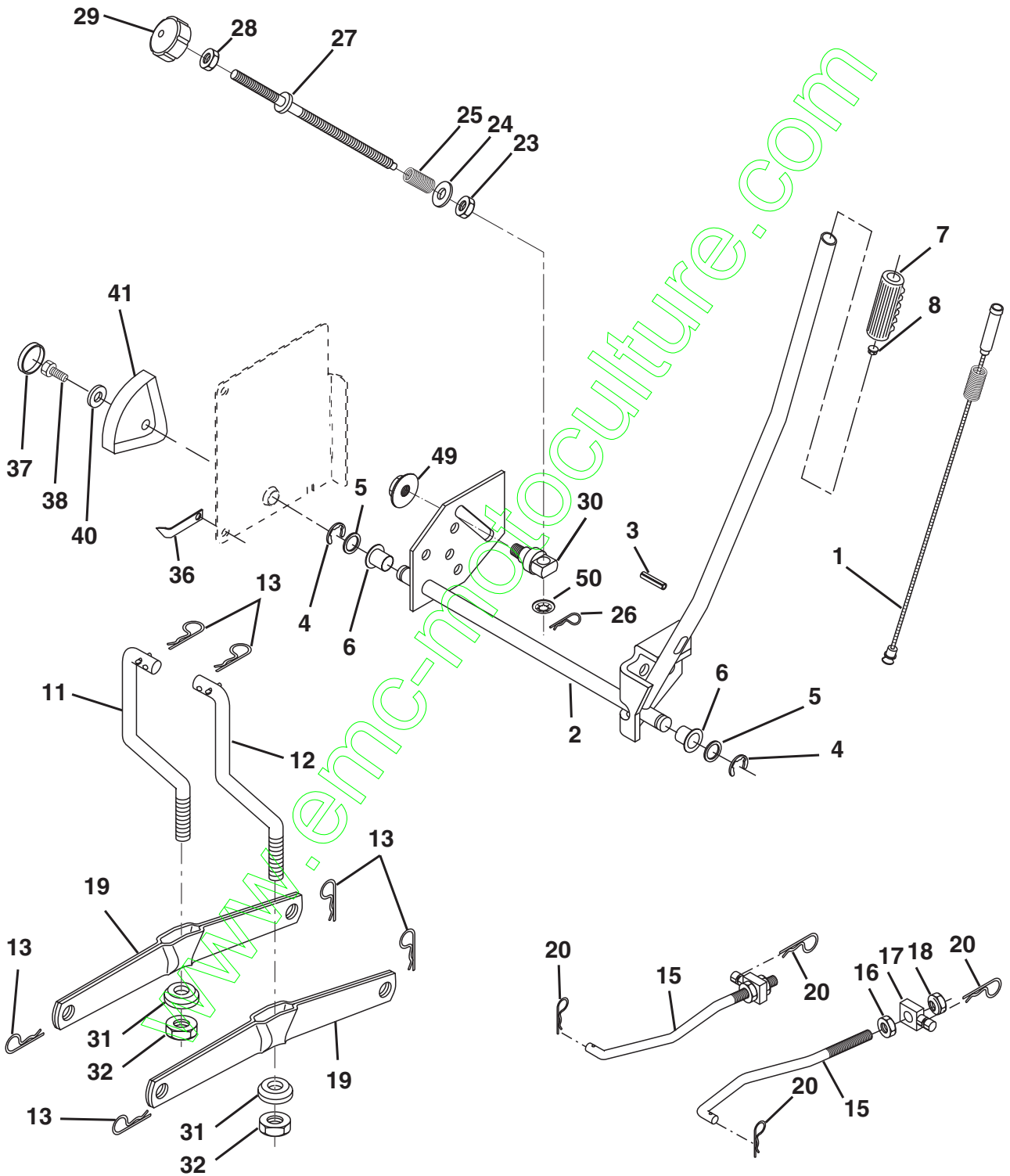

# REPAIR PARTS

TRACTOR- -MODEL NO. CTH155 (HECTH155A), PRODUCT NO. 954 17 00-51  
MOWER LIFT

KEY NO.	PART NO.	DESCRIPTION
1	532 1594-60	Washer Asm Inner Spring W/Plunger
2	532 1594-71	Shaft Asm. Lift
3	532 1057-67	Pin Groove
4	8120000-02	E Ring #5133-62
5	81921 16-21	Washer 21/32 x 1 x 21 Ga.
6	532 1201-83	Bearing Nylon
7	532 1256-31	Grip Handle Fluted
8	532 1245-26	Button Plunger Black
11	532 1658-29	Link Asm Lift L.H.
12	532 1658-31	Link Asm Lift R.H.
13	532 1246-70	Retainer Spring
15	532 1732-88	Link Front
16	8733508-00	Nut Jam Hex 1/2-13 Unc
17	532 1756-89	Trunnion Blk Zinc
18	8738008-00	Nut Lock w/wsh 1/2-13 Unc
19	532 1398-68	Arm Suspension Mower
20	532 1635-52	Retainer Spring
23	532 1108-07	Nut Special
24	819 1310-16	Washer 13/32 x 5/8 x 16 Ga.
25	532 1248-74	Spring 2-1/8"
26	532 1694-84	Retainer Clip
27	532 1269-71	Rod Adj Lift Zinc 7.49 Wrk Lg
28	8733506-00	Nut Hex Jam 3/8-16 Unc
29	532 1380-57	Knob Inf 3/8-16 Unc Blk w/sym
30	532 1502-33	Trunnion Infin Height
31	532 1698-65	Bearing, Pvt. Lift.
32	8735406-00	Nut Crownlock 3/8-24
36	532 1550-97	Pointer Height Indicator
37	532 1239-35	Plug Hole Blk 1.485/1.515 Dia
38	8170605-16	Screw 5/16-18 x 1
40	819 1124-10	Washer 11/32 x 1-1/2 x 10 Ga.
41	532 1239-34	Scale Ind Height Blk
49	532 1452-12	Nut hex Flange Lock
50	532 1104-52	Nut Push Phos & Oil

**NOTE:** All component dimensions given in U.S. inches  
1 inch = 25.4 mm

# REPAIR PARTS

TRACTOR- -MODEL NO. CTH155 (HECTH155A), PRODUCT NO. 954 17 00-51  
MOWER

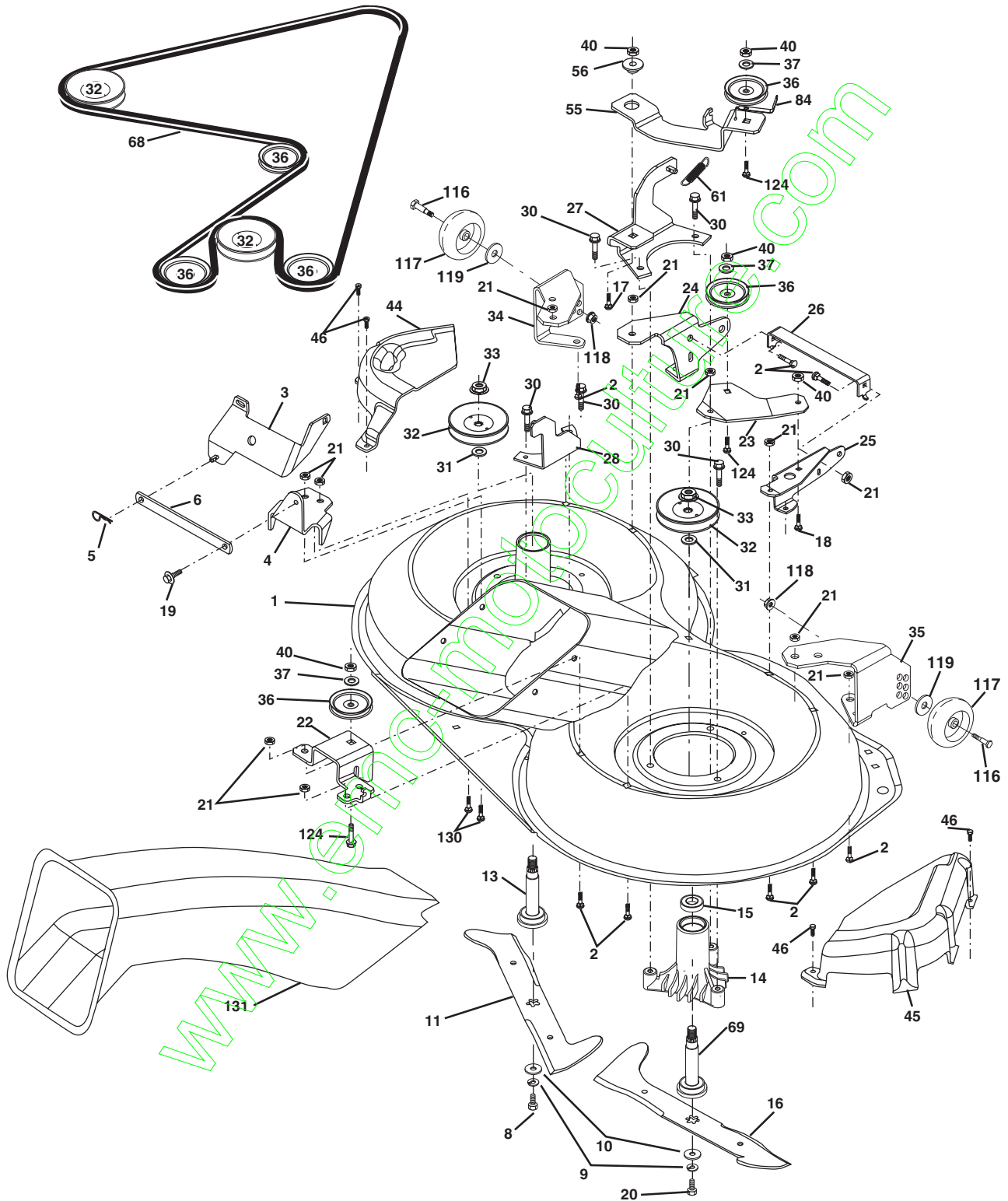



# REPAIR PARTS

TRACTOR- -MODEL NO. CTH155 (HECTH155A), PRODUCT NO. 954 17 00-51  
MOWER

KEY NO.	PART NO.	DESCRIPTION	KEY NO.	PART NO.	DESCRIPTION
1	532 1655-52	Housing Asm. Mower	33	532 1783-42	Nut Flg Top Lock
2	872 1405-06	Bolt Rdhd Sqnk 5/16-18 Unc x 3/4	34	532 1652-39	Bracket Gauge Wheel Lf
3	532 1655-69	Bracket Asm. S-Bar Chass	35	532 1652-38	Bracket Gauge Wheel Rf
4	532 1655-58	Bracket Bar Sway Deck	36	532 1467-63	Pulley Idler V-Groove Dim 4.25
5	532 1246-70	Retainer Spring	37	819 1313-16	Washer 11/32 x 13/16 x 16 Ga
6	532 1655-69	Bracket Asm. S-Bar	40	873 6806-00	Nut Crownlock 3/8-16 Unc
8	532 8508-57	Bolt 3/8-24 x 1.25 Gr8 Patched	44	532 1755-38	Cover Mandrel Lh
9	810 0306-00	Washer Lock Hvy 3/8 Unplated	45	532 1755-39	Cover Mandrel Rh
10	532 1402-96	Washer Hard Blade Mower vented	46	532 1377-29	Screw Thd Roll 1/4-20 x 5/8
11	532 1700-37	Blade 3-1 Lh	55	532 1654-45	Arm Idler
13	532 1376-45	Shaft Asm. W/Lower Bearing	56	532 1657-23	Spacer Retainer Mower
14	532 1287-74	Housing Mandrel Vented (Machd)	61	532 1659-45	Spring Tension Belt
15	532 1104-85	Bearing Ball Mandrel	68	532 1655-55	Hex-Belt
16	532 1700-38	Blade 3-1 Rh	69	532 1654-82	Shaft Asm W/Lwr Brg Rh Thd CRD
17	872 1406-10	Bolt Carriage 3/8-16 x 1-1/4	84	532 1560-85	Keeper Belt Idler
18	872 1106-08	Bolt Rdhd Sqnk 3/8-16 x 1 Gr5	116	532 1376-44	Bolt Shoulder
19	532 1328-27	Bolt Shoulder 5/16-18 Thd Form	117	532 1339-57	Wheel Gage Donut Wide
20	532 1654-84	Bolt 3/8-24 x 1.25 Gr8 Ptch Lhthd	118	873 9306-00	Nut Centerlock 3/8-16 Unc
21	873 6805-00	Nut Crown Lock 5/16-18	119	819 1214-14	Washer 3/8 x 7/8 x 14 Ga.
22	532 1652-43	Bracket Idler Sprt RR	124	872 1106-12	Bolt Carr Sh 3/8-16 x 1-1/2 Gr5
23	532 1654-46	Bracket Idler Sprt RF	130	872 1105-06	Bolt Rdhdsqnk 5/16-18 Unc x 3/4
24	532 1652-42	Bracket Suspension LF	131	532 1656-61	Chute Bagger CRD 92cm
25	532 1652-44	Bracket Suspension RF	-	532 1307-94	Mandrel Asm Service
26	532 1652-37	Brace Support Susp Frt	-	532 1655-79	Mandrel Asm CRD Lh Threads SVC
27	532 1655-68	Bracket Asm. Susp RR	-	532 1806-44	Deck Mower Complete
28	532 1655-67	Bracket Asm. Susp LR			
30	532 1739-84	Screw Thd Rolling			
31	532 1299-63	Washer Spacer Mower Vented			
32	532 1535-31	Mandrel Pulleys			

**NOTE:** All component dimensions given in U.S. inches  
1 inch = 25.4 mm

www.emc-motors.com

# REPAIR PARTS

TRACTOR- -MODEL NO. CTH155 (HECTH155A), PRODUCT NO. 954 17 00-51  
BAGGER

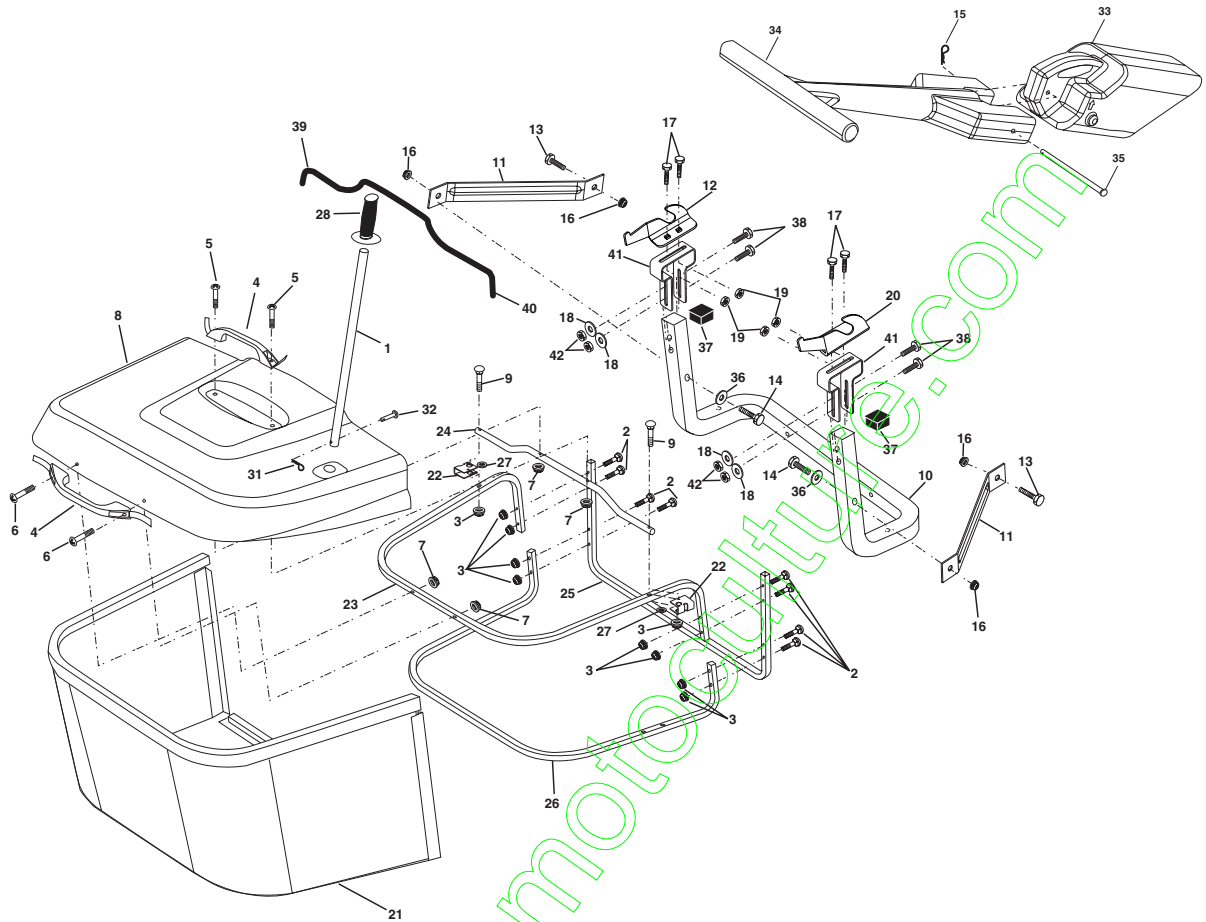

KEY NO.	PART NO.	DESCRIPTION	KEY NO.	PART NO.	DESCRIPTION
1	532 16 52-49	Tube Handle Bagger CRD	22	532 16 57-81	Bracket Side Bagger CRD
2	872 14 04-16	Bolt Carriage 1/4-20 x 2.0 Gr.5	23	532 16 57-82	Tube Upper Bagger CRD
3	532 12 39-76	Nut Lock 1/4 Lge Flg Gr. 5 Zinc	24	532 16 57-83	Tube Pivot Bagger CRD
4	532 16 99-16	Handle Bagger w/Lyrs Blk CRD	25	532 18 01-24	Tube Front Bagger CRD
5	874 98 10-24	Screw Pan Head #10-24 x 1.50 Blk	26	532 16 57-85	Tube Lower Bagger CRD
6	874 98 10-32	Screw Pan Hd	27	532 16 96-92	Bushing Snap Bagger CRD
7	873 40 10-00	Nut Wiz Lock Hex Serr/Hd 10-24	28	532 16 57-87	Grip Handle Black
8	532 18 10-95	Cover Bagger	31	532 12 47-88	Retainer Spring 1" Zinc/Cad
9	872 14 04-18	Bolt Carriage 1/4-20 x 2.25d x Gr.5	32	532 12 68-75	Rivet Rd Hd Drilled 3/8 Dia
10	532 16 96-88	Tube Support Bagger CRD	33	532 16 55-71	Plug Mulcher
11	532 16 57-19	Bracket Support Upper Bag CRD	34	532 16 55-70	Handle Mulcher
12	532 16 96-85	Bracket Horiz Adj Bagger Lh	35	532 16 55-72	Pin Mulcher
13	872 11 06-06	Bolt Rdhd Sht Sqnk 3/8-16 x 3/4	36	819 13 20-16	Washer 13/32 x 1-1/4 x 16 Ga.
14	872 14 06-20	Bolt RDHD SQNK 3/8-16 x 2-1/2 Gr.5	37	532 17 54-01	Plug Support Bagger CRD
15	532 12 46-70	Retainer Spring	38	872 01 05-20	Bolt 5/16-18 x 2-1/2
16	873 90 06-00	Nut Lock Flg 3/8-16 Unc	39	532 18 09-85	Seal Trim
17	872 14 05-06	Bolt Rdhd Sht Sqnk 5/16 -18 Unc x 3/4	41	532 16 96-83	Bracket Pnt Adj Pvt Bagger CRD
18	819 11 12-16	Washer 11/32 x 3/4 x 16 Ga.	42	873 80 05-00	Nut Crownlock 5/16-18 Blk D
19	873 90 05-00	Nut Lock Hex Flange 5/16-18			
20	532 16 96-84	Bracket Horiz Adj Bagger Rh			
21	532 16 57-80	Bag Asm CRD			

**NOTE:** All component dimensions given in U.S. inches  
1 inch = 25.4 mm

# TRACTOR- -MODEL NO. CTH155 (HECTH155A), PRODUCT NO. 954 17 00-51 SCHEMATIC

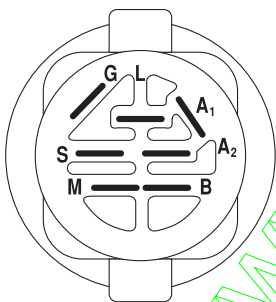
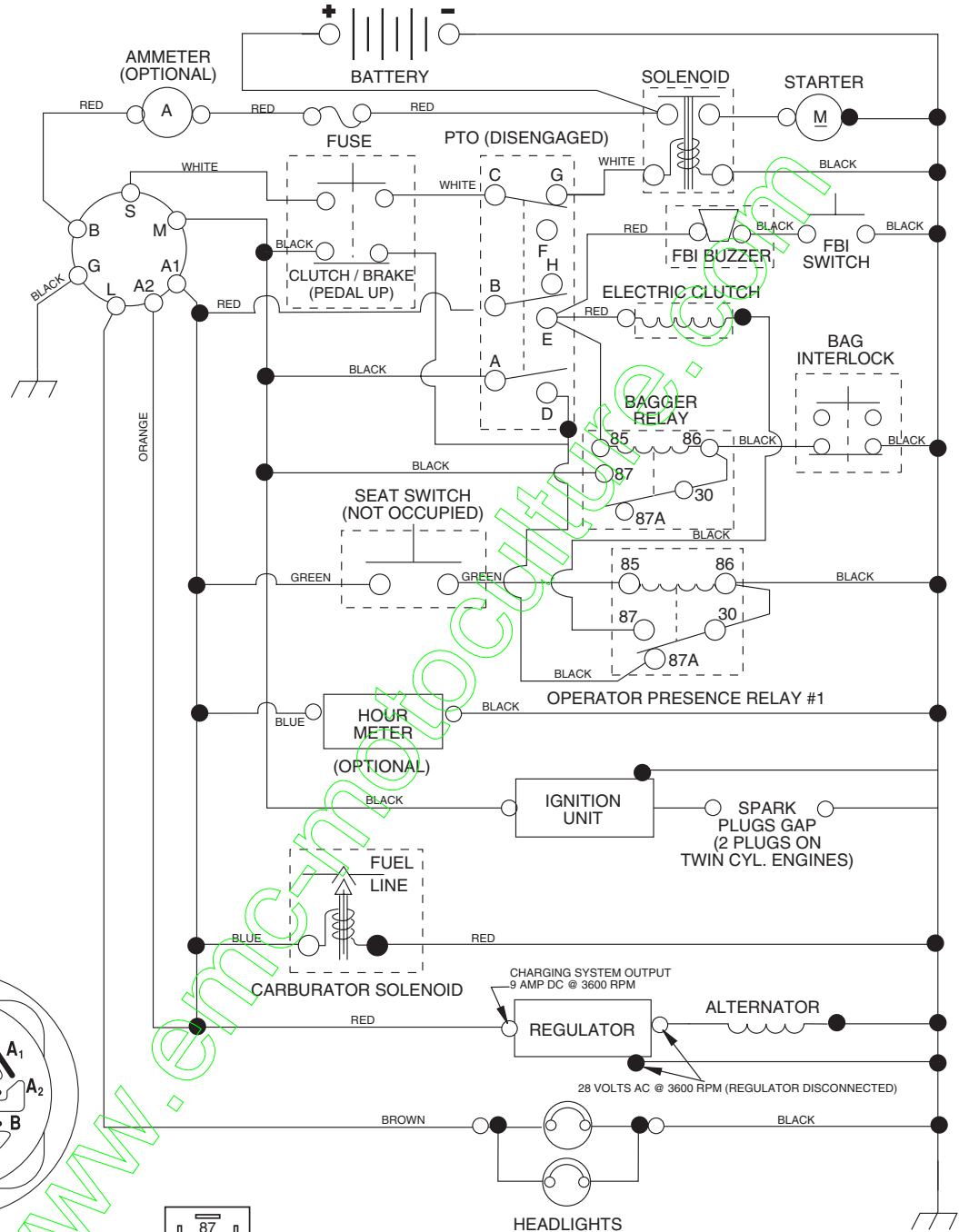

**IGNITION SWITCH**

POSITION	CIRCUIT	"MAKE"
OFF	M+G+A1	NONE
RUN/LIGHT	B+A1	A2+L
RUN	B+A1	NONE
START	B + S + A1	NONE

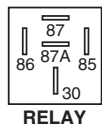

**RELAY**

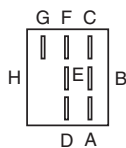

**PTO SWITCH**

POSITION	CIRCUIT
OFF	C + G, B + H
ON	C + F, B + E, A + D

●  
NON-REMOVABLE  
CONNECTIONS

○  
REMOVABLE  
CONNECTIONS

**WIRING INSULATED CLIPS**  
NOTE: IF WIRING INSULATED CLIPS WERE REMOVED FOR SERVICING OF UNIT, THEY SHOULD BE REPLACED TO PROPERLY SECURE YOUR WIRING.