

REPAIR PARTS MANUAL

40" - 12.5 H.P. LAWN TRACTOR

MODEL D3554-020

ONE YEAR LIMITED WARRANTY

For one (1) year from date of purchase by the first consumer for residential use (thirty (30) days commercial use), NOMA Outdoor Products Incorporated warrants that it will replace free of charge, including labor, any original part of any NOMA Outdoor Products Incorporated product found to be defective by any authorized Service Dealer or the factory, except the battery which is warranted for ninety (90) days from date of purchase.

This warranty does not cover engine, transmission, transaxle or differential (these items are covered by their manufacturer's own warranty). This warranty does not cover parts that have failed due to normal wear or parts that have failed subject to misuse or abuse. Transportation of the unit or part to and from an authorized Service Dealer or factory is the responsibility of the owner.

A step by step explanation as to what procedure should be followed for this warranty is:

1. If a part becomes defective, contact the store where the unit was purchased for the name and address of the authorized Service Dealer nearest to you.
2. If you cannot locate an authorized Service Dealer, write Service Department of NOMA Outdoor Products Incorporated for the name and address of the authorized Service Dealer in your area or call the Service Department at 1-901-422-1690.
3. Return the defective product, along with proof of purchase to such authorized Service Dealer for replacement of any defective part where covered by this warranty.

There is no other express warranty. Implied warranties, including those of merchantability and fitness for a particular purpose are limited to one (1) year from date of purchase. Liability for incidental or consequential damages are excluded.

Some states do not allow limitations on how long an implied warranty lasts, so the above limitation may not apply to you. Some states do not allow the exclusion of incidental or consequential damages, so the above exclusion may not apply to you. This warranty gives you specific legal rights, and you may have other rights which vary from state to state.

NOMA Outdoor Products Incorporated

Caller 8000

Jackson, TN 38308-8000

UNIT PARTS AND SERVICE

Fill in and mail the registration card packed with the unit. For service other than covered in this manual, contact an authorized service dealer. A nationwide parts and service organization has been established to provide locally available parts and service. A list of authorized parts distributors has been included in this manual. When ordering repair parts, always give the following information: 1. The Part Name; 2. The Part Number; 3. The Quantity desired; 4. The Full (eight digit) Model Number of the unit. The model number will be found on a plate attached to the unit.



Look for this symbol. It means - ATTENTION! BECOME ALERT! A HAZARD TO OPERATOR, BYSTANDER, PROPERTY OR EQUIPMENT MAY EXIST.

NOMA Outdoor Products Incorporated

Caller 8000

Jackson, TN 38308-8000

Part No. 329057A

51/92



SAFETY RULES

THESE INSTRUCTIONS ARE FOR YOUR PROTECTION. PLEASE READ THEM CAREFULLY.



IMPORTANT

THIS CUTTING MACHINE IS CAPABLE OF AMPUTATING HANDS AND FEET AND THROWING OBJECTS. FAILURE TO OBSERVE THE FOLLOWING SAFETY INSTRUCTIONS COULD RESULT IN SERIOUS INJURY OR DEATH.

I. GENERAL OPERATION:

- Know controls and how to stop quickly.
- Read, understand, and follow all instructions in the manual and on the machine before starting.
- Only allow responsible adults, who are familiar with instructions, to operate the machine.
- Wear safety glasses or eye shields when assembling or operating the machine.
- Do not operate machine when barefooted. Always wear substantial footwear, preferably steel-toed shoes.
- Do not wear loose fitting clothing that could get caught in moving parts.
- Clear the area of objects such as rocks, toys, wire, etc., which could be picked up and thrown by the blade(s).
- Be sure the area is clear of other people before mowing. Stop machine if anyone enters the area.
- Never carry passengers.
- Do not mow in reverse unless absolutely necessary. Always look down and behind before and while backing.
- Be aware of the mower discharge direction and do not point it at anyone. Do not operate the mower without either the entire grass catcher or the guard in place.
- Slow down before turning.
- Never leave a running machine unattended. Always turn off blades, set parking brake, stop engine, and remove keys before dismantling.
- Turn off blade(s) when not mowing.
- Stop engine before removing grass catcher or unclogging chute.
- Mow only in daylight or good artificial light.
- Do not operate the machine while under the influence of alcohol or drugs.
- Watch for traffic when operating near or crossing roadways.
- Use care when mowing around a fixed object to prevent the blade(s) from striking it. Never deliberately run over any foreign object.
- Use extra care when loading or unloading the machine into a trailer or truck.
- Use care when pulling loads or using heavy equipment.
 - a. Use only approved drawbar hitch points.
 - b. Limit loads to those that you can safely control.
 - c. Do not turn sharply. Use care when backing.
 - d. Use counterweight(s), wheel weight or tire chains when suggested in attachment(s) instructions.

II. SLOPE OPERATION:

Slopes are a major factor related to loss-of-control and tip-over accidents, which can result in severe injury or death. *All slopes require extra caution.* If you cannot back up the slope or if you feel uneasy on it, do not mow it.

DO

- Mow up and down slopes, not across.
- Remove obstacles such as rocks, tree limbs, etc.
- Watch for holes, ruts, or bumps. Uneven terrain could overturn the machine. *Tall grass can hide obstacles.*
- Use slow speed. Choose a low gear so that you will not have to stop or shift while on the slope.
- Follow the manufacturer's recommendations for wheel weights or counterweights to improve stability.
- Use extra care with grass catchers or other attachments. These can change the stability of the machine.
- Keep all movement on the slopes *slow* and *gradual*. Do not make sudden changes in speed or direction.
- Avoid starting or stopping on a slope. If tires lose traction, turn off the blade(s) and proceed slowly *straight* down the slope.

DO NOT

- Do not turn on slopes unless necessary, and then slowly and gradually downhill, if possible.
- Do not mow near drop-offs, ditches or embankments. The

mower could suddenly turn over if a wheel is over the edge of a cliff or ditch, or if an edge caves in.

- Do not mow on wet grass. Reduced traction could cause sliding.
- Do not try to stabilize the machine by putting your foot on the ground.
- Do not use grass catcher on steep slopes.

III. CHILDREN:

Tragic accidents can occur if the operator is not alert to the presence of children. Children are often attracted to the machine and the mowing activity. *Never* assume that children will remain where you last saw them.

- Keep children out of the mowing area and under the watchful care of another responsible adult.
- Be alert and turn machine off if children enter the area.
- Before and when backing, look behind and down for small children.
- Never carry children. They may fall off and be seriously injured or interfere with safe machine operation.
- Never allow children to operate the machine.
- Use extra care when approaching blind corners, shrubs, trees, or other objects that may obscure vision.

IV. SERVICE:

- Use extra care in handling gasoline and other fuels. They are flammable and vapors are explosive.
 - a. Use only an approved container.
 - b. Never remove gas cap or add fuel with the engine running. Allow engine to cool before refueling. Do not smoke.
 - c. Never refuel the machine indoors.
 - d. Never store the machine or fuel container inside where there is an open flame, such as in a water heater.
- Check fuel supply before each use allowing space for expansion as the heat of the engine and/or sun can cause gasoline to expand and overflow the tank.
- Use extra care when handling battery acid. Acid contact with skin may cause severe burns. Eye contact may cause blindness.
- Use extra care when servicing the battery. Explosive gas is produced in the battery. Do not service the battery while smoking or near an open spark or flame. This may cause the battery to explode causing serious injury.
- Never run a machine inside a closed area. Exhaust fumes contain CARBON MONOXIDE, an ODORLESS and DEADLY GAS.
- Keep nuts and bolts, especially blade attachment bolts, tight and keep equipment in good condition.
- Never tamper with safety devices. Check their operation regularly.
- Do not change the engine governor settings or overspeed engine.
- Reduce fire hazards. Keep machine free of grass, leaves, or other debris build-up. Clean up oil or fuel spillage. Allow machine to cool before storing.
- Stop and inspect the equipment if you strike an object. Repair, if necessary, before restarting.
- Never make adjustments or repairs with the engine running.
- Grass catcher components are subject to wear, damage, and deterioration, which could expose moving parts or allow objects to be thrown. Frequently check components and replace with manufacturer's recommended parts, when necessary.
- Mower blade(s) are sharp and can cut. Wrap the blade(s) or wear gloves, and use extra caution when servicing them.
- Check brake operation frequently. Adjust and service as required.



LOOK FOR THIS SYMBOL TO POINT OUT IMPORTANT SAFETY PRECAUTIONS. IT MEANS-- ATTENTION!!! BECOME ALERT!!! YOUR SAFETY IS INVOLVED.

OWNER'S INFORMATION

Record the following information about your unit so that you will be able to provide it in case of loss or theft.

MODEL NUMBER: - (Enter complete 8 digit number from model plate on unit)
PURCHASE DATE: ___ / ___ / ___ CODE NO.: _____ SERIAL NO.: _____
DEALER'S NAME AND ADDRESS: _____
CITY: _____ STATE: _____ TELEPHONE: _____

CONTENTS OF SHIPPING CARTON

- 1 - Lawn Tractor with 40 inch Mower Deck
- 1 - Operator's Manual
- 1 - Repair Parts Manual
- 1 - Engine Manual
- 1 - Steering Wheel (see Note)
- 1 - Seat (see Note)
- 1 - Bag of Assembly Parts Containing (see Note):
 - 4 - 5/16 x 3/4 inch Hex Head Screws
 - 4 - 5/16 inch Split Lockwashers
 - 4 - 11/32 inch Flatwashers
 - 1 - Roll Pin
 - 1 - Steering Sleeve

NOTE: Refer to page 28 (Customer Assembly Parts) for more detailed description.

TOOLS REQUIRED FOR ASSEMBLY

- 2 - 7/16 inch Wrenches (or adjustable wrench)
- 1 - 1/2 inch Wrench (or adjustable wrench)
- 1 - Small Phillips Screwdriver with a 1/4 inch shank
- 1 - Hammer

HOW TO MEASURE SCREW SIZE (5/16 x 1 1/2 INCH)

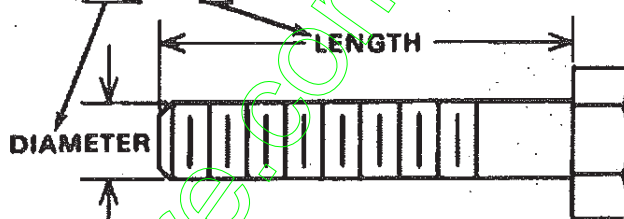

DANGER



This lawn tractor can be dangerous if carelessly used.

Read your Operator's Manual thoroughly before operating your lawn tractor.

Always wear safety glasses or eye shields while assembling or operating your lawn tractor.

DO NOT carry passengers at any time.

Keep your hands, feet, hair and loose clothing away from the discharge area, the underside of the mower deck or any moving parts while the engine is running.

DO NOT allow children or young teenagers to operate or be near your lawn tractor while it is operating.

ALWAYS GIVE THE FOLLOWING INFORMATION WHEN ORDERING REPAIR PARTS:

1. The PART NUMBER; 2. The PART NAME; 3. QUANTITY DESIRED; 4. The MODEL NUMBER (As shown on Model Plate).

SEND PART ORDERS AS PER INSTRUCTIONS ON THE FRONT PAGE.

DO NOT USE KEY NUMBERS WHEN ORDERING REPAIR PARTS, ALWAYS USE PART NUMBERS.

All replacement parts will be supplied in current production colors or in a neutral color.

A handling fee is applicable to small parts orders.

YOUR UNIT IS RIGHT HAND (RH) OR LEFT HAND (LH) AS YOU STAND BEHIND IT.

40" LAWN TRACTOR MODEL D3554-020

CHASSIS & HOOD ASSEMBLY

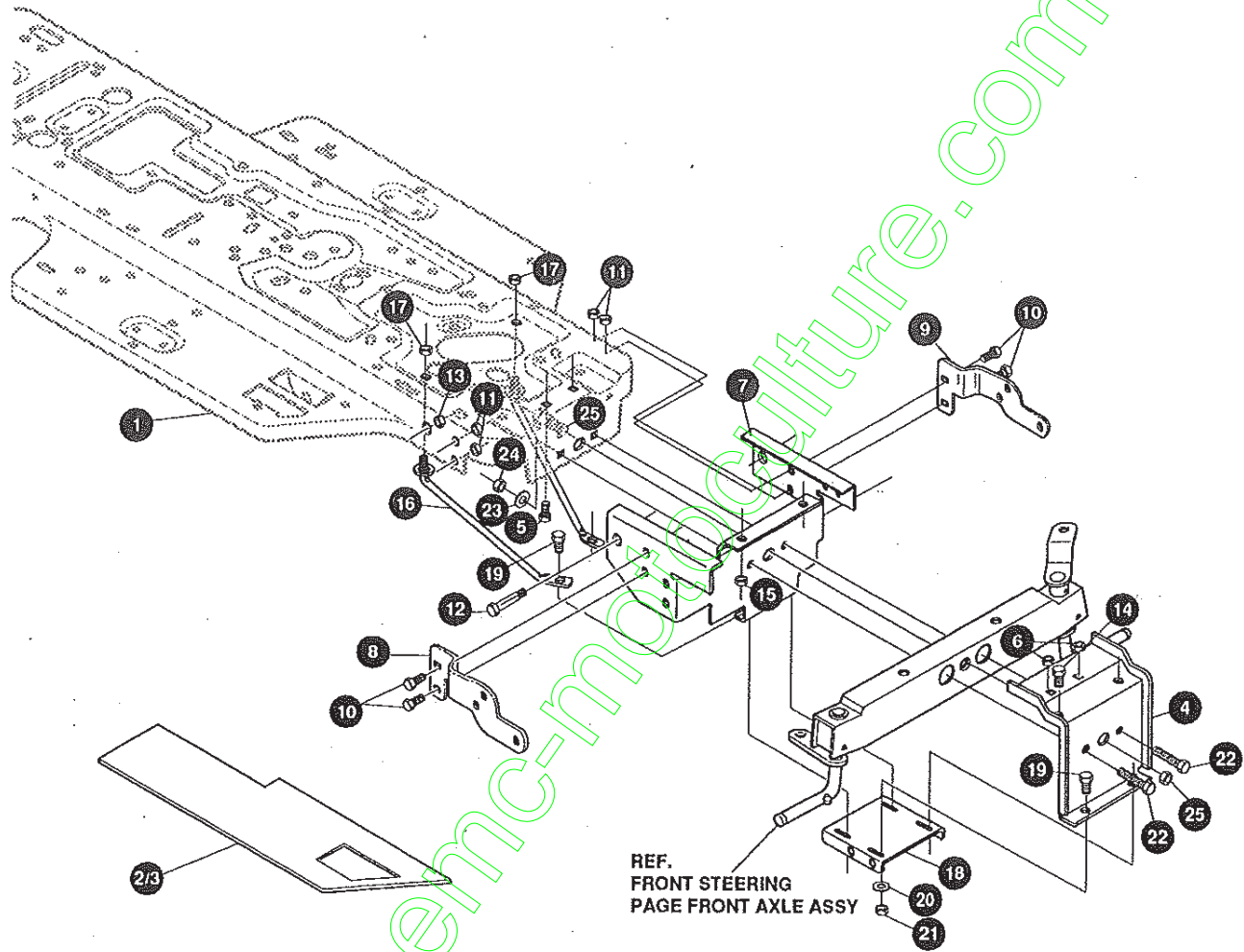

NOTE: ALWAYS USE ORIGINAL EQUIPMENT PARTS. Use of service/replacement parts other than original equipment parts may void your warranty.

ALL UNNUMBERED ITEMS ARE INTERCHANGEABLE WITH OPPOSITE SIDE

324739A

40" LAWN TRACTOR MODEL D3554-020

KEY#	PART#	DESCRIPTION	QTY.
1.	321997-860	MP FRAME,MAIN SF RIDER	1
2.	302917	FOOT PAD, LH SF WIDE	1
3.	302916	FOOT PAD, RH SF WIDE	1
4.	324815-860	BRACKET, SF FRNT XL UP SUPP	1
5.	57081	BOLT, 3/8-16X.75 CARR GR5Z	2
6.	1499	NUT, 3/8-16 REGHXCTRLK Z	2
7.	324816-860	BRACKET, SF FRNT XL LO SUPP	1
8.	325746-853	MP BRACKET GRILLE RH G17 EXTSE	1
9.	325747	MP BRACKET GRILLE LH G17 EXTSE	1
10.	328154	SCREW, 5/16-18X1.00 HHC	4
11.	55273	NUT, 5/16-18HXWDFLLK	4
12.	123567	SCREW, 7/16-20X1.00 HHC GR2	2
13.	1282	NUT, 7/16-20 WDFLLK	2
14.	122007	SCREW, 5/16-18X.75 HHC	2
15.	1498	NUT, 5/16-18 REGHEXCTRLK	2
16.	326297	ROD, SUPPORT FRAME SF	2
17.	1499	NUT, 3/8-16 REGHXCTRLK	2
18.	326296-853	MW BRACKET FRONT HANGER	1
19.	180077	SCREW, 5/16-18X.75 HHC GR5	4
20.	120393	WASHER, FLAT .344X.69X.035	4
21.	1498	NUT, 5/16-18 REGHEXCTRLK	4
22.	122201	SCREW, 3/8-16X2.75 HHC GR2	2
23.	2483	WASHER, .391DX1.25DX.07 BELLVIL	2
24.	1499	NUT, 3/8-16 REGEHXCTRLK	2
25.	29616	BOLT, .625X1.890HHSH 1/2-20	1
26.	274654	NUT, 1/2-20 REGHXCTRLK	1
27.	329057	PARTS MANUAL	1
28.	329058	OPERATOR'S MANUAL (ENGLISH)	1
29.	329059	OPERATOR'S MANUAL (FRENCH)	1
30.	329060	OPERATOR'S MANUAL (GERMAN)	1

40" LAWN TRACTOR MODEL D3554-020

CHASSIS & HOOD ASSEMBLY

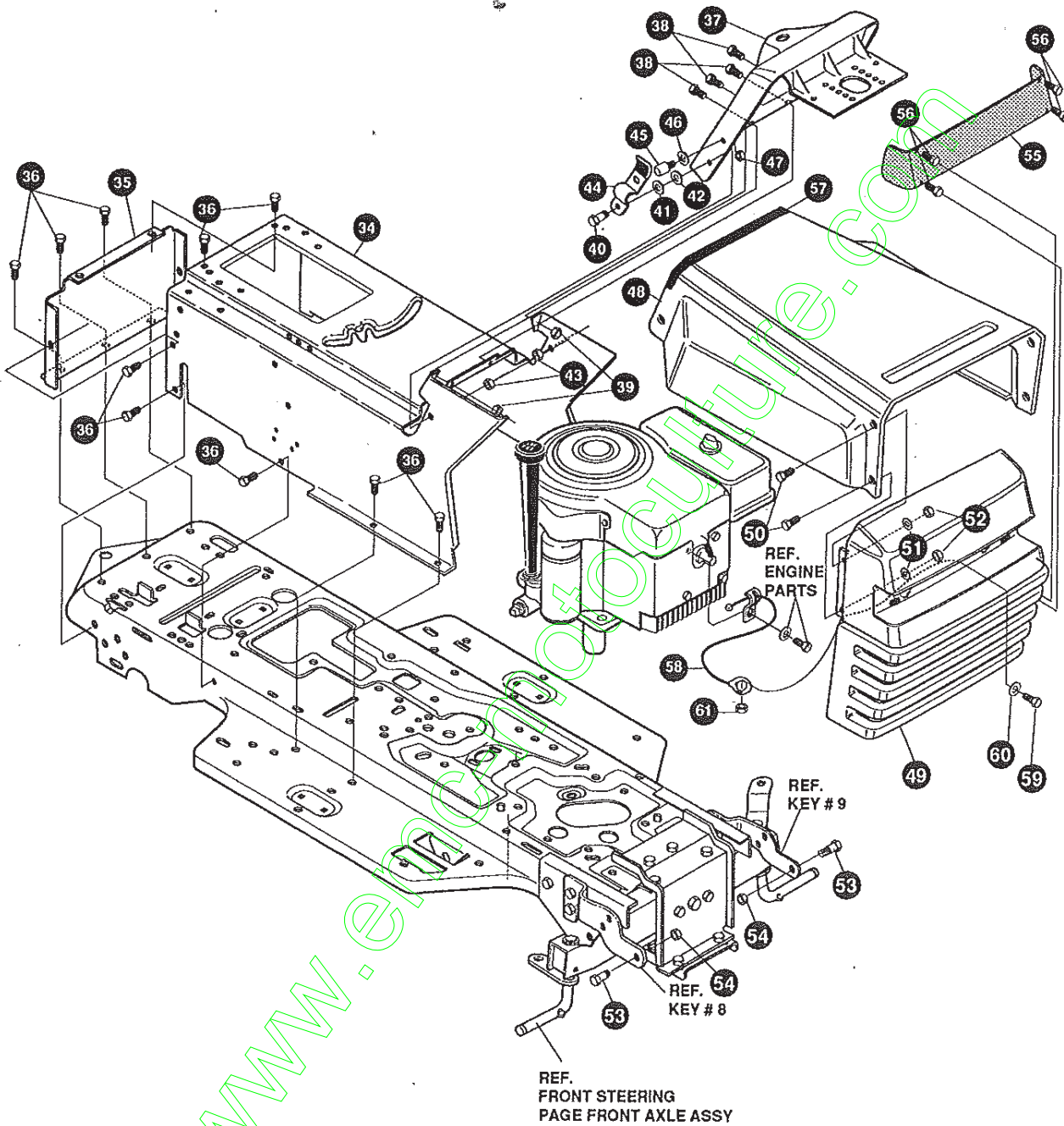

NOTE: ALWAYS USE ORIGINAL EQUIPMENT PARTS. Use of service/replacement parts other than original equipment parts may void your warranty.

ALL UNNUMBERED ITEMS ARE INTERCHANGEABLE WITH OPPOSITE SIDE

324739A

40" LAWN TRACTOR MODEL D3554-020

KEY#	PART#	DESCRIPTION	QTY.
34.	314491-860	MP CONSOLE, SF DYNA FNDR SHFT	1
35.	56235-860	MP CONSOLE, REAR COVER	1
36.	995346	SCREW, 1/4-20X.50 WAHHATP	15
37.	320466-860	MP DASH, SF NOMA DYNA STYLING	1
38.	995338	SCREW, 1/4-20X.63 HHWATAP	6
39.	50352	NUT, 1/4-20 WDFLLK TOPLOCK	4
40.	8482	BOLT, .375X.156 HHSH 5/16-18	2
41.	120394	WASHER, FLAT .406X.81X.065	2
42.	120393	WASHER, FLAT .344X.69X.065	2
43.	1498	NUT, 5/16-18 REGHEXCTRLK	2
44.	57159	LATCH, .94WDX.047 ASSY HOOD	1
45.	53446	PIN, 5/16-18 HOOD LATCH GR2	2
46.	138538	WASHER, REGINTLK .320X.61X.03	2
47.	45174	NUT, 5/16-18 HEXWDFFLK WHIZ	2
48.	328278	HOOD, SF	1
49.	325401	GRILLE G17	1
50.	274672	SCREW, 1/4-20X.63 WAHHC GR2	4
51.	120392	WASHER, FLAT .281X.63X.065	4
52.	1502	NUT, 1/4-20 REGHEXCTRLK	4
53.	36149	BOLT, .375X.500 HHSH 5/16-18	2
54.	1498	NUT, 5/16-18 REGHEXCTRLK	2
55.	302333	LENS SMOKED W/TAB NO LOGO	1
56.	57796	SCREW, #6X.50 PLASTITE/HI-LO	4
57.	56304	EDGING, WIDE BLK	25"
58.	311094	LANYARD, HOOD	1
59.	121887	SCREW, 1/4-20X.75 HHC	1
60.	120392	WASHER, FLAT .281X.63X.065	1
61.	1502	NUT, 1/4-20 REGHEXCTRLK	1

www.emc-motorsculture.com

40" LAWN TRACTOR MODEL D3554-020

CHASSIS & HOOD ASSEMBLY

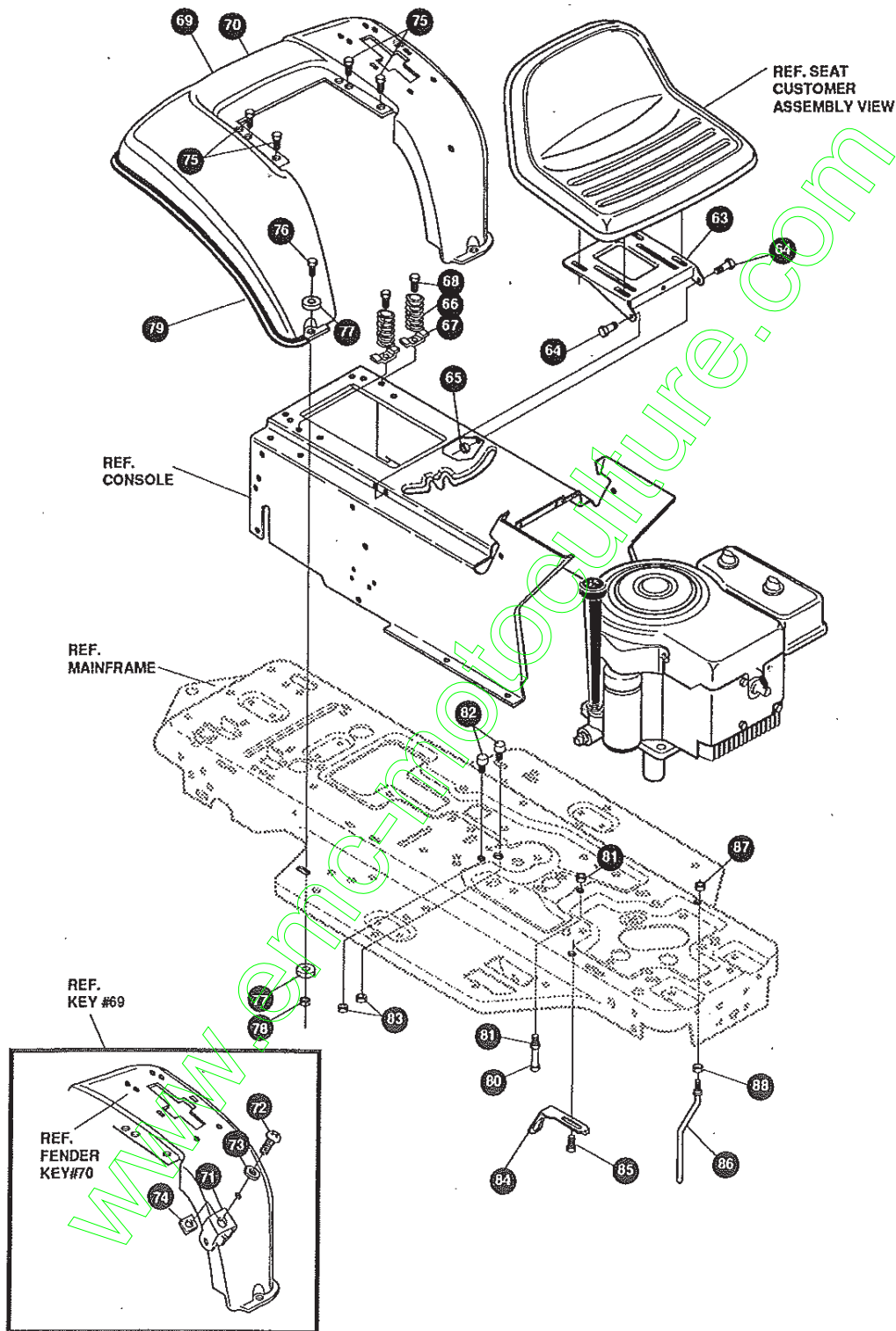

NOTE: ALWAYS USE ORIGINAL EQUIPMENT PARTS. Use of service/replacement parts other than original equipment parts may void your warranty.

ALL UNNUMBERED ITEMS ARE INTERCHANGEABLE WITH OPPOSITE SIDE

324739A

40" LAWN TRACTOR MODEL D3554-020

KEY#	PART#	DESCRIPTION	QTY.
63.	58367-853	MP PLATE, SEAT F5 SF,LF	1
64.	20507	BOLT, .437X.156 HSH 5/16-18	2
65.	1498	NUT, 5/16-18 REGHEXCTRLK	2
66.	56220	SPRING, 1.43X2.38X.162 COM SEAT	2
67.	1341	ML CLAMP SPRING 1.17 ID	2
68.	995346	SCREW, 1/4-20X.50 WAHTAP	2
69.	^	MP FENDER F-5 SF	1
70.	321157-860	MP FENDER F-5 SF S.O.C./L.O.F.	1
71.	9239	ML CLEVIS	1
72.	439455	SCREW, 5/16-18X.56 PHPNMA	1
73.	301551	WASHER, .344IDX1.50DX.09	1
74.	120373	NUT, 5/16-18 SQ.	1
75.	995346	SCREW, 1/4-20X.50 WAHTAP	4
76.	122007	SCREW, 5/16-18X.75 HHC	2
77.	446363	WASHER .375X.88X.082	4
78.	1498	NUT, 5/16-18 REGHEXCTRLK	2
79.	55023	TRIM, STRIP, BLACK—SMALL. WADH	75"
80.	427342	SCREW, 3/8-16X6.50 HHC	1
81.	1499	NUT, 3/8-16 REGHXCTRLK	2
82.	53446	PIN, 5/16-18 HOOD LATCH	2
83.	271184	NUT, 5/16-18 HEXKEPS	2
84.	302610-853	MP BRACKET, SWITCH MOUNTING	1
85.	995346	SCREW, 1/4-20X.50 WAHTAP	1
86.	50653	GUIDE, BELT	1
87.	41529	NUT, 3/8-16 HXCTRLKJAM	1
88.	271190	NUT, 3/8-16 HEXKEPS	1

^ ORDER INDIVIDUAL PARTS.

www.emc-motoculture.com

40" LAWN TRACTOR MODEL D3554-020

MOWER SUSPENSION

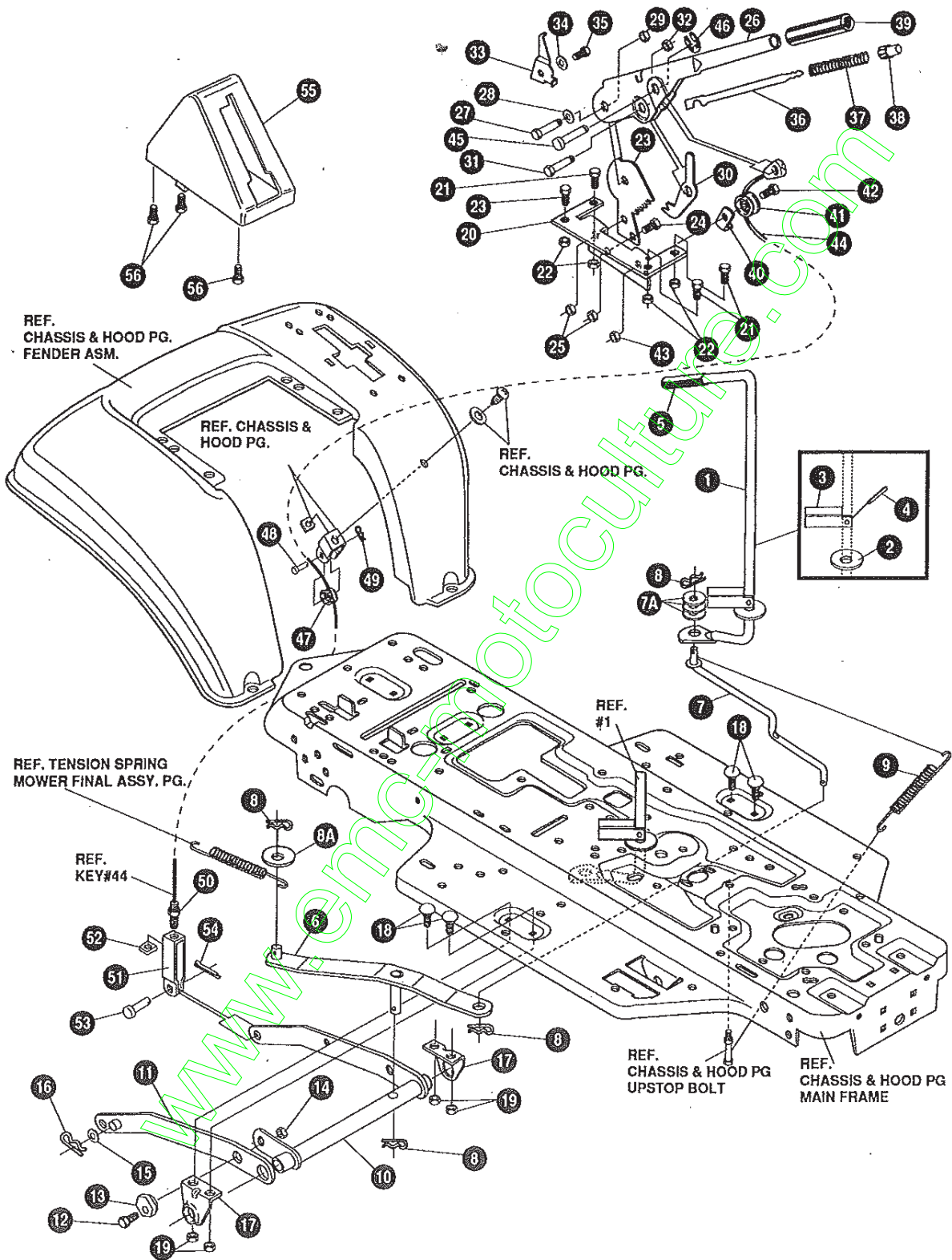

NOTE: ALWAYS USE ORIGINAL EQUIPMENT PARTS. Use of service/replacement parts other than original equipment parts may void your warranty.

ALL UNNUMBERED ITEMS ARE INTERCHANGEABLE WITH OPPOSITE SIDE

324784B

40" LAWN TRACTOR MODEL D3554-020

KEY#	PART#	DESCRIPTION	QTY.
1	3255911	HANDLE, RH PTO NOMA DASH SF	1
2	22265	WASHER, FLAT .515X1.38X.119PL	1
3	305225	ML STOP, PTO ENGAGEMENT	1
4	326386	PIN, SPRING. 187DIA X1.00LG HVPL	1
5	46478	GRIP, HAND .50ID 3.37 LG BLK	1
6	325587-853	WS STRAP ASSY, PTO BELCRANK	1
7	325590	ROD, BELCRANK LINK	1
7A	274517	FLAT WASHER .406X.73X.063	3
8	8260	HAIR PIN	4
8A	25210	FLAT WASHER, .392X1.25X.09	1
9	325802	SPRING, .63X7.75X.0897 TENSION	1
10	326114-853	WP LIFT ASSY, LH	1
11	325130-853	WP LIFT ASSY, RH	1
12	180079	SCREW, 5/16 18X1.00 HHC GR5Z	1
13	58247	NUT, ADJUST	1
14	1498	NUT, 5/16-18 REGHEXCTRLK	1
15	417098	WASHER, FLAT .5331X1.06X.063Z	2
16	8260	PIN, HAIR .091 DIA X1.66LG	2
17	325495-853	MP BRACKET, REAR HANG SUSP	2
18	126211	BOLT, 5/16-18X.63 CARR GR2Z	4
19	1498	NUT, 5/16-18 REGHEXCTRLK	4
20	313926	MF BRACKET, HEIGHT ADJUST	1
21	180077	SCREW, 5/16-18X .75 HHC GR5Z	4
22	1498	NUT, 5/16-18 REGHEXCTRLK	4
23	301238	QUADRANT, HEIGHT ADJUST	1
24	180077	SCREW, 5/16-18X .75 HHC GR5Z	2
25	1498	NUT, 5/16-18 REGHEXCTRLK	2
26	322292-853	MP HANDLE, LIFT SHORT(30" S.F.)	1
27	300171	BOLT, .500X .270 HSSH 5/16-18Z	1
28	996418	WASHER, FLAT .506X .75X.024Z	1
29	44108	NUT, 5/16-18 HWDFLCTRLK	1
30	301239	HF PAWL, SQUARE HTRR955	1
31	300171	BOLT, .500X .270 HSSH 5/16-18Z	1
32	44108	NUT, 5/16-18 HWDFLCTRLK	1
33	9435	ML POINTER	1
34	138479	WASHER, EXLK .195X.41X.03Z	1
35	35287	SCREW, #8-32X .38 HHWATAPGR2	1
36	303027	ROD, ACTUATOR-SHORT	1
37	58326	SPRING, HEIGHT ADJUST	1
38	58325	KNOB, HEIGHT ADJ PUSH BUTTON	1
39	58329	GRIP, .750 OD W/ HOLE BLACK	1
40	9149	ML CABLE RETAINING BRACKET	1
41	48306	PULLEY, POWDER METAL	1
42	58336	BOLT, .375X .375 HSSH 1/4-20	1
43	1502	NUT, 1/4-20 REGHEXCTRLK	1
44	321430	CABLE, LIFT 21.50-30 " S.F.	1
45	300310	PIN, CLEVIS .310 DIA + .475 LG ZPL	1
46	300311	RING, RET E .31X .25TRUX5133-31	1
47	48306	PULLEY, POWDER METAL	1
48	300317	PIN, CLEVIS .375 DIA. X .81 LG	1
49	8260	PIN, HAIR .091 DIA. X 1.66 LG	1
50	120375	NUT, 1/4-20 REGHEX	1
51	9405	ML CLEVIS, LIFT CABLE	1
52	120372	NUT, 1/4-20 REGSQ	1
53	39522	PIN, CLEVIS .312 X .812	1
54	121222	PIN, COTTER .090/.086X.75LG	1
55	300335	LIFT COVER-39" F5	1
56	300340	SCREW, #10 X .75 HHPLAST BLK	3

40" LAWN TRACTOR MODEL D3554-020

STEERING ASSEMBLY

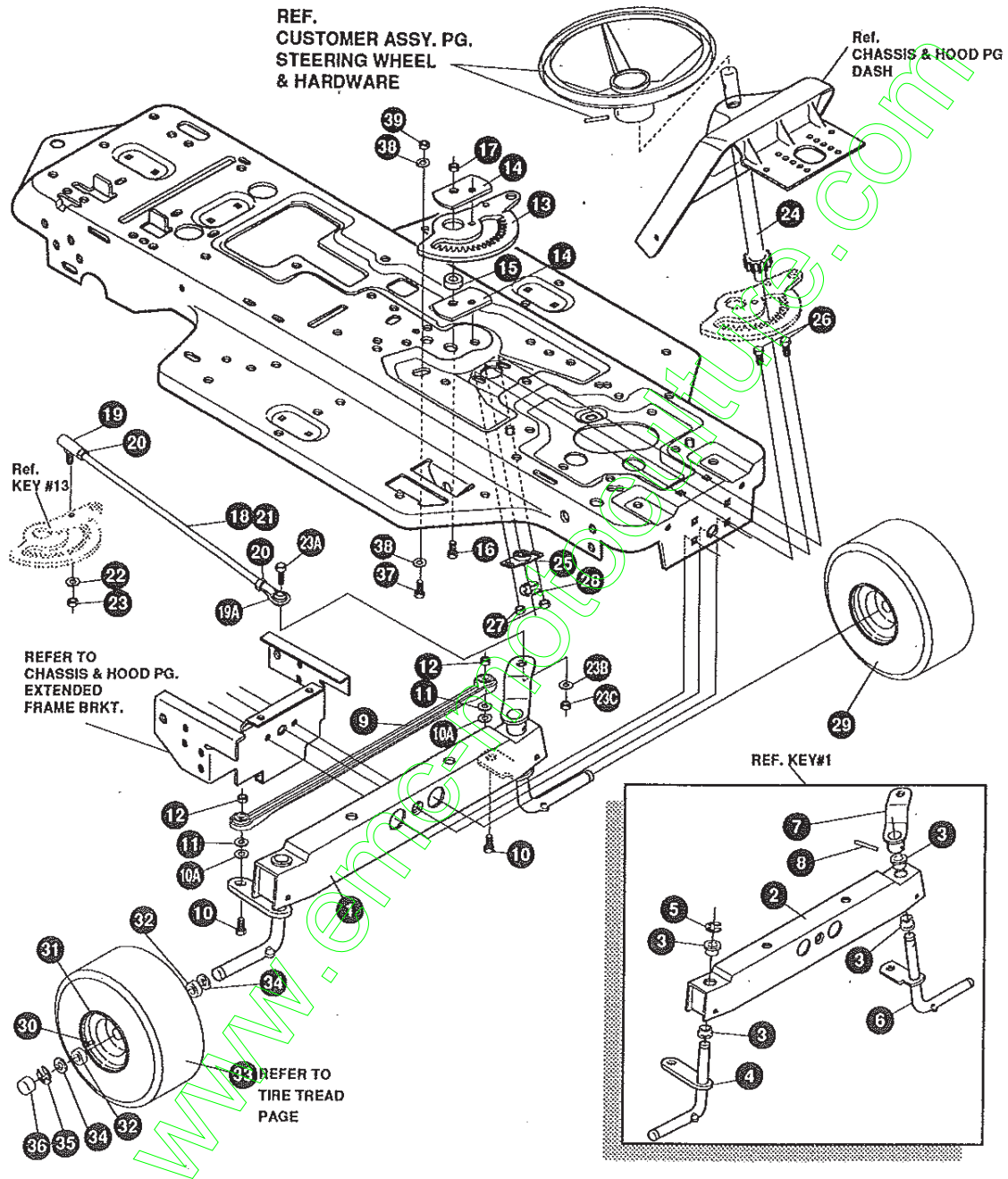

NOTE: ALWAYS USE ORIGINAL EQUIPMENT PARTS. Use of service/replacement parts other than original equipment parts may void your warranty.

ALL UNNUMBERED ITEMS ARE INTERCHANGEABLE WITH OPPOSITE SIDE

324817C

40" LAWN TRACTOR MODEL D3554-020

KEY#	PART#	DESCRIPTION	QTY.
1.	^	FRONT AXLE ASSEMBLY SF	1
2.	312280	AXLE FRONT	1
3.	50546	BEARING FLANGE	4
4.	310368	SPINDLE,RH	1
5.	36625	RING,RETEX	1
6.	310367	SPINDLE,LH	1
7.	327620-853	ARM,ASSY, SF 4WS FRT. STEER	1
8.	454565	PIN,SPRING	1
9.	302688	TIE ROD	1
10.	120918	SCREW, 3/8-16X1.50 HHC	2
10A.	327611	WASHER, FLAT .391 x 1.00 x .194	2
11.	120382	WASHER, .393X.68X.10 REGSPTLK	2
12.	1499	NUT, 3/8-16 REGHCTRLK	2
13.	324752	SECTOR GEAR	1
14.	327833	PLATE, SECTOR	2
15.	324753	BUSHING, SECTOR	1
16.	180124	SCREW, 3/8-16X1.25 GR5	1
17.	1499	NUT 3/8-16 REGHX CTRLK	1
18.	326432	DRAG LINK ASSEMBLY	1
19.	57158	BALL JOINT	1
19A	304260	BALL JOINT	1
20.	124925	NUT, 3/8-24 REGHEXJAM	2
21.	325228	DRAG LINK	1
22.	120382	WASHER, EGSPTLK	1
23.	120369	NUT, 3/8-24 REGHEX	1
23A	122145	SCREW, 3/8-16x1.25 HHC	1
23B	120382	WASHER, EGSPTLK	1
23C	120377	NUT, 3/8-16 REGHX	1
24.	327834	STEERING SHAFT	1
25.	325692	BRNG FLANGE	1
26.	326505	SCR 1/4-20X.75	2
27.	46931	NUT 1/4-20 WDFL MAC LOCK	2
28.	20864	RING,RETEX .39X.04TRU5133	1
29.	^	ASSEMBLY, TIRE & RIM	2
30.	24167	VALVE STEM	1
31.	39829	WHEEL W/BEARING	1
32.	314416	BEARING, 1.380DX.753ID FLANGE	2
33.		REFER TO TIRE TREAD PAGE	
34.	642	WASHER,FLAT .755X1.31X.075	4
35.	36625	RING,RETEX .57X.05	2
36.	40394	HUB CAP	2
37.	122145	SCREW, 3/8-16X1.25	1
38.	120394	WASHER, FLAT	2
39.	44374	NUT, 3/8-16 HXWDFLLK	1

^ ORDER INDIVIDUAL PARTS.

40" LAWN TRACTOR MODEL D3554-020

MOTION DRIVE ASSEMBLY

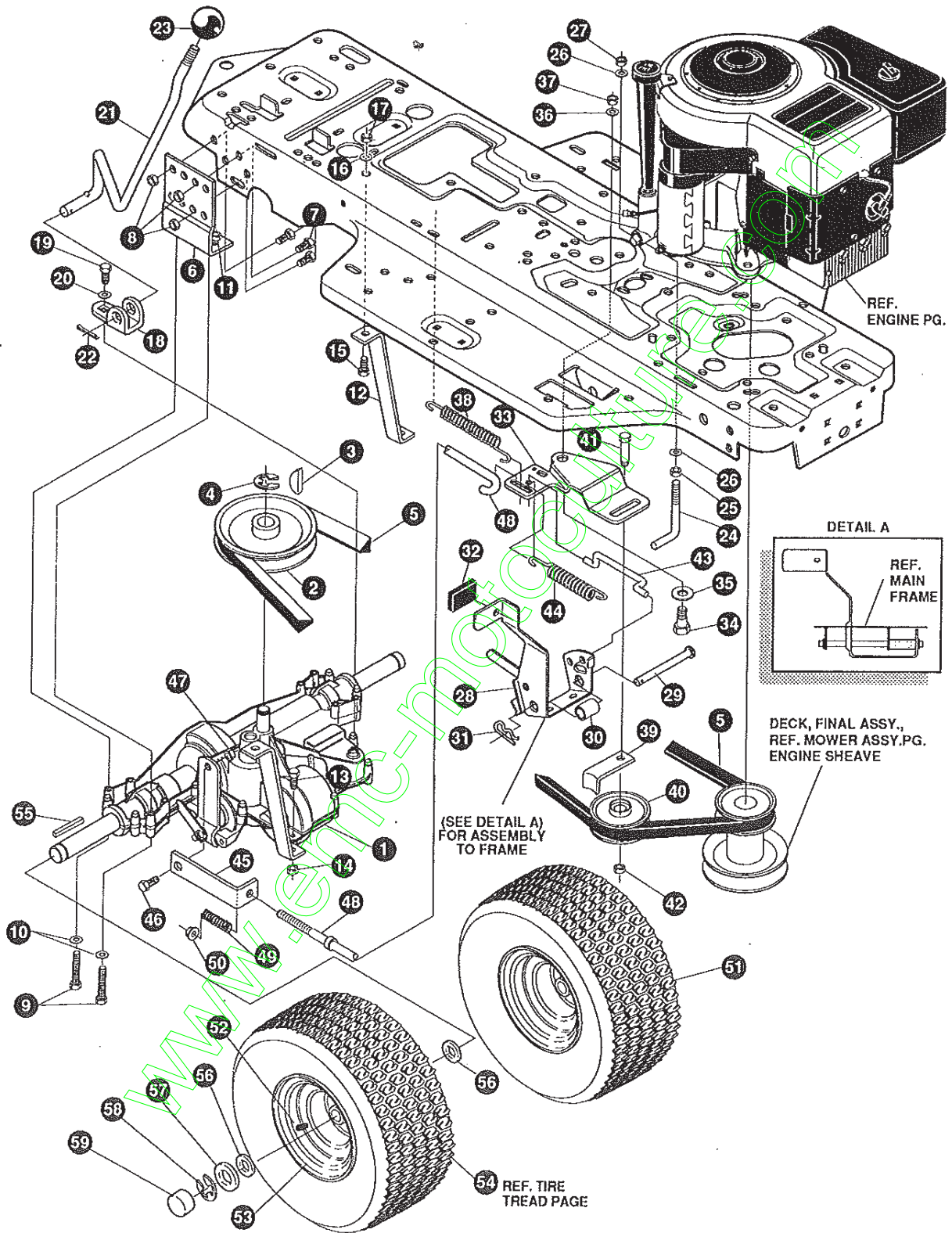

NOTE: ALWAYS USE ORIGINAL EQUIPMENT PARTS.
Use of service/replacement parts other than original equipment parts may void your warranty.

**ALL UNNUMBERED
ITEMS ARE INTERCHANGEABLE
WITH OPPOSITE SIDE**

326632A

40" LAWN TRACTOR MODEL D3554-020

KEY#	PART#	DESCRIPTION	QTY.
1.	*	TRANSAXLE P-940-5SP SF FER	1
2.	302745	PULLEY, IDLER V4L 6.60	1
3.	3021	KEY, WDRF 606 .750X.187X.312	1
4.	22053	RING, RETEX .58X.035TRU5100-62	1
5.	54758	BELT, V 4L 82.00 SF DRIVE	1
6.	326615-853	MP BRACKET,TRANSAXLE 40,43 EXT.	2
7.	180075	SCREW, 5/16-18X .63 HHC	6
8.	1498	NUT, 5/16-18 REGHEXCTRLK	6
9.	180089	SCREW, 5/16-18X2.25 HHC	4
10.	120393	WASHER, FLAT .344X .69X.065	4
11.	1498	NUT, 5/16-18 REGHEXCTRLK	4
12.	323213	MF BRACKET, T/A TORQ. 915 S/F	1
13.	180087	SCREW, 5/16-18X2.00 HHC	1
14.	1498	NUT, 5/16-18 REGHEXCTRLK	1
15.	122017	SCREW, 5/16-18X1.00 HHC	1
16.	138485	WASHER, EXLK .320X.61X.03	1
17.	1498	NUT, 5/16-18 REGHEXCTRLK	1
18.	12616	MH BRACKET, SHIFT P920-3SP	1
19.	56255	SCREW, 1/4-28X .75 NYLHHC	1
20.	57157	WASHER, .750X.250 SP-TRANSAXLE	1
21.	313934	LEVER, SHIFT 915 T/A S/F	1
22.	137185	PIN, COTTER .125 DIA X1.00LG	1
23.	55514	KNOB, ROUND 1.50 DIA BLACK	1
24.	49896	MF BELT GUIDE	1
25.	271184	NUT, 5/16-18 HEXKEPS	1
26.	120393	WASHER, FLAT .344X .69X.065	2
27.	1498	NUT, 5/16-18 REGHEXCTRLK	1
28.	302603-853	SF ASSY,BRAKE PEDAL S.F.	1
29.	319676	PIN,CLEVIS .5 DIA, 4.87LG,ZN PL	1
30.	302601	SPACER, SLEV .53 X .62X1.406	1
31.	56180	PIN, HAIR .091 DIA X1.62LG	1
32.	48761	PAD,CLUTCH/BRAKE PEDAL	1
33.	321969	MF IDLER ARM BRKT TRACTION SF	1
34.	41890	BOLT, .625X .218 HHSH 5/16-18Z	1
35.	4107	WASHER, FLAT .635X1.31X.07	1
36.	45602	WASHER, FLAT .333X .87X.119	1
37.	1498	NUT, 5/16-18 REGHEXCTRLK	1
38.	327867	SPRING,3/4 ODX6.75X.091 TENSIO	1
39.	39659	MF RETAINER,BELT	1
40.	35374	PULLEY, IDLER V4L 3.06X .62	1
41.	45892	BOLT, 3/8-16X1.50 CARR	1
42.	1499	NUT, 3/8-16 REGHXCTRLK	1
43.	43980	ROD, .268 DIA CLUTCH	1
44.	50562	SPRING,3/8ODX1.625X.055 TENSIO	1
45.	323210	BRACKET, TRACTION BRAKE S/F	1
46.	46824	BOLT, .500X .188 HHSH 5/16-18Z	1
47.	1498	NUT, 5/16-18 REGHEXCTRLK	1
48.	323214	ROD, BRAKE 915 T/A SF	1
49.	313881	SPRING, CLUTCH .625 OD	1
50.	50352	NUT, 1/4-20 WDFLLK TOPLOCK	1
51.	^	TIRE & RIM, PU 20X8X8 TURWHI	2
52.	24167	VALVE STEM	1
53.	326362	WHEEL&HUB ASSY 20X8 WHITE	1
54.		REFER TO TIRE TREAD PAGE	
55.	52928	KEY, SQUARE .187SQX2.25LG	2
56.	642	WASHER, FLAT .755X1.31X.075	4
57.	42815	WASHER, FLAT .755X1.53X.07	2
58.	36625	RING, RETEX .57X.05TRU5133-75	2
59.	40394	HUB CAP, 1.500ID X 7/8LG	2

^ ORDER INDIVIDUAL PARTS.

* CONTACT YOUR NEAREST TRANSAXLE DEALER FOR PARTS AND SERVICE.

40" LAWN TRACTOR MODEL D3554-020

ENGINE & CONTROL ASSEMBLY

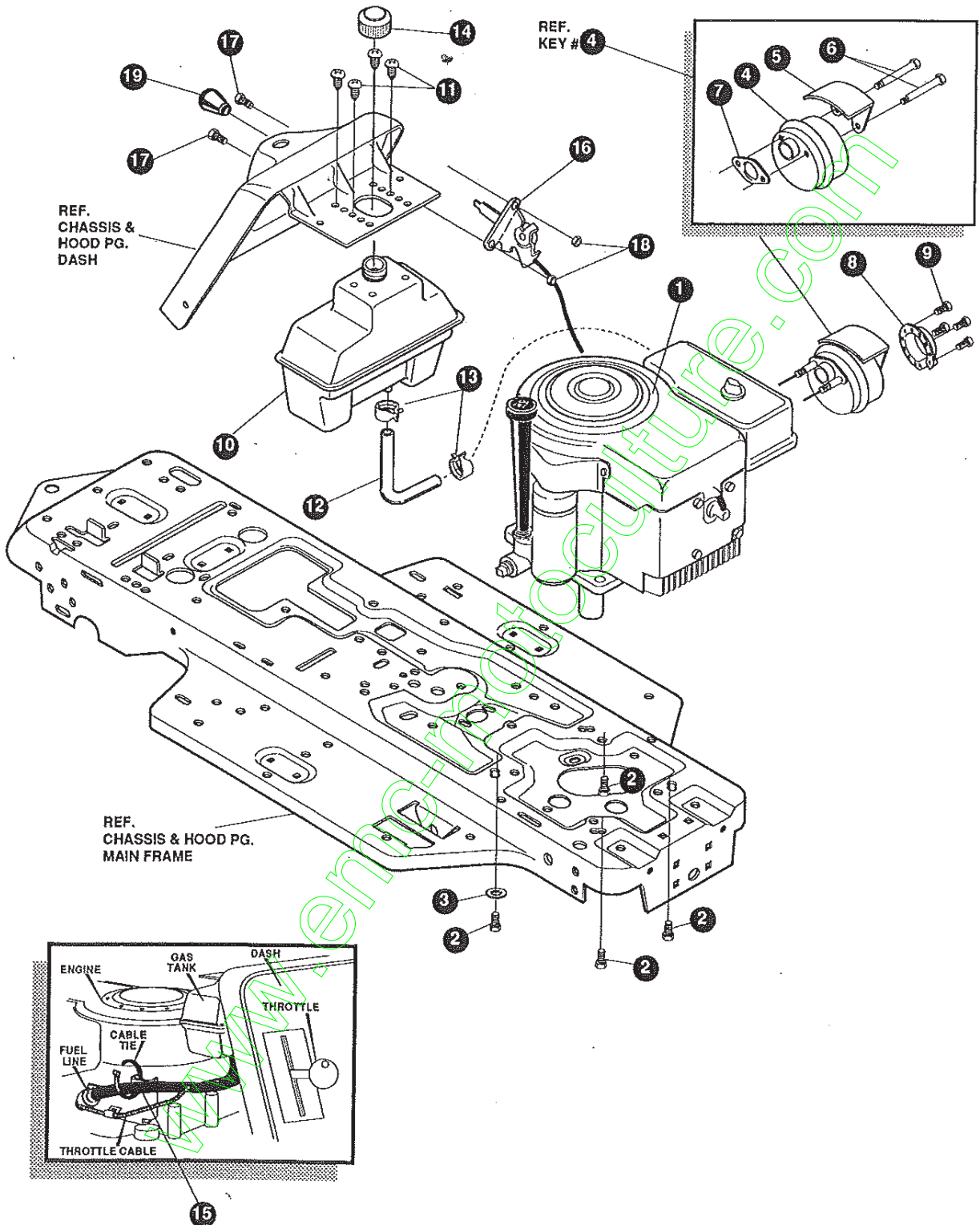

NOTE: ALWAYS USE ORIGINAL EQUIPMENT PARTS. Use of service/replacement parts other than original equipment parts may void your warranty.

ALL UNNUMBERED ITEMS ARE INTERCHANGEABLE WITH OPPOSITE SIDE

325648A

40" LAWN TRACTOR MODEL D3554-020

KEY#	PART#	DESCRIPTION	QTY.
1	ENGINE	12.5 B&S I/C DUAL CIR (SEE ENGINE MANUAL)	1
2	50947	SCREW, 3/8-16X1.25 WAHHTAP	4
3	138489	WASHER, EXLK .384X.69X.04	1
4	57908	MUFFLER NELSON LO-TONE	1
5	54767	SHIELD, HEAT FOR ROUND MUFFLER	1
6	173063	SCREW, 5/16-18X3.50 HHC	2
7	46708	GASKET MUFFLER	1
8	323423	DEFLECTOR SIDE OUT	1
9	35287	SCREW, 8-32X.38 HHWATAP	3
10	314989	TANK, FUEL 1 GALLON	1
11	49050	SCREW, 1/4-10X .75PHPNTAP	4
12	42258	GAS LINE .25ID BULK LENGTH	12"
13	47345	CLAMP, GAS LINE (1/2 DIA HOSE)	2
14	46704	GAS CAP	1
15	57444	TIE, CABLE	1
16	320031	THROTTLE CONTROL	1
17	35291	SCREW, 10-24X .50 SLHHMA	2
18	271166	NUT, #10-24 HEXKEPS	2
19	50607	KNOB, ROUND THROTTLE	1

www.emc-motoculture.com

40" LAWN TRACTOR MODEL D3554-020

PRE-PAINTED DECK

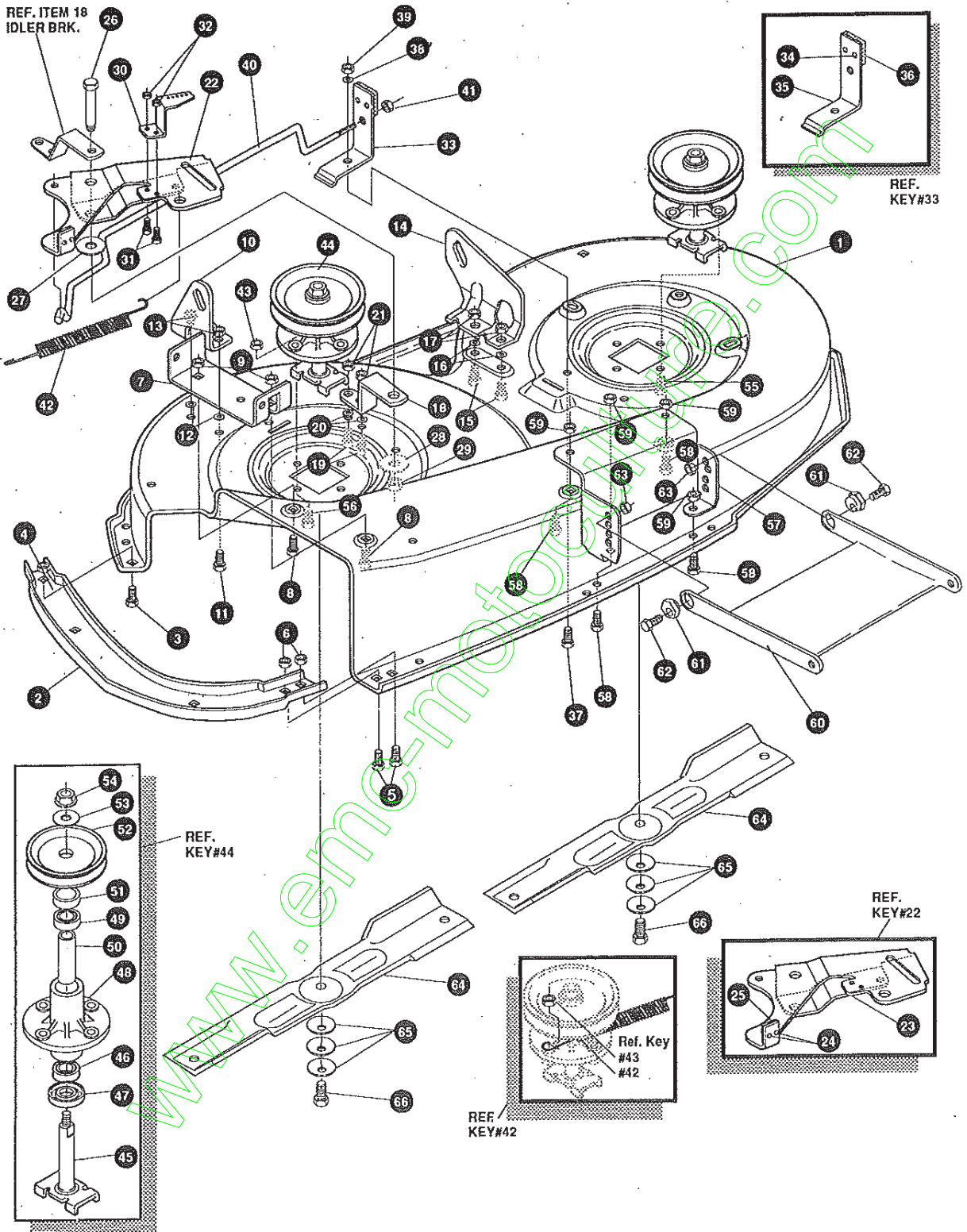

NOTE: ALWAYS USE ORIGINAL EQUIPMENT PARTS. Use of service/replacement parts other than original equipment parts may void your warranty.

ALL UNNUMBERED ITEMS ARE INTERCHANGEABLE WITH OPPOSITE SIDE

325650C

40" LAWN TRACTOR MODEL D3554-020

KEY#	PART#	DESCRIPTION	QTY.
1.	325103-853	MOWER DECKS, RIDER 40"	1
2.	326480-853	TOE GUARD-MULCHER	1
3.	180075	SCREW, 5/16-18X .63 HHC	1
4.	1498	NUT, 5/16-18 REGHEXCTRLK	1
5.	122007	SCREW, 5/16-18X .75 HHC	2
6.	1498	NUT, 5/16-18 REGHEXCTRLK	2
7.	317017	BRACKET CHUTE MOUNT	1
8.	180075	SCREW, 5/16-18X .63 HHC	2
9.	1498	NUT, 5/16-18 REGHEXCTRLK	2
10.	325652-853	BRACKET,RH LIFT REAR	1
11.	180077	SCREW, 5/16-18X .75 HHC	2
12.	120393	WASHER, FLAT .344X .69X.065	2
13.	1498	NUT, 5/16-18 REGHEXCTRLK	2
14.	325653-853	BRACKET,LH LIFT REAR	1
15.	180077	SCREW, 5/16-18X .75 HHC	2
16.	120393	WASHER, FLAT .344X .69X.065	2
17.	1498	NUT, 5/16-18 REGHEXCTRLK	2
18.	312273	BRACE IDLER	1
19.	180077	SCREW, 5/16-18X .75 HHC	2
20.	120393	WASHER, FLAT .344X .69X.065	2
21.	44108	NUT, 5/16-18 HWDFLCTRLK	2
22.	320576-853	IDLER ARM ASSEMBLY	1
23.	322116-853	ARM IDLER 40"DECK EURO	1
24.	41601	RIVET, OVSET .187DIA X .50	2
25.	306973	BRAKE PAD - HARD	1
26.	304420	BOLT, .500X2.15 HXHDCPSH	1
27.	996307	WASHER, FLAT .391X1.00X.209	1
28.	996416	WASHER, FLAT .391X1.00X.125	2
29.	45171	NUT, 3/8-16 HWDFL WHIZ-LOCK	1
30.	326249-853	BRACKET, EXTENSION IDLER	1
31.	180075	SCREW, 5/16-18X .63 HHC	2
32.	1498	NUT, 5/16-18 REGHEXCTRLK	2
33.	321828	BLADE BRAKE ASSY.	1
34.	135624	RIVET, TRSET .185DIA X .41LG	2
35.	304119	BRAKE ARM	1
36.	306973	BRAKE PAD	1
37.	180075	SCREW, 5/16-18X .63 HHC	1
38.	120393	WASHER, FLAT .344X .69X.065	1
39.	1498	NUT, 5/16-18 REGHEXCTRLK	1
40.	302714	ROD, BRAKE	1
41.	1502	NUT, 1/4-20 REGHEXCTRLK	1
42.	35410	SPRING .071 X .62 X 4.37	1
43.	1498	NUT, 5/16-18 REGHEXCTRLK	1
44.	56424-853	QUILL ASSY, 36/39/40/43	2
45.	56425	SHAFT/SADDLE 36"	1
46.	49562	BRNG, BALL .669IDX1.575ODX.472	1
47.	50616	DUST SHIELD	1
48.	55547	QUILL CASTING (1046)	1
49.	49562	BRNG, BALL .669IDX1.575ODX.472	1
50.	50818	SPACER, SLEV .669X .88X3.797	1
51.	51449	SPACER, SLEV .672X .93X .438PM	1
52.	313898	PULLEY,26/36" QUILL	1
53.	56365	WASHER, SPECIAL QUILL	1
54.	1282	NUT, 7/16-20 WDFLLK	1
55.	50634	SCREW, 5/16-18X .88 WAHTAP	7
56.	300345	SCREW, 5/16-18X1.38 WATAP	1
57.	318445	BRACKET,40 LF FRONT DECK	1
58.	180075	SCREW, 5/16-18X .63 HHC	4
59.	1498	NUT, 5/16-18 REGHEXCTRLK	4
60.	58305-853	BRACKET, LINK DECK FRONT	1
61.	58247	ADJUSTING NUT	2
62.	122017	SCREW, 5/16-18X1.00 HHC	2
63.	1498	NUT, 5/16-18 REGHEXCTRLK	2
64.	313316	BLADE, 40" STD-LIFT 20.324	2
65.	2483	WASHER, .39IDX1.25DX.07 BELLVIL	6
66.	39573	SCREW, 3/8-24X1.00 NYLHHC	2

40" LAWN TRACTOR MODEL D3554-020

FINAL DECK ASSEMBLY

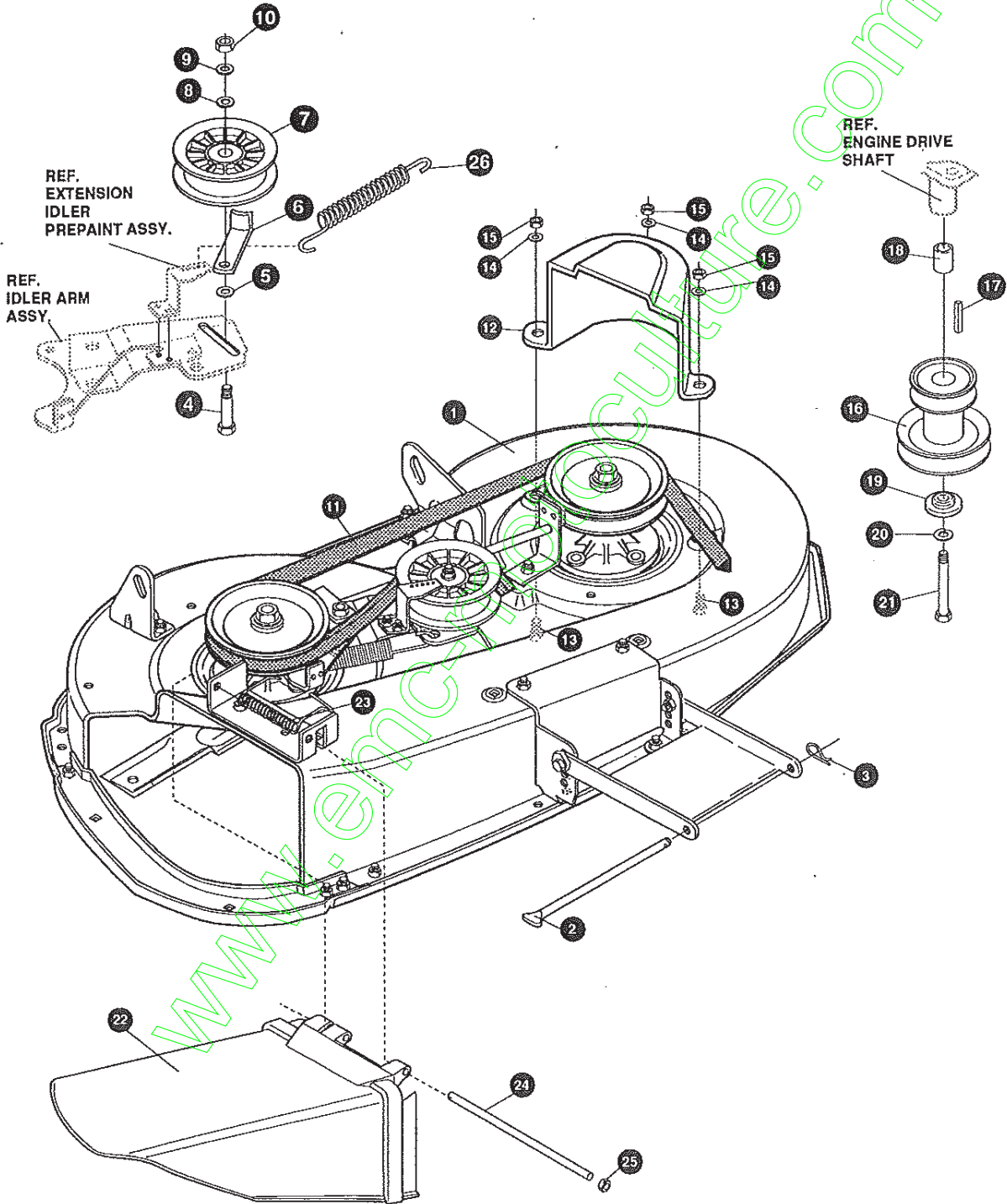

NOTE: ALWAYS USE ORIGINAL EQUIPMENT PARTS.
Use of service/replacement parts other than original equipment parts may void your warranty.

**ALL UNNUMBERED
ITEMS ARE INTERCHANGEABLE
WITH OPPOSITE SIDE**

325651B

40" LAWN TRACTOR MODEL D3554-020

KEY#	PART#	DESCRIPTION	QTY.
1.	^	DECK,40" MOWER 2-WH EXPORT	1
2.	58306	ROD, DECK HITCH	1
3.	8260	PIN, HAIR .091 DIA X 1.66 LG	1
4.	57325	BOLT, 3/8-16 X 2.00 CARR	1
5.	25210	WASHER, FLAT .392 X 1.25 X .09	1
6.	1345	RETAINER, BELT	1
7.	310326	PULLEY, IDLER BFF 4.00 WIDE FL	1
8.	996307	WASHER, FLAT .391 X 1.00 X .209	1
9.	120382	WASHER, REGSPTLK.393 X .68 X .10	1
10.	120377	NUT, 3/8-16 REGHX	1
11.	319005	BELT, V 5L 81.00 DECK 40 LF	1
12.	328257	GUARD, BELT LH PLASTIC	1
13.	180075	SCREW, 5/16-18 X .63 HHC	3
14.	120393	WASHER, FLAT .344 X .69 X .065	3
15.	1498	NUT, 5/16-18 REGHEX CTRLK	3
16.	310250	PULLEY, ENG. V3L 4.00 OFFSET	1
17.	303151	KEY SQUARE .249 SQ X 4.50 LG	1
18.	304246	SPACER SLEEVE 1.01 X 1.484 X	1
19.	56431	WASHER .98 OI DXL 1.38 X .437 PILOT	1
20.	120383	WASHER REGSPTLK .459 X .78 X .12	1
21.	433146	SCREW, 7/16-20 X 4.25 HHC	1
22.	304422	CHUTE DEFLECTOR 40°, 42° & 43°	1
23.	314975	SPRING TORISON CHUTE DEFLECTOR	1
24.	304424	ROD PIVOT DECK .312 X 7.25	1
25.	3535	NUT PUSH ON CAP	1
26.	325773	SPRING, TENSION .75 X 1.0 X .105	1

^ ORDER INDIVIDUAL PARTS.

40" LAWN TRACTOR MODEL D3554-020

ELECTRICAL ASSEMBLY

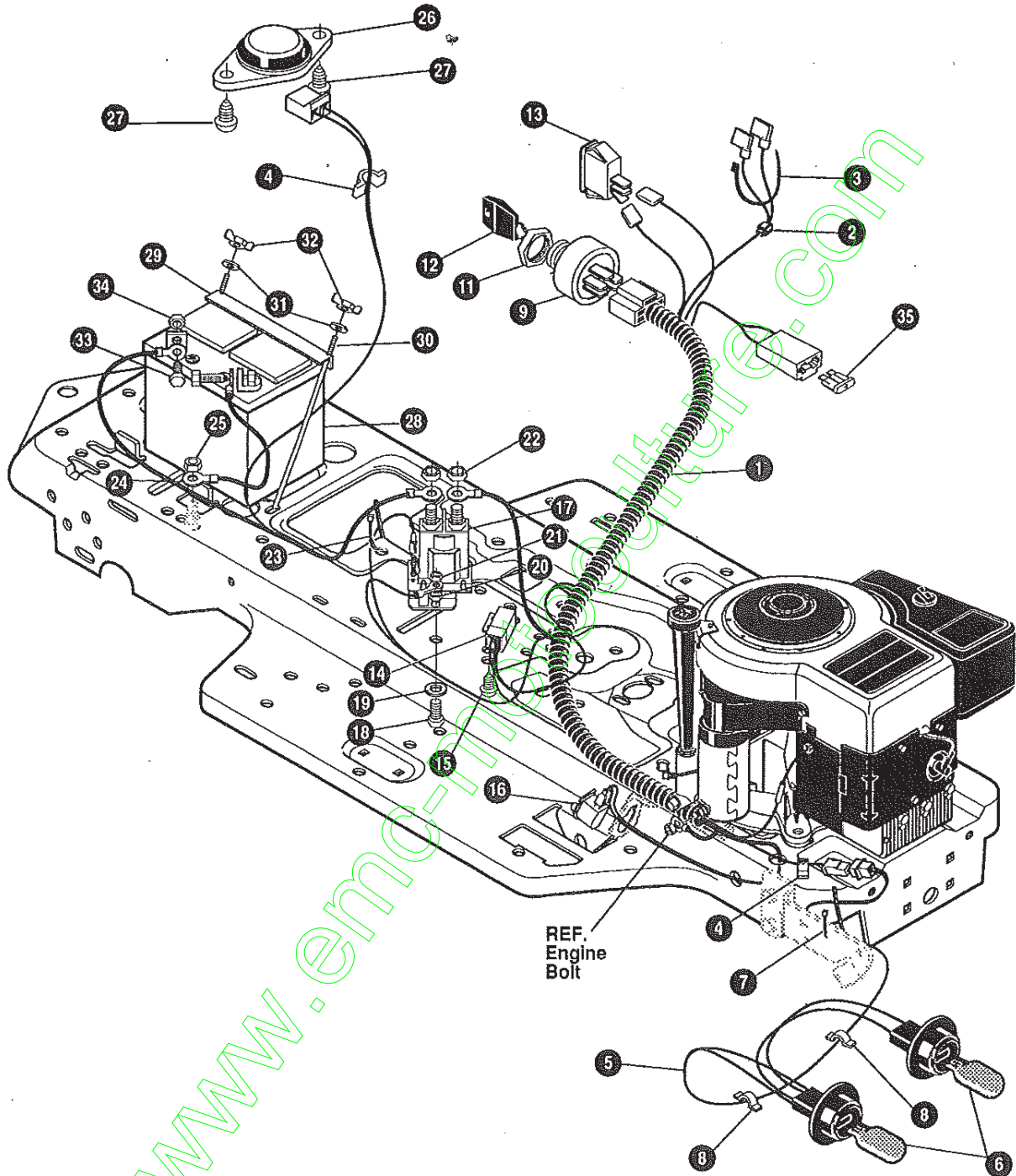

NOTE: ALWAYS USE ORIGINAL EQUIPMENT PARTS.
Use of service/replacement parts other than original equipment parts may void your warranty.

**ALL UNNUMBERED
ITEMS ARE INTERCHANGEABLE
WITH OPPOSITE SIDE**

326872A

40" LAWN TRACTOR MODEL D3554-020

KEY#	PART#	DESCRIPTION	QTY.
1.	325084	WIRE HARNESS SF 12B&S IC W/AMM	1
2.	322298	SPLICER	1
3.	57444	TIE,CABLE	1
4.	41482	PRESS CLIP,1.380LG .255ID	2
5.	303064	ASSY,LIGHT WIRE-1/4 TURN	1
6.	316823	BULB, HEADLAMP	2
7.	57444	TIE, CABLE BLACK NYLON 5.62L	1
8.	41482	PRESS CLIP,1.380LG .255ID	2
9.	327355	SWITCH-IGN.(AFTER FIRE) 3 POSN	1
11.	327352	NUT, 5/8-8 ACME DELTA	1
12.	327349	KEY, IGNITION SWITCH,STEEL	1
13.	300334	LIGHT SWITCH ON/OFF PANEL MNT	1
14.	57476	SWITCH,SCR MNT DP NC NO BLK	1
15.	57220	SCREW, #12 X .50 PHPNHTAP BLK	2
16.	326653	SWITCH,SNAPMNT NO .055/.116BLK	1
17.	53716	SOLENOID	1
18.	187745	SCREW, 1/4-20X .75 HXSEMMA	2
19.	1084	WASHER, FLAT .281X1.00X.063PL	1
20.	1502	NUT, 1/4-20 REGHEXCTRLK	2
21.	271172	NUT, 1/4-20 REGHEXKEPS	1
22.	271187	NUT, 5/16-24 HKEPS	2
23.	57444	TIE, CABLE BLACK NYLON 5.62L	1
24.	55511	WIRE, GROUND, 12.5"	1
25.	271184	NUT, 5/16-18 HEXKEPS	1
26.	57547	SWITCH, SEAT	1
27.	160505	SCREW, 1/4-20X .38PHPNHMA	2
28.	302257	BATTERY, YUASA 12V 6-PLATE	1
29.	324719	BATTERY BRACKET	1
30.	40234	BATTERY ROD	2
31.	120392	WASHER, FLAT .281X .63X.065	2
32.	325232	WINGNUT, 1/4-20 NYLON	2
33.	120854	SCREW, 1/4-20X .63 HHC	2
34.	271172	NUT, 1/4-20 REGHEXKEPS	2
35	** 302031	FUSE, 15 AMP SPADE TYPE	1

** Spade type fuse included with the wire harness.

SCHEMATIC DRAWING

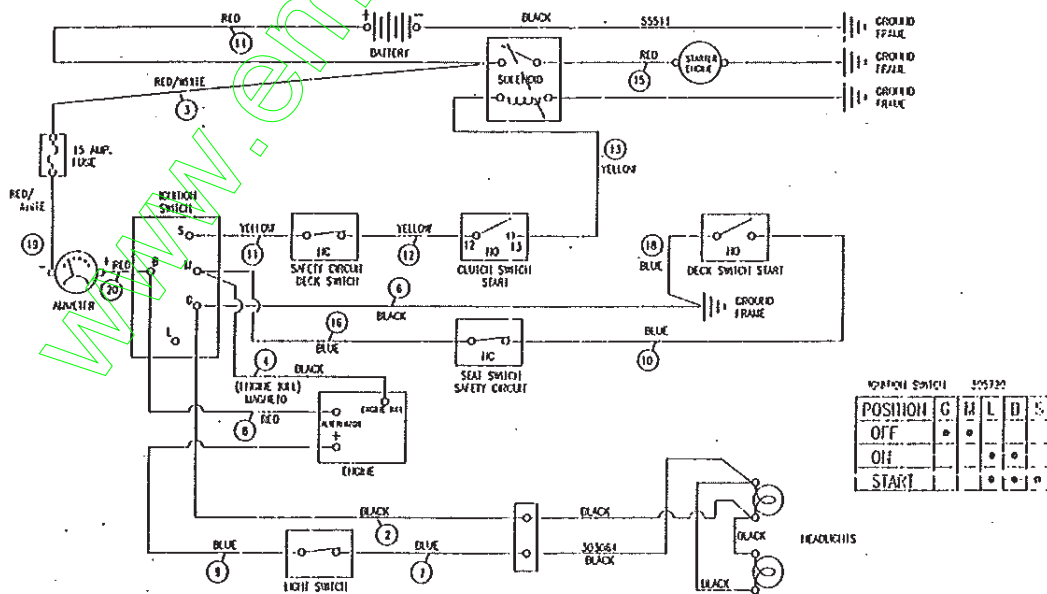

40" LAWN TRACTOR MODEL D3554-020

DECALS (DECORATIVE)

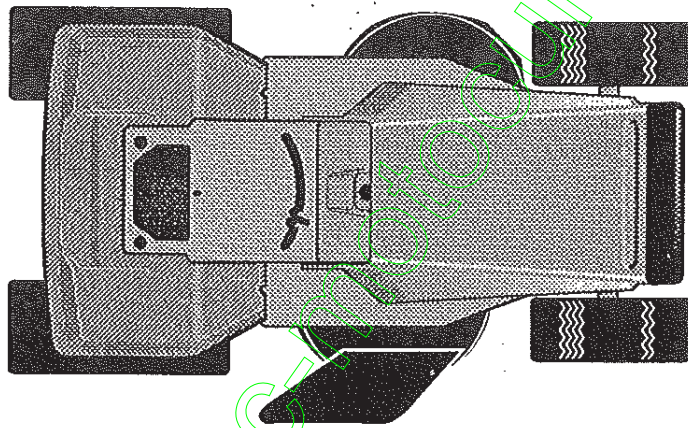
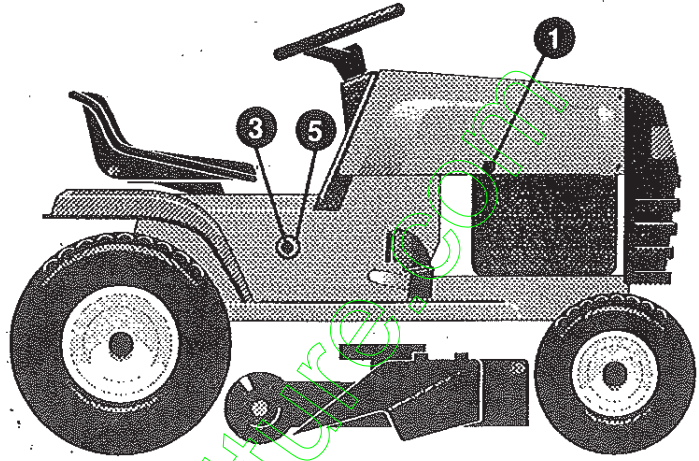
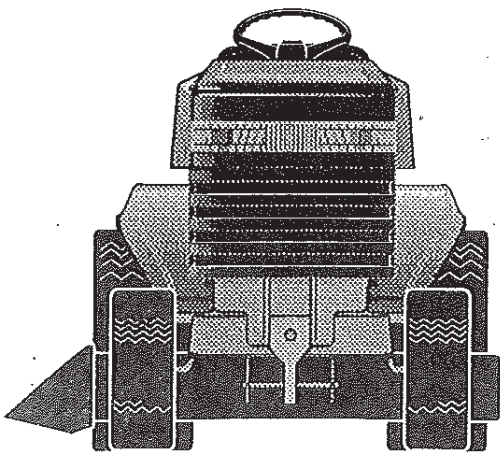

CONSOLE DETAIL

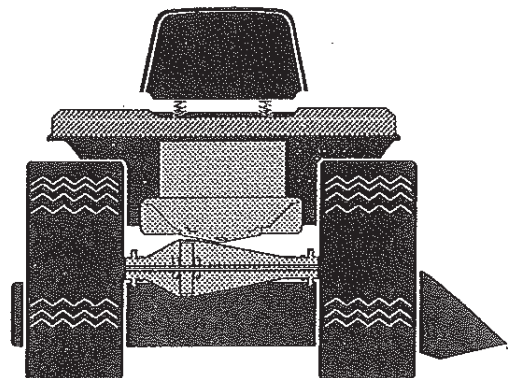
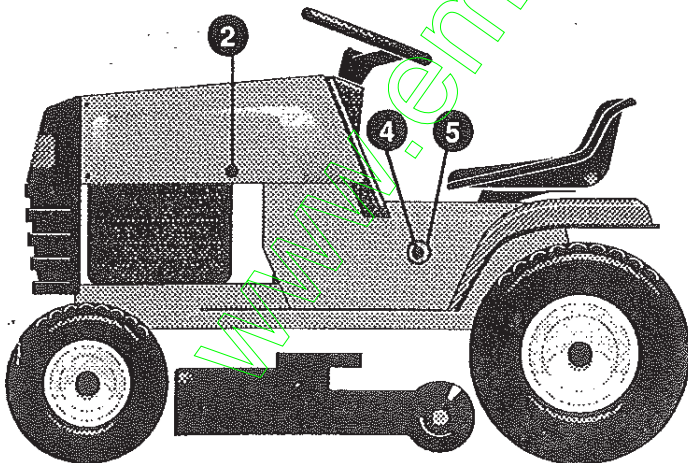
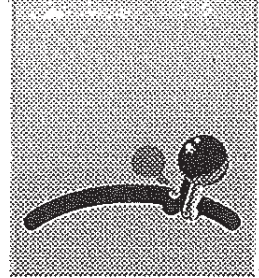

40" LAWN TRACTOR MODEL D3554-020

KEY#	PART#	DESCRIPTION	QTY.
1.	314456	DECAL, HOODSIDE RH H-21	1
2.	314457	DECAL, HOODSIDE LH H-21	1
3.	320872	DECAL, CONSOLE RH STRETCH FRM	1
4.	320873	DECAL, CONSOLE LH STRETCH FRM	1
5.	322801	NAMEPLATE 12/40	2

www.emc-motoculture.com

40" LAWN TRACTOR MODEL D3554-020

DECALS (INSTRUCTIONAL)

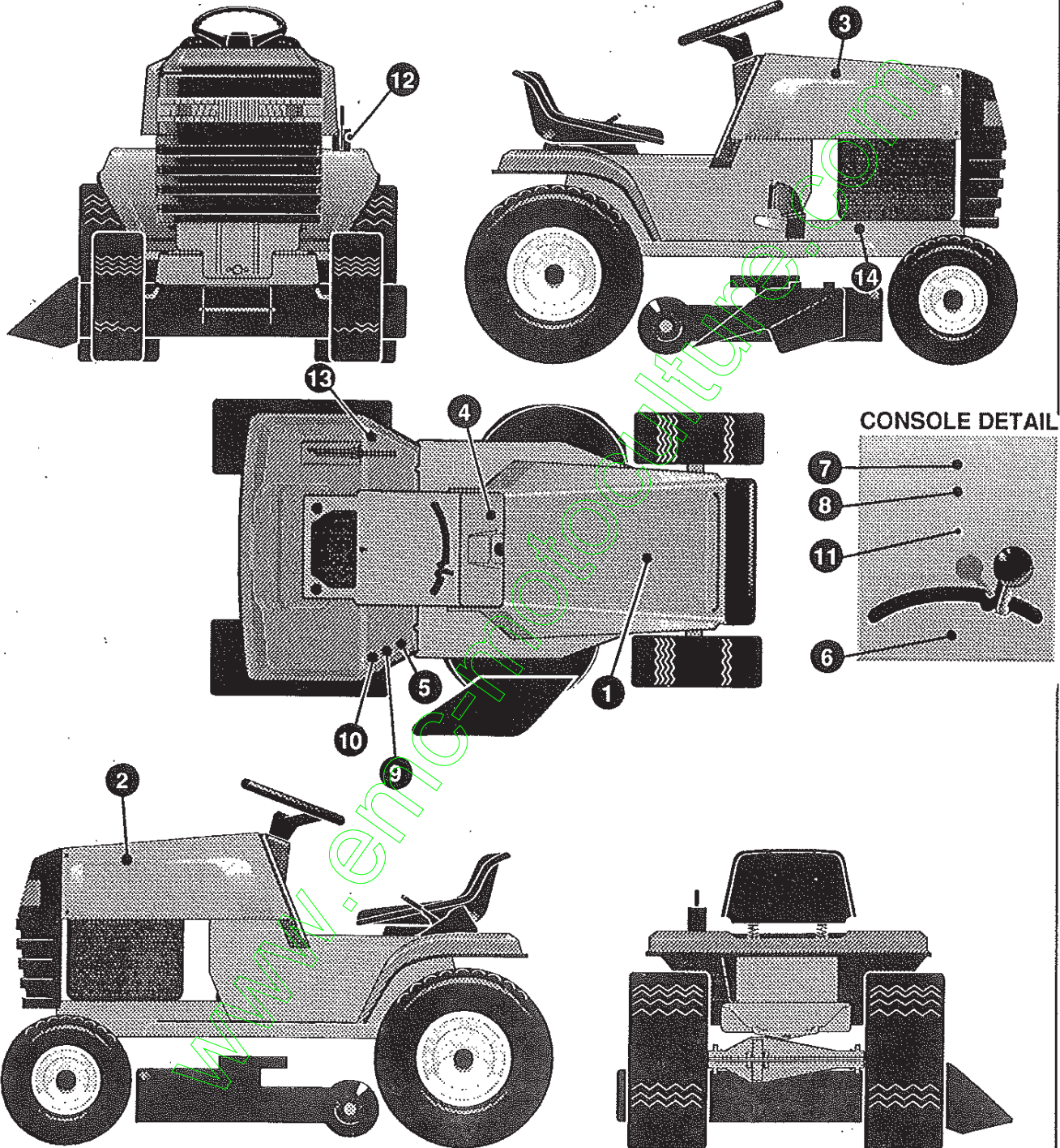

324787A

40" LAWN TRACTOR MODEL D3554-020

KEY#	PART#	DESCRIPTION	QTY.
1.	55832	PAD, FOAM TOP HOOD H-4	1
2.	55833	PAD, FOAM HOOD H-4 SIDE LH	1
3.	55834	PAD, FOAM HOOD H-4 SIDE RH	1
4.	324989	DECAL DASH, DYNAMARK	1
5.	305770	DECAL, CAUTION TRIANGLE EUROPE	1
6.	301104	DECAL, 5-SPEED CONSOLE TOP	1
7.	69524	DECAL, INSTRUCT CONSOLE TOP GER	1
8.	69525	DECAL, INSTRUCT CONSOLE TOP FR	1
9.	310553	DECAL, DANGER ENGLISH	1
10.	68902	DECAL, WARNING, FRENCH/GERMAN	1
11.	307383	DECAL, INSTRUCT ENGLISH	1
12.	301897	DECAL, LIFT DECK BLADE HEIGHT	1
13.	68901	DECAL, BLADE HEIGHT ADJ. EUROPE	1
14.	68903	DECAL, BRAKE/CLUTCH EUROPE	1

www.emc-motoculture.com

40" LAWN TRACTOR MODEL D3554-020

CUSTOMER ASSEMBLY

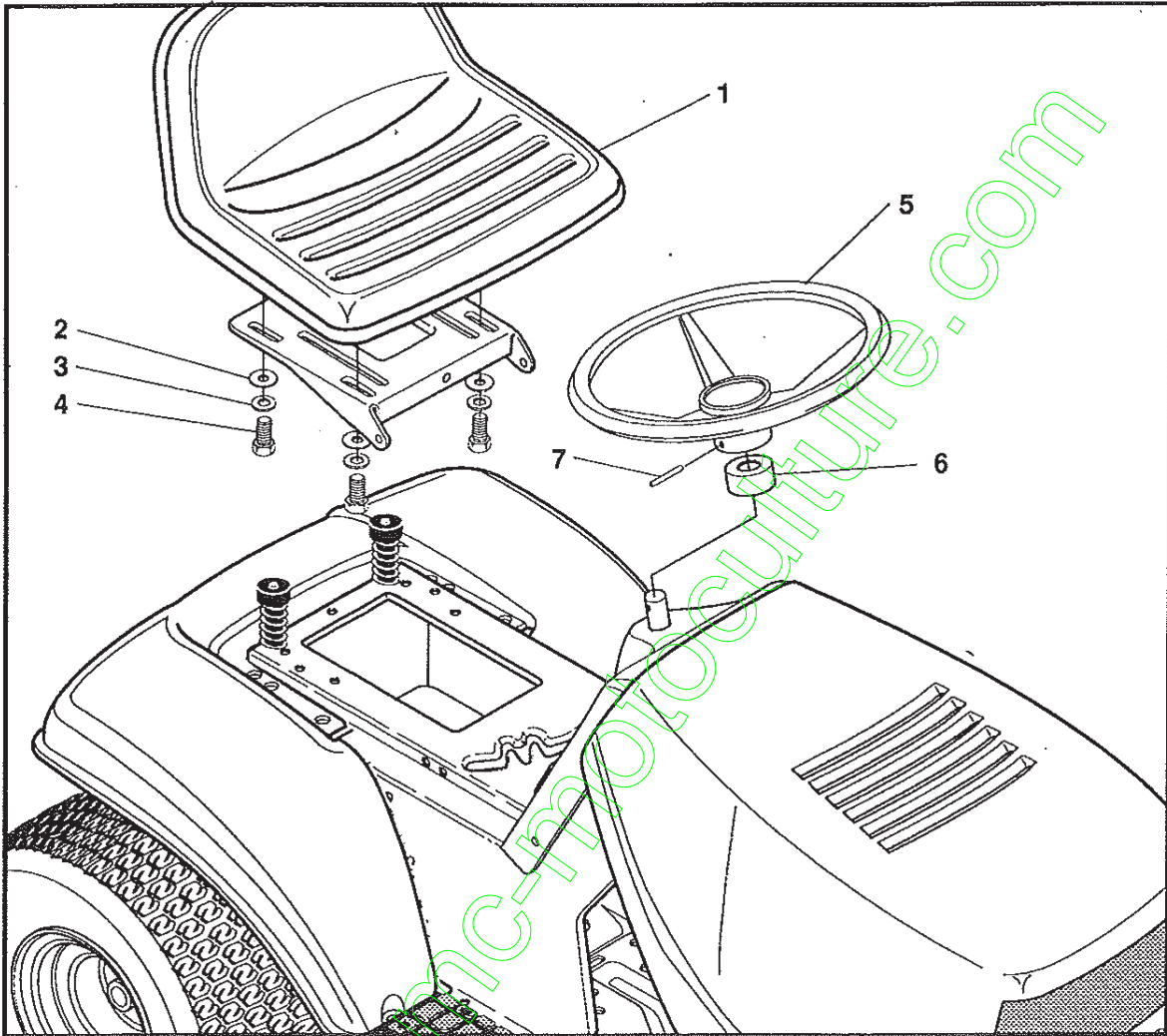

CUSTOMER ASSEMBLY VIEW

315134 PARTS BAG ASSY QTY1

KEY#	PART#	DESCRIPTION	QTY
1	304314	SEAT MV350	1
2	120398	WASHER, FLAT .344X.69X.065	4
3	120638	WASHER, HV SPLTLK .328X.60X.109	4
4	122007	SCREW, 5/16-18X.75 HHC	4
5	301251	STEERING WHEEL	1
6	323758	STEERING, SLEEVE	1
7	456378	ROLL PIN .250DIA X 2.0LG	1

316235C

40" LAWN TRACTOR MODEL D3554-020

TREAD PATTERNS

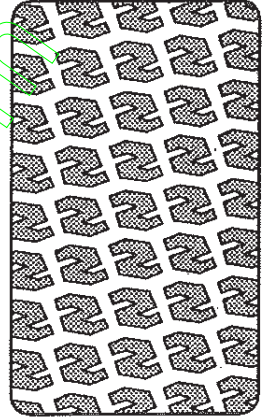
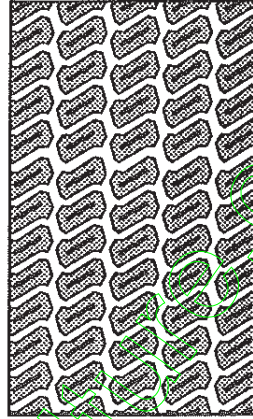
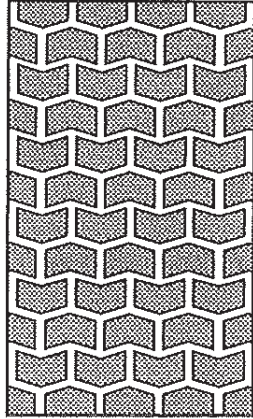
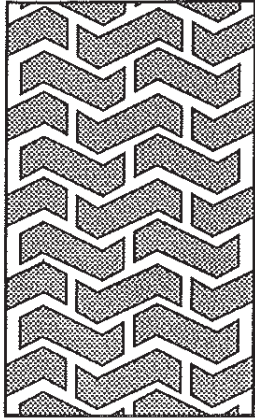

"A"

"B"

"C"

"D"

TIRE SIZE

"A"

"B"

"C"

"D"

11 X 4.00 - 5	42295	319679		
13 X 5.00 - 6	41060	319680		
15 X 6.00 - 6	39830	316702	301140	313952
16 X 6.50 - 8	41081	319682		314539
18 X 8.50 - 8	319683	317400		
18 X 9.50 - 8	41106	316701		313950
20 X 8.00 - 8	319685	319684	57164	314584
20 X 10.00 - 8	58276	319686		313654
20 X 10.00 - 10	55893	319687		
23 X 9.50 - 12	53655	319690	319689	314370

NOTES

www.emc-motoculture.com

NOTES

www.emc-motoculture.com

ACCESSORIES

Contact the dealer where your tractor was purchased for the available accessories. If you are unable to contact the dealer, write to the address on the front cover of this manual.

Rear Engine Rider	
Model	Description
5708-16	Bagger - Fits 32" Side Discharge
5708-17	Bagger - Fits 36" Side Discharge & 30" Top Discharge
5709-02	Front Weight Box - holds 35 lbs.
5648-16	Lawn Sweeper w/dump Release
5714-00	Mulching Kit - 30" Top Discharge

Lawn Tractor	
Model	Description
5708-22	Bagger - Fits 30" Side Discharge
5708-13	Bagger - Fits 36", 38", 39" & 45" Side Discharge
5705-04	36" Two-Stage Snowblower - Fits 36", 38", 39", & 45" Side Discharge
5661-06	42" Snowblade - Fits 36", 38", 39", & 45"
5592-00	Tire Chains - 18" x 6.50"
5585-00	Tire Chains - 18" x 9.50" & 20" x 8"
5672-01	Wheel Weights - Front - 1 pr. w/mtg. hdw. - Fits 15" tires
5673-02	Wheel Weights - Rear - 1 pr. w/mtg. hdw. - Fits 18" & 20" tires
5709-03	Front Weights - Fits 30" & 32" Side Discharge
5648-16	Lawn Sweeper w/dump Release
5714-00	Mulching Kit - 30" Top Discharge

Garden Tractor - Light Ground Engaging	
Model	Description
5708-13	Bagger - Fits 36", 38", 39", & 45" Side Discharge
5705-04	36" Two - Stage Snowblower - Fits 36", 38", 39", & 45"
5661-06	42" Snowblade - Fits 36", 38", 39", & 45"
5672-01	Wheel Weights - Front 1 pr. w/mtg. hdw. - Fits 15" tires
5673-02	Wheel Weights - Rear - 1 pr. w/mtg. hdw. - Fits 18" & 20" tires
5648-16	Lawn Sweeper w/dump Release
5667-02	Sleeve Hitch - w/lift bar - Fits 45"
5668-01	Adaptor (sleeve hitch) for use w/23" tires
5706-00	Tire Chains - 20" x 10"
5671-00	Tire Chains - 23" x 9.50"
5672-02	Wheel Weights - Front - 1 pr. w/mtg. hdw. Fits 16" tires
5673-00	Wheel Weights - Rear - 1 pr. w/mtg. hdw. Fits 23" tires
5674-01*	10" One Bottom Moldboard Plow
5675-01*	Cultivator - 7 row - Adj. 6" - 42" width
5676-01*	Disc Harrow - 8" & 11" disc - Adj. width & disc angle
5677-02*	Tiller - 5 H.P. Self-Powered - 28" width

Four Wheel Steer	
Model	Description
5708-14	Bagger - Fits 40" & 46" Side Discharge
5705-05	42" One-Stage Snowblower - Fits 40" & 46"
5661-07	48" Snowblade - Fits 40" & 46"
5709-04	Rear Weight Box for 40" & 46"
5648-16	Lawn Sweeper w/dump Release
5706-00	Tire Chains 20" x 10"
5671-00	Tire Chains 23" x 9.50"
5672-02	Wheel Weights - Front - 1 pr. w/mtg. hdw. Fits 16" tires
5673-00	Wheel Weights - Rear - 1 pr. w/mtg. hdw. Fits 23" tires
5672-01	Wheel Weights - Front - 1 pr. w/mtg. hdw. Fits 15" tires
5673-02	Wheel Weights - Rear - 1 pr. w/mtg. hdw. Fits 18" & 20" tires

Two Wheel Steer Garden Tractor	
Model	Description
5667-04	Sleeve Hitch - w/lift bar Fits 46"
5674-01*	10" One Bottom Moldboard Plow
5675-01*	Cultivator - 7 row - Adj. 6" - 42" width
5676-01*	Disc Harrow 8" & 11" Disc. Adj. width & disc angle
5677-02*	Tiller 5 H.P. Self-Powered - 28" width
5648-16	Lawn Sweeper w/dump Release

*Requires a sleeve hitch