

1238 D 1993

# REPAIR PARTS MANUAL

## 38" - 12 H.P. LAWN TRACTOR

### MODEL D3554-030

#### ONE YEAR LIMITED WARRANTY

For one (1) year from date of purchase by the first consumer for residential use (thirty (30) days commercial use), NOMA Outdoor Products Incorporated warrants that it will replace free of charge, including labor, any original part of any NOMA Outdoor Products Incorporated product found to be defective by any authorized Service Dealer or the factory, except the battery which is warranted for ninety (90) days from date of purchase.

This warranty does not cover engine, transmission, transaxle or differential (these items are covered by their manufacturer's own warranty). This warranty does not cover parts that have failed due to normal wear or parts that have failed subject to misuse or abuse. Transportation of the unit or part to and from an authorized Service Dealer or factory is the responsibility of the owner.

A step by step explanation as to what procedure should be followed for this warranty is:

1. If a part becomes defective, contact the store where the unit was purchased for the name and address of the authorized Service Dealer nearest to you.
2. If you cannot locate an authorized Service Dealer, write Service Department of NOMA Outdoor Products Incorporated for the name and address of the authorized Service Dealer in your area or call the Service Department at 1-901-422-1690.
3. Return the defective product, along with proof of purchase to such authorized Service Dealer for replacement of any defective part where covered by this warranty.

There is no other express warranty. Implied warranties, including those of merchantability and fitness for a particular purpose are limited to one (1) year from date of purchase. Liability for incidental or consequential damages are excluded.

Some states do not allow limitations on how long an implied warranty lasts, so the above limitation may not apply to you. Some states do not allow the exclusion of incidental or consequential damages, so the above exclusion may not apply to you. This warranty gives you specific legal rights, and you may have other rights which vary from state to state.

**NOMA Outdoor Products Incorporated**

**Caller 8000**

**Jackson, TN 38308-8000**

#### UNIT PARTS AND SERVICE

Fill in and mail the registration card packed with the unit. For service other than covered in this manual, contact an authorized service dealer. A nationwide parts and service organization has been established to provide locally available parts and service. When ordering repair parts, always give the following information: 1. The Part Name; 2. The Part Number; 3. The Quantity desired; 4. The Full (eight digit) Model Number of the unit. The model number will be found on a plate attached to the unit.



**Look for this symbol. It means - ATTENTION! BECOME ALERT! A HAZARD TO OPERATOR, BYSTANDER, PROPERTY OR EQUIPMENT MAY EXIST.**

**NOMA Outdoor Products Incorporated**

**Caller 8000**

**Jackson, TN 38308-8000**

Part No. 328448A

45/92

# 38" LAWN TRACTOR MODEL D3554-030

## CHASSIS & HOOD ASSEMBLY

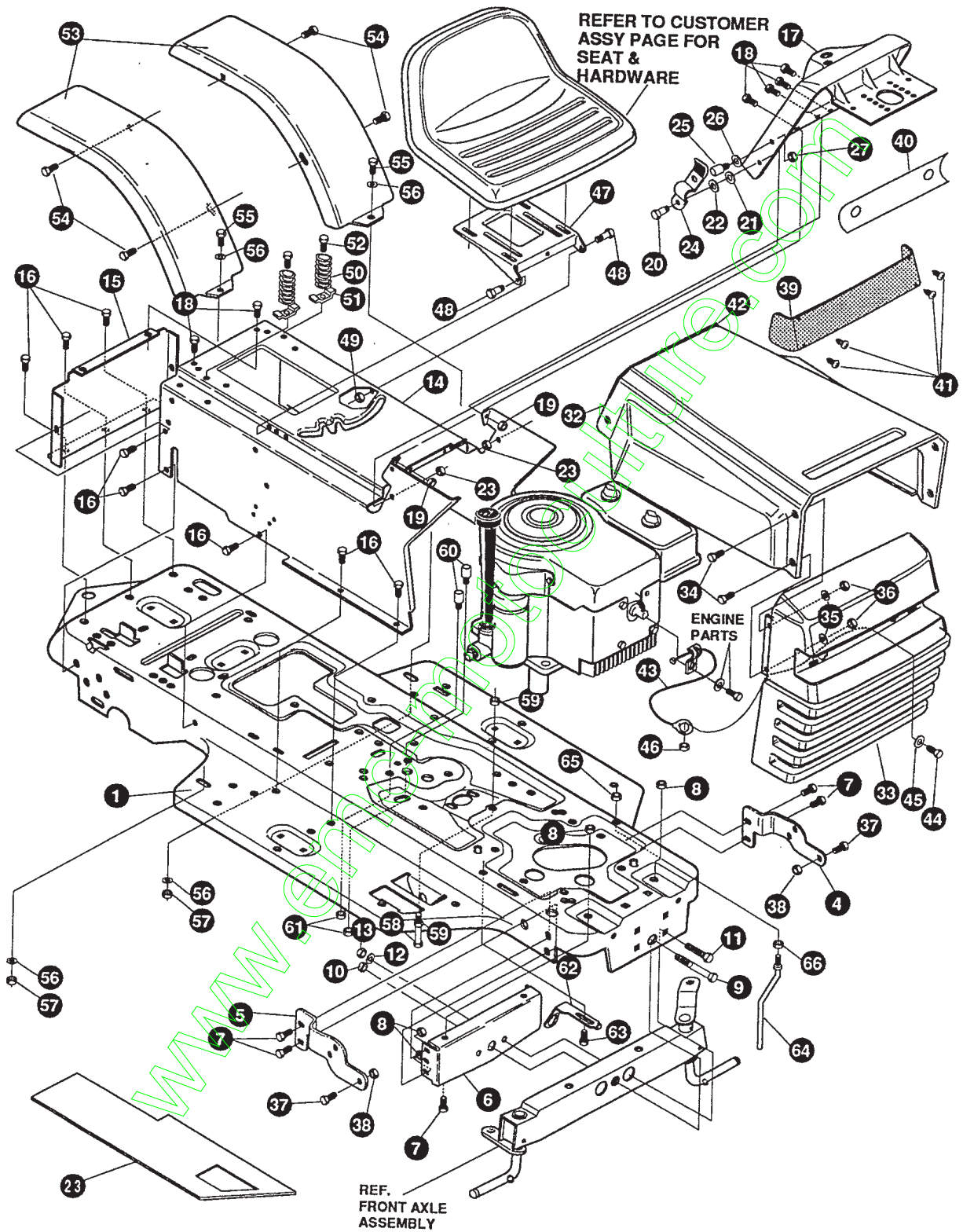

**NOTE:** ALWAYS USE ORIGINAL EQUIPMENT PARTS. Use of service/replacement parts other than original equipment parts may void your warranty.

**ALL UNNUMBERED ITEMS ARE INTERCHANGEABLE WITH OPPOSITE SIDE**

324796A

# 38" LAWN TRACTOR MODEL D3554-030

KEY#	PART#	DESCRIPTION	QTY.
1	321997-860	FRAME, MAIN SF RIDER	1
2	326732	FOOTPAD, LH SF WIDE	1
3	302916	FOOTPAD, RH SF WIDE	1
4	314579-853	BRACKET, GRILLE L.H.	1
5	314578-853	BRACKET, GRILLE R.H.	1
6	56362-853	BRACKET, SUPPORT FRT AXLE-	1
7	• 328154	SCREW, 5/16-18 X .75WDFLLK	6
8	• 55273	NUT, 5/16-18 HXWDFLLK	6
9	29616	BOLT, .625 X 2.875 SPSH 1/2-20	1
10	• 274654	NUT, 1/2-20 REGHXCTRLK	1
11	• 122201	SCREW, 3/8-16 X 2.75 HHC	2
12	2483	WASHER, .39 ID X 1.25 D X .07 BELLVIL	2
13	• 1499	NUT, 3/8-16 REGHXCTRLK	2
14	314491-860	CONSOLE, SF DYNA STYLE TOPSH	1
15	56235-860	CONSOLE, REAR COVER	1
16	• 995346	SCREW, 1/4-20 X .50 WAHHTAP	15
17	320466-860	DASH, SF NOMA DYNA STYLING	1
18	• 995338	SCREW, 1/4-20 X .63 HHWATAP	4
19	50352	NUT 1/4-20 WDFLLK TOP LOCK	2
20	8482	BOLT, .375 X .156 HSH 5/16-18	2
21	• 120394	WASHER, FLAT .406 X .81 X .065	2
22	• 120393	WASHER, FLAT .344 X .69 X .065	2
23	• 1498	NUT, 5/16-18 REGHEXCTRLK	2
24	57159	LATCH, .94 WD X .047 ASSEMBLY HOOD	2
25	53446	PIN, 5/16-18 HOOD LATCH	2
26	• 138538	WASHER, REGINTLK .320 X .61 X .03	2
27	• 45174	NUT, 5/16-18 HEXWDFLLK WHIZ	2
32	314538-860	HOOD	1
33	325401	GRILLE, DYNA-PRO	1
34	• 274672	SCREW, 1/4-20 X .63 WAHHC	4
35	• 120392	WASHER, FLAT .281 X .63 X .065	4
36	• 1502	NUT, 1/4-20 REGHEXCTRLK	4
37	36149	BOLT, .375 X .500 HSH 5/16-18	2
38	• 1498	NUT, 5/16-18 REGHEXCTRLK	2
39	302333	LENS, HEADLAMP	1
40	314948	FOIL, LENS DYNA-PRO REFLECTOR	1
41	• 57796	SCREW, #6 X .50 PLASTITE	4
42	52151	EDGING, WIDE BLK	25"
43	311094	LANYARD, HOOD	1
44	121887	SCREW, 1/4-20 X .75 HHC	1
45	120392	FLATWASHER .281 X .63 X .065	1
46	1502	LOCKNUT 1/4-20	1
47	58367-853	PLATE, SEAT F-5 SF & LF	1
48	20507	BOLT, .437 X .156 HSH 5/16-18	2
49	• 1498	NUT, 5/16-18 REGHEXCTRLK	2
50	56220	SPRING, 1.43 X 2.38 X .162 COM SEAT	2
51	1341	CLAMP, SPRING 1.17" ID	2
52	• 995346	SCREW, 1/4-20 X .50 WAHHTAP	2
53	43970-860	FENDER F-1	2
54	• 995346	SCREW, 1/4-20 X .50 WAHHTAP	4
55	• 122017	SCREW, 5/16-18 X 1.00 HHC	2
56	• 446363	WASHER, FLAT .375 X .88 X .082	4
57	• 1498	NUT, 5/16-18 REGHEXCTRLK	2
58	• 427342	SCREW, 3/8-16 X 6.50 HHC	1
59	• 1499	NUT, 5/16-18 REGHEXCTRLK	2
60	53446	PIN, 5/16-18	2
61	• 271184	NUT, 5/16-18 HEX KEPS	2
62	• 302610-853	BRACKET, SWITCH MOUNT	1
63	• 995346	SCREW, 1/4-20 X .50 WAHHTAP	1
64	50653	GUIDE, BELT	1
65	• 41529	NUT, 3/8-16 HXCTRLKJAM	1
66	• 271190	NUT, 3/8-16 HEXKEPS	1
	328448	PARTS MANUAL	1
	328656	OPERATORS MANUAL ENGLISH	1
	328832	OPERATOR'S MANUAL FRENCH	1
	328833	OPERATOR'S MANUAL GERMAN	1

• INDICATES STANDARD HARDWARE ITEMS.

# 38" LAWN TRACTOR MODEL D3554-030

## MOWER SUSPENSION

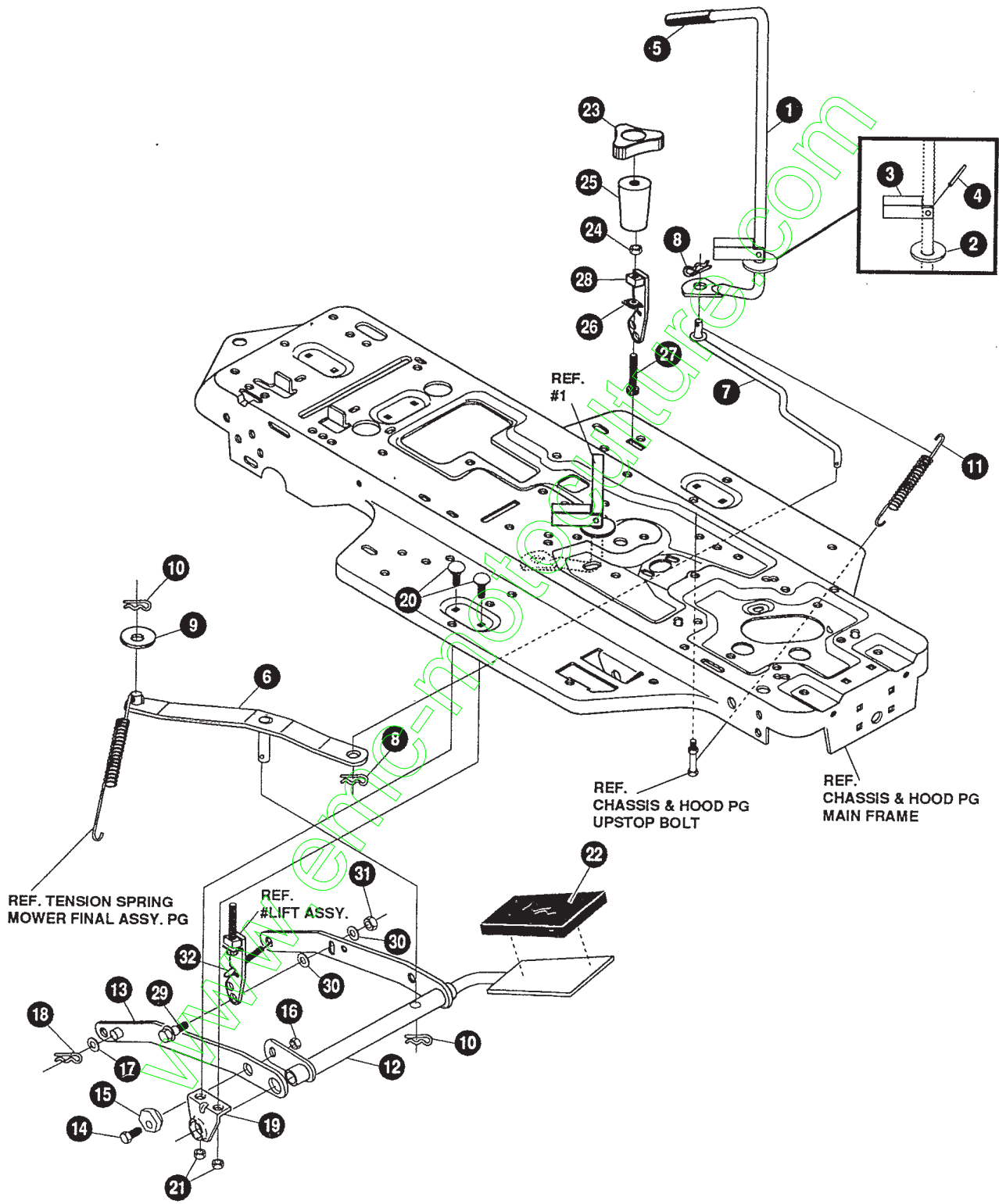

**NOTE:** ALWAYS USE ORIGINAL EQUIPMENT PARTS. Use of service/replacement parts other than original equipment parts may void your warranty.

ALL UNNUMBERED ITEMS ARE INTERCHANGEABLE WITH OPPOSITE SIDE

324978A

# 38" LAWN TRACTOR MODEL D3554-030

KEY#	PART#	DESCRIPTION	QTY.
1	325591	HANDLE, RH PTO DASH SF	1
2	22265	WASHER, FLAT .515 X 1.38 X .119 PL	1
3	305225	ML STOP, PTO ENGAGEMENT	1
4	326386	PIN, SPRING. 187 DIA X 1.13 LG HD	1
5	46478	GRIP, HAND .50 ID 3.37 LG BLK	1
6	325587-853	WS STRAP ASSEMBLY, PTO BELCRANK SF	1
7	325590	ROD, BELCRANK LINK	1
8	8260	PIN, HAIR .091 DIA X 1.66 LGZ	2
9	25210	WASHER, FLAT .392 X 1.25 X .09	1
10	8260	PIN, HAIR .091 DIA X 1.66 LGZ	2
11	325802	SPRING, .69 X 7.75 X .0897 TENSION	1
12	326533-853	WP LIFT ASSEMBLY, LH PEDAL-LIFT	1
13	325130-853	WP LIFT ASSEMBLY, RH SF	1
14	• 180079	SCREW, 5/16-18 X 1.00 HHC GR5 Z	1
15	• 58247	NUT, ADJUST	1
16	• 1498	NUT, 5/16-18 REGHEXCTRLK Z	1
17	417098	WASHER, FLAT .531 X 1.06 X .063 Z	2
18	8260	PIN, HAIR .091 DIA X 1.66 LG	2
19	325495-853	MP BRACKET, REAR HANG SUSP	1
20	126211	BOLT, 5/16-18 X .63 CARR GR2Z	4
21	• 1498	NUT, 5/16-18 REGHEXCTRLK	4
22	314488	PAD, LIFT PEDAL	1
23	325860	KNOB, FLUTED TORQUE BLACK	1
24	• 45905	NUT, 3/8-16 HWDFLCK MACK Z	1
25	326113	COVER, TOP SLEEVE PEDAL-LIFT	1
26	324983	WASHER, RUBBER 3/8 X .75 SQ	1
27	• 325832	BOLT, SUS MOWER LATCH SF	1
28	325831-853	WP LATCH, SUS MOWER SF	1
29	• 25086	BOLT, .500 X .375 HSSH 5/16-18 Z	1
30	4230	WASHER, FLAT .328 X .68 X .104	2
31	• 1498	NUT, 5/16-18 HWDFLCTRLK	1
32	35410	SPRING, .071 X .62 X 4.37	1

• INDICATES STANDARD HARDWARE ITEMS

# 38" LAWN TRACTOR MODEL D3554-030

## STEERING ASSEMBLY

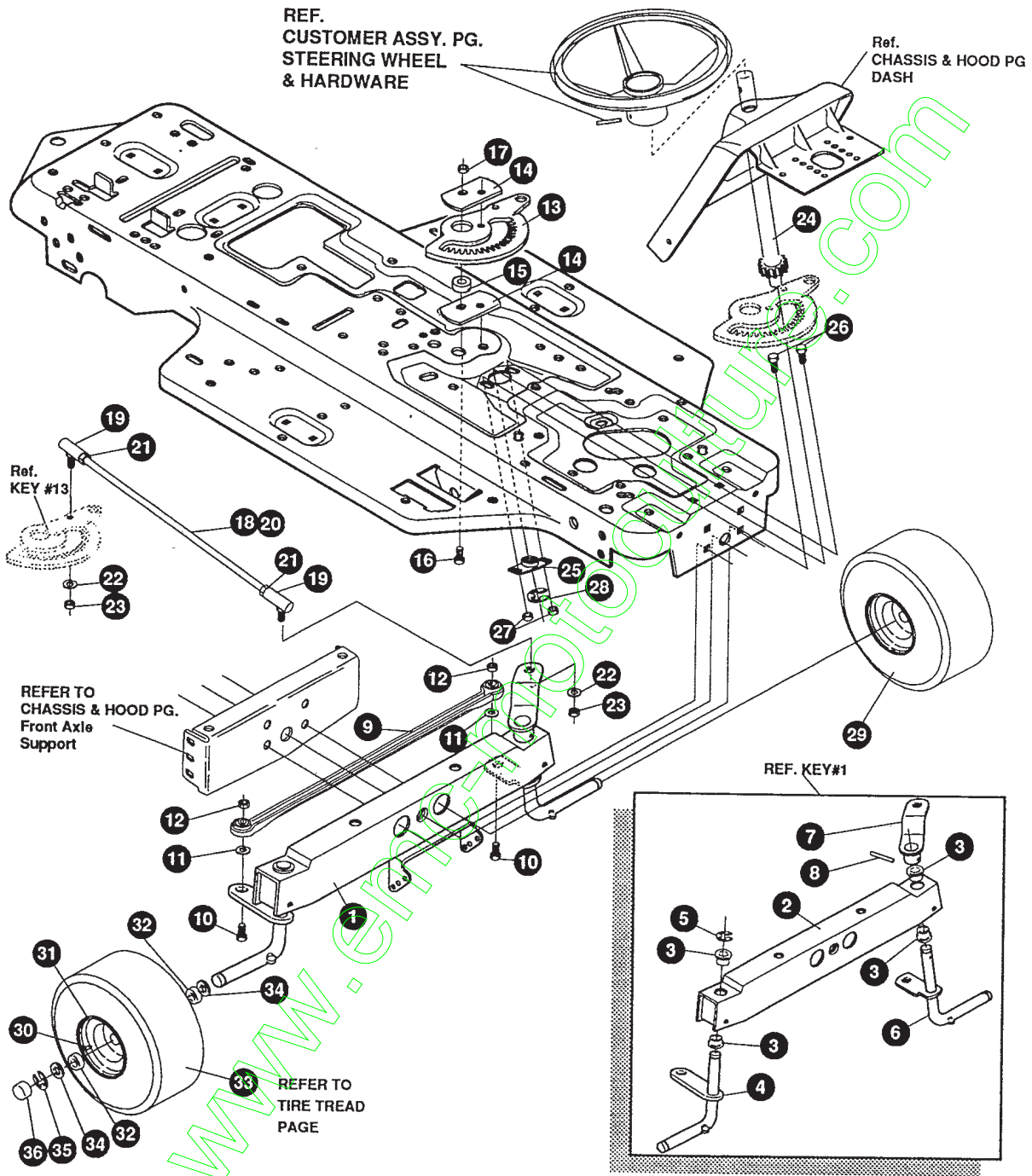

**NOTE:** ALWAYS USE ORIGINAL EQUIPMENT PARTS. Use of service/replacement parts other than original equipment parts may void your warranty.

**ALL UNNUMBERED ITEMS ARE INTERCHANGEABLE WITH OPPOSITE SIDE**

324972B

# 38" LAWN TRACTOR MODEL D3554-030

KEY#	PART#	DESCRIPTION	QTY.
1	^	FRONT AXLE ASSEMBLY SF	1
2	324915-860	AXLE, FRONT	1
3	50546	BEARING, FLANGE	4
4	310368	SPINDLE, RH	1
5	36625	RING, RETEX	1
6	310367	SPINDLE, LH	1
7	325223	ARM, STEERING LH	1
8	454565	PIN, SPRING	1
9	302688	TIE ROD	1
10	• 122145	SCREW, 3/8-16 X 1.25 HHC	2
11	• 120382	WASHER, .393 X .68 X .10 REGSPTLK	2
12	• 1499	NUT, 3/8-16 REGHCTRLK	2
13	324752	SECTOR, GEAR	1
14	327833	PLATE SECTOR SF 4WS	2
15	324753	BUSHING SECTOR GEAR SF 4WS	1
16	180124	SCREW, 3/8-16 X 1.25	1
17	1499	NUT, 3/8-16 REGHXCTRLK	1
18	• 56191	DRAGLINK ASSEMBLY	1
19	21275	BALL JOINT	2
20	56190	DRAGLINK	1
21	124925	NUT, 3/8-24 REGHEXJAM	2
22	120382	WASHER, REGSPTLK	2
23	120369	NUT, 3/8-24 REGHEX	2
24	327834	SHAFT PINION STEERING	1
25	325692	BEARING, FLANGE	1
26	326505	SCREW, 1/4-20 X .75 GRD 5	2
27	46931	NUT, 1/4-20 FLLK NUT SIDE LOCK	2
28	20864	RING RET E	1
29	302828	ASSEMBLY TIRE	2
30	24167	VALVE STEM	1
31	39829	WHEEL W/BEARING	1
32	314416	BEARING, 1.38 OD X .753ID FLANGE	2
33		REFER TO TIRE TREAD PAGE	
34	642	WASHER, FLAT .755 X 1.31 X .075	4
35	36625	RING, RETEX .57 X .05	2
36	40394	HUB CAP	2

- INDICATES STANDARD HARDWARE ITEMS.
- ^ ORDER INDIVIDUAL PARTS.





# 38" LAWN TRACTOR MODEL D3554-030

KEY#	PART#	DESCRIPTION	QTY.
1.	* Pee-less	TRANSAXLE P940-5SP SF FER	1
2.	302745	PULLEY, IDLER V4L 6.60	1
3.	3021	KEY, WDRF 606 .750 X .187 X .312	1
4.	22053	RING, RETEX .58 X .035 TRU 5100-62	1
5.	54758	BELT, V 4L 82.00 SF DRIVE	1
6.	53768-853	MP BRACKET, TRANSAXLE	2
7.	180075	SCREW, 5/16-18 X .63 HHC	6
8.	1498	NUT, 5/16-18 REGHEXCTRLK	6
9.	180089	SCREW, 5/16-18 X 2.25 HHC	4
10.	120393	WASHER, FLAT .344 X .69 X .065	4
11.	1498	NUT, 5/16-18 REGHEXCTRLK	4
12.	323213	MF BRACKET, T/A TORQ. 915 S/F	1
13.	180087	SCREW, 5/16-18 X 2.00 HHC	1
14.	1498	NUT, 5/16-18 REGHEXCTRLK	1
15.	122017	SCREW, 5/16-18 X 1.00 HHC	1
16.	138485	WASHER, EXLK .320 X .61 X .03	1
17.	1498	NUT, 5/16-18 REGHEXCTRLK	1
18.	12616	MH BRACKET, SHIFT P920-3SP	1
19.	56255	SCREW, 1/4-28 X .75 NYLHHC	1
20.	57157	WASHER, .750 X .250 SP-TRANSAXLE	1
21.	313934	LEVER, SHIFT 915 T/A S/F	1
22.	137185	PIN, COTTER .125 DIA X 1.00 LG	1
23.	55514-653	KNOB, ROUND 1.50 DIA BLACK	1
24.	49896	MF BELT GUIDE	1
25.	271184	NUT, 5/16-18 HEXKEPS	1
26.	120393	WASHER, FLAT .344 X .69 X .065	2
27.	1498	NUT, 5/16-18 REGHEXCTRLK	1
28.	302603-853	SF ASSEMBLY, BRAKE PEDAL S.F.	1
29.	319676	PIN, CLEVIS .5 DIA, 4.87 LG, ZN PL	1
30.	302601	SPACER, SLEV .53 X .62 X 1.406	1
31.	56180	PIN, HAIR .091 DIA X 1.62 LG	1
32.	48761	PAD, CLUTCH/BRAKE PEDAL	1
33.	321969	MF IDLER ARM BRACKET TRACTION SF	1
34.	41890	BOLT, .625 X .218 HSSH 5/16-18Z	1
35.	4107	WASHER, FLAT .635 X 1.31 X .07	1
36.	45602	WASHER, FLAT .333 X .87 X .119	1
37.	1498	NUT, 5/16-18 REGHEXCTRLK	1
38.	327867	SPRING, 3/4 OD X 6.75 X .091 TENSIO	1
39.	39659	MF RETAINER, BELT	1
40.	35374	PULLEY, IDLER V4L 3.06 X .62	1
41.	45892	BOLT, 3/8-16 X 1.50 CARR	1
42.	1499	NUT, 3/8-16 REGHXCTRLK	1
43.	43980	ROD, .268 DIA CLUTCH	1
44.	50562	SPRING, 3/8 OD X 1.625 X .055 TENSIO	1
45.	323210	BRACKET, TRACTION BRAKE S/F	1
46.	46824	BOLT, .500 X .188 HSSH 5/16-18Z	1
47.	1498	NUT, 5/16-18 REGHEXCTRLK	1
48.	323211	ROD, BRAKE 915 T/A SF	1
49.	313881	SPRING, CLUTCH .625 OD	1
50.	50352	NUT, 1/4-20 WDFLLK TOPLOCK	1
51.	^	TIRE & RIM, PU 20 X 8.0-8 TURWHI	2
52.	24167	VALVE STEM	1
53.	326362	WHEEL & HUB ASSY 20X8 WHITE	1
54.		REFER TO TIRE TREAD PAGE	
55.	52928	KEY, SQUARE .187 SQ X 2.25 LG	2
56.	642	WASHER, FLAT .755 X 1.31 X .075	4
57.	42815	WASHER, FLAT .755 X 1.53 X .07	2
58.	36625	RING, RETEX .57 X .05 TRU 5133-75	2
59.	40394	HUB CAP, 1.500ID X 7/8LG	2

• INDICATES STANDARD HARDWARE ITEMS.

^ ORDER INDIVIDUAL PARTS.

\* CONTACT YOUR NEAREST TRANSAXLE DEALER FOR PARTS AND SERVICE.

# 38" LAWN TRACTOR MODEL D3554-030

## ENGINE & CONTROL ASSEMBLY

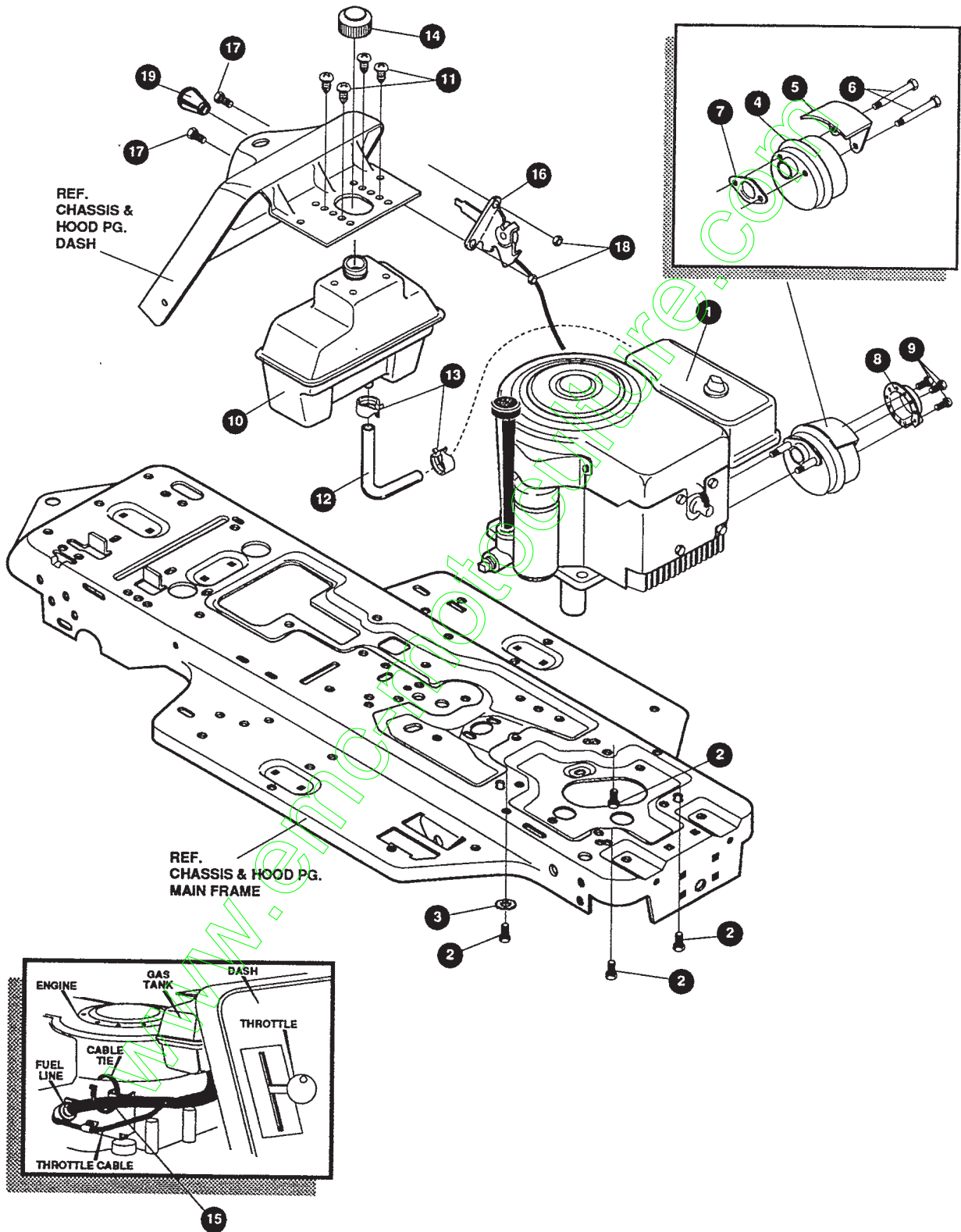

**NOTE:** ALWAYS USE ORIGINAL EQUIPMENT PARTS. Use of service/replacement parts other than original equipment parts may void your warranty.

**ALL UNNUMBERED ITEMS ARE INTERCHANGEABLE WITH OPPOSITE SIDE**

325601A

# 38" LAWN TRACTOR MODEL D3554-030

KEY#	PART#	DESCRIPTION	QTY.
1		ENGINE	1
2	• 50947	SCREW, 3/8-16 X 1.25 WAHHTAP	4
3	• 138489	WASHER, EXLK .384 X .69 X .04	1
4	57908	MUFFLER-LO TONE NELSON EXPORT	1
5	54767	SHIELD, HEAT, FOR ROUND MUFFLER	1
6	• 173063	SCREW, 5/16-18 X 3.50 HHC	2
7	46708	GASKET, MUFFLER	1
8	323423	DEFLECTOR, MUFFLER PARTIAL	1
9	35287	SCREW, #8-32 X .38 HHWATAP GR2	3
10	314989	TANK, FUEL 1 GAL	1
11	• 49050	SCREW, 1/4-10 X .75PHPNTAP	4
12	47452	GAS LINE, .25 ID	12"
13	47345	CLAMP, FUEL LINE	2
14	46704	GAS CAP 1-1/2-7 THD	1
15	57444	CABLE TIE	1
16	320031	THROTTLE CONTROL	1
17	• 35291	SCREW, 10-24 X .50 SLHMA	2
18	• 271166	NUT, #10-24 HEXKEPS	2
19	50607	KNOB, ROUND THROTTLE	1

• INDICATES STANDARD HARDWARE ITEMS.

www.emc-motoculture.com

# 38" LAWN TRACTOR MODEL D3554-030

## PRE-PAINTED DECK

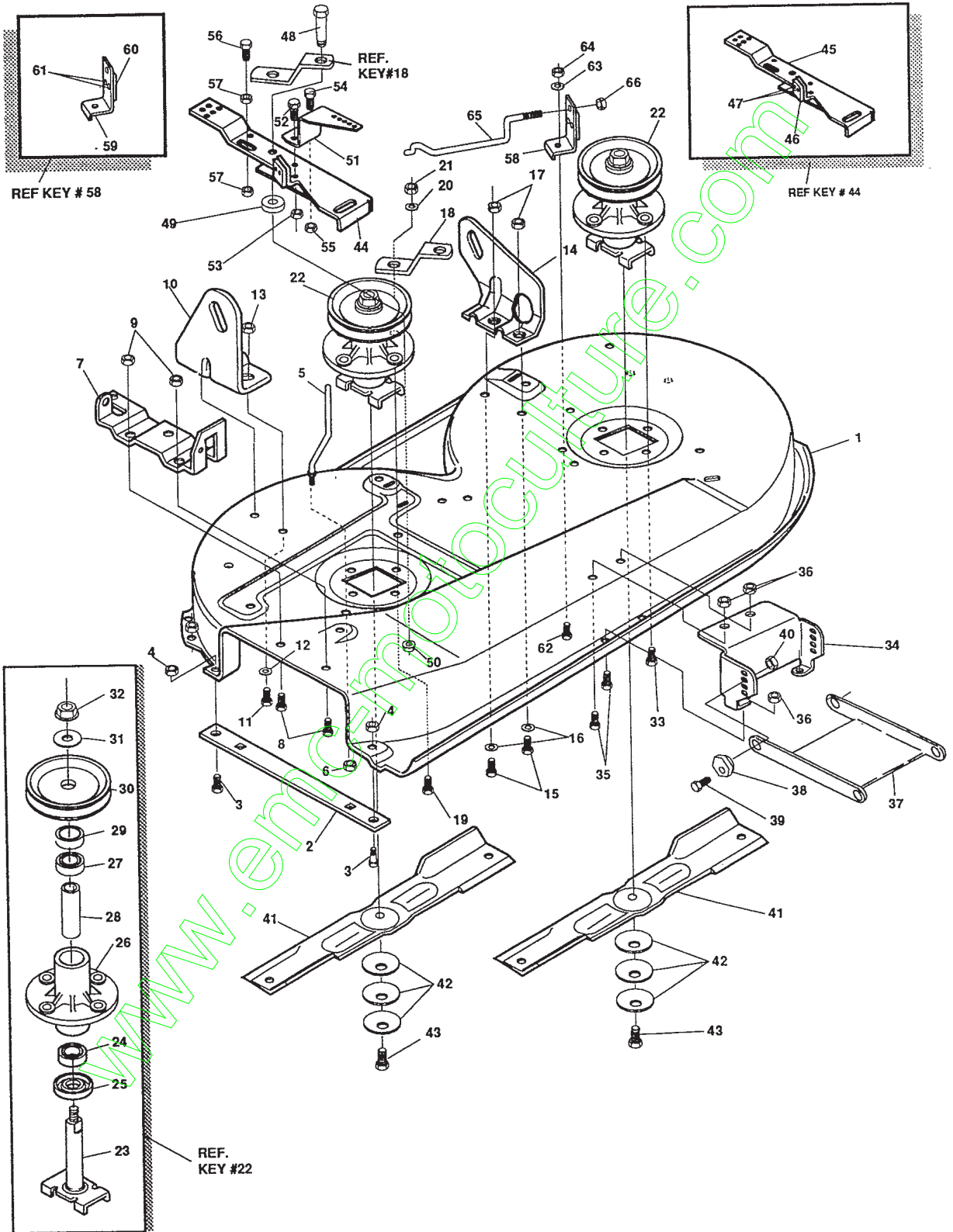

**NOTE:** ALWAYS USE ORIGINAL EQUIPMENT PARTS. Use of service/replacement parts other than original equipment parts may void your warranty.

**ALL UNNUMBERED ITEMS ARE INTERCHANGEABLE WITH OPPOSITE SIDE**

326046B

# 38" LAWN TRACTOR MODEL D3554-030

KEY#	PART#	DESCRIPTION	QTY.
1	325106-853	DECK, 38" SD MOWER	1
2	326295-853	BAR, SKID-MULCH	1
3	126216	BOLT, 5/16-18 X .75 CARR	2
4	• 1498	NUT, 5/16-18 REGHEXCTRLK	2
5	57318	GUIDE, BELT 5/16-18 THD	1
6	• 1498	NUT, 5/16-18 REGHEXCTRLK	1
7	313928	BRACKET, CHUTE	1
8	• 180073	SCREW, 5/16-18 X .50 HHC	2
9	• 1498	NUT, 5/16-18 REGHEXCTRLK	2
10	313929	LIFT BRACKET, REAR, RH	1
11	• 180077	SCREW, 5/16-18 X .75 HHC	2
12	120393	WASHER, FLAT .344 X .69 X .065	2
13	• 1498	NUT, 5/16-18 REGHEXCTRLK	2
14	310667	BRACKET, DECK LIFTREAR LH	1
15	• 180077	SCREW, 5/16-18 X .75 HHC	2
16	120393	WASHER, FLAT .344 X .69 X .065	2
17	• 1498	NUT, 5/16-18 REGHEXCTRLK	2
18	315302-853	BRACKET, IDLER SUPPORT	1
19	• 300345	SCREW, 5/16-18 X 1.38 WATAP	1
20	120393	WASHER, FLAT .344 X .69 X .065	1
21	• 1498	NUT, 5/16-18 REGHEXCTRLK	1
22	56424-853	QUILL ASSEMBLY, 36/39/40/43	2
23	56425	SHAFT/SADDLE 36"	1
24	49562	BEARING, BALL	1
25	50616	DUST SHIELD	1
26	55547	QUILL CASTING	1
27	49562	BEARING, BALL	1
28	50818	SPACER, 3.797 LG X .669 ID X .88OD	1
29	51449	SPACER, .438 LG X .932 OD X .672 ID-PM	1
30	313898	PULLEY, 26/36" QUILL	1
31	56365	SPECIAL WASHER	1
32	• 1282	NUT, 7/16-20 WDFLLK	1
33	• 50634	SCREW, 5/16-18 X .88 WAHTAP	8
34	312526	LIFT SUPPORT FRONT DECK	1
35	• 180075	SCREW, 5/16-18 X .63 HHC	4
36	• 1498	NUT, 5/16-18 REGHEXCTRLK	4
37	58305-853	LINK BRACKET, DECK FR	1
38	58247	ADJUSTING NUT	2
39	• 122017	SCREW, 5/16-18 X 1.00 HHC	2
40	• 1498	NUT, 5/16-18 REGHEXCTRLK	2
41	309069	BLADE, 19.69 LO-LIFT	2
42	2483	WASHER, .39 ID X 1.25 D X .07 BELLVIL	6
43	• 39573	SCREW, 3/8-24 X 1.00 NYLHHC	2
44	320565-853	IDLER ARM ASSEMBLY	1
45	300490-853	IDLER ARM	1
46	306973	BRAKE PAD	1
47	41601	RIVET,OVSET 187 DIA X .50 LG ST	2
48	300180	BOLT, .50 X .188 HSH3/8-16	1
49	996416	WASHER, FLAT .391 X 1.-- X .125	1
50	45171	NUT,5/16-18 X .75 HHC WHIZ-LOCK	1
51	326249-853	BRACKET EXTENSION IDLER	1
52	180077	SCREW, 5/16-18 X .75 HHC	1
53	1498	NUT, 5/16-18 REGHEXCTRLK	1
54	120854	SCREW, 1/4-20 X .63 HHC-GR2	1
55	1502	NUT, 1/4-20 REGHXCTRLK	1
56	121954	SCREW,1/4-20 X 2.00 HHC	1
57	271172	NUT, 1/4-20 REGHEXKEPS	2
58	303247-853	ASSEMBLY BLADE BRAKE	1
59	303246	BRAKE ARM	1
60	306973	BRAKE PAD	1
61	135624	RIVET,TRSET .185 DIA X .41	2
62	180075	SCREW, 5/16-18 X .63 HHC	1
63	120393	WASHER,FLAT .344 X .69 X .65	1
64	1498	NUT, 5/16-18 REGHEXCTRLK	1
65	300316	ROD, BRAKE	1
66	1502	NUT, 1/4-20 REGHEXCTRLK	1

• INDICATES STANDARD HARDWARE ITEMS

# 38" LAWN TRACTOR MODEL D3554-030

## FINAL DECK ASSEMBLY

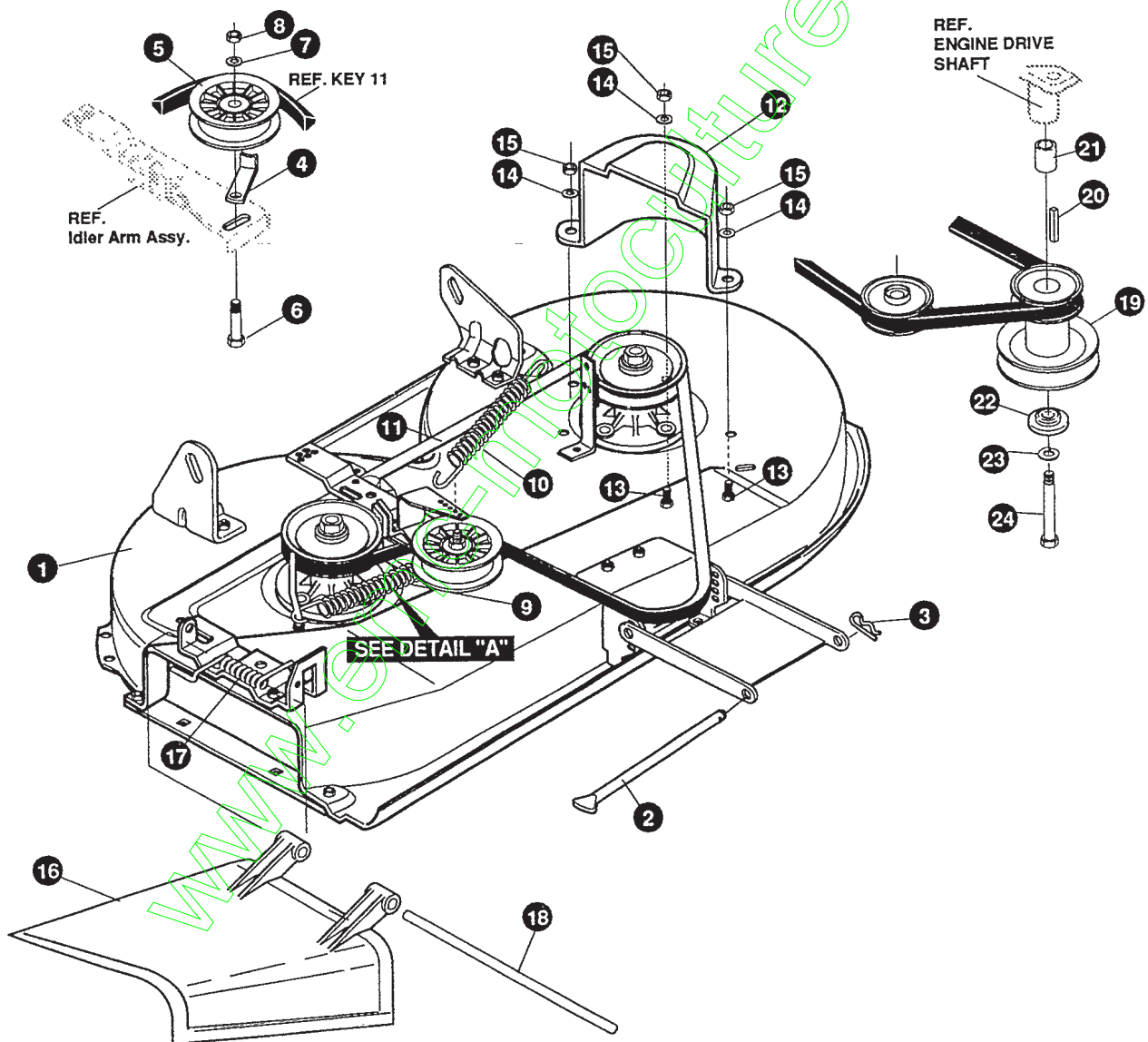

**NOTE:** ALWAYS USE ORIGINAL EQUIPMENT PARTS. Use of service/replacement parts other than original equipment parts may void your warranty.

**ALL UNNUMBERED ITEMS ARE INTERCHANGEABLE WITH OPPOSITE SIDE**

326048A

# 38" LAWN TRACTOR MODEL D3554-030

KEY#	PART#	DESCRIPTION	QTY.
1	^	ASSEMBLY DECK 39SD 2-DECKWH	1
2	58306	ROD, DECK HITCH	1
3	8260	PIN, HAIR .091 DIA X 1.66	1
4	1346	BELT RETAINER 2.55 OD	1
5	310326	PULLEY, IDLER BFF 4.00	1
6	57325	BOLT, 3/8-16 X 2.00 CARR	1
7	120382	WASHER, REGSPTLK .393 X .68 X .10	1
8	• 120377	NUT, 3/8-16 REGHX	1
9	322064	SPRING, .071 X .62 X 4.37	1
10	326256	SPRING, TENSION	1
11	300680	BELT, V 5L 77.75	1
12	302833	GUARD, BELT LH	1
13	180075	SCREW, 5/16-18 X .63 HHC	3
14	120393	WASHER, FLAT .344 X .69 X .065	3
15	• 1498	NUT, 5/16-18 REGHEXCTRLK	3
16	57818	CHUTE-36SD, 39SD	1
17	314975	SPRING, TORSION	1
18	57317	PIVOT ROD, CHUTE	1
19	310250	PULLEY ENGINE	1
20	303151	KEY SQUARE .249 X 4.50	1
21	304246	SPACER SLEEVE 1.01 X 1.48	1
22	56431	WASHER .980 X 1.38 X 4.37 PILOT	1
23	120383	WASHER, REGSPTLK .459 X .78 X .12	1
24	433146	SCREW, 7/16-20 X 4.25	1

• INDICATES STANDARD HARDWARE ITEMS

^ ORDER INDIVIDUAL PARTS.

# 38" LAWN TRACTOR MODEL D3554-030

## ELECTRICAL ASSEMBLY

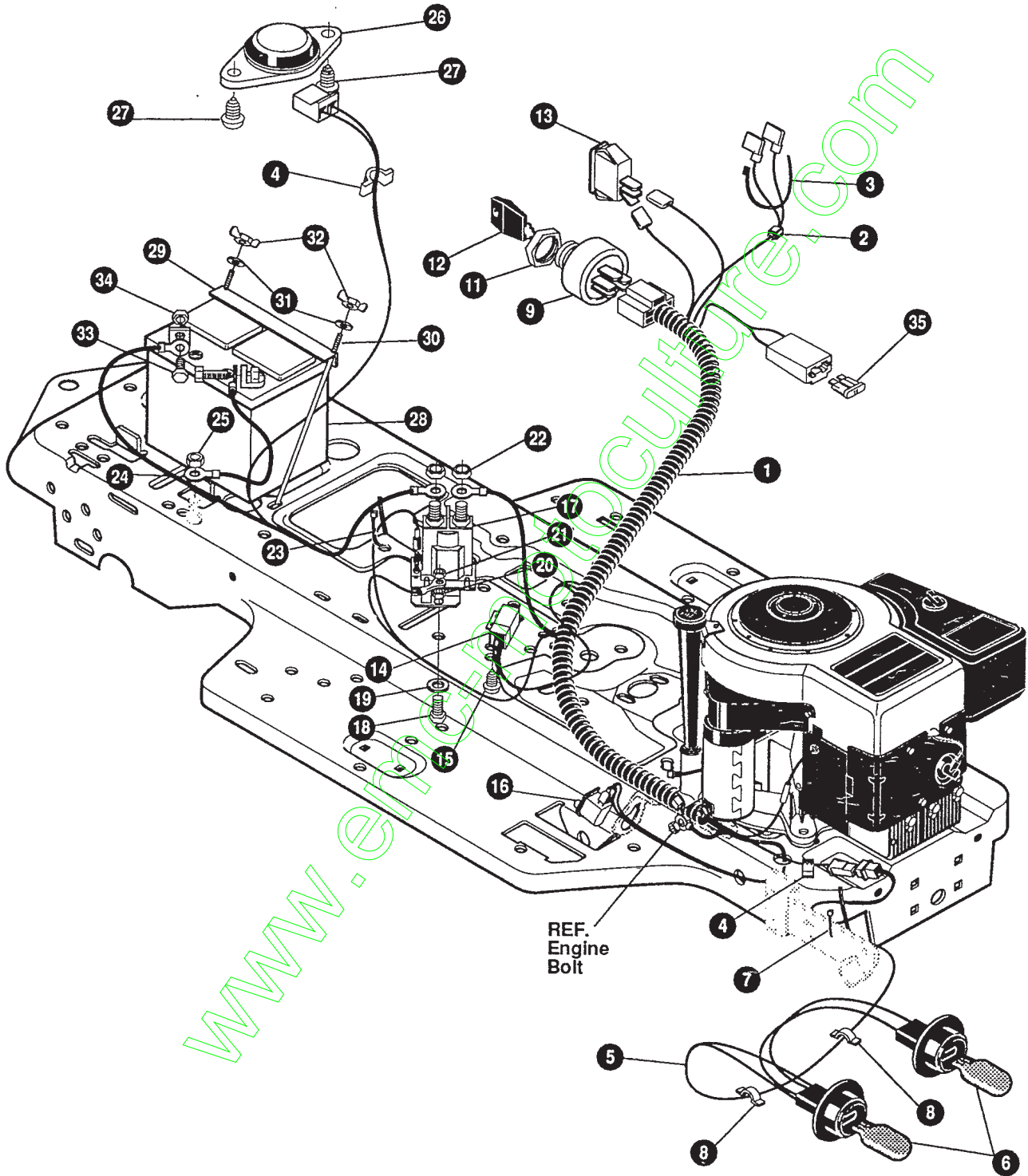

**NOTE:** ALWAYS USE ORIGINAL EQUIPMENT PARTS. Use of service/replacement parts other than original equipment parts may void your warranty.

ALL UNNUMBERED  
ITEMS ARE INTERCHANGEABLE  
WITH OPPOSITE SIDE

326872A



# 38" LAWN TRACTOR MODEL D3554-030

KEY#	PART#	DESCRIPTION	QTY.
1.	325084	WIRE HARNESS SF 12 B&S IC W/AMM	1
2.	322298	SPLICER	1
3.	57444	TIE, CABLE	1
4.	41482	PRESS CLIP, 1.380 LG .255 ID	2
5.	303064	ASSEMBLY, LIGHT WIRE-1/4 TURN	1
6.	316823	BULB, HEADLAMP	2
7.	57444	TIE, CABLE BLACK NYLON 5.62 L	1
8.	41482	PRESS CLIP, 1.380 LG .255 ID	2
9.	327355	SWITCH-IGN.(AFTER FIRE) 3 POSN	1
11.	327352	NUT, 5/8-8 ACME DELTA	1
12.	327349	KEY, IGNITION SWITCH, STEEL	1
13.	300334	LIGHT SWITCH ON/OFF PANEL MNT	1
14.	57476	SWITCH, SCREW MOUNT DP NC NO BLK	1
15.	• 57220	SCREW, #12 X .50 PHPNHTAP BLK	2
16.	326653	SWITCH, SNAPMNT NO .055/.116 BLK	1
17.	53716	SOLENOID	1
18.	• 187745	SCREW, 1/4-20 X .75 HXSEMMA	2
19.	1084	WASHER, FLAT .281 X 1.00 X .063 PL	1
20.	• 1502	NUT, 1/4-20 REGHEXCTRLK	2
21.	• 271172	NUT, 1/4-20 REGHEXKEPS	1
22.	• 271187	NUT, 5/16-24 HKEPS	2
23.	57444	TIE, CABLE BLACK NYLON 5.62 L	1
24.	55511	WIRE, GROUND, 12.5"	1
25.	• 271184	NUT, 5/16-18 HEXKEPS	1
26.	57547	SWITCH, SEAT	1
27.	• 160505	SCREW, 1/4-20 X .38 PHPNHMA	2
28.	302257	BATTERY, YUASA 12V 5-PLATE	1
29.	324719	BATTERY BRACKET	1
30.	40234	BATTERY ROD	2
31.	120392	WASHER, FLAT .281 X .63 X .065	2
32.	• 325232	WINGNUT, 1/4-20 NYLON	2
33.	• 120854	SCREW, 1/4-20 X .63 HHC	2
34.	• 271172	NUT, 1/4-20 REGHEXKEPS	2
35.	•• 302031	FUSE, 15 AMP SPADE TYPE	1

- INDICATES STANDARD HARDWARE ITEMS
- Spade type fuse included with the wire harness.

# 38" LAWN TRACTOR MODEL D3554-030

DECALS (DECORATIVE)

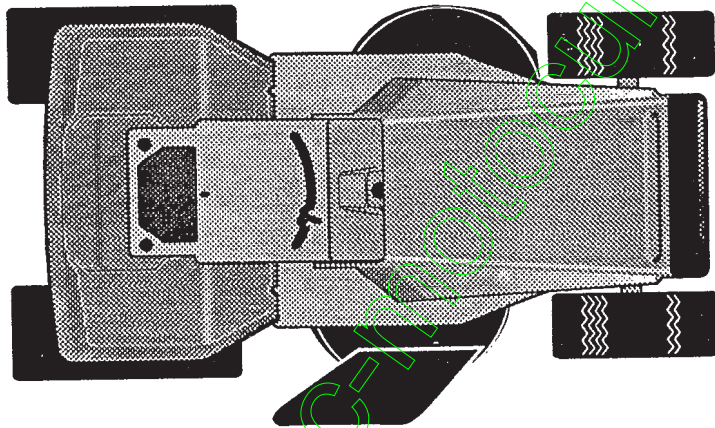
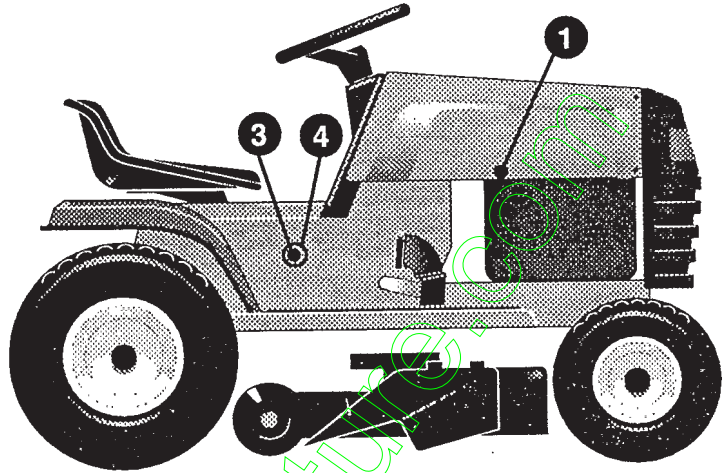
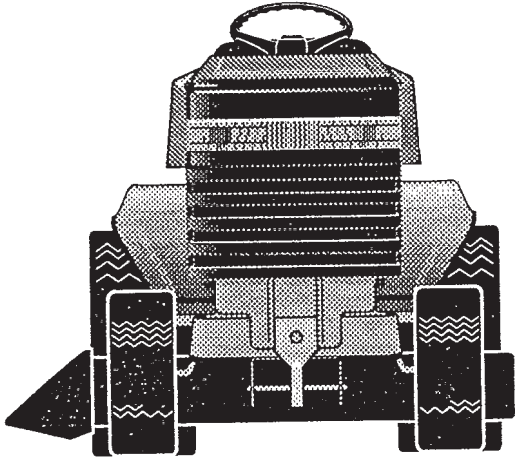

CONSOLE DETAIL

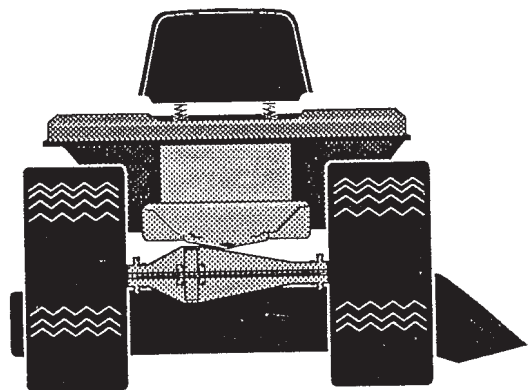
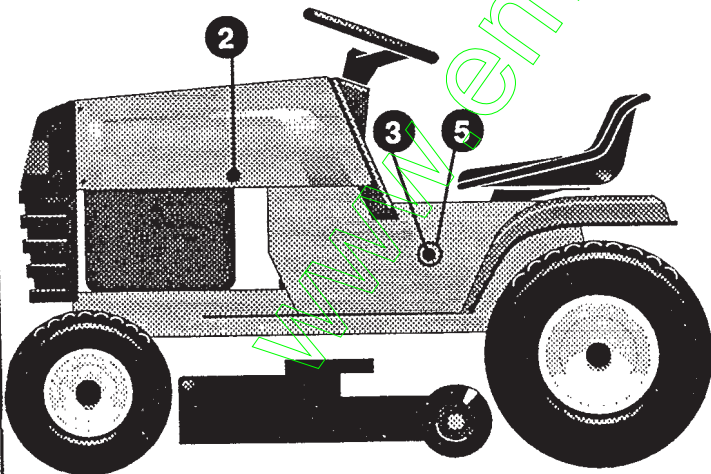
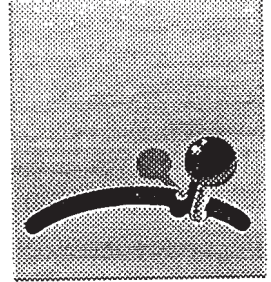

# 38" LAWN TRACTOR MODEL D3554-030

KEY#	PART#	DESCRIPTION	QTY.
1.	314456	DECAL, HOODSIDE RH H-21	1
2.	314457	DECAL, HOODSIDE LH H-21	1
3.	314208	NAMEPLATE, 12/38	2
4.	320872	DECAL, CONSOLE RH STRETCH FRM	1
5.	320873	DECAL, CONSOLE LH STRETCH FRM	1
6.		REFERENCE ONLY	

[www.emc-motoculture.com](http://www.emc-motoculture.com)

# 38" LAWN TRACTOR MODEL D3554-030

## DECALS (INSTRUCTIONAL)

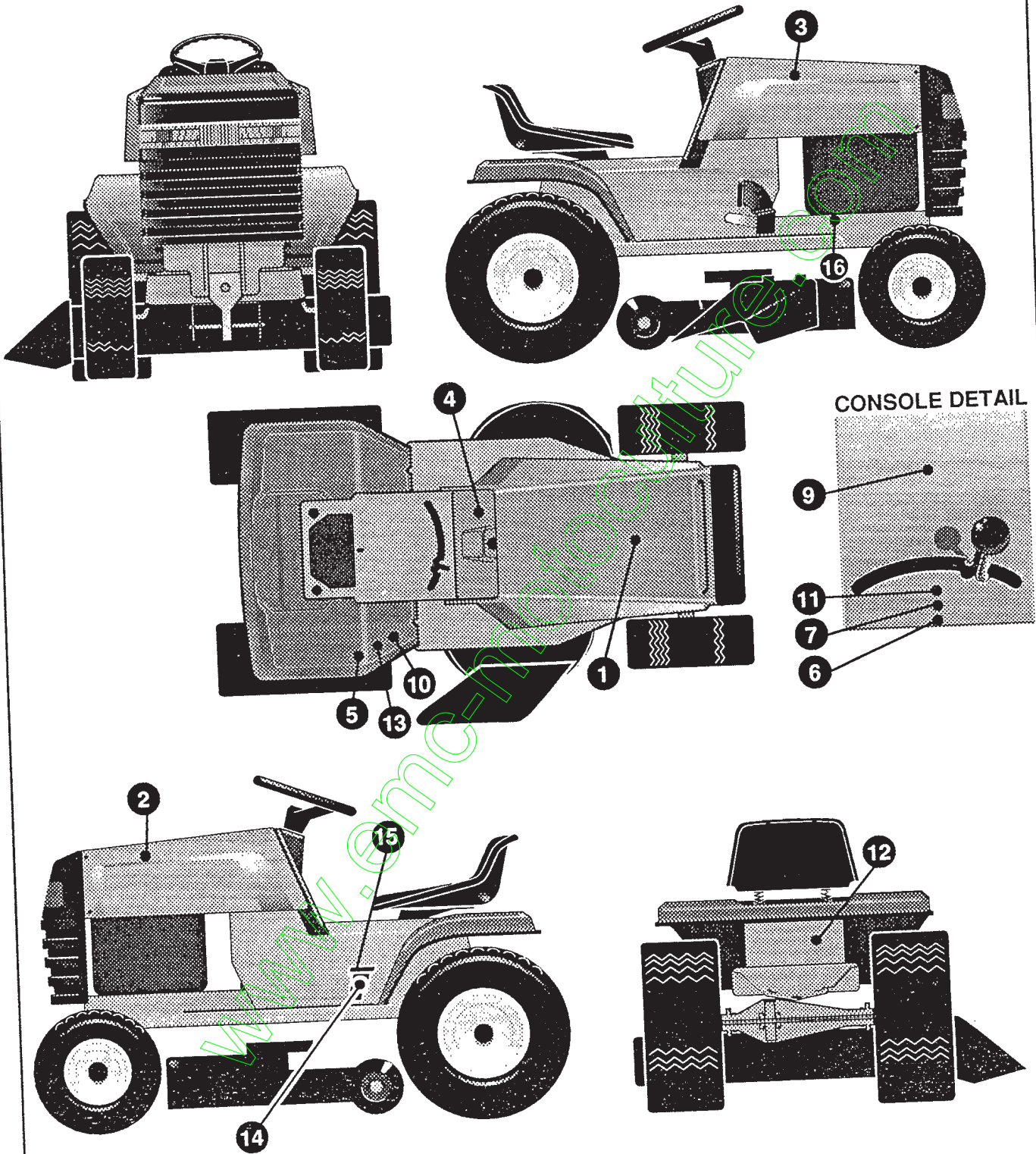

324809B

# 38" LAWN TRACTOR MODEL D3554-030

KEY#	PART#	DESCRIPTION	QTY.
1.	55832	PAD, FOAM TOP HOOD H-4	1
2.	55833	PAD, FOAM HOOD H-4 SIDE LH	1
3.	55834	PAD, FOAM HOOD H-4 SIDE RH	1
4.	324989	DECAL, DASH, DYNAMARK	1
5.	68902	DECAL, WARNING, FRENCH/GERMAN	1
6.	69524	DECAL, INSTRUCT CONSOLE TOP GER	1
7.	69525	DECAL, INSTRUCT CONSOLE TOP FR	1
8.		REFERENCE ONLY	
9.	301104	DECAL, CONSOLE TOP SHIFT 5-SP	1
10.	305770	DECAL, CAUTION TRIANGLE EUROPE	1
11.	307383	DECAL, INSTRUCT CONSOLE TOP ENGL	1
12.	310436	DECAL, FRENCH SAFETY CERT.	1
13.	310553	DECAL, DANGER ENGLISH	1
14.	320892	DECAL, INSTRUCT PEDAL LIFT	1
15.	327146	DECAL, PEDAL-LIFT INDICATOR	1
16.	68903	DECAL, BRAKE/CLUTCH EUROPE	1

[www.emc-motoculture.com](http://www.emc-motoculture.com)

# 38" LAWN TRACTOR MODEL D3554-030

## CUSTOMER ASSEMBLY

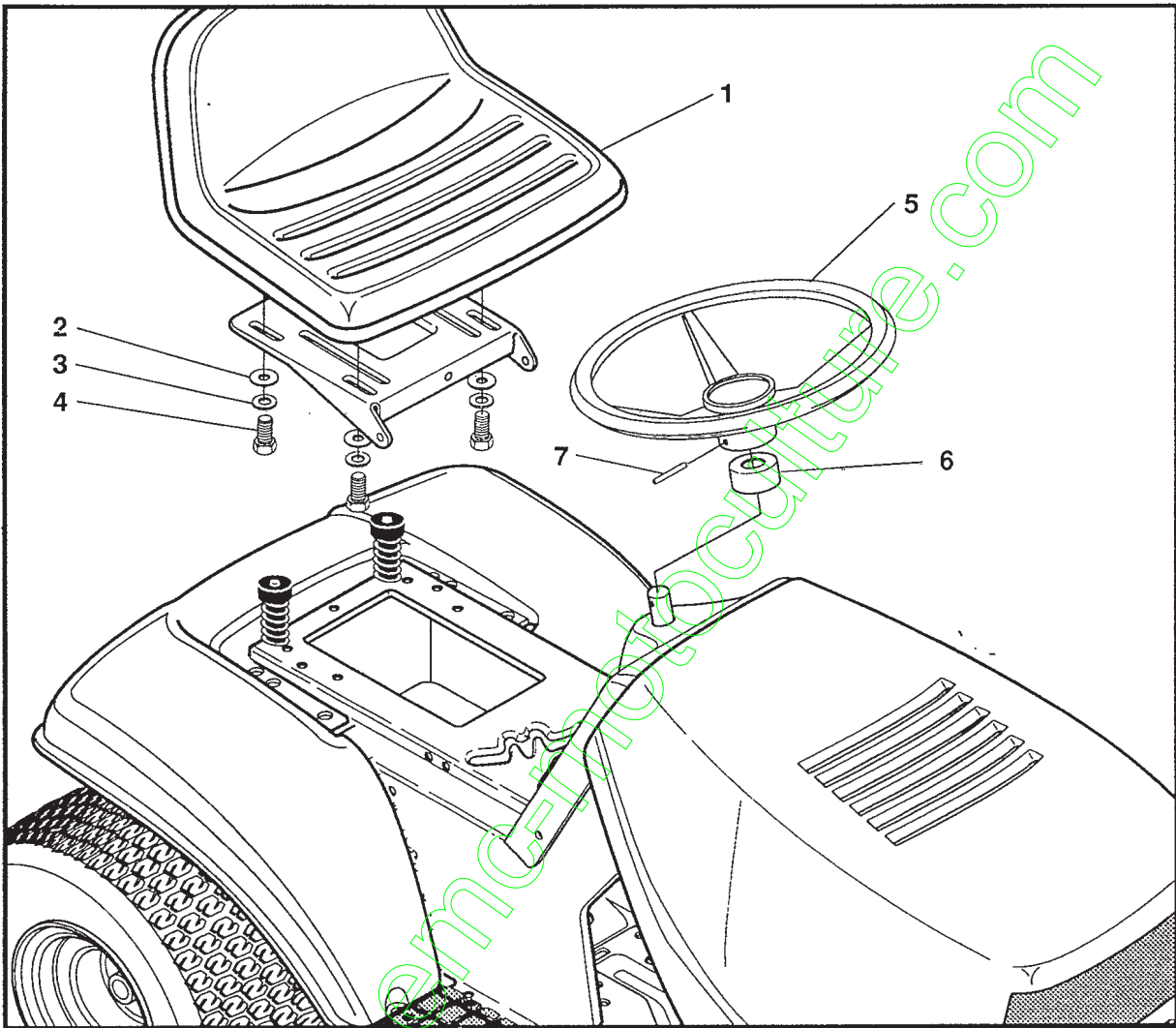

## CUSTOMER ASSEMBLY VIEW

315134 PARTS BAG ASSY QTY1

KEY#	PART#	DESCRIPTION	QTY
1	57452	SEAT MV350	1
2	120393	WASHER, FLAT .344X.69X.065	4
3	120638	WASHER, HVSPLTLK .328X.60X.109	4
4	122007	SCREW, 5/16-18X.75 HHC	4
5	301251	STEERING WHEEL	1
6	323758	STEERING, SLEEVE	1
7	456378	ROLL PIN .250DIA X 2.0LG	1

# 38" LAWN TRACTOR MODEL D3554-030

## TREAD PATTERNS

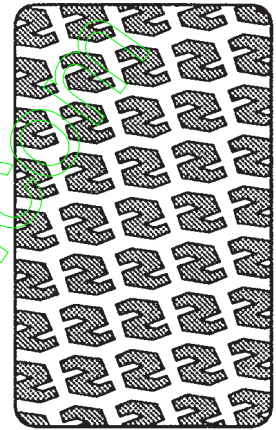
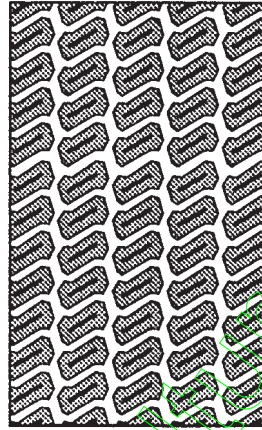
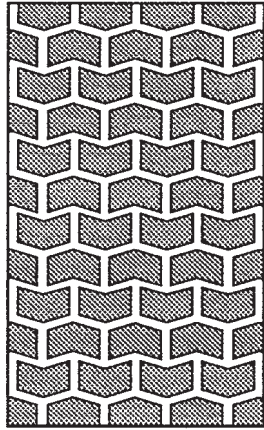
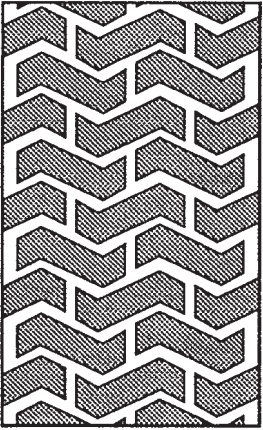

"A"

"B"

"C"

"D"

**TIRE SIZE**

TIRE SIZE	"A"	"B"	"C"	"D"
11 X 4.00 - 5	42295	319679		
13 X 5.00 - 6	41060	319680		
15 X 6.00 - 6	39830	316702	301140	313952
16 X 6.50 - 8	41081	319682		314539
18 X 8.50 - 8	319683	317400		
18 X 9.50 - 8	41106	316701		313950
20 X 8.00 - 8	319685	319684	57164	314584
20 X 10.00 - 8	58276	319686		313654
20 X 10.00 - 10	55893	319687		
23 X 9.50 - 12	53655	319690	319689	314370

www.cmc-motocycle.com

## ACCESSORIES

Contact the dealer where your tractor was purchased for the available accessories. If you are unable to contact the dealer, write to the address on the front cover of this manual.

### Rear Engine Rider

Model	Description
5708-16	Bagger - Fits 32" Side Discharge
5708-17	Bagger - Fits 36" Side Discharge & 30" Top Discharge
5709-02	Front Weight Box - holds 35 lbs.
5648-16	Lawn Sweeper w/dump Release
5714-00	Mulching Kit - 30" Top Discharge

### Lawn Tractor

Model	Description
5708-22	Bagger - Fits 30" Side Discharge
5708-13	Bagger - Fits 36", 38", 39' & 45" Side Discharge
5705-04	36" Two-Stage Snowblower - Fits 36", 38", 39", & 45" Side Discharge
5661-06	42" Snowblade - Fits 36", 38", 39", & 45"
5592-00	Tire Chains - 18" x 6.50"
5585-00	Tire Chains - 18" x 9.50" & 20" x 8"
5672-01	Wheel Weights - Front - 1 pr. w/mtg. hdw. - Fits 15" tires
5673-02	Wheel Weights - Rear - 1 pr. w/mtg. hdw. - Fits 18" & 20" tires
5709-03	Front Weights - Fits 30" & 32" Side Discharge
5648-16	Lawn Sweeper w/dump Release
5714-00	Mulching Kit - 30" Top Discharge

### Garden Tractor - Light Ground Engaging

Model	Description
5708-13	Bagger - Fits 36", 38", 39", & 45" Side Discharge
5705-04	36" Two - Stage Snowblower - Fits 36", 38", 39", & 45"
5661-06	42" Snowblade - Fits 36", 38", 39", & 45"
5672-01	Wheel Weights - Front 1 pr. w/mtg. hdw. - Fits 15" tires
5673-02	Wheel Weights - Rear - 1 pr. w/mtg. hdw. - Fits 18" & 20" tires
5648-16	Lawn Sweeper w/dump Release
5667-02	Sleeve Hitch - w/lift bar - Fits 45"
5668-01	Adaptor (sleeve hitch) for use w/23" tires
5706-00	Tire Chains - 20" x 10"
5671-00	Tire Chains - 23" x 9.50"
5672-02	Wheel Weights - Front - 1 pr. w/mtg. hdw. Fits 16" tires
5673-00	Wheel Weights - Rear - 1 pr. w/mtg. hdw. Fits 23" tires
5674-01*	10" One Bottom Moldboard Plow
5675-01*	Cultivator - 7 row - Adj. 6" - 42" width
5676-01*	Disc Harrow - 8" & 11" disc - Adj. width & disc angle
5677-02*	Tiller - 5 H.P. Self-Powered - 28" width

### Four Wheel Steer

Model	Description
5708-14	Bagger - Fits 40" & 46" Side Discharge
5705-05	42" One-Stage Snowblower - Fits 40" & 46"
5661-07	48" Snowblade - Fits 40" & 46"
5709-04	Rear Weight Box for 40" & 46"
5648-16	Lawn Sweeper w/dump Release
5706-00	Tire Chains 20" x 10"
5671-00	Tire Chains 23" x 9.50"
5672-02	Wheel Weights - Front - 1 pr. w/mtg. hdw. Fits 16" tires
5673-00	Wheel Weights - Rear - 1 pr. w/mtg. hdw. Fits 23" tires
5672-01	Wheel Weights - Front - 1 pr. w/mtg. hdw. Fits 15" tires
5673-02	Wheel Weights - Rear - 1 pr. w/mtg. hdw. Fits 18" & 20" tires

### Two Wheel Steer Garden Tractor

Model	Description
5667-04	Sleeve Hitch - w/lift bar Fits 46"
5674-01*	10" One Bottom Moldboard Plow
5675-01*	Cultivator - 7 row - Adj. 6" - 42" width
5676-01*	Disc Harrow 8" & 11" Disc. Adj. width & disc angle
5677-02*	Tiller 5 H.P. Self-Powered - 28" width
5648-16	Lawn Sweeper w/dump Release

\*Requires a sleeve hitch