

Texas 1239Q 1993

REPAIR PARTS MANUAL

39" - 12 H.P. LAWN TRACTOR

MODEL D3554-180

Ordering set fr. Geo 334169

ONE YEAR LIMITED WARRANTY

For one (1) year from date of purchase by the first consumer for residential use (thirty (30) days commercial use), NOMA Outdoor Products Incorporated warrants that it will replace free of charge, including labor, any original part of any NOMA Outdoor Products Incorporated product found to be defective by any authorized Service Dealer or the factory, except the battery which is warranted for ninety (90) days from date of purchase.

This warranty does not cover engine, transmission, transaxle or differential (these items are covered by their manufacturer's own warranty). This warranty does not cover parts that have failed due to normal wear or parts that have failed subject to misuse or abuse. Transportation of the unit or part to and from an authorized Service Dealer or factory is the responsibility of the owner.

A step by step explanation as to what procedure should be followed for this warranty is:

1. If a part becomes defective, contact the store where the unit was purchased for the name and address of the authorized Service Dealer nearest to you.
2. If you cannot locate an authorized Service Dealer, write Service Department of NOMA Outdoor Products Incorporated for the name and address of the authorized Service Dealer in your area or call the Service Department at 1-901-422-1690.
3. Return the defective product, along with proof of purchase to such authorized Service Dealer for replacement of any defective part where covered by this warranty.

There is no other express warranty. Implied warranties, including those of merchantability and fitness for a particular purpose are limited to one (1) year from date of purchase. Liability for incidental or consequential damages are excluded.

Some states do not allow limitations on how long an implied warranty lasts, so the above limitation may not apply to you. Some states do not allow the exclusion of incidental or consequential damages, so the above exclusion may not apply to you. This warranty gives you specific legal rights, and you may have other rights which vary from state to state.

NOMA Outdoor Products Incorporated

Caller 8000

Jackson, TN 38308-8000

UNIT PARTS AND SERVICE

Fill in and mail the registration card packed with the unit. For service other than covered in this manual, contact an authorized service dealer. A nationwide parts and service organization has been established to provide locally available parts and service. A list of authorized parts distributors has been included in this manual. When ordering repair parts, always give the following information: 1. The Part Name; 2. The Part Number; 3. The Quantity desired; 4. The Full (eight digit) Model Number of the unit. The model number will be found on a plate attached to the unit.



Look for this symbol.

It means - **ATTENTION! BECOME ALERT! A HAZARD TO OPERATOR, BYSTANDER, PROPERTY OR EQUIPMENT MAY EXIST.**

NOMA Outdoor Products Incorporated
Caller 8000
Jackson, TN 38308-8000

Part No. 328971A

50/92

DUE TO AN ERROR, THE MOWER SUSPENSION PAGES WERE LEFT OUT OF YOUR MANUAL. PLEASE PLACE THESE PAGES IN YOUR MANUAL FOR FUTURE REFERENCES.

39" LAWN TRACTOR MODEL D3554-180

MOWER SUSPENSION

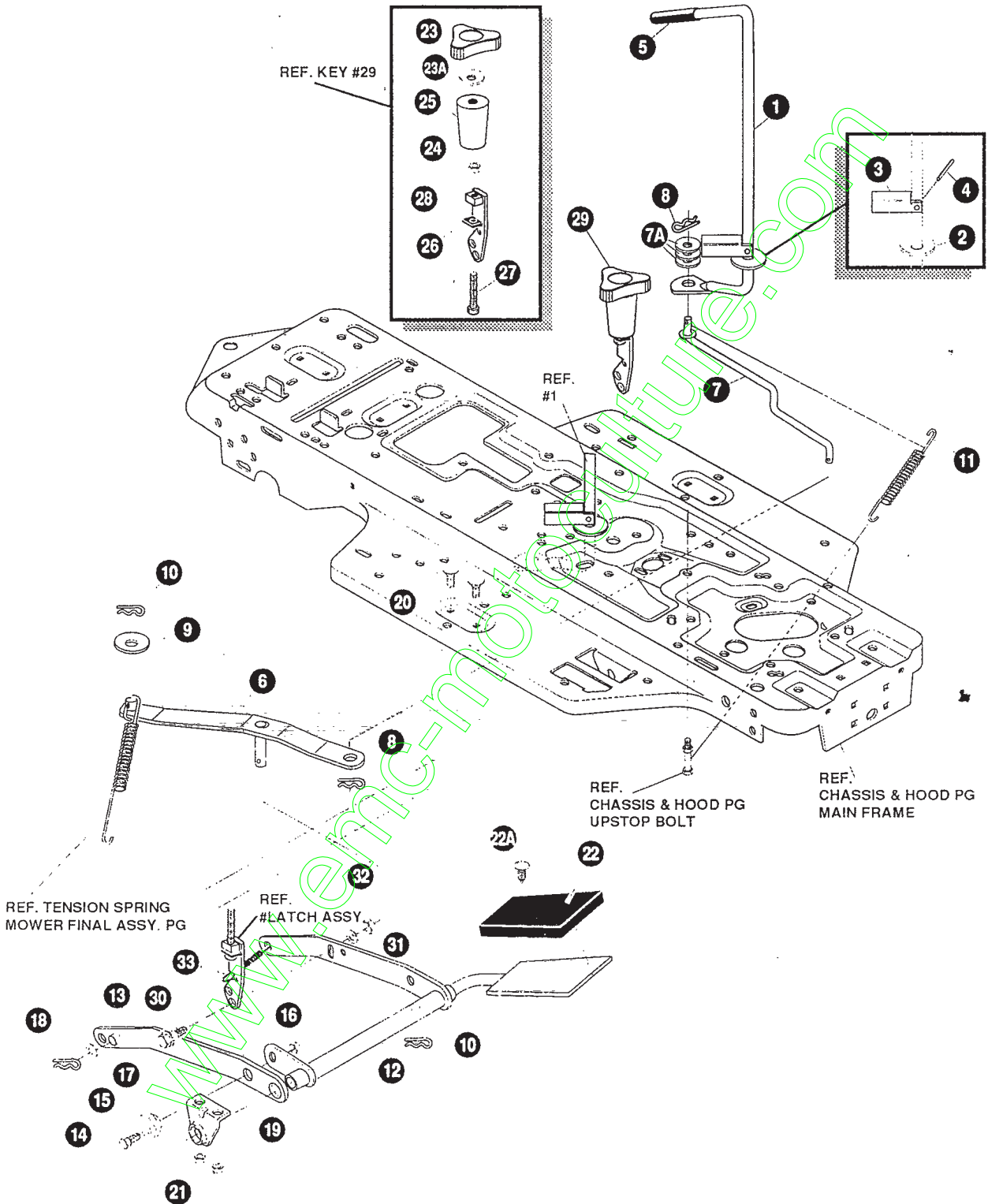

NOTE: ALWAYS USE ORIGINAL EQUIPMENT PARTS.
Use of service/replacement parts other than original equipment parts may void your warranty.

**ALL UNNUMBERED
ITEMS ARE INTERCHANGEABLE
WITH OPPOSITE SIDE**

327602D

DUE TO AN ERROR, THE MOWER SUSPENSION PAGES WERE LEFT OUT OF YOUR MANUAL. PLEASE PLACE THESE PAGES IN YOUR MANUAL FOR FUTURE REFERENCES.

39" LAWN TRACTOR MODEL D3554-180

KEY#	PART#	DESCRIPTION	QTY.
1	325592	HANDLE, RH PTO GPDASH SF	1
2	22265	WASHER, FLAT .515X1.38X.119PL	1
3	305225	ML STOP, PTO ENGAGEMENT	1
4	326386	PIN, SPRING, 187DIA X1.13LG HD	1
5	46478	GRIP, HAND .50ID 3.37 LG BLK	1
6	325587	WS STRAP ASSY, PTO BELCRANK SF	1
7	325590	ROD, BELCRANK LINK	1
7A	274517	WASHER, FLAT .406X.73X.063	3
8	8260	PIN, HAIR .091 DIA X1.66LGZ	2
9	25210	WASHER, FLAT .392X1.25X.09	1
10	8260	PIN, HAIR .091 DIA X1.66LGZ	2
11	325802	SPRING, .69X7.75X.0897 TENSION	1
12	326533-853	WP LIFT ASSY, LH PEDAL-LIFT	1
13	325130-853	WP LIFT ASSY, RH SF	1
14	180079	• SCREW, 5/16-18X1.00 HHC GR5 Z	1
15	58247	• NUT, ADJUST	1
16	1498	• NUT, 5/16-18 REGHEXCTRLK Z	1
17	417098	WASHER, FLAT .531X1.06X.063Z	2
18	8260	PIN, HAIR .091 DIA X1.66LG	2
19	325495-853	MP BRACKET, REAR HANG SUSP	1
20	126211	BOLT, 5/16-18X.63 CARR GR2Z	4
21	1498	• NUT, 5/16-18 REGHEXCTRLK	4
22	328596	PAD, LIFT PEDAL	1
22A	309235	FASTENER, RATCHET	1
23	325860	KNOB, FLUTED TORQUE BLACK	1
23A	446363	WASHER, FLAT .375X.88X.082	1
24	45905	• NUT, 3/8-16 HWDFLLK MACK Z	1
25	326113	COVER, TOP SLEEVE PEDAL-LIFT	1
26	324983	WASHER, RUBBER 3/8X.75SQ	1
27	325832	• BOLT, SUS MOWER LATCH SF	1
28	325831-853	WP LATCH, SUS MOWER SF	1
29	327934	MOWER, ASM LATCH SUS	1
30	25086	• BOLT, .500X.375 HSSH 5/16-18Z	1
31	4230	WASHER, FLAT .328X.68X.104	1
32	1498	• NUT, 5/16-18 HWDFLCTRLK	1
33	35410	SPRING, .071X.62X4.37	1

• STANDARD HARDWARE ITEMS

39" LAWN TRACTOR MODEL D3554-180

CHASSIS & HOOD ASSEMBLY

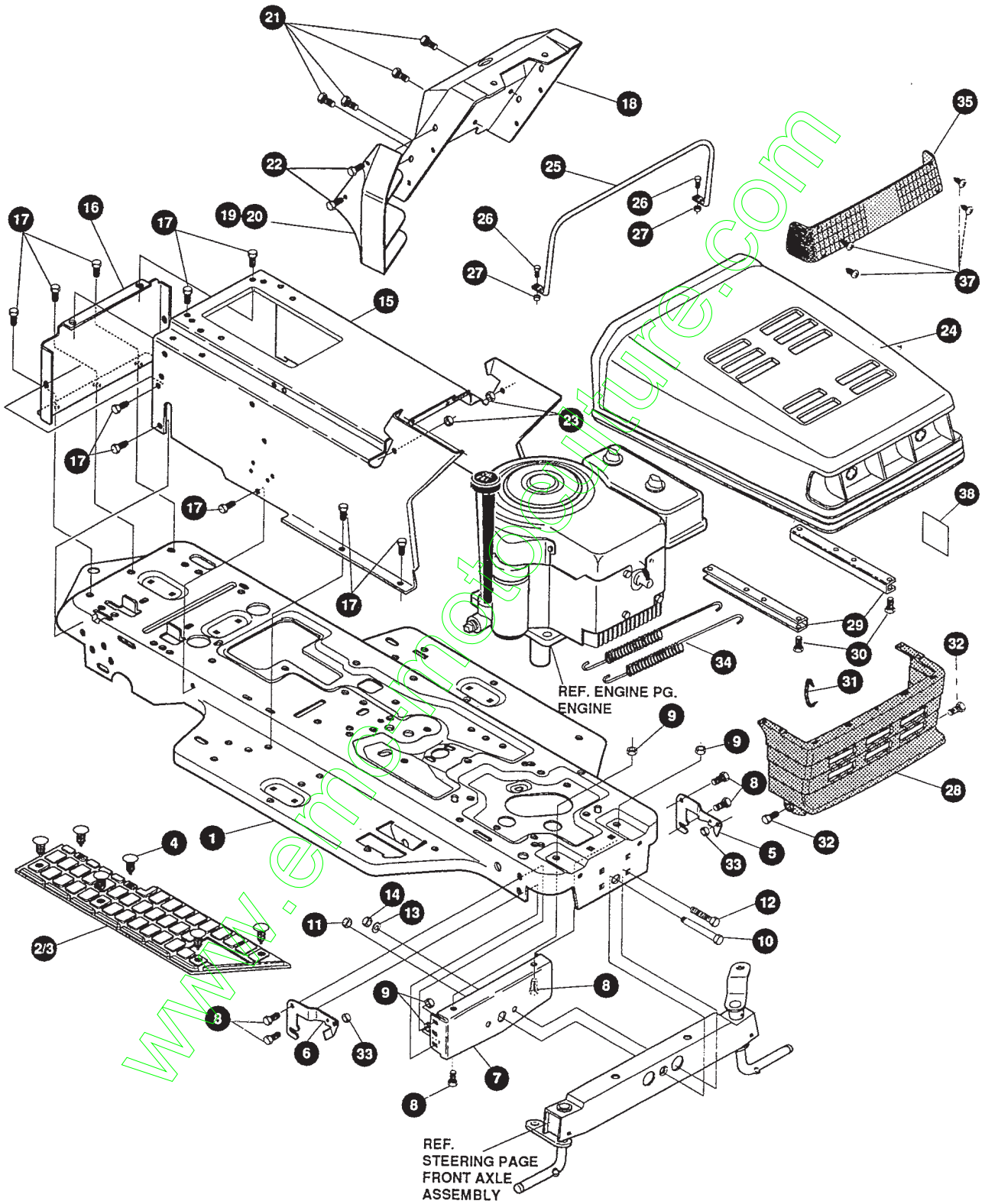

NOTE: ALWAYS USE ORIGINAL EQUIPMENT PARTS. Use of service/replacement parts other than original equipment parts may void your warranty.

ALL UNNUMBERED ITEMS ARE INTERCHANGEABLE WITH OPPOSITE SIDE

327914C

39" LAWN TRACTOR MODEL D3554-180

KEY#	PART#	DESCRIPTION	QTY.
1	321997-889	FRAME, MAIN SF RIDER	1
2	326731	FOOTPAD,LH SF MOLDED	1
3	310004	FOOTPAD,RH SF MOLDED	1
4	309235	FASTENER, RATCHET	12
5	313003-853	BRKT.GRILLE, L.H.	1
6	313004-853	BRKT GRILLE R.H.	1
7	56362-853	BRACKET, SUPT FRT AXLE-SF	1
8	328154	SCREW, 5/16-18X1.00WDFLLK GR5	6
9	• 55273	NUT, 5/16-18 HXWDFLLK	6
10	29616	BOLT, .625 X 1.890 SPSH 1/2-20	1
11	• 274654	NUT, 1/2-20 REGHXCTRLK	1
12	• 122201	SCREW, 3/8-16X2.75 HHC	2
13	2483	WASHER, 39IDX1.25DX.07	2
14	• 1499	NUT, 3/8-16 REGHXCTRLK	2
15	309584-889	CONSOLE, SF GPWR NOTCHED TOP	1
16	56235-889	CONSOLE REAR COVER	1
17	• 995346	SCREW, 1/4-20 X .50 WAHHTAP	15
18	321980-853	DASH, SM.FR. W/O AMMET GPWR	1
19	302723	INSERT,DASH LH 11 HP	1
20	302724	INSERT,DASH RH 11 HP	1
21	• 995338	SCREW, 1/4-20X.63HHWATAP	4
22	• 274672	SCREW,1.4-20X.63 WAHHC	4
23	51335	NUT, 1/4-20 WDFLLK	4
24	311762	HOOD H-12 PLASTIC	1
25	307278	SUPPORT HOOD H-12 GP 11 HP	1
26	• 301542	SCREW, 10-24X1.00HWATAP	4
27	• 271166	NUT, #10-24 HEXKEPS	4
28	302722	GRILL, G-15 GPWR SM LWR	1
29	9783	BRACKET, TIE HOOD	2
30	• 35055	SCREW, 10-24X.50 SLHWATAP	8
31	310203	CLIP HOG RING	1
32	56676	BOLT, .375X.580 HSSH 5/16-18	2
33	• 1498	NUT, 5/16-18 REGHEXCTRLK	2
34	57478	SPRING, HOOD LATCH	2
35	305716	LENS 11 HP HAKO SMOKED	1
37	57796	SCREW, #6X.50 PLASTITE	4
38	301452	FOIL, HEAT REFLECTOR	1
39	328971	PARTS MANUAL	1
40	328972	OPERATOR'S MANUAL (DANISH)	1
41	326325	MULCHING KIT	1

• INDICATES STANDARD HARDWARE ITEMS.

39" LAWN TRACTOR MODEL D3554-180

CHASSIS & HOOD ASSEMBLY

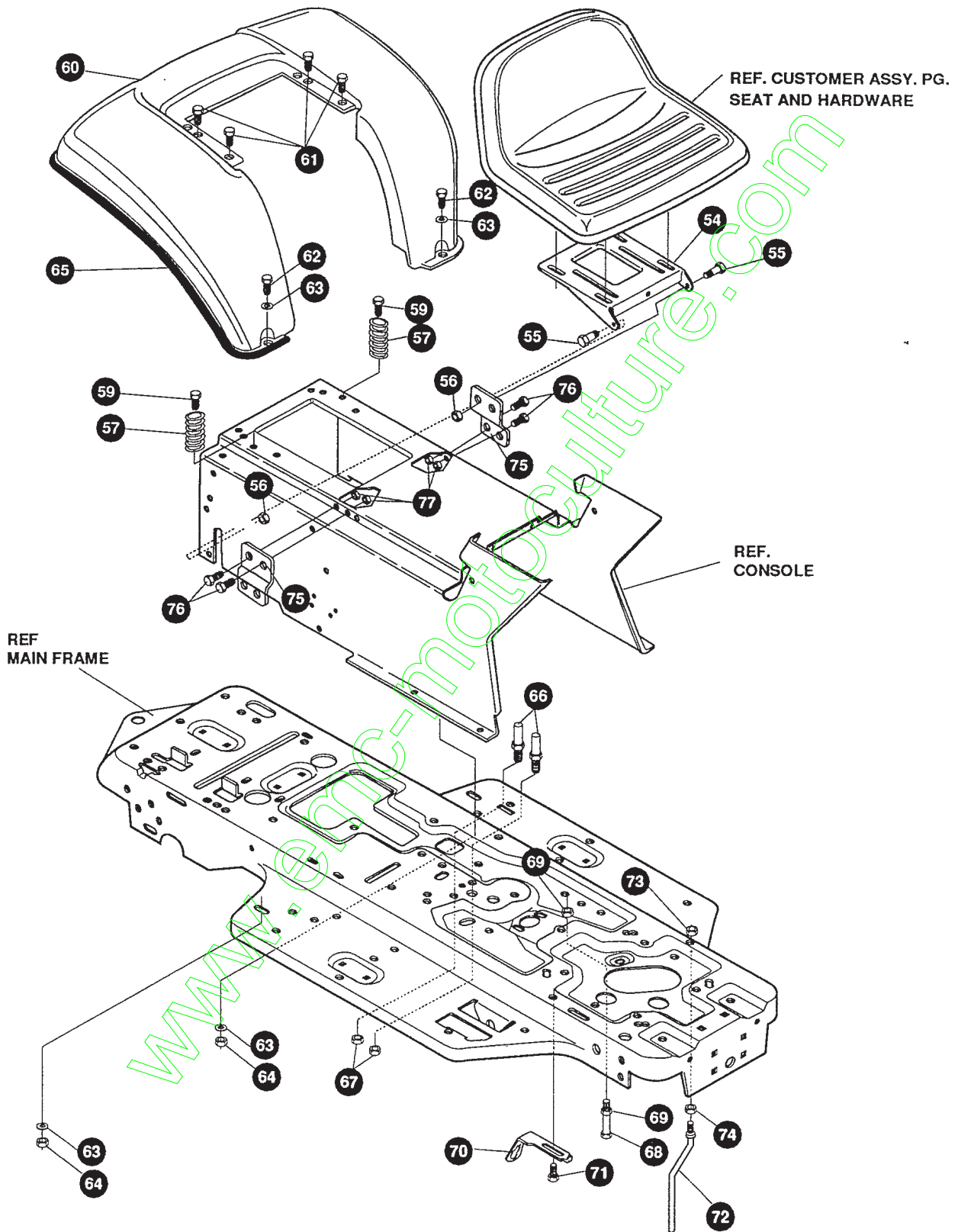

NOTE: ALWAYS USE ORIGINAL EQUIPMENT PARTS. Use of service/replacement parts other than original equipment parts may void your warranty.

ALL UNNUMBERED ITEMS ARE INTERCHANGEABLE WITH OPPOSITE SIDE

327914C

39" LAWN TRACTOR MODEL D3554-180

KEY#	PART#	DESCRIPTION	QTY.
54	58367-889	PLATE, SEAT	1
55	20507	BOLT, .437X.156 HSH 5/16-18	2
56	• 1498	NUT, 5/16-18 REGHEXCTRLK	2
57	328392	SPRING, 1.43X2.38X.162	2
59	• 995346	SCREW, 1/4-20X.50 WAHTAP	2
60	309421-889	FENDER F-5	1
61	• 995346	SCREW, 1/4-20 X .5 WAHTAP	4
62	• 122017	SCREW, 5/16-18X1.00 HHC	2
63	446363	WASHER, FLAT .375X.88X.082	4
64	• 1498	NUT, 5/16-18 REGHEXCTRLK	2
65	55023	TRIM, STRIP	77.5
66	53446	PIN, 5/16-18	2
67	• 271184	NUT, 5/16-18 HEXKEPS	2
68	• 427342	SCREW, 3/8—16 X 6.50 HHC	1
69	• 1499	NUT, 3/8-16 REGHXCTRLK	2
70	302610-853	BRACKET SWITCH MOUNT	1
71	• 995346	SCREW, 1/4-20X.50 WAHTAP	1
72	50653	GUIDE, BELT	1
73	• 41529	NUT, 3/8-16 HXCTRLKJAN GRD	1
74	• 271190	NUT, 3/8-16 HEXKEPS	1
75	328393-889	SEAT BRACKET	2
76	180075	SCREW, 5/16-18X.63 HHC GR2	4
77	1498	NUT, 5/16-18 REGHEXCTRLK	4

• INDICATES STANDARD HARDWARE ITEMS

www.emc-motoculture.com

39" LAWN TRACTOR MODEL D3554-180

STEERING ASSEMBLY

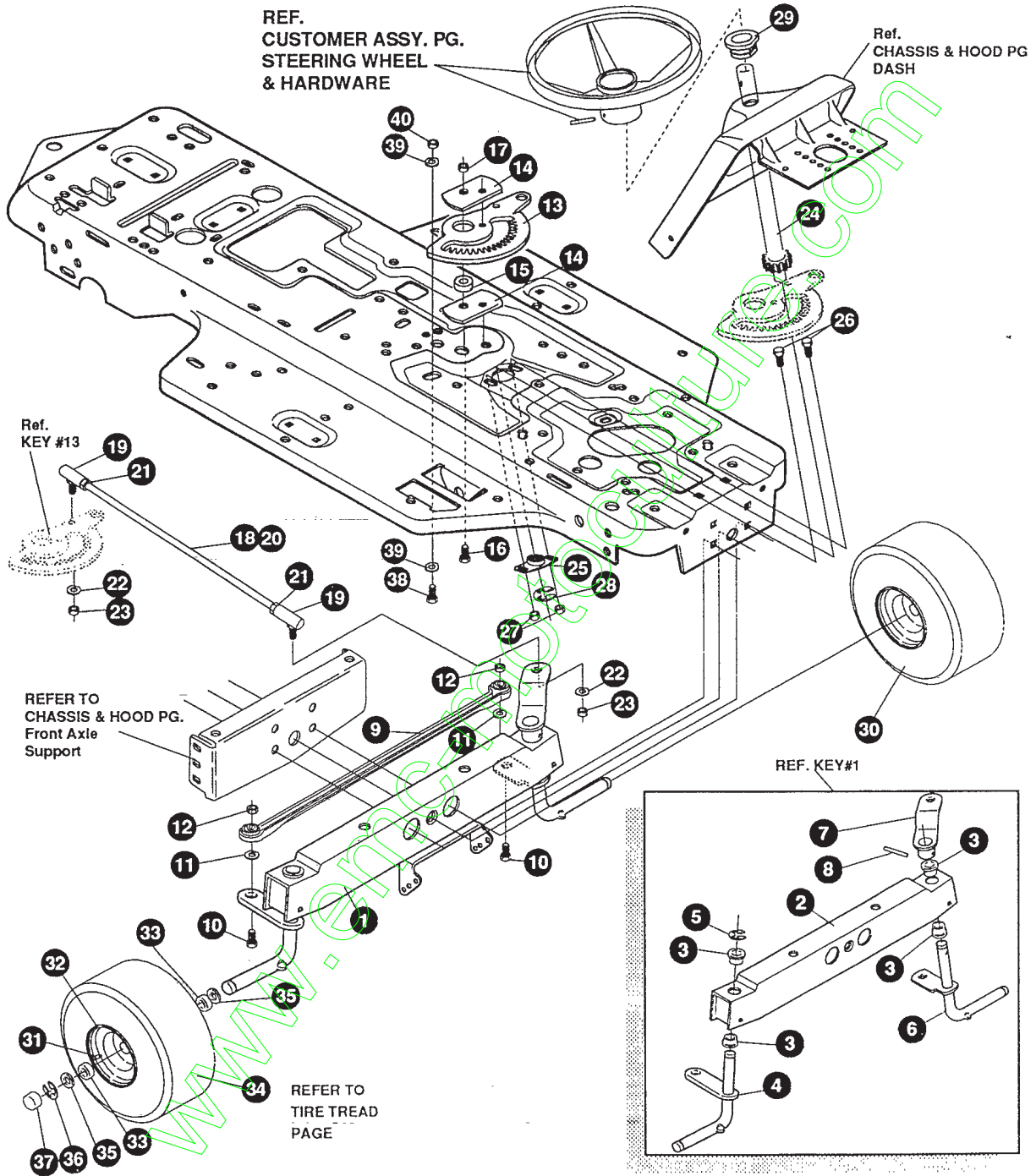

NOTE: ALWAYS USE ORIGINAL EQUIPMENT PARTS. Use of service/replacement parts other than original equipment parts may void your warranty.

ALL UNNUMBERED ITEMS ARE INTERCHANGEABLE WITH OPPOSITE SIDE

327592D

39" LAWN TRACTOR MODEL D3554-180

KEY#	PART#	DESCRIPTION	QTY.
1	^	FRONT AXLE ASSEMBLY SF	1
2	324915-889	AXLE, FRONT	1
3	50546	BEARING, FLANGE	4
4	310368	SPINDLE, RH	1
5	36625	RING, RETEX	1
6	310367	SPINDLE, LH	1
7	325223-853	ARM, STEERING LH	1
8	454565	PIN, SPRING	1
9	302688	TIE ROD	1
10	◇ 122145	SCREW, 3/8-16X1.25 HHC	2
11	◇ 120382	WASHER, .393X.68X.10 REGSPTLK	2
12	◇ 1499	NUT, 3/8-16 REGHCTRLK	2
13	324752	SECTOR, GEAR	1
14	327833	PLATE SECTOR SF 4WS	2
15	324753	BUSHING SECTOR GEAR SF 4WS	1
16	180124	SCREW, 3/8-16X1.25	1
17	1499	NUT, 3/8-16 REGHXCTRLK	1
18	◇ 328808	DRAGLINK ASSEMBLY	1
19	57158	BALL JOINT	2
20	56190	DRAGLINK	1
21	124925	NUT, 3/8-24 REGHEXJAM	2
22	120382	WASHER, REGSPTLK	2
23	120369	NUT, 3/8-24 REGHEX	2
24	327690	SHAFT PINION STEERING	1
25	325692	BRG. FL	1
26	326505	SCREW, 1/4-20X.75 GRD 5	2
27	46931	NUT, 1/4-20 FLLK NUT SIDE LOCK	2
28	20864	RING RET E	1
29	54902	BRNG, FL .753IDX1.37ODX.50	1
30	^	ASSEMBLY TIRE	2
31	24167	VALVE STEM	1
32	39829	WHEEL W/BEARING	1
33	314416	BEARING, 1.38ODX.753ID FLANGE	2
34		REFER TO TIRE TREAD PAGE	
35	642	WASHER, FLAT .755X1.31X.075	4
36	36625	RING, RETEX .57X.05	2
37	40394	HUB CAP	2
38	122145	SCREW, 3/8-16X1.25 GRD2	1
39	120394	WASHER, FLAT 406X.81X.065	2
40	44374	NUT, 3/8-16 HXWDFLLK	1

◇ INDICATES STANDARD HARDWARE ITEMS.
 ^ ORDER INDIVIDUAL PARTS.

39" LAWN TRACTOR MODEL D3554-180

MOTION DRIVE ASSEMBLY

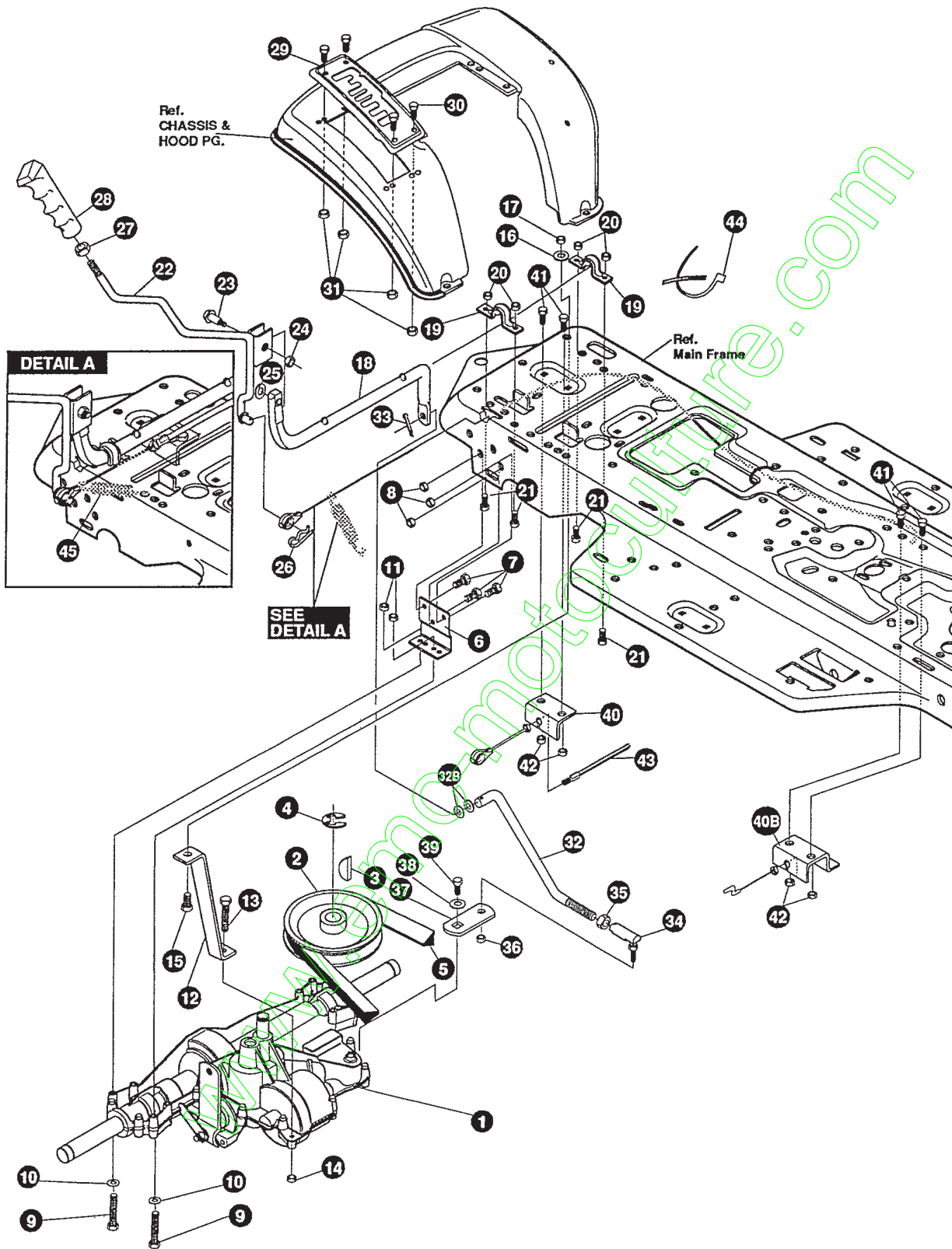

NOTE: ALWAYS USE ORIGINAL EQUIPMENT PARTS. Use of service/replacement parts other than original equipment parts may void your warranty.

ALL UNNUMBERED
ITEMS ARE INTERCHANGEABLE
WITH OPPOSITE SIDE

328927D

39" LAWN TRACTOR MODEL D3554-180

KEY#	PART#	DESCRIPTION	QTY.
1.	*	TRANSAXLE 940-007 2WS,LF,SF	1
2.	302745	PULLEY, IDLER V4L 6.60X	1
3.	3021	KEY, WDRF 606 .750X.187X.312	1
4.	22053	RING, RETEX .58X.035TRU5100-62	1
5.	54758	BELT, V 4L 82.00SF DRIVE	1
6.	53768-853	BRACKET, TRANSAXLE	2
7.	120228	SCREW, 5/16-18X .63 HHC	6
8.	1498	NUT, 5/16-18 REGHEXCTRLK	6
9.	180089	SCREW, 5/16-18X2.25 HHC	4
10.	120393	WASHER, FLAT .344X .69X.065	4
11.	1498	NUT, 5/16-18 REGHEXCTRLK	4
12.	323213	BRACKET, T/A TORQ. 915 S/F	1
13.	180087	SCREW, 5/16-18X2.00 HHC GR5	1
14.	1498	NUT, 5/16-18 REGHEXCTRLK	1
15.	122017	SCREW, 5/16-18X1.00 HHC	1
16.	138485	WASHER, EXLK .320X.61X.03	1
17.	1498	NUT, 5/16-18 REGHEXCTRLK	1
18.	325793	ML LEVER, SHIFT LOWER	1
19.	302760	MS,MF CLAMP .625DIA	2
20.	1498	NUT, 5/16-18 REGHEXCTRLK	4
21.	180075	SCREW, 5/16-18X .63 HHC	4
22.	320383	WP UPPER SHIFT LEVER ASM. SOG	1
23.	321092	BOLT, .380X .500 HHSX 1/4-20	1
24.	50352	NUT, 1/4-20 WDFLLK TOPLOCK	1
25.	6106	WASHER, FLAT .515X.94X.104YZ	1
26.	36368	PIN, HAIR .072 DIA X1.13LG	1
27.	120377	NUT, 3/8-16 REGHX	1
28.	306689	HANDLE, 3/8-16	1
29.	320228-853	QUADRANT, SOG, P940-5 SPD SF	1
30.	305850	SCREW, 1/4-20X.50PHPNTAP	4
31.	1502	NUT, 1/4-20 REGHEXCTRLK	4
32.	327806	ROD, CONNECTING, SHIFT	1
32B.	120388	WASHER, FLAT .438X1.00X.083	2
33.	137185	PIN, COTTER .125 DIA X1.00LG	1
34.	57158	BALL JOINT, RH 3/8-24	1
35.	124925	NUT, 3/8-24 REGHEXJAM	1
36.	412349	NUT, 3/8-24 HXCTRLK	1
37.	323212	LF BRKT, SHIFT S/F	1
38.	57157	WASHER, .750X.250 SP	1
39.	56255	SCREW, 1/4-28X .75 NYLHHC	1
40.	321517	BRKT, FRAME, SHIFT N GO	1
40B.	300698-853	BRKT. CABLE	1
41.	1502	NUT, 1/4-20 REGHEXCTRLK	4
42.	120706	SCREW, 1/4-20X .50 HHC	4
43.	328226	CABLE, SHIFT N GO SF	1
44.	57444	TIE CABLE BLACK NYLON 54.62L	1
45.	314837	SPRING, MEMORY	1

* CONTACT YOUR NEAREST TRANSAXLE DEALER FOR PARTS AND SERVICE.

39" LAWN TRACTOR MODEL D3554-180

MOTION DRIVE ASSEMBLY

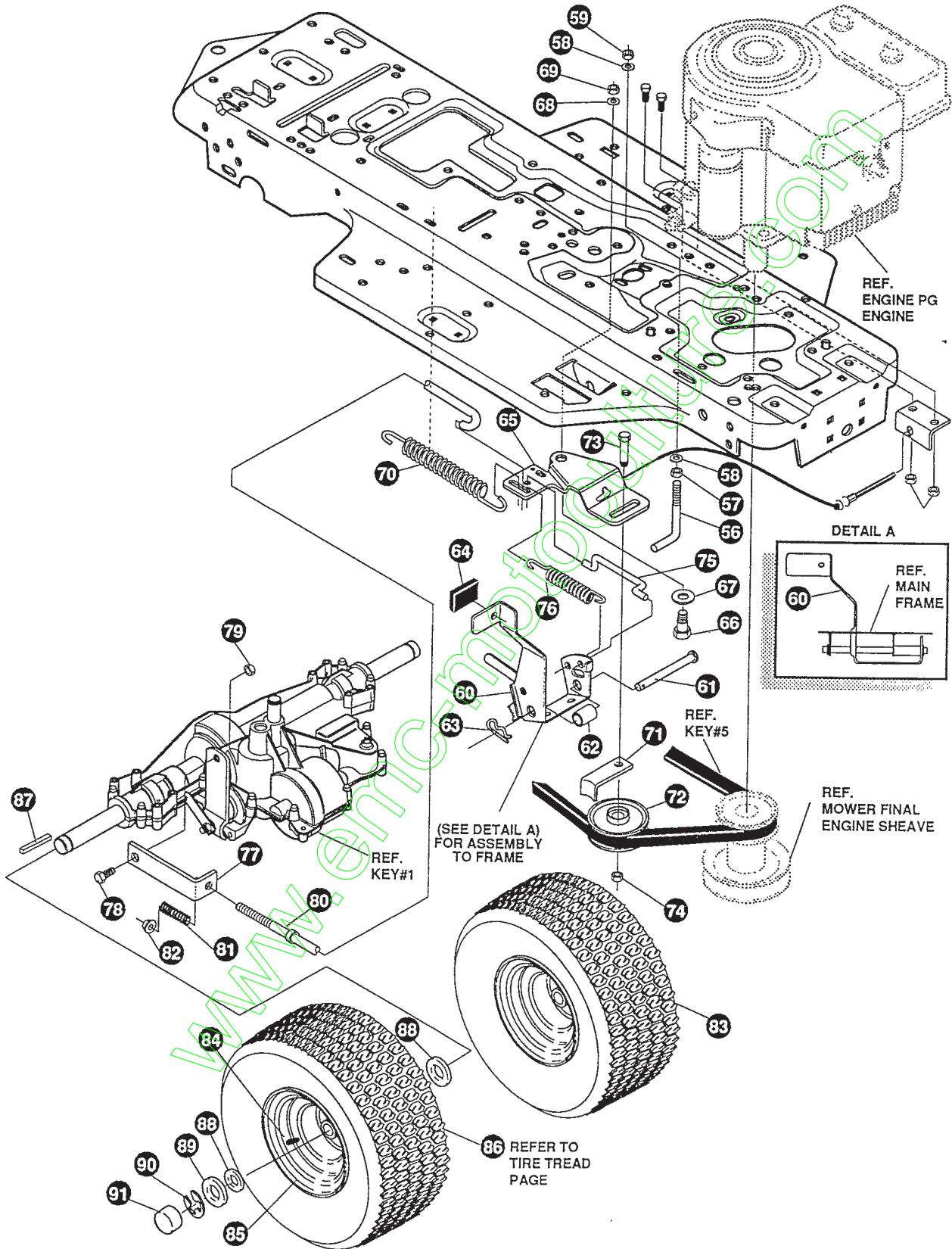

NOTE: ALWAYS USE ORIGINAL EQUIPMENT PARTS. Use of service/replacement parts other than original equipment parts may void your warranty.

ALL UNNUMBERED ITEMS ARE INTERCHANGEABLE WITH OPPOSITE SIDE

328927D

39" LAWN TRACTOR MODEL D3554-180

KEY#	PART#	DESCRIPTION	QTY.
56.	49896	BELT GUIDE	1
57.	271184	NUT, 5/16-18 HEXKEPS	1
58.	120393	WASHER, FLAT .344X.69X.065	2
59.	1498	NUT, 5/16-18 REGHEXCTRLK	1
60.	302603	SF ASSY,BRAKE PEDAL S.F.	1
61.	319676	PIN, CLEVIS .500DX4.87LG	1
62.	302601	SPACER, SLEV .53 X .62X1.406	1
63.	56180	PIN, HAIR .091 DIAX1.62LG	1
64.	48761	PAD,CLUTCH/BRAKE PEDAL	1
65.	321969	MF IDLER ARM BRKT TRACTION SF	1
66.	41890	BOLT, .625X .218 HSH 5/16-18	1
67.	4107	WASHER, FLAT .635X1.31X.07	1
68.	45602	WASHER, FLAT .333X .87X.119	1
69.	1498	NUT, 5/16-18 REGHEXCTRLK	1
70.	327867	SPRING,3/4 ODX7.75X.091 TENSIO	1
71.	39659	MF RETAINER,BELT	1
72.	35374	PULLEY, IDLER V4L 3.06X .62	1
73.	45892	BOLT, 3/8-16X1.50 CARR	1
74.	1499	NUT, 3/8-16 REGHXCTRLK	1
75.	43980	ROD, .268 DIA CLUTCH	1
76.	50562	SPRING,3/8ODX1.625X.055 TENSIO	1
77.	322613-954	BRACKET, TRACTION BRAKE S/F	1
78.	46824	BOLT, .500X .188 HSH 5/16-18	1
79.	1498	NUT, 5/16-18 REGHEXCTRLK	1
80.	322614-954	ROD, BRAKE 915 T/A SF	1
81.	53820	SPRING, CLUTCH .625 OD	1
82.	50352	NUT, 1/4-20 WDFLLK TOPLOCK	1
83.	*	TIRE & RIM,20X8.00-8	2
84.	24167	VALVE STEM	1
85.	326362	WHEEL, 20X8.00	1
86.		REFER TO TIRE READ PAGE	1
87.	52928	KEY, SQUARE .187SQX2.25LG	1
88.	642	WASHER, FLAT .755X1.31X.075	4
89.	42815	WASHER, FLAT .755X1.53X.07	2
90.	36625	RING, RETEX .57X.05TRU5133-75	2
91.	40394	HUB CAP, 1.500ID X 7/8LG	2

* ORDER INDIVIDUAL PARTS.

57165 Fols

www.enr.com

39" LAWN TRACTOR MODEL D3554-180

ENGINE & CONTROL ASSEMBLY

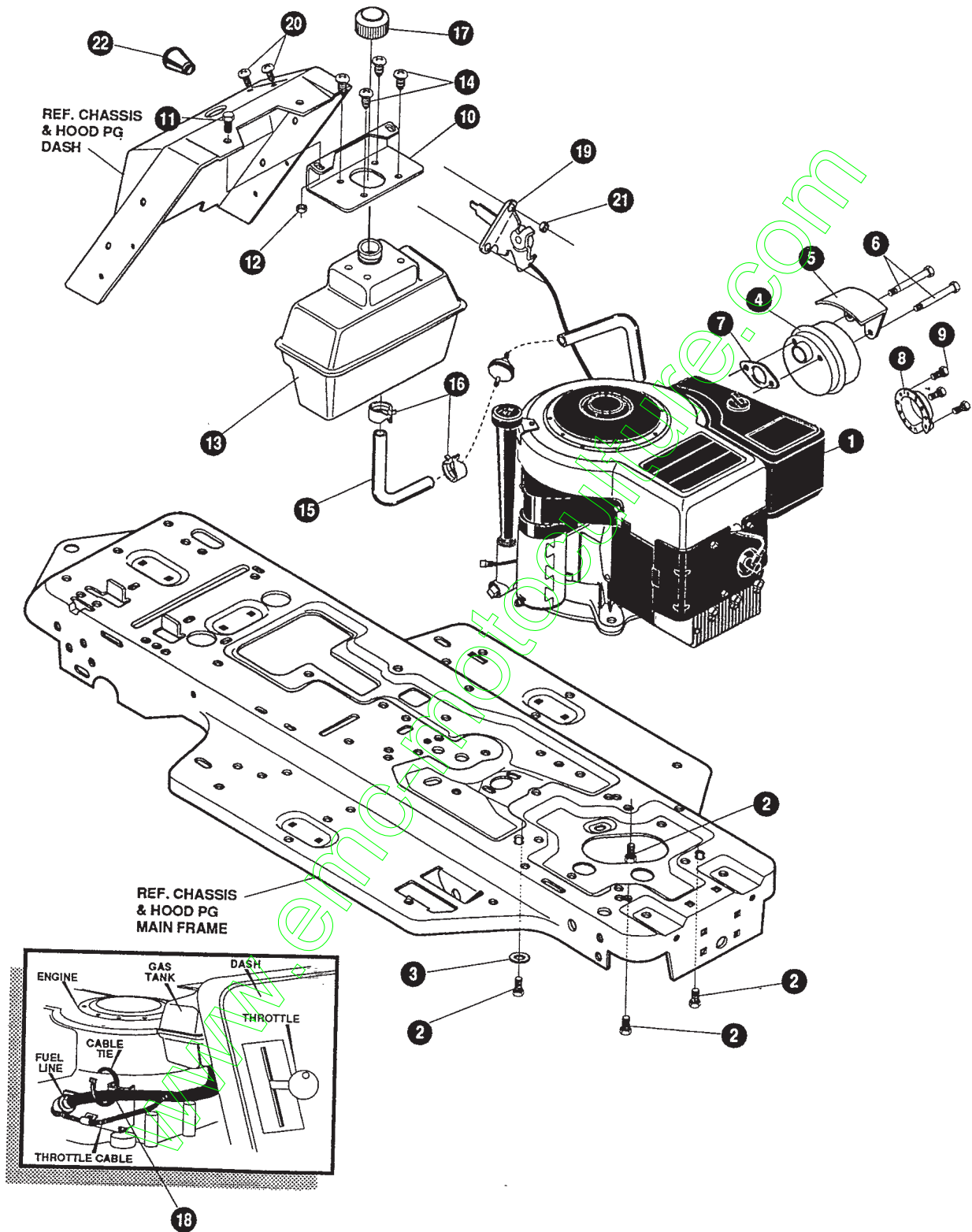

NOTE: ALWAYS USE ORIGINAL EQUIPMENT PARTS. Use of service/replacement parts other than original equipment parts may void your warranty.

ALL UNNUMBERED ITEMS ARE INTERCHANGEABLE WITH OPPOSITE SIDE

327911A

39" LAWN TRACTOR MODEL D3554-180

KEY#	PART#	DESCRIPTION	QTY.
1	ENGINE	12 HP B&S IC (SEE ENGINE MANUAL)	1
2	• 50947	SCREW, 3/8-16X1.25 WAHTAP	4
3	• 138489	WASHER, EXLK .384X.69X.04	1
4	57908	MUFFLER-LO TONE NELSON EXPORT	1
5	54767	SHIELD, HEAT, FOR ROUND MUFFLER	1
6	173063	SCREW, 5/16-18X3.50 HHC	2
7	46708	GASKET, MUFFLER	1
8	323423	DEFLECTOR MUFFLER	1
9	35287	SCREW, #8-32X.38 HHWATAP GR 2	1
10	302814-853	BRACKET, GAS TANK	1
11	• 55686	SCREW, 1/4-20X .63 SLTRMA	2
12	• 51335	NUT, 1/4-20 WDFLLK	2
13	314989	TANK, FUEL 1 GAL	1
14	• 49050	SCREW, 1/4-10X .75PHPNTAP	4
15	41007	GAS LINE .25ID	15"
16	47345	CLAMP, FUEL LINE	2
17	46704	GAS CAP 1-1/2-7	1
18	57444	TIE, CABLE	1
19	320031	THROTTLE, CONTROL	1
20	35291	SCREW, #10-24 X .50	2
21	271166	NUT, #10-24 HEX REPS	2
22	50607	KNOB, ROUND THROTTLE	1

• INDICATES STANDARD HARDWARE ITEMS.

39" LAWN TRACTOR MODEL D3554-180

PRE-PAINTED DECK

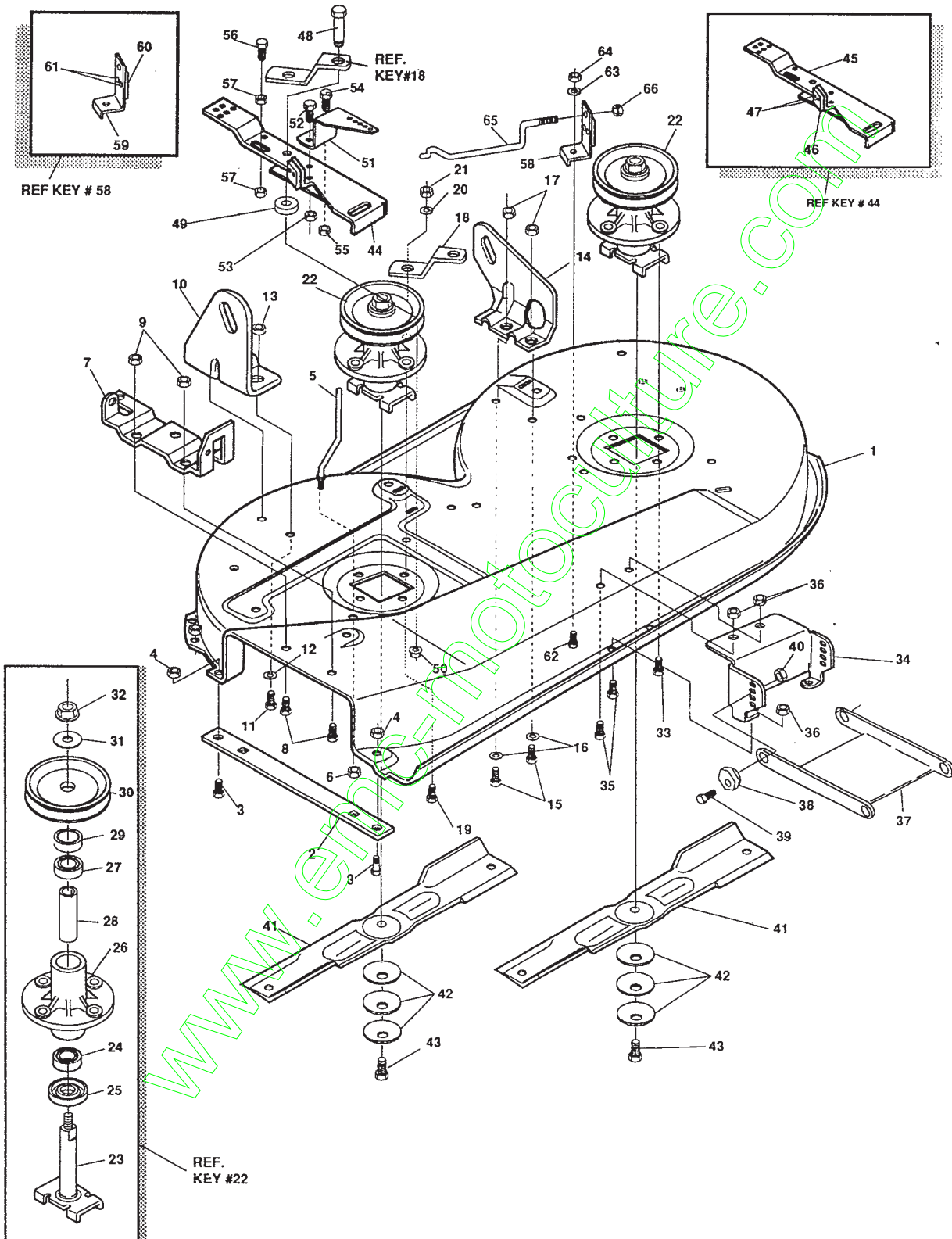

NOTE: ALWAYS USE ORIGINAL EQUIPMENT PARTS. Use of service/replacement parts other than original equipment parts may void your warranty.

ALL UNNUMBERED ITEMS ARE INTERCHANGEABLE WITH OPPOSITE SIDE

326046C

39" LAWN TRACTOR MODEL D3554-180

KEY#	PART#	DESCRIPTION	QTY.
1	325106	DECK,39"SD MOWER	1
2	326295-853	BAR, SKID-MULCH	1
3	126216	BOLT, 5/16-18X .75 CARR	2
4	◇271184	NUT, 5/16-18 HEXKEPS	2
5	57318	GUIDE, BELT 5/16-18 THD	1
6	◇1498	NUT, 5/16-18 REGHEXCTRLK	1
7	313928	BRACKET, CHUTE	1
8	◇180073	SCREW, 5/16-18X .50 HHC	2
9	◇1498	NUT, 5/16-18 REGHEXCTRLK	2
10	313929	LIFT BRACKET, REAR,RH	1
11	◇180077	SCREW, 5/16-18X .75 HHC	2
12	120393	WASHER, FLAT .344X .69X.065	2
13	◇1498	NUT, 5/16-18 REGHEXCTRLK	2
14	310667	BRACKET,DECK LIFTREAR LH	1
15	◇180077	SCREW, 5/16-18X .75 HHC	2
16	120393	WASHER, FLAT .344X .69X.065	2
17	◇1498	NUT, 5/16-18 REGHEXCTRLK	2
18	315302-853	BRACKET, IDLER SUPPORT	1
19	◇300345	SCREW, 5/16-18X1.38 WATAP	1
20	120393	WASHER, FLAT .344X .69X.065	1
21	◇1498	NUT, 5/16-18 REGHEXCTRLK	1
22	56424-853	QUILL ASSY, 36/39/40/43	2
23	56425	SHAFT/SADDLE 36"	1
24	49562	BRNG, BALL	1
25	50616	DUST SHIELD	1
26	55547	QUILL CASTING	1
27	49562	BRNG, BALL	1
28	50818	SPACER,3.797LGX.669IDX.88OD	1
29	51449	SPACER, 438LGX.932ODX.672ID-PM	1
30	313898	PULLEY,26/36" QUILL	1
31	56365	SPECIAL WASHER	1
32	◇1282	NUT, 7/16-20 WDFLLK	1
33	◇50634	SCREW, 5/16-18X .88 WAHHTAP	8
34	312526	LIFT SUPPORT FRONT DECK	1
35	◇180075	SCREW, 5/16-18X .63 HHC	4
36	◇1498	NUT, 5/16-18 REGHEXCTRLK	4
37	58305-853	LINK BRACKET,DECK FR	1
38	58247	ADJUSTING NUT	2
39	◇122017	SCREW, 5/16-18X1.00 HHC	2
40	◇1498	NUT, 5/16-18 REGHEXCTRLK	2
41	309069	BLADE, 19.69 LO-LIFT	2
42	2483	WASHER,.39IDX1.25DX.07 BELLVIL	6
43	◇39573	SCREW, 3/8-24X1.00 NYLHHC	2
44	320565-853	IDLER ARM ASSY.	1
45	300490-853	IDLER ARM	1
46	306973	BRAKE PAD	1
47	41601	RIVET,OVSET 187 DIA X .50 LG ST	2
48	300180	BOLT,.50 X .188 HHSH3/8-16	1
49	996416	WASHER,FLAT .391 X 1.— X .125	1
50	45171	NUT,5/16-18 X .75 HHC WHIZ-LOCK	1
51	326249-853	BRACKET EXTENSION IDLER	1
52	180077	SCREW,5/16-18 X .75 HHC	1
53	1498	NUT, 5/16-18 REGHEXCTRLK	1
54	120854	SCREW, 1/4-20X.63 HHC-GR2	1
55	1502	NUT, 1/4-20 REGHXCTRLK	1
56	121954	SCREW,1/4-20X2.00 HHC	1
57	271172	NUT,1/4-20 REGHEXKEPS	2
58	303247-853	ASSY BLADE BRAKE	1
59	303246-853	BRAKE ARM	1
60	306973	BRAKE PAD	1
61	135624	RIVET,TRSET .185 DIA X.41	2
62	180075	SCREW,5/16-18X.63 HHC	1
63	120393	WASHER,FLAT .344 X .69 X .65	1
64	1498	NUT, 5/16-18 REGHEXCTRLK	1
65	300316	ROD,BRAKE	1
66	1502	NUT,1/4-20 REGHEXCTRLK	1

39" LAWN TRACTOR MODEL D3554-180

FINAL DECK ASSEMBLY

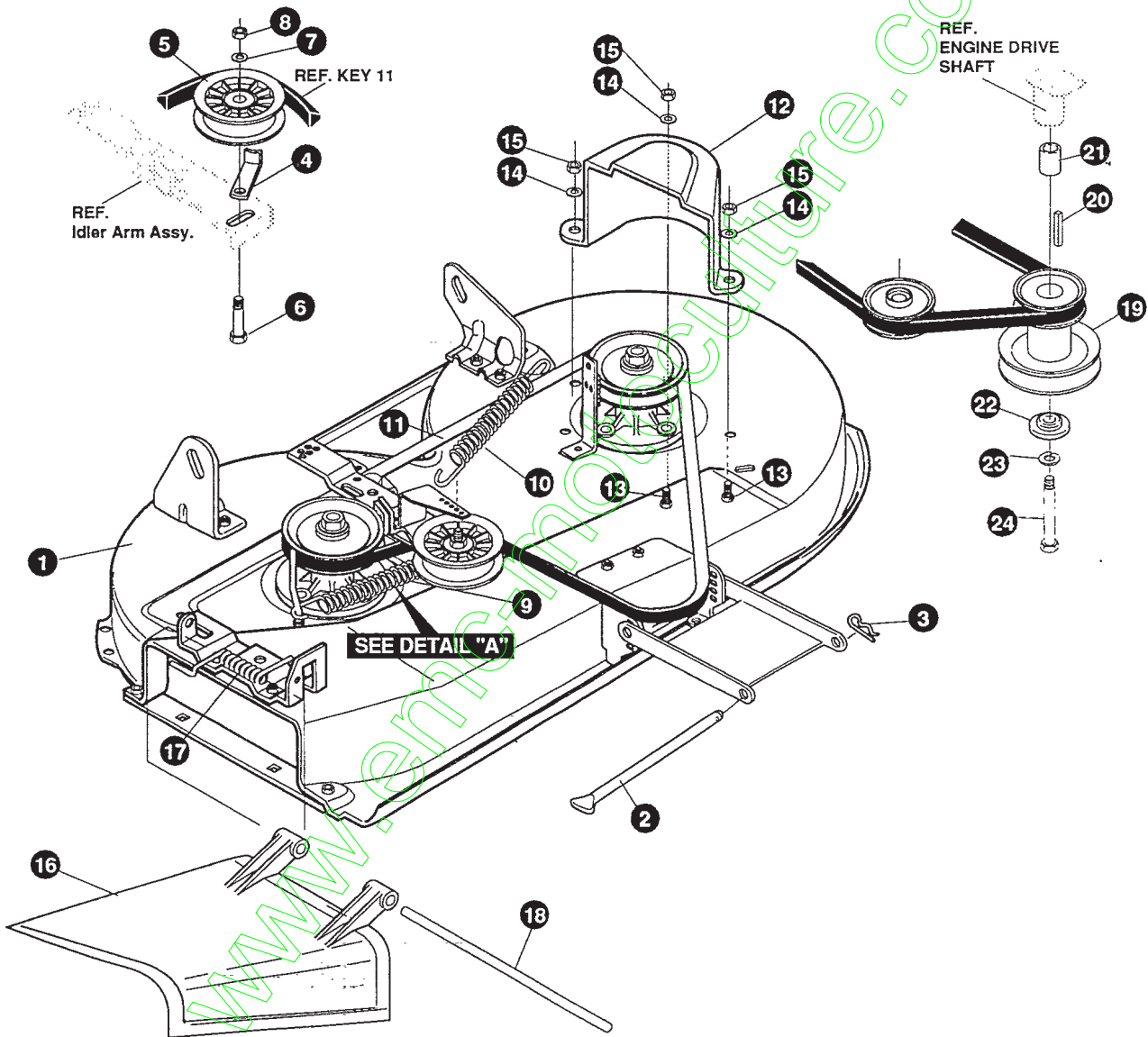
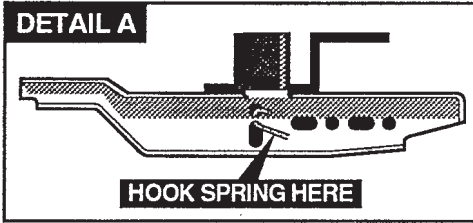

NOTE: ALWAYS USE ORIGINAL EQUIPMENT PARTS. Use of service/replacement parts other than original equipment parts may void your warranty.

ALL UNNUMBERED ITEMS ARE INTERCHANGEABLE WITH OPPOSITE SIDE

326048B

39" LAWN TRACTOR MODEL D3554-180

KEY#	PART#	DESCRIPTION	QTY.
1	^	ASSY DECK 39SD 2-DECKWH	1
2	58306	ROD, DECK HITCH	1
3	8260	PIN, HAIR .091 DIA X 1.66	1
4	1346	BELT RETAINER 2.55 OD <i>300844</i>	1
5	310326	PULLEY, IDLER BFF 4.00	1
6	57325	BOLT, 3/8-16 X 2.00 CARR	1
7	120382	WASHER, REGSPTLK .393 X .68 X .10	1
8	◇ 120377	NUT, 3/8-16 REGHX <i>1499</i>	1
9	322064	SPRING .071 X .62 X 4.37	1
10	326256	SPRING, TENSION	1
11	300680	BELT, V 5L 77.75	1
12	328257	GUARD, BELT LH	1
13	180075	SCREW, 5/16-18 X .63 HHC	3
14	120393	WASHER, FLAT .344 X .69 X .065	3
15	◇ 1498	NUT, 5/16-18 REGHEX CTRLK	3
16	57818	CHUTE-36SD, 39SD	1
17	314975	SPRING, TORSION	1
18	57317	PIVOT ROD, CHUTE	1
19	310250	PULLEY ENGINE	1
20	303151	KEY SQUARE .249 X 4.50	1
21	304246	SPACER SLEV 1.01 X 1.48	1
22	56431	WASHER .980 X 1.38 X 4.37 PILOT	1
23	120383	WASHER, REGSPTLK .459 X .78 X .12	1
24	433146	SCREW, 7/16-20 X 4.25	1

◇ INDICATES STANDARD HARDWARE ITEMS
 ^ ORDER INDIVIDUAL PARTS.

www.emc-motoculture.com

39" LAWN TRACTOR MODEL D3554-180

ELECTRICAL ASSEMBLY

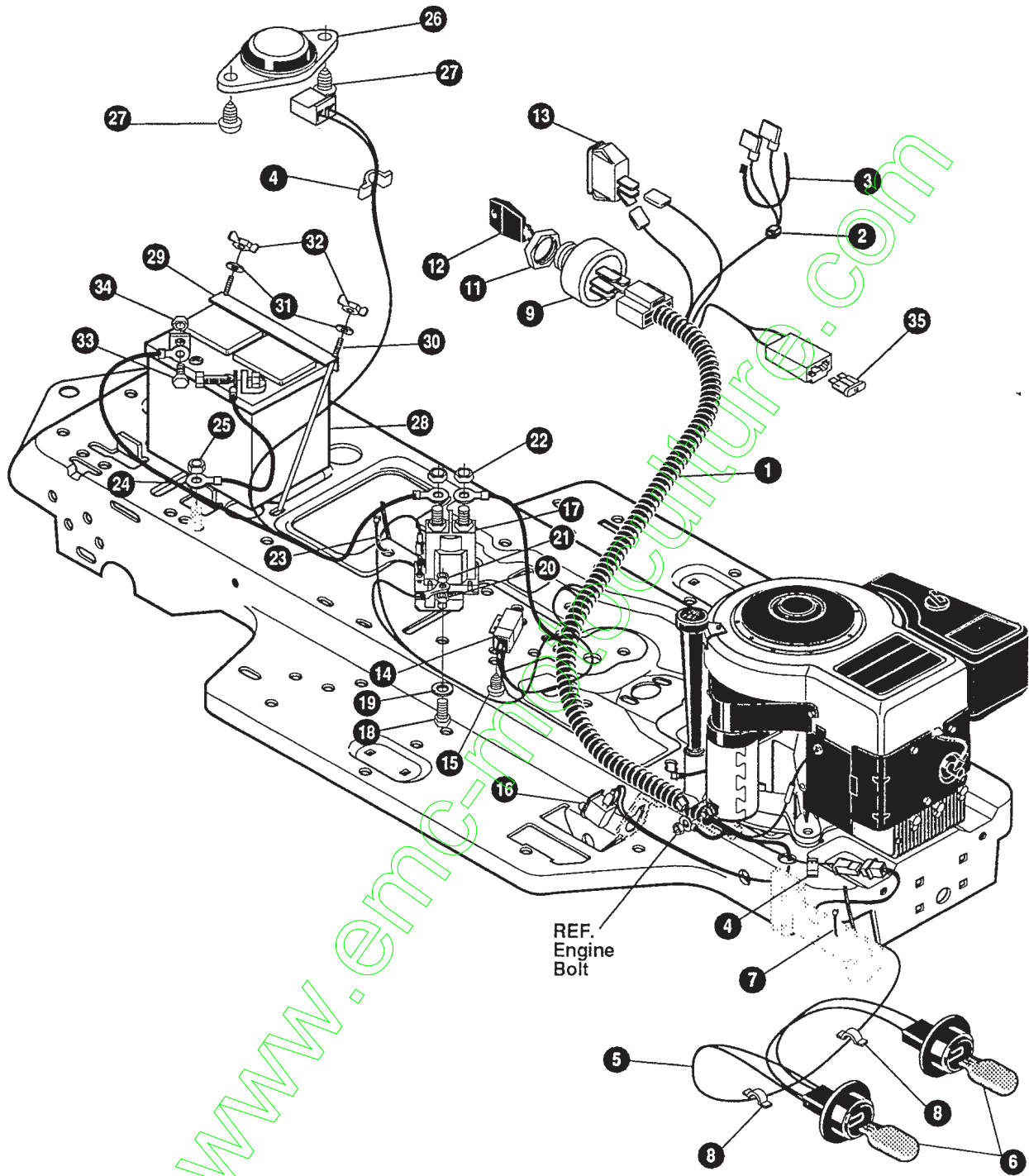

NOTE: ALWAYS USE ORIGINAL EQUIPMENT PARTS. Use of service/replacement parts other than original equipment parts may void your warranty.

ALL UNNUMBERED ITEMS ARE INTERCHANGEABLE WITH OPPOSITE SIDE

326872A

39" LAWN TRACTOR MODEL D3554-180

KEY#	PART#	DESCRIPTION	QTY.
1.	325084	WIRE HARNESS SF 12B&S IC W/AMM	1
2.	322298	SPLICER	1
3.	57444	TIE,CABLE	1
4.	41482	PRESS CLIP,1.380LG .255ID	2
5.	303064	ASSY,LIGHT WIRE-1/4 TURN	1
6.	316823	BULB, HEADLAMP	2
7.	57444	TIE, CABLE BLACK NYLON 5.62L	1
8.	41482	PRESS CLIP,1.380LG .255ID	2
9.	327355	SWITCH-IGN.(AFTER FIRE) 3 POSN	1
11.	327352	NUT, 5/8-8 ACME DELTA	1
12.	327349	KEY, IGNITION SWITCH,STEEL	1
13.	300334	LIGHT SWITCH ON/OFF PANEL MNT	1
14.	57476	SWITCH,SCR MNT DP NC NO BLK	2
15.	• 57220	SCREW, #12 X .50 PHPNHTAP BLK	2
16.	326653	SWITCH,SNAPMNT NO .055/.116BLK	1
17.	53716	SOLENOID	1
18.	• 187745	SCREW, 1/4-20X .75 HXSEMMA	2
19.	1084	WASHER, FLAT .281X1.00X.063PL	1
20.	• 1502	NUT, 1/4-20 REGHEXCTRLK	2
21.	• 271172	NUT, 1/4-20 REGHEXKEPS	1
22.	• 271187	NUT, 5/16-24 HKEPS	2
23.	57444	TIE, CABLE BLACK NYLON 5.62L	1
24.	55511	WIRE, GROUND, 12.5"	1
25.	• 271184	NUT, 5/16-18 HEXKEPS	1
26.	57547	SWITCH, SEAT	1
27.	• 160505	SCREW, 1/4-20X .38PHPNHMA	2
28.	302257	BATTERY, YUASA 12V 5-PLATE	1
29.	324719	BATTERY BRACKET	1
30.	40234	BATTERY ROD	2
31.	120392	WASHER, FLAT .281X .63X.065	2
32.	• 325232	WINGNUT, 1/4-20 NYLON	2
33.	• 120854	SCREW, 1/4-20X .63 HHC	2
34.	• 271172	NUT, 1/4-20 REGHEXKEPS	2
35.	• 302031	FUSE, 15 AMP SPADE TYPE	1

- INDICATES STANDARD HARDWARE ITEMS
- Spade type fuse included with the wire harness.

SCHEMATIC DRAWING

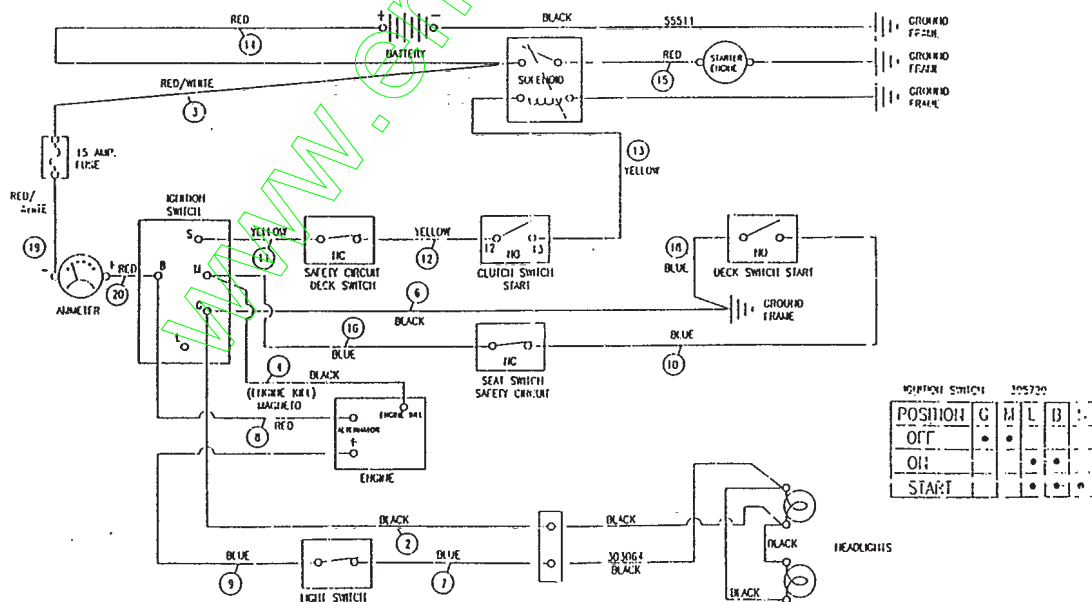

39" LAWN TRACTOR MODEL D3554-180

DECALS (DECORATIVE)

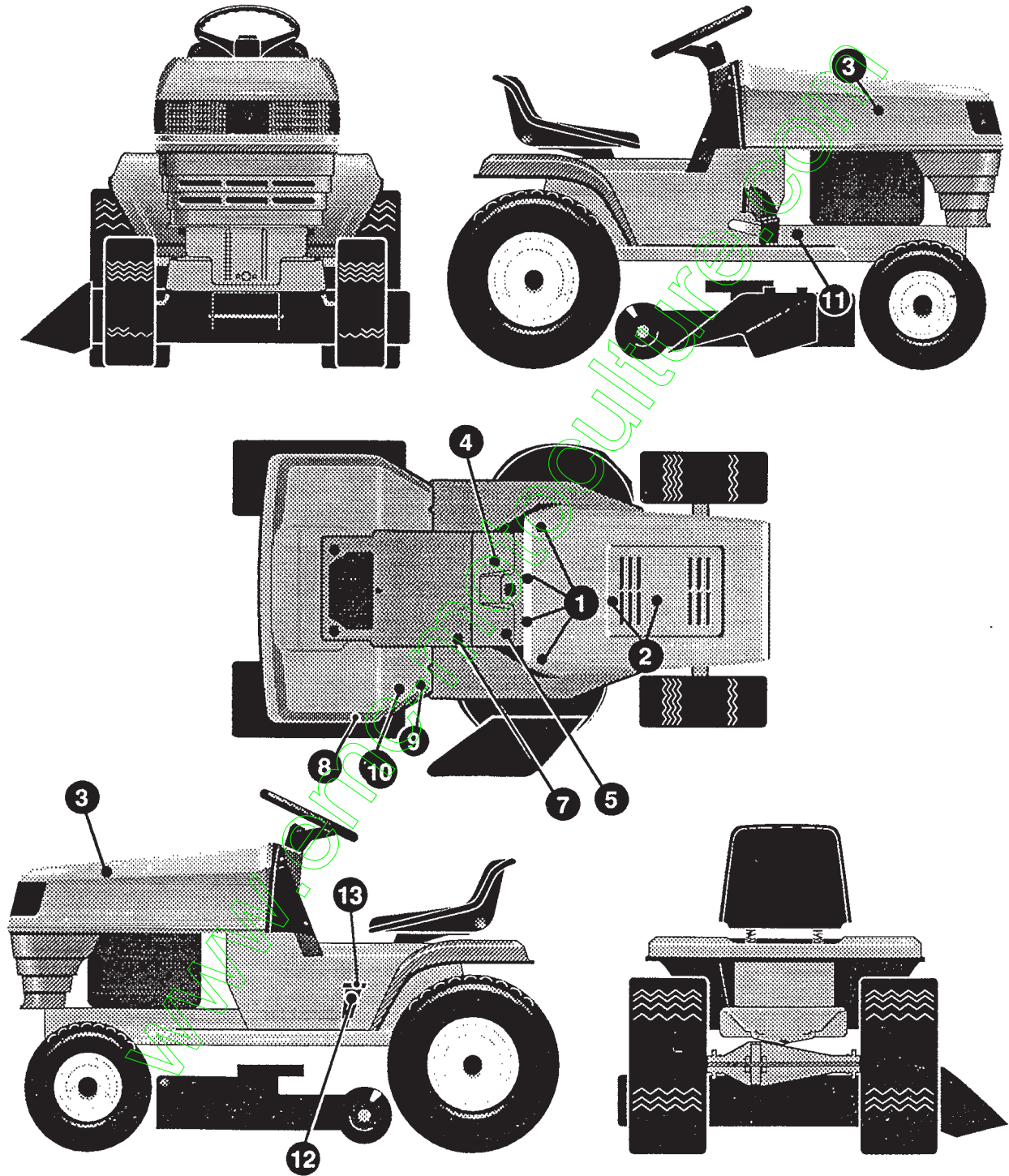

39" LAWN TRACTOR MODEL D3554-180

KEY#	PART#	DESCRIPTION	QTY.
1.	327955	DECAL, HOOD SIDE LH TEXAS	1
2.	327956	DECAL, HOOD SIDE RH TEXAS	1
3.	327953	DECAL, CONSOLE SIDE L TEXAS SF	1
4.	327954	DECAL, CONSOLE SIDE L TEXAS SF	1
5.		REFERENCE ONLY	1
5.	307732	DECAL LENS CENTER SMOKED	1

www.emc-motoculture.com

39" LAWN TRACTOR MODEL D3554-180

DECALS (INSTRUCTIONAL)

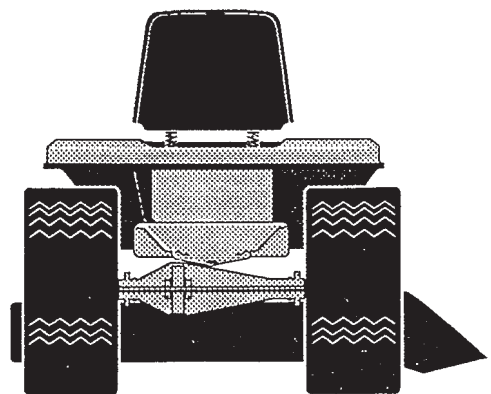
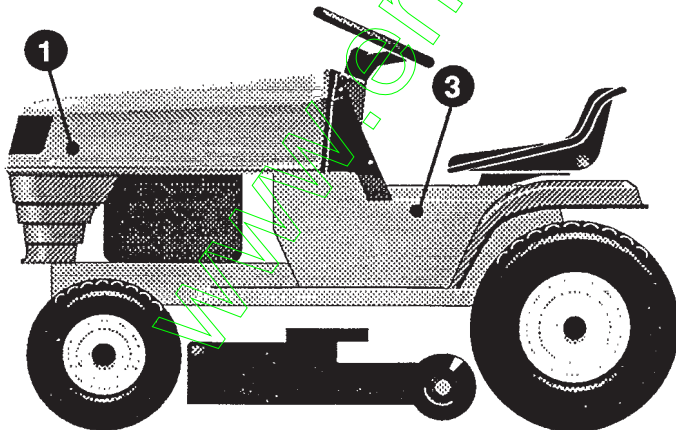
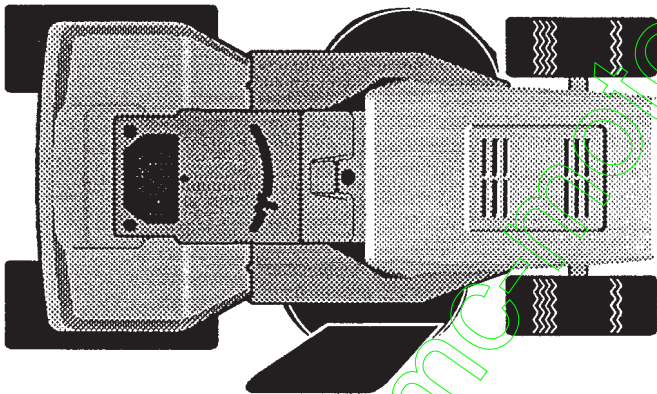
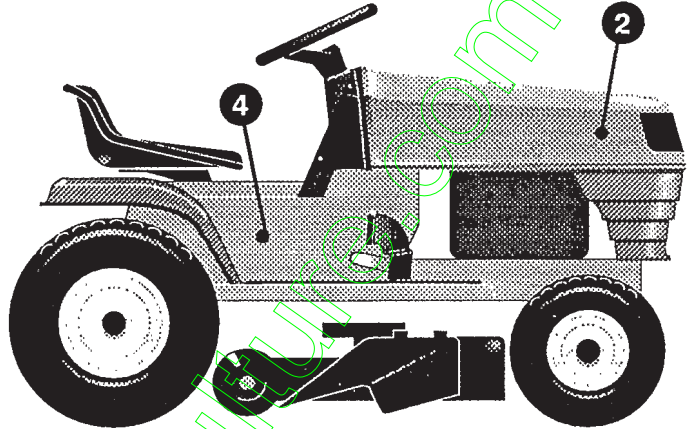
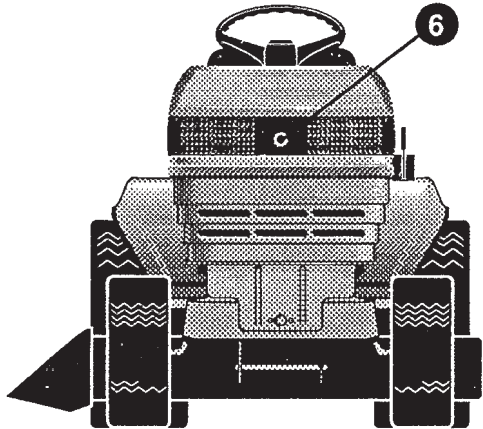

39" LAWN TRACTOR MODEL D3554-180

KEY#	PART#	DESCRIPTION	QTY.
1.	318197	PAD,ADHESIVE 1.00X1.50X.12	4
2.	305602	FOAM,HOOD 4X15	2
3.	305603	PAD, 18 X 6 FOAM HOOD	2
4.	320717	DECAL,DASH PLAIN EXPORT	1
5.	327610	DECAL,PTO ENGAGEMENT, ISO EXP	1
6.		REFERENCE ONLY	1
7.	307376	DECAL,INSTR.,CONSOLE DANISH	1
8.	322170	DECAL,FENDER 5 SPEED SOG	1
9.	305770	DECAL,CAUTION TRIANGLE EUROPE	1
10.	307377	DECAL,WARNING DANISH	1
11.	68903	DECAL,BRAKE/CLUTCH ISO	1
12.	320892	DECAL, INSTR. PEDAL LIFT	1
13.	327146	DECAL, PEDAL LIFT INDICATOR	1

www.emc-motoculture.com

39" LAWN TRACTOR MODEL D3554-180

CUSTOMER ASSEMBLY

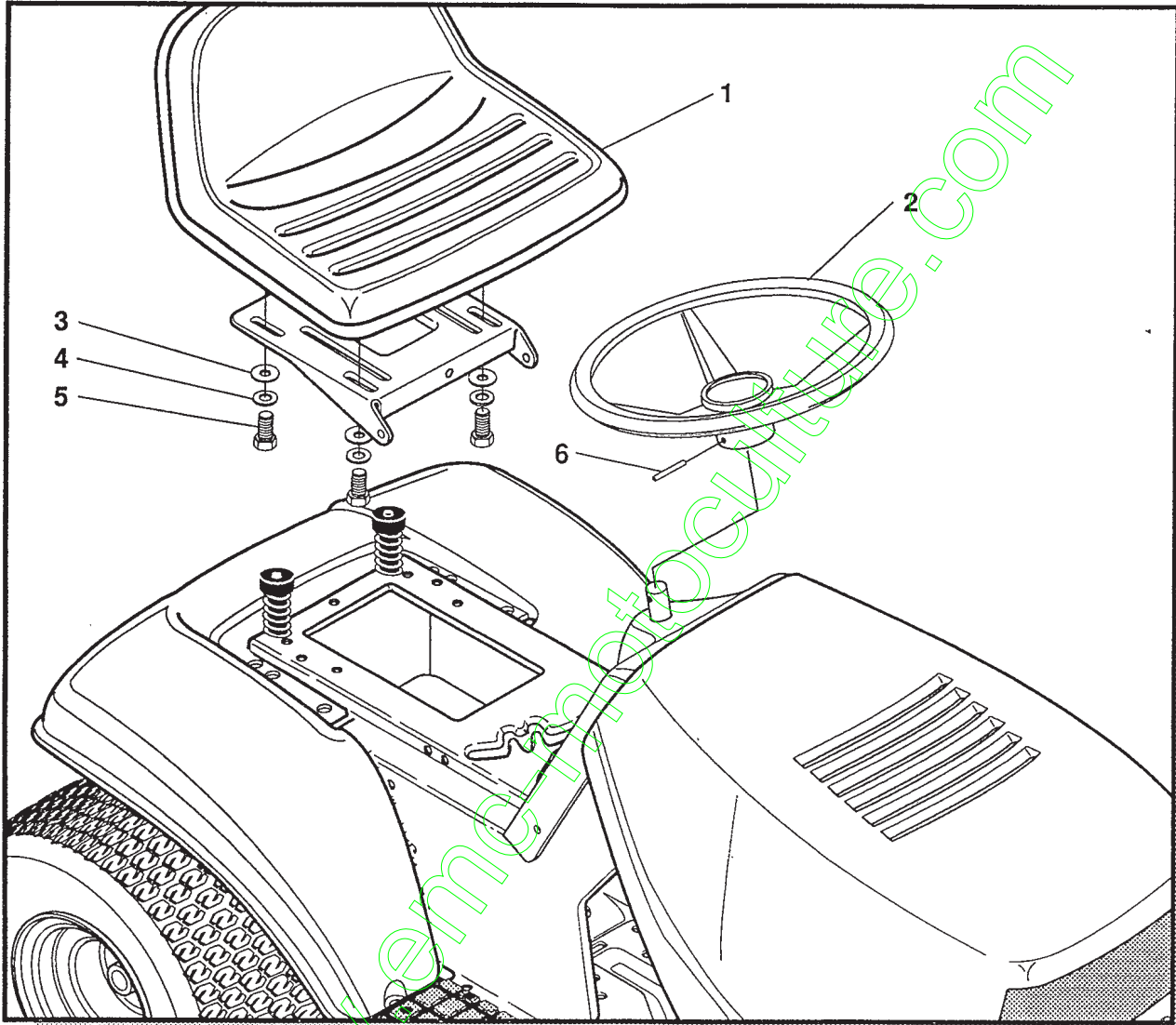

CUSTOMER ASSEMBLY VIEW

315984 PARTS BAG ASSY QTY1

KEY#	PART#	DESCRIPTION	QTY.
1	57455	SEAT M-450	1
2	301251	STEERING WHEEL	1
3	120393	WASHER, FLAT .344X.69X.065	4
4	120638	WASHER, HV SPLTLK .328X.60X.109	4
5	122007	SCREW, 5/16-18X.75 HHC	4
6	456378	ROLL PIN .250DIA X 2.0LG	1

316164B

39" LAWN TRACTOR MODEL D3554-180

TREAD PATTERNS

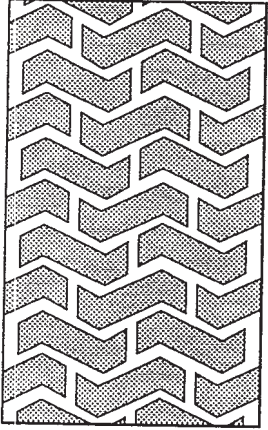

"A"

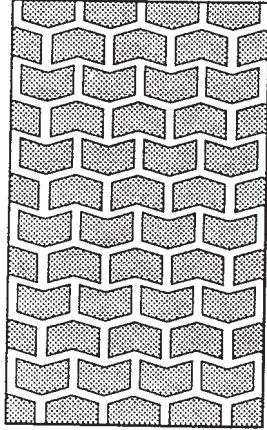

"B"

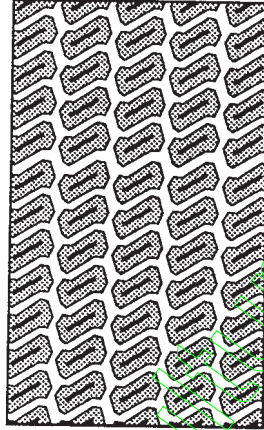

"C"

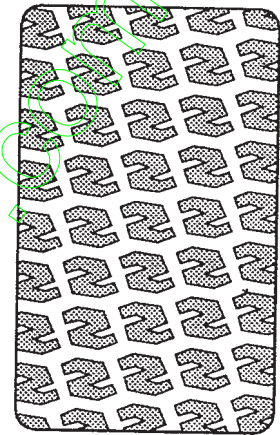

"D"

TIRE SIZE

TIRE SIZE	"A"	"B"	"C"	"D"
11 X 4.00 - 5	42295	319679		
13 X 5.00 - 6	41060	319680		
15 X 6.00 - 6	39830	316702	301140	313952
16 X 6.50 - 8	41081	319682		314539
18 X 8.50 - 8	319683	317400		
18 X 9.50 - 8	41106	316701		313950
20 X 8.00 - 8	319685	319684	57164	314584
20 X 10.00 - 8	58276	319686		313654
20 X 10.00 - 10	55893	319687		
23 X 9.50 - 12	53655	319690	319689	314370

ACCESSORIES

Contact the dealer where your tractor was purchased for the available accessories. If you are unable to contact the dealer, write to the address on the front cover of this manual.

Rear Engine Rider

Model	Description
5708-16	Bagger - Fits 32" Side Discharge
5708-17	Bagger - Fits 36" Side Discharge & 30" Top Discharge
5709-02	Front Weight Box - holds 35 lbs.
5648-16	Lawn Sweeper w/dump Release
5714-00	Mulching Kit - 30" Top Discharge

Lawn Tractor

Model	Description
5708-22	Bagger - Fits 30" Side Discharge
5708-13	Bagger - Fits 36", 38", 39" & 45" Side Discharge
5705-04	36" Two-Stage Snowblower - Fits 36", 38", 39", & 45" Side Discharge
5661-06	42" Snowblade - Fits 36", 38", 39", & 45"
5592-00	Tire Chains - 18" x 6.50"
5585-00	Tire Chains - 18" x 9.50" & 20" x 8"
5672-01	Wheel Weights - Front - 1 pr. w/mtg. hdw. - Fits 15" tires
5673-02	Wheel Weights - Rear - 1 pr. w/mtg. hdw. - Fits 18" & 20" tires
5709-03	Front Weights - Fits 30" & 32" Side Discharge
5648-16	Lawn Sweeper w/dump Release
5714-00	Mulching Kit - 30" Top Discharge

Garden Tractor - Light Ground Engaging

Model	Description
5708-13	Bagger - Fits 36", 38", 39", & 45" Side Discharge
5705-04	36" Two - Stage Snowblower - Fits 36", 38", 39", & 45"
5661-06	42" Snowblade - Fits 36", 38", 39", & 45"
5672-01	Wheel Weights - Front 1 pr. w/mtg. hdw. - Fits 15" tires
5673-02	Wheel Weights - Rear - 1 pr. w/mtg. hdw. - Fits 18" & 20" tires
5648-16	Lawn Sweeper w/dump Release
5667-02	Sleeve Hitch - w/lift bar - Fits 45"
5668-01	Adaptor (sleeve hitch) for use w/23" tires
5706-00	Tire Chains - 20" x 10"
5671-00	Tire Chains - 23" x 9.50"
5672-02	Wheel Weights - Front - 1 pr. w/mtg. hdw. Fits 16" tires
5673-00	Wheel Weights - Rear - 1 pr. w/mtg. hdw. Fits 23" tires
5674-01*	10" One Bottom Moldboard Plow
5675-01*	Cultivator - 7 row - Adj. 6" - 42" width
5676-01*	Disc Harrow - 8" & 11" disc - Adj. width & disc angle
5677-02*	Tiller - 5 H.P. Self-Powered - 28" width

Four Wheel Steer

Model	Description
5708-14	Bagger - Fits 40" & 46" Side Discharge
5705-05	42" One-Stage Snowblower - Fits 40" & 46"
5661-07	48" Snowblade - Fits 40" & 46"
5709-04	Rear Weight Box for 40" & 46"
5648-16	Lawn Sweeper w/dump Release
5706-00	Tire Chains 20" x 10"
5671-00	Tire Chains 23" x 9.50"
5672-02	Wheel Weights - Front - 1 pr. w/mtg. hdw. Fits 16" tires
5673-00	Wheel Weights - Rear - 1 pr. w/mtg. hdw. Fits 23" tires
5672-01	Wheel Weights - Front - 1 pr. w/mtg. hdw. Fits 15" tires
5673-02	Wheel Weights - Rear - 1 pr. w/mtg. hdw. Fits 18" & 20" tires

Two Wheel Steer Garden Tractor

Model	Description
5667-04	Sleeve Hitch - w/lift bar Fits 46"
5674-01*	10" One Bottom Moldboard Plow
5675-01*	Cultivator - 7 row - Adj. 6" - 42" width
5676-01*	Disc Harrow 8" & 11" Disc. Adj. width & disc angle
5677-02*	Tiller 5 H.P. Self-Powered - 28" width
5648-16	Lawn Sweeper w/dump Release

*Requires a sleeve hitch