

TRACTEUR TONDEUSE 40" MODELE D3560-311

ENSEMBLE CHASSIS & CAPOT (AVANT)

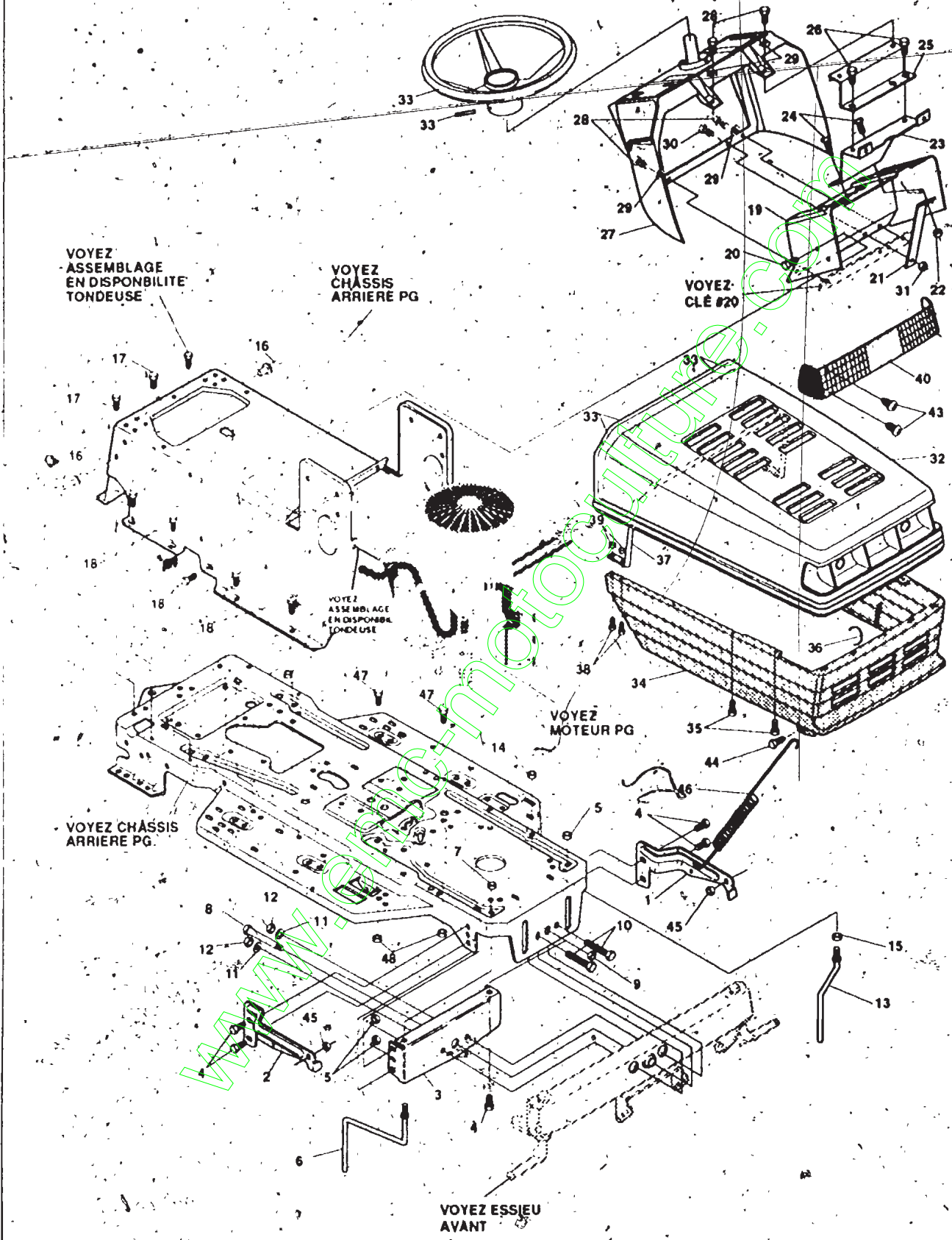

UTILISEZ DES PIÈCES D'ORIGINE POUR CONSERVER L'APPLICATION DE LA GARANTIE.

TOUTES LES PIÈCES NON REFEREES SONT INTERCHANGEABLES AVEC LEURS OPPOSEES.

325877B

TRACTEUR TONDEUSE 40" MODELE D3560-311

KEY#	PART#	DESCRIPTION	QTY
1	326569-853	BRACKET,GRILLE LH	1
2	326568-853	BRACKET,GRILLE RH	1
3	313541-853	BRACKET, FRONT AXLE	1
4	56030	SCREW, 5/16-18X.75WDFLLK	5
5	55273	NUT, 5/16-18 HXWDFLLK	5
6	300440	GUIDE, BELT, RIDER	1
7	1498	NUT, 5/16-18 REGHEXCTRLK	1
8	308207	BOLT, .625X2.180 HSSH 1/2-13	1
9	309008	NUT, 1/2-13 REGHCTRLK	1
10	122207	SCREW, 3/8-16X3.00 HHC	2
11	2483	WASHER, 39IDX1.25DX.07 BELLVIL	2
12	1499	NUT, 3/8-16 REGHCTRLK	2
13	300635	GUIDE, SHORT BELT RIDER 15"WH	1
14	124824	NUT, 5/16-18 HEXJAM	1
15	271190	NUT, 3/8-16 HEXKEPS	1
16	46763	RIVET, POP .187DIA X .450LG	3
17	35497	SCREW, 5/16-18X .50 WAHTAP	2
18	995346	SCREW, 1/4-20X .50 WAHTAP	10
19	58312-853	SUPPORT, DASH	1
20	300303	SCREW, 25X 75X 75HHWAPLASTITE	2
21	300201-853	BRACE, DASH SUPT LOWER	1
22	1502	NUT, 1/4-20 REGHEXCTRLK	1
23	302530-853	BRKT, GAS TANK	1
24	995346	SCREW, 1/4-20X .50 WAHTAP	2
25	300264-853	BRACE, DASH SUPT UPPER	1
26	995346	SCREW, 1/4-20X .50 WAHTAP	2
27	305429	DASH,GP. W/O GRAPHIC,SUS	1
28	995346	SCREW, 1/4-20X .50 WAHTAP	4
29	316868	WASHER, SHOULDER NYLON .255X 46	4
30	44811	SCREW, 1/4-20X .75 HXWATAP	1
31	1502	NUT, 1/4-20 REGHEXCTRLK	1
32	307033	HOOD	1
33	318197	PAD, ADHESIVE 1 00 X	4
34	303037	GRILL, LWR GPWR	1
35	300302	SCREW, #10 X .50 HHTAPPST	4
36	310203	CLIP, HOG RING C-SHAPED	1
37	301425	BRACE, HOOD SUPPORT	1
38	301542	SCREW, 10-2451.00HWATAPBLKPHOS	4
39	271166	NUT, #10-24 HEXKEPS	4
40	302333	LENS, SMOKED W/TAB	1
43	57796	SCREW, #6 X .50 PLASTITE	4
44	56676	BOLT, .375X .580 HSSH 5/16-18	2
45	1498	NUT, 5/16-18 REGHEXCTRLK	2
46	57478	SPRING, HOOD LATCH	2
47	180079	SCREW 5/16-18X 1.00 HHC	2
48	1498	NUT, 5/16-18 REGHEXCTRLK	2
49	301251	STEERING WHEEL	1
50	456378	ROLL PIN	1
51	329617	PARTS MANUAL	1
52	329605	OPERATOR'S MANUAL	1

www.emcofire.com

TRACTEUR TONDEUSE 40" MODELE D3560-311

ENSEMBLE CHASSIS & CAPOT (ARRIERE)

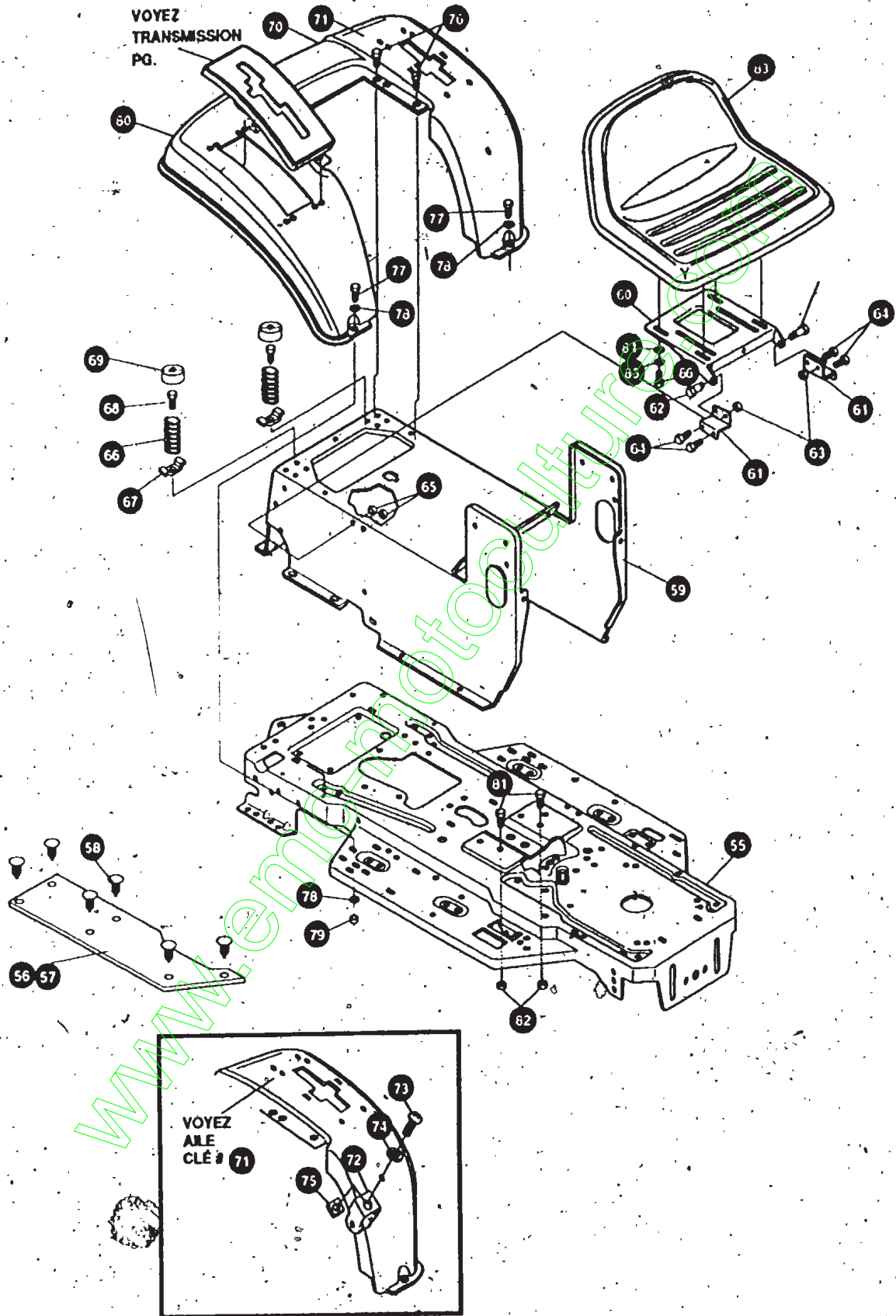

UTILISEZ DES PIÈCES D'ORIGINE POUR CONSERVER L'APPLICATION DE LA GARANTIE.

TOUTES LES PIÈCES NON REFERÉES SONT INTERCHANGEABLES AVEC LEURS OPPOSÉS.

325904A

TRACTEUR TONDEUSE 40" MODELE D3560-311

KEY#	PART#	DESCRIPTION	QTY.
55	326577-860	FRAME, LF MAIN 930/4360	1
56	310005	FOOTPAD LH	1
57	310006	FOOTPAD RH	1
58	309235	FASTENER, RATCHET	12
59	327575-860	CONSOLE GNPR SOF	1
60	58367-860	PLATE, SEAT	1
61	310660-860	BRACKET, F-5 SEAT SUPPORT	1
62	20507	BOLT, .437X .156 HSSH 5/16-18	2
63	1498	NUT, 5/16-18 REGHEXCTRLK	2
64	48901	SCREW, 5/16-18X .63 HHC	4
65	1498	NUT, 5/16-18 REGHEXCTRLK	4
66	57153	SPRING, SEAT 2.63LG, 1.49OD	2
67	1341	CLAMP, SPRING 1, 17"ID	2
68	44811	SCREW, 1/4-20X .75 HWATAP	2
69	56907	COVER, SEAT SPRING 1.5IDX1.0LG	2
70	^	FENDER, ASM F5, SUSP, SOF	1
71	308653-860	FENDER F5, SOF, SUS	1
72	9239	CLEVIS	1
73	439455	SCREW, 5/16-18X.56 PHPNMA	1
74	301551	WASHER, 344IDX1.50X .09	1
75	120373	NUT, 5/16-18 SQ	1
76	995346	SCREW, 1/4-20X .50 WAHTAP	4
77	122017	SCREW, 5/16-18X1.00 HHC	2
78	446363	WASHER, FLAT 375X .88X .082	4
79	1498	NUT, 5/16-18 REGHEXCTRLK	2
80	55023	TRIM, STRIP, BLACK	77.5IN
81	180079	SCREW, 5/16-18X1.00 HHC GR.5	2
82	1498	NUT, 5/16-18 REGHEXCTRLK	2
83	307661	SEAT GENERIC	1
84	120393	WASHER, FLAT .344X .69X .065	4
85	120638	WASHER, HVSP TLK	4
86	122007	SCREW, 5/16-18X.75 HHC	4

TRACTEUR TONDEUSE 40" MODELE D3560-311

ENSEMBLE SUSPENSION TONDEUSE

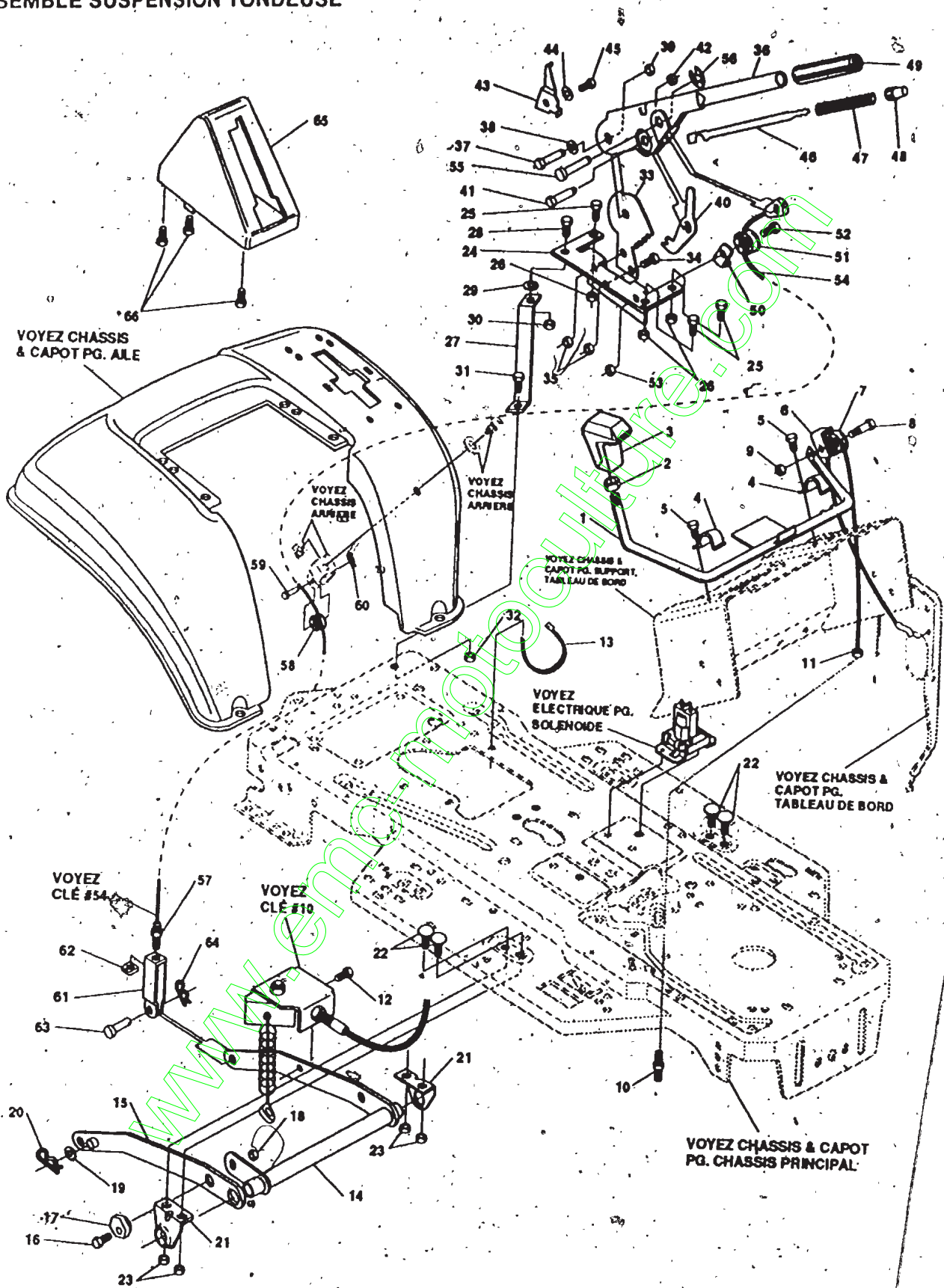

UTILISEZ DES PIECES D'ORIGINE POUR CONSERVER L'APPLICATION DE LA GARANTIE.

TOUTES LES PIECES NON REFEREES SONT INTERCHANGEABLES AVEC LEURS OPPOSEES.

315597F

TRACTEUR TONDEUSE 40" MODELE D3560-311

KEY#	PART#	DESCRIPTION	QTY.
1	9792	ASSY,WELD,CLUTCH HANDLE	1
2	120238	NUT, 1/2-13 HEXJAM	1
3	304438	KNOB,SHIFT NOMA 1/2-13	1
4	9129	CLIP, RETAINING BRKT	2
5	995338	SCREW, 1/4-20X .63 HHWATAP	2
6	1288	BRACKET,CABLE RETAINER	1
7	48306	PULLEY, .906X.305 NYLON	1
8	57322	BOLT, .375X .375 HSSH 1/4-20	1
9	1502	NUT, 1/4-20 REGHEXCTRLK	1
10	301491	ASSY,CL CABLE GEN,RWR	1
11	120613	NUT, 1/4-28 HJAM	1
12	35498	SCREW, 5/16-18X .75 WAHTAP	1
13	57444	TIE, CABLE BLACK NYLON 5.62L	1
14	300158-853	ASSY,REAR LIFT	1
15	300169-853	ASSY.LINK,RIGHT SIDE	1
16	180079	SCREW, 5/16-18X1.00 HHC	1
17	58247	ADJUSTING NUT	1
18	1498	NUT, 5/16-18 REGHEXCTRLK	1
19	417098	WASHER, FLAT .531X1.06X.095	2
20	8260	PIN, HAIR .091 DIA X1.66LG	2
21	58248-853	BRACKET,REAR HANGER SUSP	2
22	126211	BOLT, 5/16-18X .63 CARR	4
23	1498	NUT, 5/16-18 REGHEXCTRLK	4
24	313926	BRACKET,HEIGHT ADJUST	1
25	180077	SCREW, 5/16-18X .75 HHC	3
26	1498	NUT, 5/16-18 REGHEXCTRLK	3
27	300336-860	BRACE, FENDER F-5 SUS	1
28	180079	SCREW, 5/16-18X1.00 HHC	1
29	45602	WASHER, FLAT .333X .87X.119	1
30	1498	NUT, 5/16-18 REGHEXCTRLK	1
31	180079	SCREW, 5/16-18X1.00 HHC	1
32	1498	NUT, 5/16-18 REGHEXCTRLK	1
33	301238	QUADRANT,HEIGHT ADJUST	1
34	180077	SCREW, 5/16-18X .75 HHC	2
35	1498	NUT, 5/16-18 REGHEXCTRLK	2
36	322292-853	HANDLE,LIFT HEIGHT ADJUST	1
37	300171	BOLT, .500X .270 HSSH 5/16-18	1
38	996418	WASHER, FLAT .506X .75X.024	1
39	44108	NUT, 5/16-18 HWDFLCTRLK	1
40	301239	PAWL, HEIGHT ADJUST	1
41	300171	BOLT, .500X .270 HSSH 5/16-18	1
42	44108	NUT, 5/16-18 HWDFLCTRLK	1
43	9435	POINTER,HEIGHT ADJUST	1
44	138479	WASHER, EXLK .195X.41X.03	1
45	35287	SCREW, #8-32X .38 HHWATAPGR2	1
46	303027	ROD,ACTUATOR-SHORT	1
47	58326	SPRING, HEIGHT ADJUST	1
48	58325	KNOB,HEIGHT ADJUST PUSH BUTTON	1
49	58329	GRIP .750 OD W/ HOLE BLK	1
50	9149	BRACKET,CABLE RETAINER	1
51	48306	PULLEY, .906X.305 NYLON	1
52	58336	BOLT, .375X .375 HSSH 1/4-20	1
53	1502	NUT, 1/4-20 REGHEXCTRLK	1
54	314177	CABLE, LIFT 23.30 F-5.20X8-8	1
55	300310	PIN,CLEVIS .310DIA+.475LG	1
56	300311	RING, RET E .31X.24	1
57	120375	NUT, 1/4-20 REGHEX	1
58	48306	PULLEY, .906X.305 NYLON	1
59	300317	PIN, CLEVIS .38 DIA X1.00 LG	1
60	8260	PIN, HAIR .091 DIA X1.66LG	1
61	9405	CLEVIS, LIFT CABLE	1
62	120372	NUT, 1/4-20 REGSQ	1
63	39522	PIN, CLEVIS .312 X .812	1
64	121222	PIN, COTTER .090X.086X.75LG	1
65	300335	LIFT COVER-39" F5	1
66	300340	SCREW, #10 X .75 HHPLAST	3

TRACTEUR TONDEUSE 40" MODELE D3560-311

ENSEMBLE DIRECTION (AVANT)

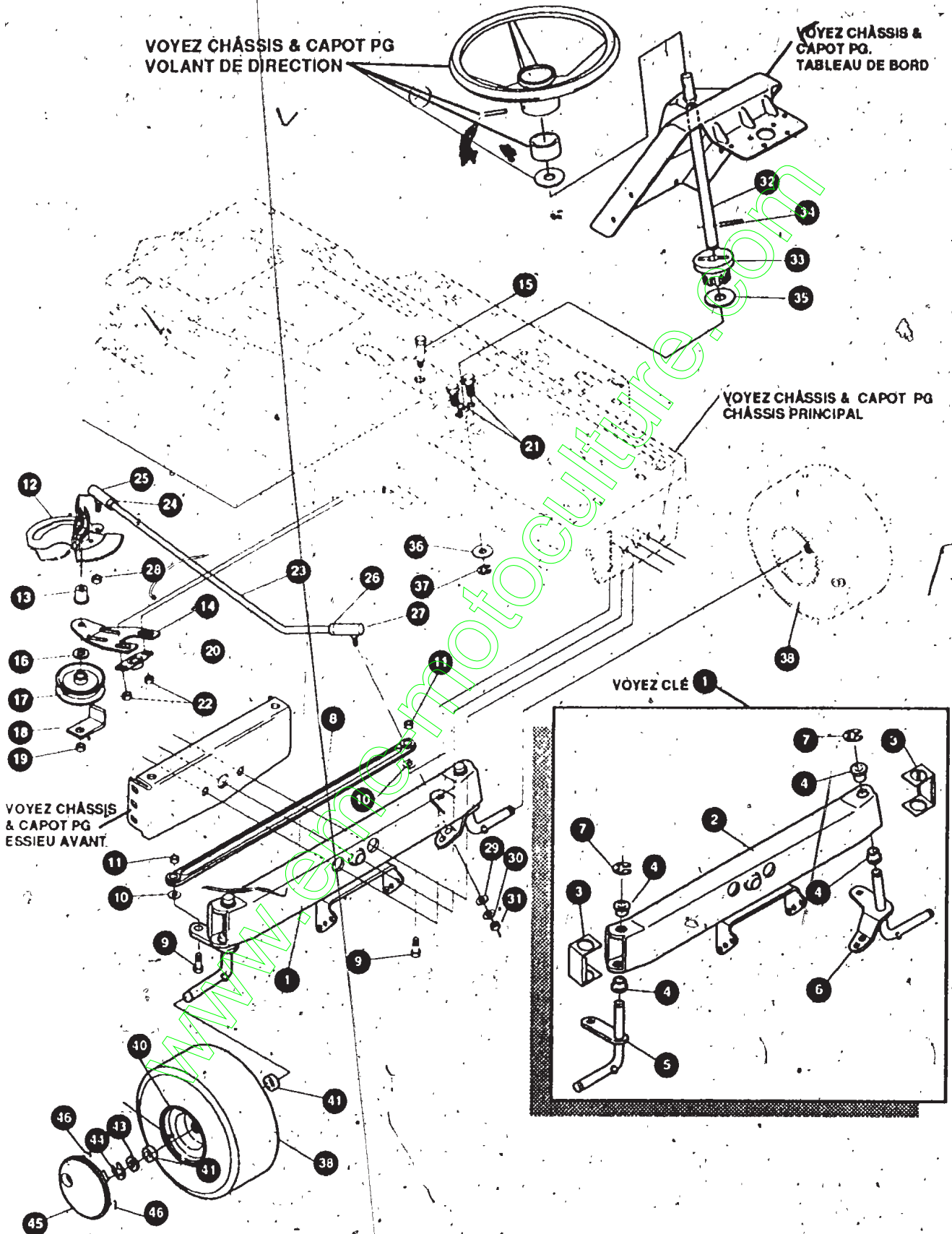

UTILISEZ DES PIÈCES D'ORIGINE POUR CONSERVER L'APPLICATION DE LA GARANTIE.

TOUTES LES PIÈCES NON REFERÉES SONT INTERCHANGEABLES AVEC LEURS OPPOSÉS.

329557A

TRACTEUR TONDEUSE 40" MODELE D3560-311

key#	part#	description	qty.
1		AXLE,FRONT ASSY	1
2	300272-895	ASSY,FRONT AXLE SUS	1
3	53373-895	AXLE COVER	2
4	52407	SPINDLE BEARING	4
5	302926	ASSY,SPINDLE RH LONG	1
6	315886	ASSY,SPINDLE,LH LONG	1
7	36625	RING, RETEX .57X 05TRU5133-75	2
8	304590	TIE ROD ASSY 19.81LG W-SECTION	1
9	180128	SCREW, 3/8-16X1.75 HHC	2
10	120382	WASHER, REGSPTLK 393X.68X.10	2
11	120377	NUT, 3/8 REGHEX.	2
12	313634	ASSY SECTOR GEAR 4WS LF	1
13	313629	BUSHING,SECTOR GEAR 4WS LF	1
14	313671-853	SUPPORT,SECTOR GEAR 4WS LF	1
15	323005	SCREW, BOLT 50 X 2.26 SHWA 3/8-16Z	1
16	25210	WASHER	1
17	35374	PULLEY	1
18	39659	RETAINER, BELT	1
19	1499	NUT, 1/2-13 REGHXCTRLK	1
20	302498	BEARING FLANGE 0.5 BORE	1
21	323731	SCREW, 5/16-24X.75SQ CONE SEMS	2
22	71100	NUT, 5/16-18 HXWDFLLK	2
23	321449	DRAG LINK. 625 DIA LF 4WS	1
24	124925	NUT, 3/8-24 REGHEXJAM	1
25	57158	BALL JOINT 3/8 THD SHORT STUD	1
26	272123	NUT, 7/16-20 HXJAM	1
27	302865	JOINT, BALL ASSY 7/16-20	1
28	46692	NUT, 3/8-24 WDFLHLK WHIZ	1
29	120396	WASHER, FLAT .531X1.06X.095	1
30	120383	WASHER, REGSPTLK 459X.78X 12	1
31	271506	NUT, 7/16-20 REGHX	1
32	313699	SHAFT, STEERING 4WS LF	1
33	302314	PINION STEERING	1
34	302524	PIN DOWEL STR ERO LT	1
35	315194	WASHER, FLAT 1.38 X .51X.043	1
36	2968	WASHER, FLAT .504X.75X.059	1
37	20864	RING, RET E .39X 04TRU5133-50	1
38	316702	TIRE & RIM 15X6-6	2
39	24167	VALVE STEM	1
40	321503	WHEEL W/BEARING	1
41	314416	BEARING	2
43	642	WASHER, FLAT .755X1.31X.075	4
44	36625	RING RETEX .57X 05 TRVARC 5133-75	2
45	304444	HUB CAP-EURO GENERIC	2
46	306669	CLIP	8

* ORDER INDIVIDUAL PARTS.

TRACTEUR TONDEUSE 40" MODELE D3560-311

ENSEMBLE DIRECTION (ARRIERE)

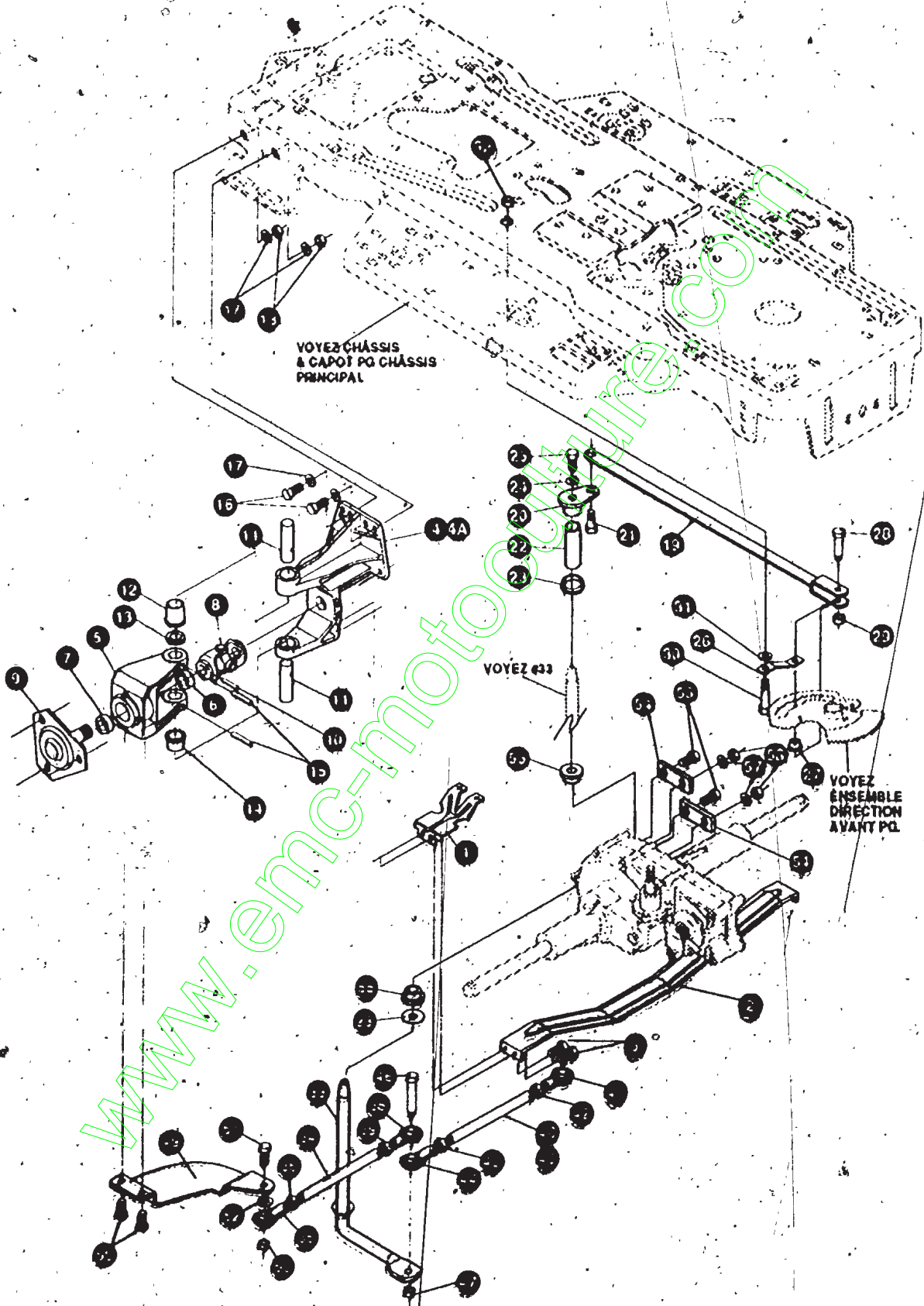

UTILISEZ DES PIECES D'ORIGINE POUR CONSERVER L'APPLICATION DE LA GARANTIE.

TOUTES LES PIECES NON REFEREES SONT INTERCHANGEABLES AVEC LEURS OPPOSEES.

325379C

TRACTEUR TONDEUSE 40" MODELE D3560-311

KEY#	PART#	DESCRIPTION	QTY.
1.	313645-853	BRKT X-AXLE MTG 4WS HYDRO	2
2.	322959-853	BRACKET HYDRO 4WS SUPPORT	1
3.	50634	SCREW, 5/16-18X .88 WAHHTAP	4
4	325378	SF U-JOINT, 4WS HEAVY DUTY	1
4A	314267	BRACKET, STEERING PIVOT DRILLED	2
5.	315267	BRACKET, STR PIVOT 6204 BEARING	2
6	12325	BRNG, BALL 750IDX1.575ODX.472	2
7.	315268	BRNG, BALL 8750IDX1.850DX.55	2
8.	12290	U-JOINT ASSEMBLY W/ZERK (SHORT)	2
9	315264-830	HUB ASSEMBLY HEAVY	2
10	36311	PIN, GROOVED 250 DIA X 1.50 LG	2
11	12289	PIN, STEERING HINGE	4
12	12288	BRNG, FL SH . IDX . ODX	2
13	21682	WASHER, FLAT 765X1.25X.042 PL	2
14	12321	BRNG, FLSH IDX . ODX	2
15	456722	PIN, SPRING 250 DIA X 1.50 LG HV PL	4
16	122017	SCREW, 5/16-18X1.00 HHC GR2	6
17	120393	WASHER, FLAT 344X.69X.065	14
18	1498	NUT, 5/16-18 REG HEX CTRLK	8
19	322400-853	BAR, DRAGLINK LF4WS(HYDRO)	1
20	308719	PIVOT, STEERING	1
21	322401	BOLT, 562X 340 HSSH 3/8-24	1
22	322402	SPACER, STEERING SHAFT HYDRO	1
23.	25177	WASHER, FLAT 765X1.19X.048	2
24	45602	WASHER, FLAT 333X 87X.119	1
25	421051	SCREW, 5/16-24X1.00 HHC GR8 P	1
26	302594	MF. FOLLOWER, ROLLER	1
27	304116	CAM YOKE ROLLER	1
28	304122	BOLT, SHOULDER CAM ROLLER	1
29	274654	NUT, 1/2-20 REG HEX CTRLK GRB	1
30	324638	BOLT, SHOULDER CAM FOLLOWER	1
31.	996307	WASHER, FLAT 391X1.00X.209	1
32	412349	NUT, 3/8-24 HX CTRLK	1
33	323189	SHAFT, STEERING PIVOT (ZN)	1
34	323636	TIE ROD ASSY RH EURO 4WS & LFHYDR	1
35	308384	BALL JOINT LH 3/8-24	1
36.	124925	NUT, 3/8-24 REG HEX JAM	1
37	313642	ROD, TIE 1/2" D X 7.00 LG	1
38	304260	BALL JOINT RH 3/8-24	1
39	308399	NUT, 3/8-24 LH THD REG HJAM	1
40	323637	TIE ROD ASSY LH EURO 4WS & LFHYDR	1
41.	308384	BALL JOINT LH 3/8-24	1
42.	124925	NUT, 3/8-24 REG HEX JAM	1
43.	313643	ROD, TIE 1/2" D X 11.30 LG ZINC	1
44.	304260	BALL JOINT RH 3/8-24	1
45.	308399	NUT, 3/8-24 LH THD REG HJAM	1
46	181646	SCREW, 3/8-24X1.75 HHC GR5	1
47.	412349	NUT, 3/8-24 HX CTRLK	1
48	304120-853	ARM REAR WHL STR (FER) R.H	1
49.	304121-853	ARM, REAR WHEEL STEER L.H.	1
50.	47792	SCREW, 3/8-16X1.00 WAHHTAP BLK	4
51	181639	SCREW, 3/8-24X1.25 HHC GR5	2
52.	120382	WASHER, REGSPTLK.393X.68X.10	2
53	412349	NUT, 3/8-24 HX CTRLK	2
54.	314511	BRACKET, REAR PIVOT HYDRO	2
55	302303	BEARING SPINDLE FR W/HOLE	2
56.	44811	SCREW, 1/4-20X .75 HX WATAP	2
57	120380	WASHER, REGSPTLK 263X.49X.07	2
58.	120375	NUT, 1/4-20 REG HEX	2

TRACTEUR TONDEUSE 40" MODELE D3560-311

TRANSMISSION

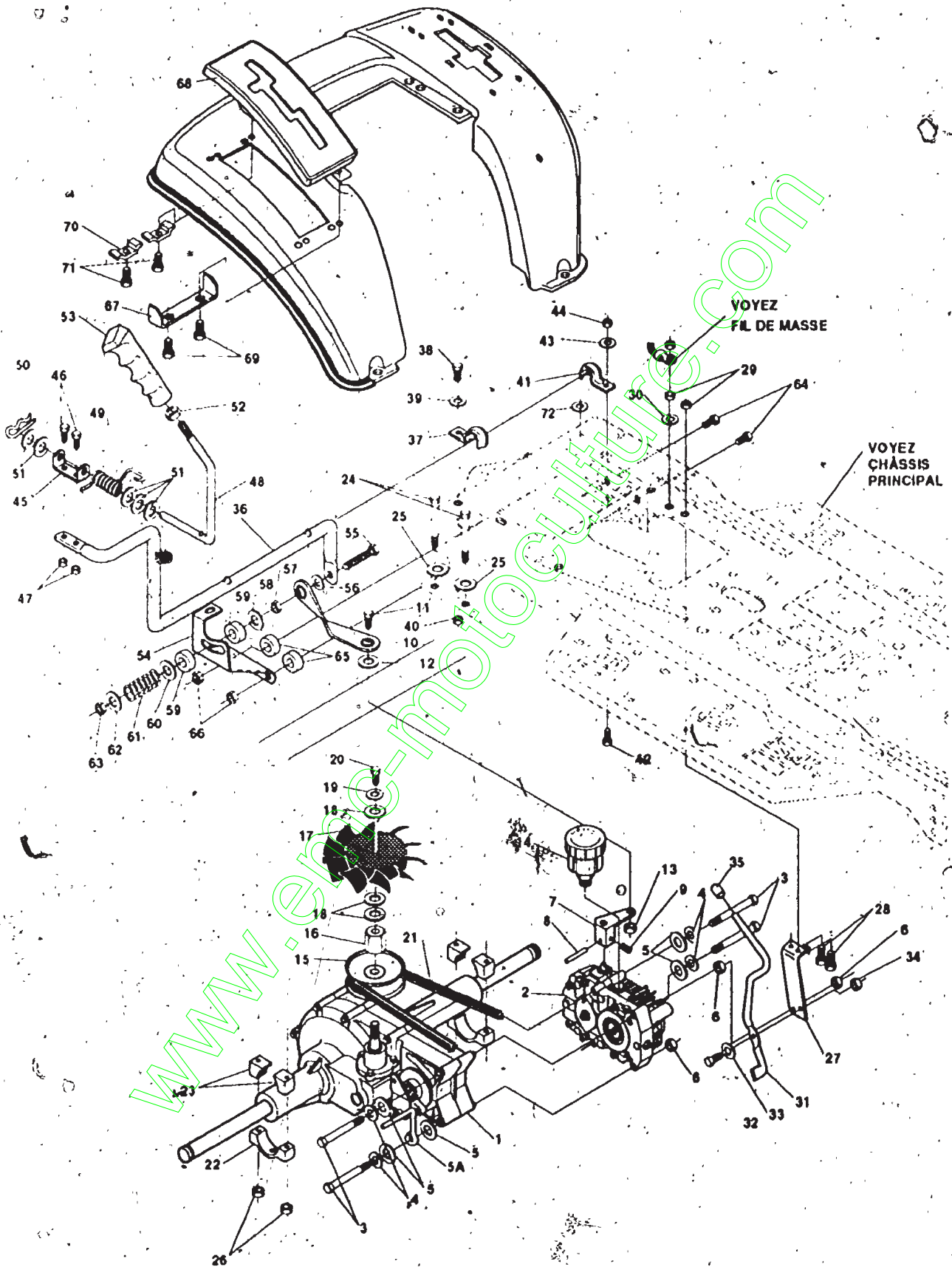

UTILISEZ DES PIECES D'ORIGINE POUR CONSERVER L'APPLICATION DE LA GARANTIE.

TOUTES LES PIECES NON
REFEREES SONT
INTERCHANGEABLES AVEC
LEURS OPPOSEES.

329554A

TRACTEUR TONDEUSE 40" MODELE D3560-311

KEY#	PART#	DESCRIPTION	QTY.
1	314507	TRANSAXLE, AGR/FAB/HYDRO 4WS	1
2	310227	HYDROSTATIC PUMP, BDU-10S-114	1
3	189299	SCREW, 5/16-18X4.50 HHC	4
4	120638	WASHER, HVSPTLK .328X.60X.09	4
5	120393	WASHER, FLAT .344X.69X.065	5
5A	55480	GUIDE, BELT	1
6	1498	NUT, 5/16-18 REGHEXCTRLK	3
7	310180	ARM SPEED CONTROL HYDRO	1
8	456652	PIN, SPRING.187DIA X .88LG	1
9	102570	SCREW, 1/4-20X .38 ALHSETCPPT	1
10	314236	LINK, SHIFT LF HYDRO	1
11	122145	SCREW, 3/8-16X1.25 HHC	1
12	120382	WASHER, REGSPLTLK .393X.68X.10	1
13	1499	NUT, 3/8-16 REGHXCTRLK	1
14	310786	RESERVOIR, HYDRO	1
15	322403	PULLEY ASSY HYDRO 4WS	1
16	322404	NUT PULLEY 1/2-20 AND 1/4-20 4WS	1
17	308523	FAN, HYDRO 7.00DIA-10 BLADES	1
18	908492	WASHER, FLAT .28X1.38X.07	3
19	120380	WASHER, REGSPTLK .263X.49X.07	1
20	180018	SCREW, 1/4-20X .62 HHC	1
21	314572	BELT, V 4L 80 16 HYDRO LF	1
22	310187	MOUNTING BLOCKS HYDRO	2
23	310813	MOUNTING BLOCK LH HYDRO	4
24	120393	WASHER, FLAT .344 X .69 X .065	4
25	180089	SCREW, 5/16-18X2.75 HHC	4
26	44108	NUT, 5/16-18 HWDFLCTRLK	4
27	314221	STABILIZER BRACKET LF HYDRO	1
28	122017	SCREW, 5/16-18X1.00 HHC	2
29	1498	NUT, 5/16-18 REGHEXOTRLK	2
30	138538	WASHER, REGINLK .320X.61X.03	1
31	314222	ROD-DUMP VALVE LF HYD.ZINC	1
32	310088	BOLT, .250X .312 HSSH 5/16-18	1
33	2483	WASHER, 391DX1.25DX.07 BELLVIL	1
34	1502	NUT, 1/4-20 REGHEXCTRLK	1
35	7289	RUBBER STOP	1
36	319115	LEVER, SHIFT LWR LF HYDRO	1
37	310347-853	CLIP-SHIFT LEVER .62 ROD	1
38	180077	SCREW, 5/16-18X.75 HHC	1
39	996416	WASHER, FLAT .391X1.00X.125	1
40	1498	NUT, 5/16-18 REGHEXCTRLK	1
41	310347-853	CLIP-SHIFT LEVER .62 ROD	1
42	180077	SCREW, 5/16-18 REGHEXCTRLK	1
43	996416	WASHER, FLAT .391X1.00X.125	1
44	1498	NUT, 5/16-18 REGHEXCTRLK	1
45	310213-953	PIVOT BRKT LEVER	1
46	180018	SCREW, 1/4-20X .62 HHC	2
47	1502	NUT, 1/4-20 REGHEXCTRLK	2
48	318452	LEVER, SHIFT UPPER SF 1/2-13TH	1
49	318451	SPRING, TORS. .56X.95X.095	1
50	8260	PIN, HAIR .125 DIA X 1.00 LG	1
51	2968	WASHERS	5
52	120238	NUT, 1/2-13 HEXJAM	1
53	306690	HANDLE 1/2-13 MOLDED BLACK 173	1
54	314473-853	QUADRANT, SPEED CONTROL	1
55	7288	SCREW, 3/8-16X3.00 HHCFT	1
56	120382	WASHER, REGSPLTLK .393-16X3.00	1
57	45171	NUT, 3/8-16 HWDFL WHIZ NUT	1
58	845	WASHER, FLAT .390X1.25X.119	1
59	314944	WASHER, FRICTION	2
60	845	WASHER, FLAT .390X1.25X 119	1
61	29170	SPRING	1
62	274517	WASHER, FLAT .406X.73X.063	1
63	1499	NUT, 3/8-16 REGHXCTRLK	1
64	180083	SCREW, 5/16-18X1.50 HHC	2
65	314702	SPACER .344 X 1.00 X .500	2
66	1498	NUT, 5/16-18 REGHEXCTRLK	2
67	311257-853	BRACKET COVER	1
68	314244	COVER PLASTIC	1
69	311331	SCREW, 174-15X.44/.533 HILOHWA	2
70	300284-953	CLAMP SPRING	2
71	311331	SCREW, 174-15X 44/.533 HILOHWA	2
72	309436	PUSHNUT, 5/16 BOLT RETAINER	1

TRACTEUR TONDEUSE 40" MODELE D3560-311

TRANSMISSION

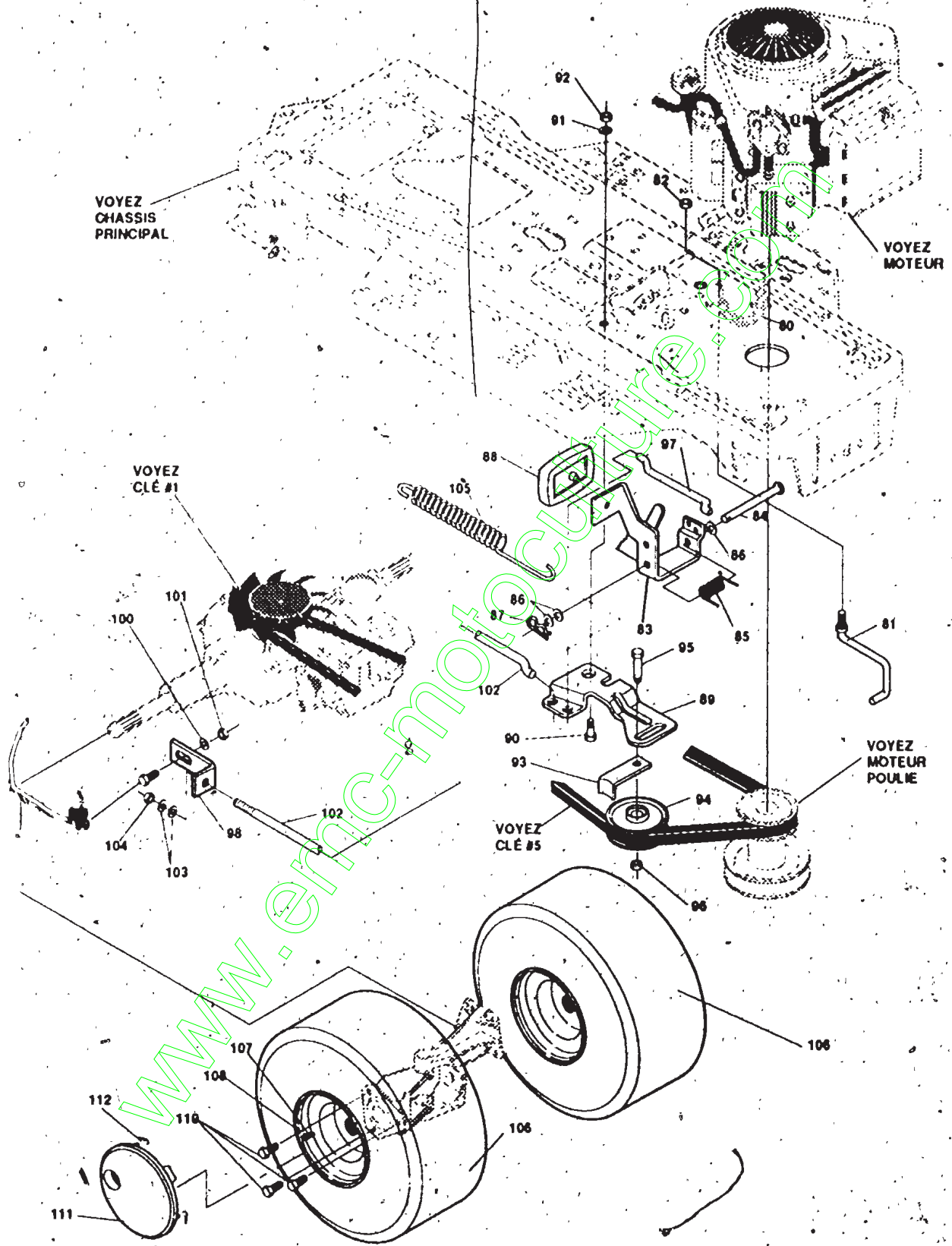

UTILISEZ DES PIECES D'ORIGINE POUR CONSERVER L'APPLICATION DE LA GARANTIE.

TOUTES LES PIECES NON REFEREES SONT INTERCHANGEABLES AVEC LEURS OPPOSEES.

329554A

TRACTEUR TONDEUSE 40" MODELE D3560-31 i

key#	part#	description	qty.
80	321514	SPRING BIAS DRAGLINK	1
81	304016	GUIDE BELT	1
82	1498	NUT, 5/16-18 REGHEXCTRLK	1
83	325942	PEDAL ASSY, BRAKE/CLUTCH LF	1
84	319675	PIN, CLEVIS	1
85	57847	SPRING, BRAKE PEDAL	1
86	2968	WASHER, FLAT 504X .75X .059	3
87	56180	PIN, HAIR	1
88	48160	PAD, CLUTCH BRAKE W/PRINTING	1
89	320381	ARM, IDLER TRACTION DR. LF	1
90	300793	BOLT, .625X .135 HSH 5/16-18	1
91	45602	WASHER, FLAT 333X .87X .119	1
92	1498	NUT, 5/16-18 REGHEXCTRLK	1
93	39659	RETAINER, STRAP BELT	1
94	35374	PULLEY, IDLER V4L 3.06X .62	1
95	45892	BOLT, 3/8-16X1.50 CARR	1
96	1499	NUT, 3/8-16 REGHEXCTRLK	1
97	57204	ROD, CLUTCH	1
98	57217	BRACKET, BRAKE ROD	1
99	20507	BOLT, .437X .156 HSH 5/16-18	1
100	45602	WASHER, FLAT 333X .87X .119	1
101	1498	NUT, 5/16-18 REGHEXCTRLK	1
102	316293	ROD, BRAKE LT 920 LF 22 25	1
103	120393	WASHER, FLAT 344X .69X .065	2
104	1498	NUT, 5/16-18 REGHEXCTRLK	1
105	325123	SPRING, CLUTCH 16.01X .750X .688	1
106	319684	TIRE & RIM 20 X 10-8	2
107	24167	VALVE STEM	1
108	12467	RIM, WHEEL	1
110	123418	SCREW, 1/2-20 X .50 HHC	6
111	304441	HUB CAP, 8" GENERIC	2
112	306669	CLIP	10

www.emc-machinery.com

TRACTEUR TONDEUSE 40" MODELE D3560-311

MOTEUR ENSEMBLE

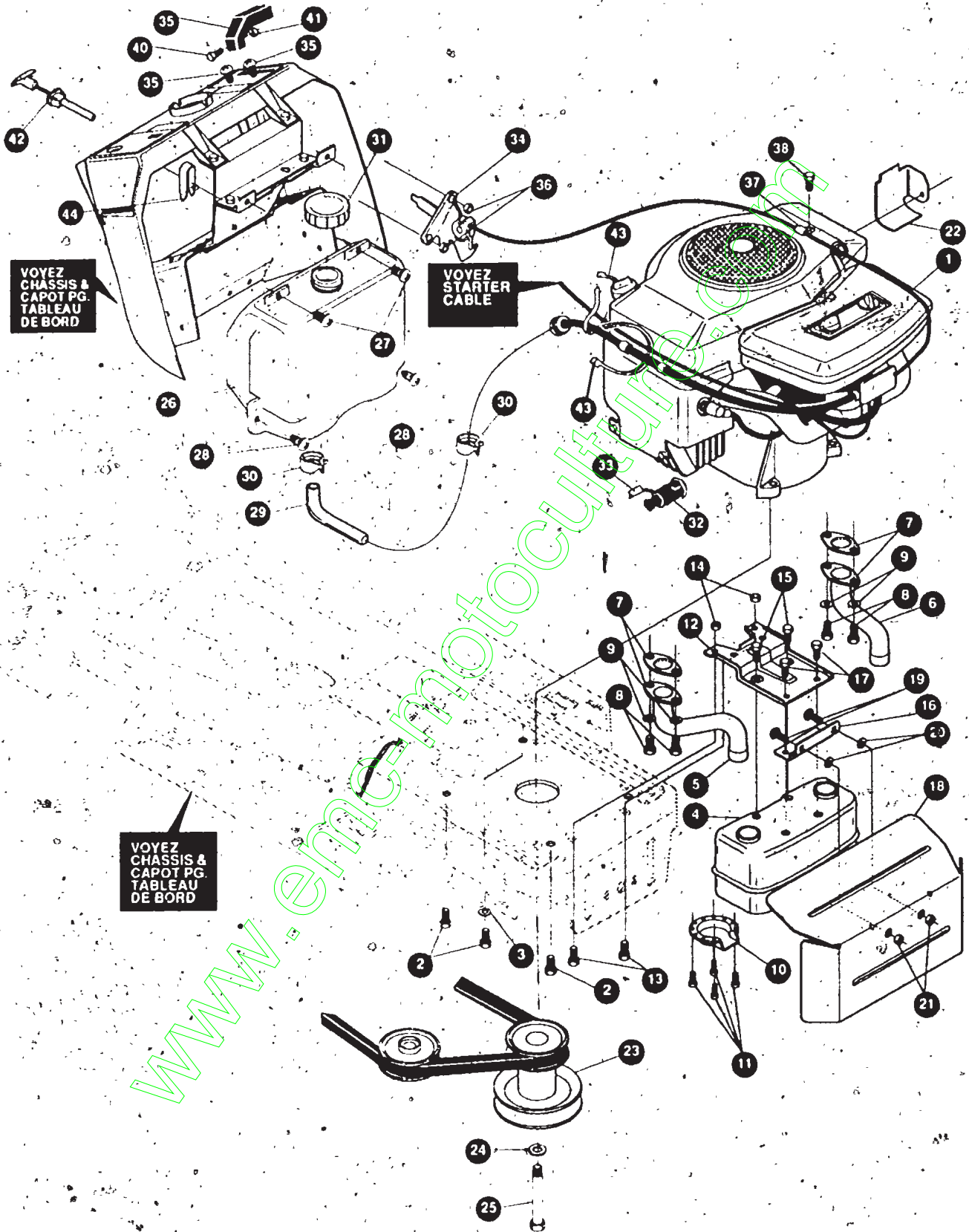

UTILISEZ DES PIÈCES D'ORIGINE POUR CONSERVER L'APPLICATION DE LA GARANTIE.

TOUTES LES PIÈCES NON REFERÉES SONT INTERCHANGIBLES AVEC LEURS OPPOSÉS.

329553A

TRACTEUR TONDEUSE 40" MODELE D3560-311

key#	part#	description	qty.
1		ENGINE, 14-18HPBSTWIN OPPOSED V/C DUAL CIRCUIT1	1
2	• 50947	SCREW, 3/8-16X1.25 WAHTAP	4
3	138489	WASHER, EXLK 384X 69X.04	1
4	305550	MUFFLER 15HP B&S VANG 18 TWIN	1
5	305552	EXHAUST TUBE 18HP RH B&S VANG	1
6	305551	EXHAUST TUBE 18HP LH B&S VANG	1
7	56440	GASKET MUFFLER	2
8	180020	SCREW, 1/4-20X 75 HHC GR5	4
9	120380	WASHER, REGSPTLK .263X.49X.07	4
10	56472	DEFLECTOR SIDE OUT (BS222573)	1
11	• 35287	SCREW, #8-32X .38 HHWATAPGR2	4
12	304709-853	BRACKET, MUFFLER	1
13	• 56030	SCREW, 5/16-18X.75WDFLLK	2
14	• 55273	NUT, 5/16-18 HXWDFLLK	2
15	• 995346	SCREW, 1/4-20X .50 WAHTAP	2
16	9796	BRACKET, TRANSAXLE	1
17	• 995338	SCREW, 1/4-20X .63 HHWATAP	2
18	308644-853	HEAT SHIELD, MUFFLER 14-18 TWIN OPP	1
19	126211	BOLT, 5/16-18X .63 CARR	2
20	309436	PUSHNUT, 5/16 BOLT RETAINER	2
21	• 55273	NUT, 5/16-18 HXWDFLLK	2
22	56470-853	DEFLECTOR COOL AIR	1
23	328028	PULLEY, ENG 4 40OFF/5 00D/3 00D 40" GEAR	1
24	• 120383	WASHER, REGSPTLK .459X 76X 12	1
25	• 433146	SCREW, 7/16-20X4 25 HHC	1
26	314991	TANK, FUEL 2-GAL GPWR	1
27	• 300303	SCREW, 1/4-10X .75RHPNTAPGR2	2
28	995346	SCREW, 1/4-20X 50	2
29	47452	GAS LINE 25ID BULK LENGTH	15 50
30	47345	CLAMP, FUEL LINE	2
31	300304	CAP, FUEL - 2 0 THROAT	1
32	325547	OIL DRAIN ITW	1
33	327422	OIL DRAIN CAP	1
34	300510	THROTTLE CONTROL 31 50LG	1
35	• 320553	SCREW, 10-24X .63PHPNMA GR2BK	2
36	• 271166	NUT, #10-24 HEX REPS	2
37	57569	RETAINER, 311DX.62X.03 WIRE	1
38	35258	SCREW #10-24X .38 SLHWATAP GR2	1
39	300508	KNOB, THROTTLE CONTROL HANDGRIP	1
40	• 159585	SCREW, #8-32X .38 PHPNMA	1
41	• 120622	NUT, #8-32 REGHX	1
42	300425	CHOKE CONTROL 31.5LG .12PAN	1
43	57444	TIE, CABLE BLACK NYLON 5.621	2
44	314522	CLIP, CHOKE RETAINER	1

- SEE ENGINE MANUAL
- Indicates STANDARD HARDWARE ITEMS

TRACTEUR TONDEUSE 40" MODELE D3560-311

CARTER DE TONDEUSE

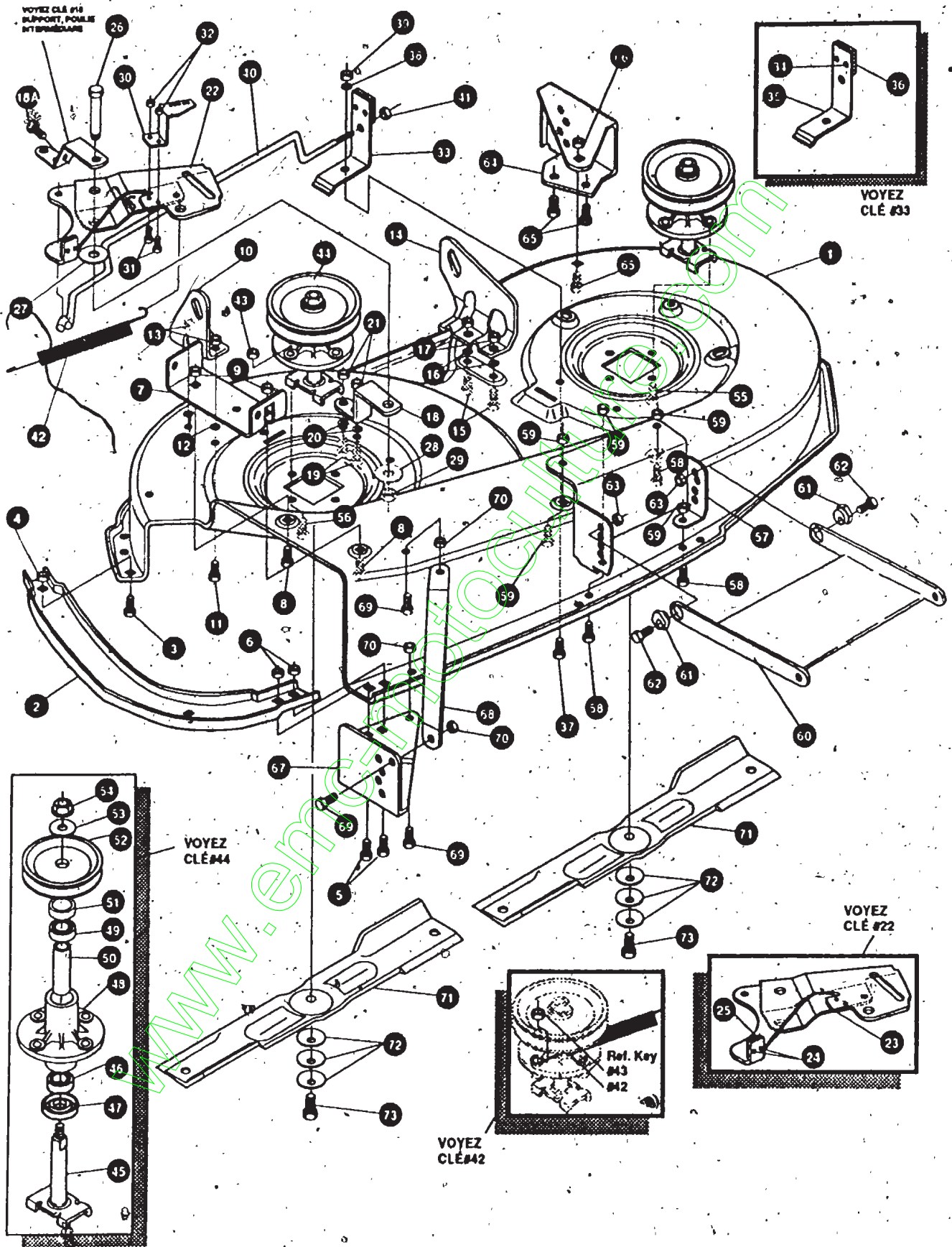

UTILISEZ DES PIECES D'ORIGINE POUR CONSERVER L'APPLICATION DE LA GARANTIE.

TOUTES LES PIECES NON REFEREES SONT INTERCHANGEABLES AVEC LEURS OPPOSEES.

320109G

TRACTEUR TONDEUSE 40" MODELE D3560-311

KEY#	PART#	DESCRIPTION	QTY.
1.	325103-853	MOWER DECKS, RIDER 40"	1
2.	328480-853	TOE GUARD	1
3.	180075	SCREW, 5/16-18X .63 HHC	1
4.	1498	NUT, 5/16-18 REGHEXCTRLK	1
5.	122007	SCREW, 5/16-18X .75 HHC	2
6.	1498	NUT, 5/16-18 REGHEXCTRLK	2
7.	317017	BRACKET CHUTE MOUNT	1
8.	180075	SCREW, 5/16-18X .63 HHC	2
9.	1498	NUT, 5/16-18 REGHEXCTRLK	2
10.	313929	BRACKET, RH LIFT REAR	1
11.	180077	SCREW, 5/16-18X .75 HHC	2
12.	120393	WASHER, FLAT .344X .69X.065	2
13.	1498	NUT, 5/16-18 REGHEXCTRLK	2
14.	310667	BRACKET, LH LIFT REAR	1
15.	180077	SCREW, 5/16-18X .75 HHC	2
16.	120393	WASHER, FLAT .344X .69X.065	2
17.	1498	NUT, 5/16-18 REGHEXCTRLK	2
18.	326893-853	BRACE IDLER	1
18A	308231	SCRW, 1/4-20X1.25 HHWATAP	1
19.	180077	SCREW, 5/16-18X .75 HHC	2
20.	120393	WASHER, FLAT .344X .69X.065	2
21.	44108	NUT, 5/16-18 HWDFLCTRLK	2
22.	320576-853	IDLER ARM ASSEMBLY	1
23.	322116-853	ARM IDLER 40"DECK EURO	1
24.	41601	RIVET, OVSET .187DIA X .50	2
25.	306973	BRAKE PAD - HARD	1
26.	304420	BOLT, .500X2.15 HXHDCPSH	1
27.	996307	WASHER, FLAT .391X1.00X.209	1
28.	996416	WASHER, FLAT .391X1.00X.126	2
29.	45171	NUT, 3/8-16 HWDFL WHIZ-LOCK	1
30.	326249-853	BRACKET, EXTENSION IDLER	1
31.	180075	SCREW, 5/16-18 X .63 HHC	2
32.	1498	NUT, 5/16-18 REGHEXCTRLK	2
33.	321828	BLADE BRAKE ASSY	1
34.	135624	RIVET, TRSET .185DIA X .41LG	2
35.	304119-853	BRAKE ARM	1
36.	306973	BRAKE PAD	1
37.	180075	SCREW, 5/16-18X .63 HHC	1
38.	120393	WASHER, FLAT .344X .69X.065	1
39.	1498	NUT, 5/16-18 REGHEXCTRLK	1
40.	302714	ROD, BRAKE	1
41.	1502	NUT, 1/4-20 REGHEXCTRLK	1
42.	35410	SPRING .071 X .62 X 4.37	1
43.	1498	NUT, 5/16-18 REGHEXCTRLK	1
44.	56424-853	QUILL ASSY, 36/39/40/43	2
45.	56423	SHAFT/SADDLE 36"	1
46.	49562	BRNG, BALL .669IDX1.575ODX.472	1
47.	50816	DUST SHIELD	1
48.	55547	QUILL CASTING (1046)	1
49.	49562	BRNG, BALL .669IDX1.575ODX.472	1
50.	50818	SPACER, SLEV .669X .88X3.797	1
51.	51449	SPACER, SLEV .872X .93X .438PM	1
52.	313898	PULLEY, 26/36" QUILL	1
53.	56385	WASHER, SPECIAL QUILL	1
54.	1282	NUT, 7/16-20 WDFLLK	1
55.	50634	SCREW, 5/16-18X .88 WAHHTAP	7
56.	300345	SCREW, 5/16-18X1.38 WATAP	1
57.	318445	BRACKET, 40 LF FRONT DECK	1
58.	180075	SCREW, 5/16-18X .83 HHC	4
59.	1498	NUT, 5/16-18 REGHEXCTRLK	4
60.	58305-853	BRACKET, LINK DECK FRONT	1
61.	58247	ADJUSTING NUT	2
62.	122017	SCREW, 5/16-18X1.00 HHC	2
63.	1498	NUT, 5/16-18 REGHEXCTRLK	2
64.	317041	BRACKET, GAGE WHEEL L.H.	1
65.	180075	SCREW, 5/16-18X .63 HHC	3
66.	1498	NUT, 5/16-18 REGHEXCTRLK	3
67.	322464-853	BRACKET, GAGE WHEEL R.H. FRNT	1
68.	314282-853	BRACKET, STABILIZER	1
69.	180075	SCREW, 5/16-18X .63 HHC	3
70.	1498	NUT, 5/16-18 REGHEXCTRLK	3
71.	313316	BLADE, 40" STD-LIFT 20.924	2
72.	2483	WASHER, .39IDX1.25DX.07 BELLVL	6
73.	39573	SCREW, 3/8-24X1.00 NYLHHC	2

TRACTEUR TONDEUSE 40" MODELE D3560-311

CARTER DE TONDEUSE

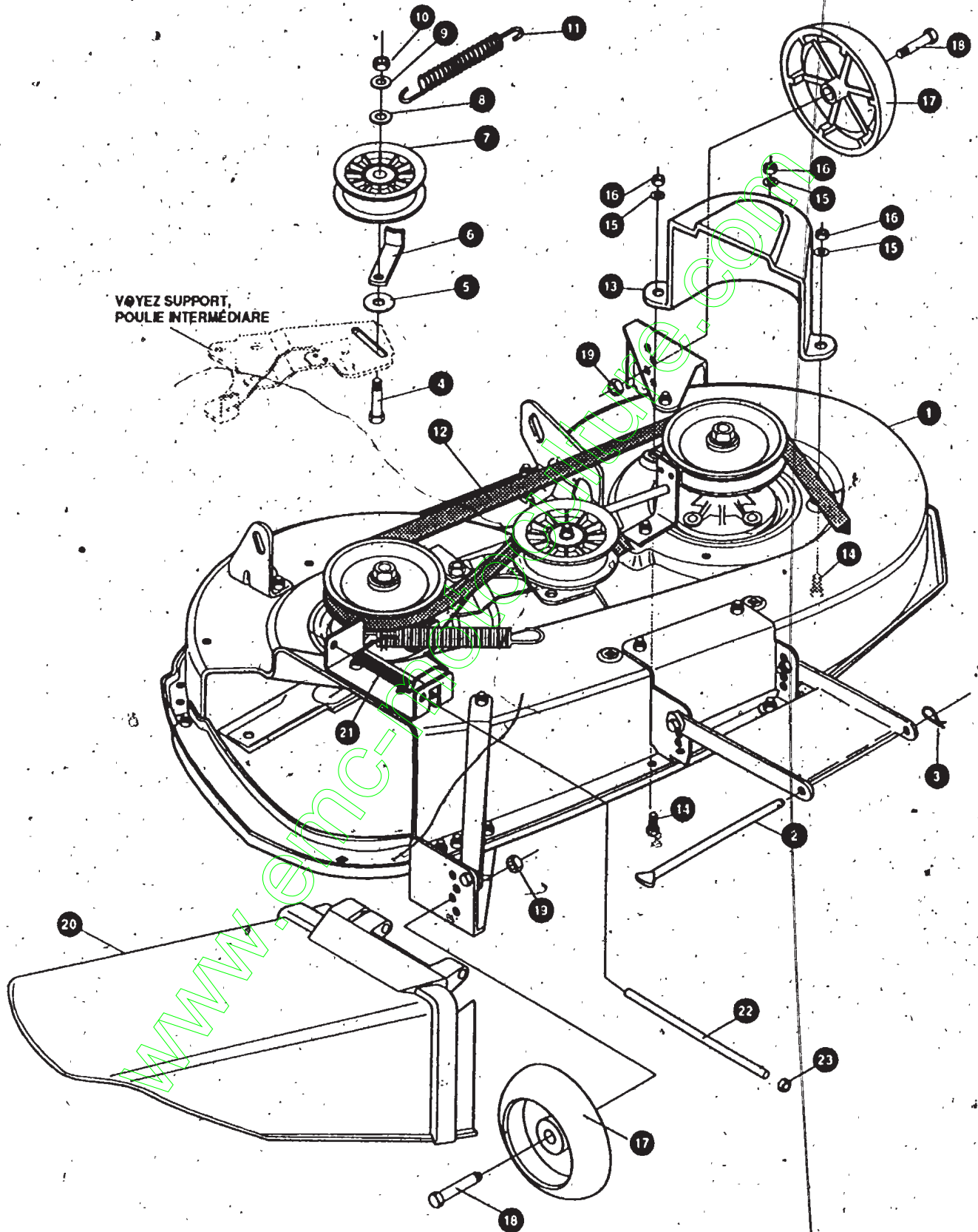

UTILISEZ DES PIÈCES D'ORIGINE POUR CONSERVER L'APPLICATION DE LA GARANTIE.

TOUTES LES PIÈCES NON REFERÉES SONT INTERCHANGEABLES AVEC LEURS OPPOSÉS.

325682B

TRACTEUR TONDEUSE 40" MODELE D3560-311

KEY#	PART#	DESCRIPTION	QTY.
1.	^	DECK,40" MOWER 2-WH EXPORT	1
2	58306	ROD, DECK HITCH	1
3	8260	PIN, HAIR .091 DIA X 1.66LG	1
4.	57325	BOLT, 3/8-16X2.00 CARR	1
5.	25210	WASHER, FLAT .392X1.25X.09	1
6.	1346	RETAINER, BELT	1
7.	310326	PULLEY, IDLER BFF 4.00 WIDE FL	1
8.	996307	WASHER, FLAT .391X1.00X.209	1
9.	120382	WASHER, REGSPTLK.393X.68X.10	1
10.	120377	NUT, 3/8-16 REGHX	1
11.	300473	SPRING, TENSION 7.52LG+17LB/IN	1
12.	319005	BELT, V 5L 81.00 DECK 40 LF	1
13	328257	GUARD, BELT LH PLASTIC	1
14.	180075	SCREW, 5/16-18X .63 HHC	3
15	120393	WASHER, FLAT .344X .69X.065	3
16	1498	NUT, 5/16-18 REGHEXCTRLK	3
17	302611	GAGE WHEEL, EURO	2
18	23763	SHOULDER BOLT	2
19	1499	NUT, 3/8-16 REGHEXCTRLK	2
20.	304422	CHUTE DEFLECTOR40"-43"	1
21	314975	SPRING TORSION	1
22	304424	ROD, PIVOT DECK	1
23	3535	PUSH NUT	1

^ ORDER DECK KIT# 329035 FOR COMPLETE DECK.

www.emc-motoculture.com

TRACTEUR TONDEUSE 40" MODELE D3560-311

FAISCEAU ELECTRIQUE

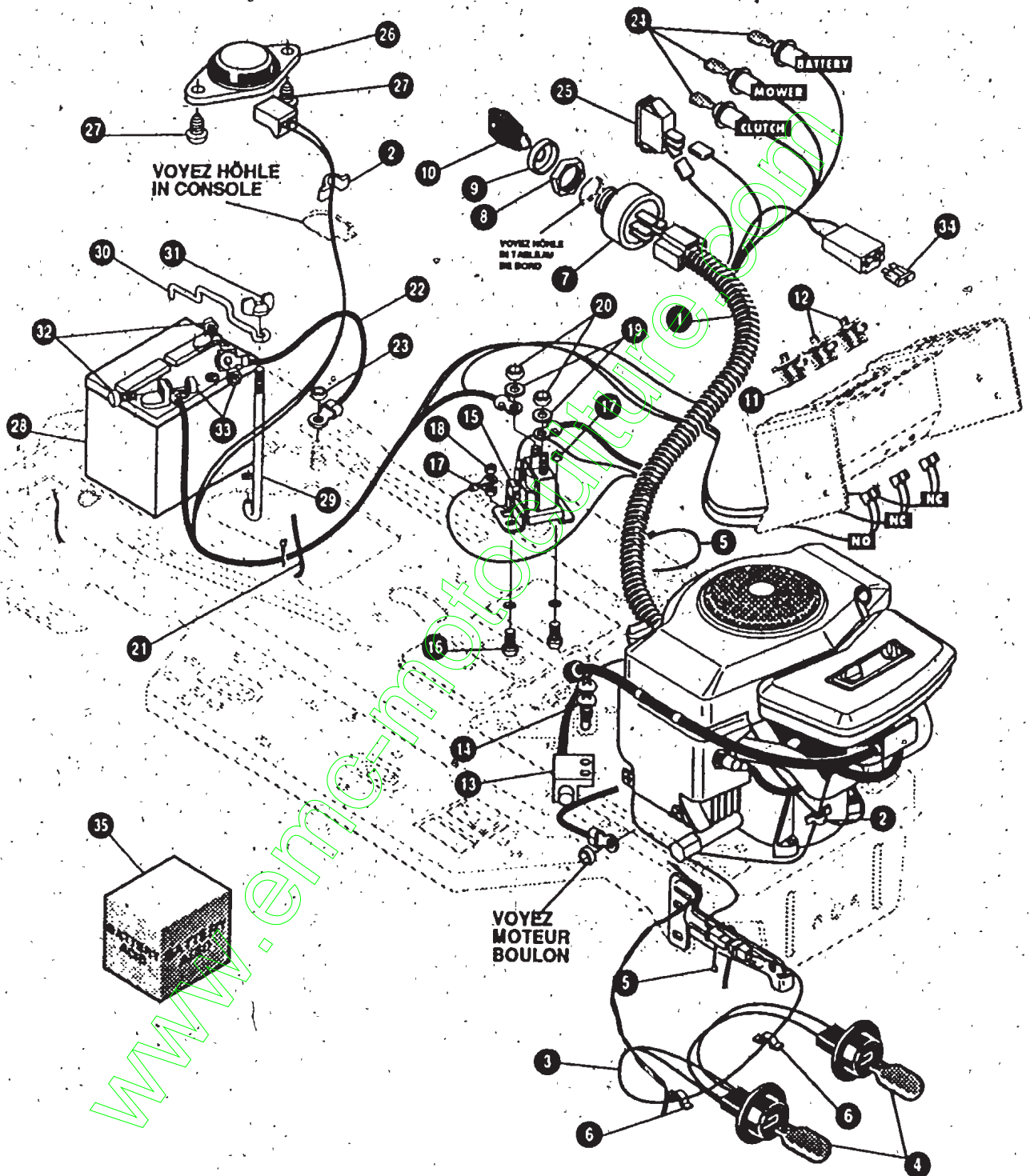

UTILISEZ DES PIECES D'ORIGINE POUR CONSERVER L'APPLICATION DE LA GARANTIE.

TOUTES LES PIECES NON REFEREES SONT INTERCHANGEABLES AVEC LEURS OPPOSEES.

325532C

TRACTEUR TONDEUSE 40" MODELE D3560-311

KEY#	PART#	DESCRIPTION	QTY.
1.	324521	HARNES, 14-18HP TWIN OPP., HY-G14, WRAP, LF DUAL CIRCUIT	1
2	41482	PRESS CLIP, 1.380LG 255ID	2
3.	303064	ASSY, LIGHT WIRE-1/4 TURN	1
4.	52572	BULB, HEADLAMP	2
5.	57444	TIE, CABLE BLACK NYLON 5 62L	2
6.	41482	PRESS CLIP, 1.380LG 255ID	2
7.	327355	SWITCH-IGN (AFTER FIRE) 3 POSN	1
8.	327352	NUT, 5/8-32 ACC #125 PLAST BLK	1
9.	300194	BOOT, IGN SWITCH	1
10.	327350	KEY, IGNITION SWITCH	1
11.	326653	SWITCH, SNAPMNT NO .055/ .116BLK	1
12.	326654	SWITCH, SNAPMNT NC 140 BLUE	2
13.	57476	SWITCH, SCR MNT DP NC NO BLK	1
14.	57220	SCREW, #12 X .50 PHPNHTAP BLK	2
15.	53716	SOLENOID	2
16.	187745	SCREW, 1/4-20X .75 HXSEMMA	2
17.	1502	NUT, 1/4-20 REGHEXCTRLK	2
18.	271172	NUT, 1/4-20 REGHEXKEPS	1
19.	138485	WASHER, EXLK 320X 61X 03	2
20.	120368	NUT, 5/16-24 REGHEX	2
21.	57444	TIE, CABLE BLACK NYLON 5 62L	1
22.	55511	WIRE, GROUND, 12 5"	1
23.	271184	NUT, 5/16-18 HEXKEPS	1
24.	57769	BULB, INDICATOR	3
25.	300334	LIGHT SWITCH ON/OFF PANEL MNT	1
26.	57547	SWITCH, SEAT	1
27.	160505	SCREW, 1/4-20X .38PHPNHMAGR2	2
28.	302257	GENERIC BATTERY 12V	1
29.	57551	ROD, BATTERY	1
30.	57552	ROD, BATTERY, TOP	1
31.	325232	NUT, WING 1/4-20 NYLON	1
32.	120854	SCREW, 1/4-20X 63 HHC GR2	2
33.	271172	NUT, 1/4-20 REGHEXKEPS	2
34.	302031	FUSE, 15 AMP SPADE TYPE	1
35	A	BATTERY ACID, 80 OZ	1

YY SPADE TYPE FUSES ARE INCLUDED WITH THE WIRE HARNES
 ^ CAN BE PURCHASED LOCALLY

SCHEMATIC DRAWING:

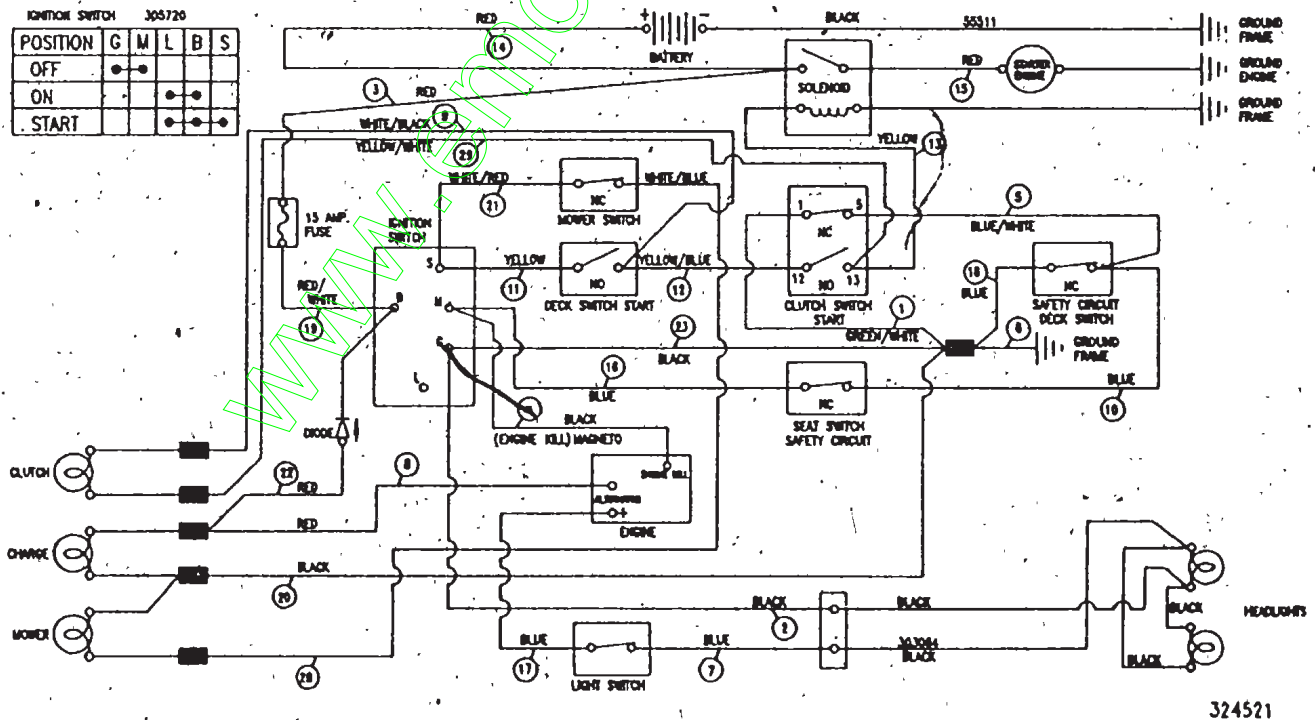

REPAIR PARTS

HYDROSTATIC PUMP

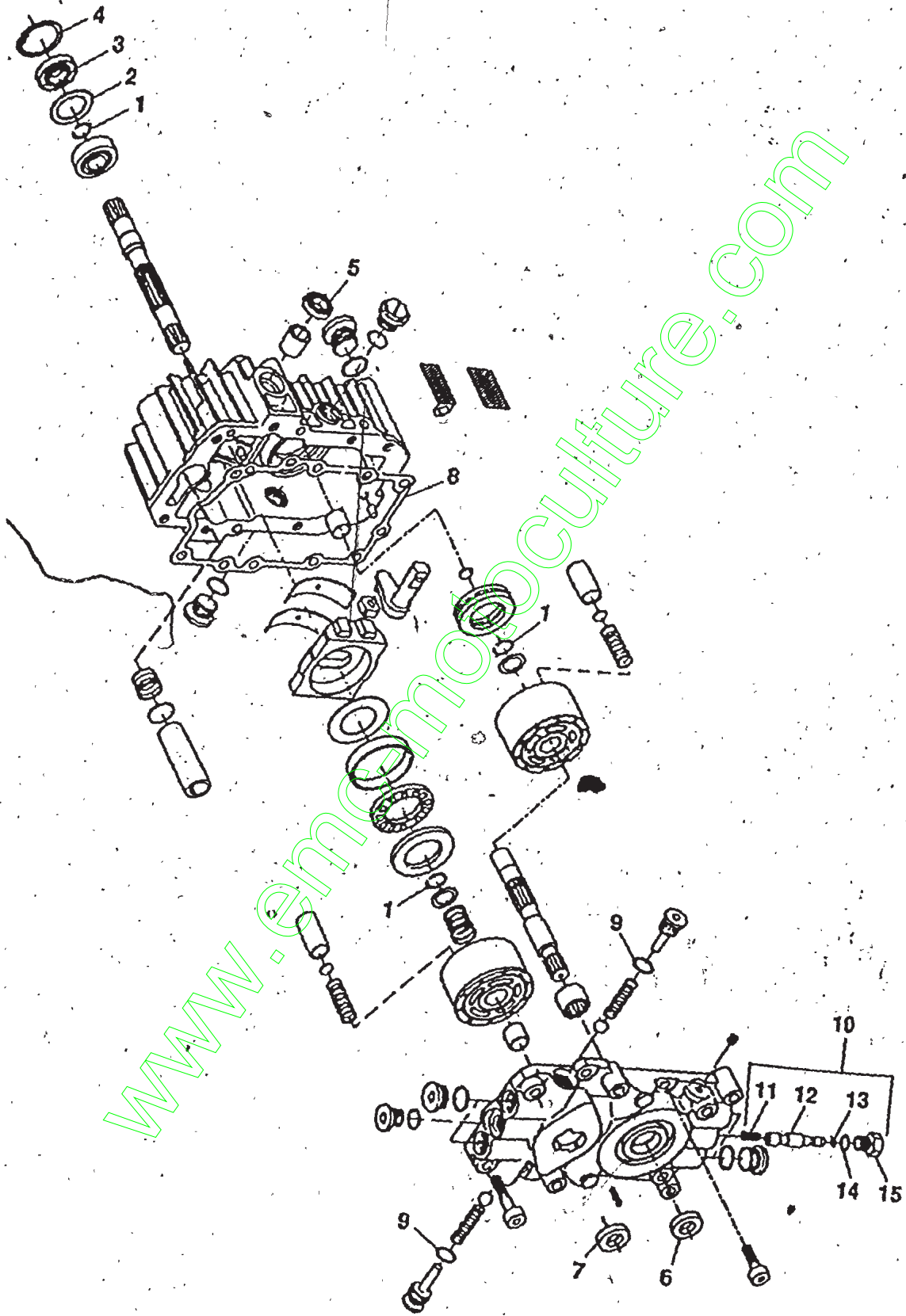

REPAIR PARTS

HYDROSTATIC PUMP

Key #	Part #	Description
	310227	HYDROSTATIC PUMP (COMPLETE)
	313306	OVERHAUL SEAL KIT (CONTAINS KEY NO.'S 1-9, 13 AND 14)
1		RING-RETAINING
2		SPACER
3		SEAL-LIP
4		RING-RETAINING
5		SEAL-LIP
6		SEAL-LIP
7		SEAL-LIP
8		GASKET-CENTER SECTION
9		O-RING
10	313305	BY-PASS VALVE KIT- COMPLETE (INCL. KEY NO.'S 11-15)
11		SPRING-HELICAL COMP
12		BY-PASS SPOOL
13		O-RING
14		O-RING
15		PLUG-BY-PASS

www.emc-motoculture.com

REPAIR PARTS

HYDROSTATIC TRANSAXLE

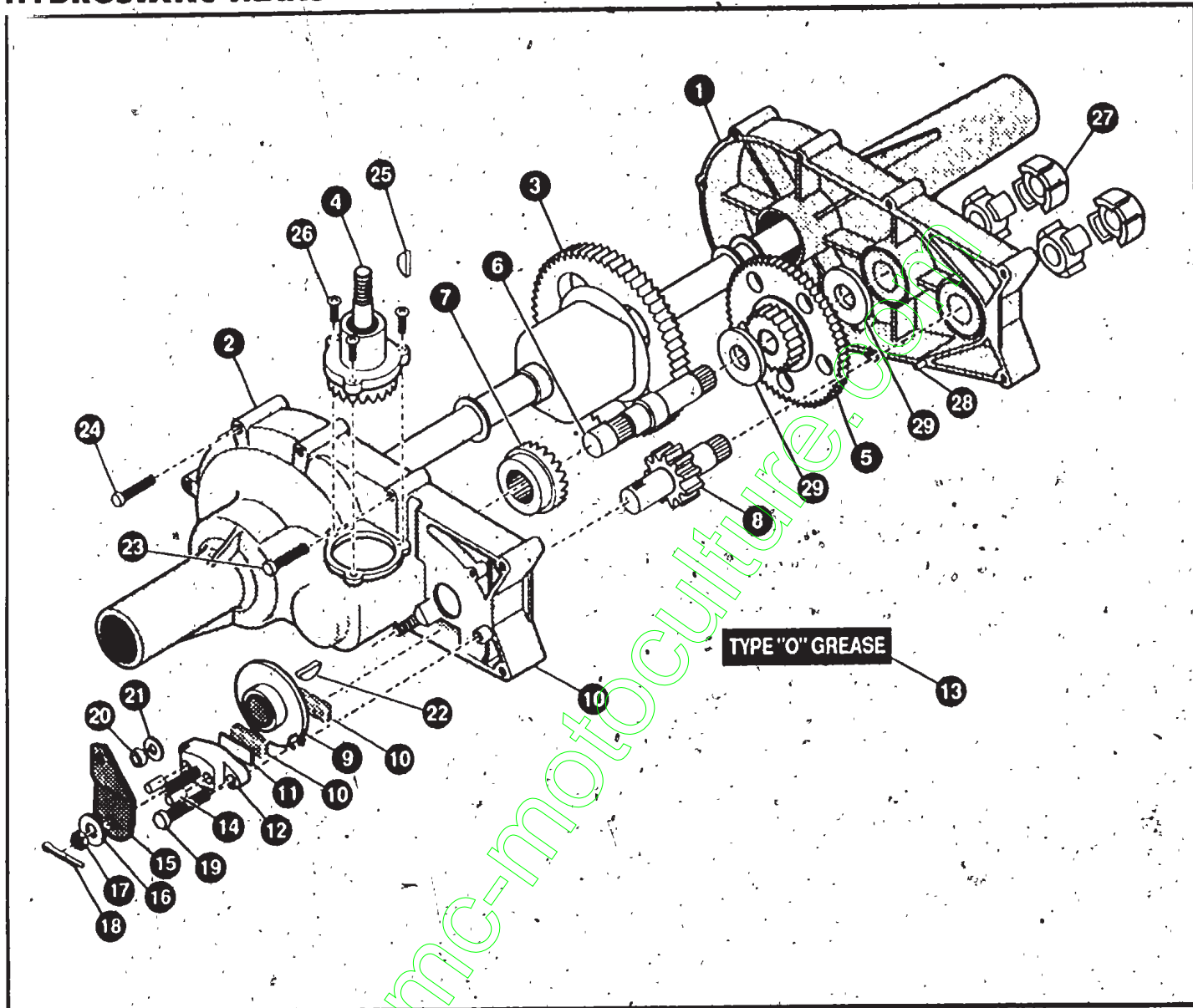

- 1 HOUSING HALF, LH
- 2 HOUSING HALF, RH
- 3 GEAR, DIFFERENTIAL
- 4 SHAFT, INPUT
- 5 GEAR
- 6 SHAFT, DRIVE
- 7 GEAR, DRIVE PINION
- 8 SHAFT, PINION
- 9 DISC, BRAKE
- 10 PUCK, BRAKE
- 11 PLATE, PUCK
- 12 BRAKE, YOKE
- 13 TYPE "O" GREASE
- 14 PIN, BRAKE ACTUATING
- 15 ARM, BRAKE ACTUATOR

- 16. WASHER, FLAT
- 17. NUT, CASTLE
- 18. PIN, COTTER
- 19. BOLT, HEX W/PATCH
- 20. NUT, HEX
- 21. WASHER, SPRING LOCK
- 22. KEY, HI-PRO
- 23. BOLT, HEX SELF-TAP
- 24. BOLT, HEX SELF-TAP
- 25. KEY, HI-PRO
- 26. SCREW, HEX W/PATCH
- 27. COUPLING
- 28. PIN, ROLL
- 29. WASHER, FLAT

ACCESSORIES

Contact the dealer where your tractor was purchased for the available accessories. If you are unable to contact the dealer, write to the address on the front cover of this manual.

Model	Description	Rear Engine Rider
5708-16	Bagger - Fits 32" Side Discharge	
5708-17	Bagger - Fits 36" Side Discharge & 30" Top Discharge	
5709-02	Front Weight Box - holds 35 lbs.	
5648-16	Lawn Sweeper w/dump Release	
5714-00	Mulching Kit - 30" Top Discharge	

Model	Description	Lawn Tractor
5708-22	Bagger - Fits 30" Side Discharge	
5708-13	Bagger - Fits 36", 38", 39" & 45" Side Discharge	
5705-04	36" Two-Stage Snowblower - Fits 36", 38", 39", & 45" Side Discharge	
5661-06	42" Snowblade - Fits 36", 38", 39", & 45"	
5592-00	Tire Chains - 18" x 6.50"	
5585-00	Tire Chains - 18" x 9.50" & 20" x 8"	
5672-01	Wheel Weights - Front - 1 pr. w/mtg. hdw. - Fits 15" tires	
5673-02	Wheel Weights - Rear - 1 pr. w/mtg. hdw. - Fits 18" & 20" tires	
5709-03	Front Weights - Fits 30" & 32" Side Discharge	
5648-16	Lawn Sweeper w/dump Release	
5714-00	Mulching Kit - 30" Top Discharge	

Model	Description	Garden Tractor - Light Ground Engaging
5708-13	Bagger - Fits 36", 38", 39", & 45" Side Discharge	
5705-04	36" Two-Stage Snowblower - Fits 36", 38", 39", & 45"	
5661-06	42" Snowblade - Fits 36", 38", 39", & 45"	
5672-01	Wheel Weights - Front 1 pr. w/mtg. hdw. - Fits 15" tires	
5673-02	Wheel Weights - Rear - 1 pr. w/mtg. hdw. - Fits 18" & 20" tires	
5648-16	Lawn Sweeper w/dump Release	
5667-02	Sleeve Hitch - w/lift bar - Fits 45"	
5668-01	Adaptor (sleeve hitch) for use w/23" tires	
5706-00	Tire Chains - 20" x 10"	
5671-00	Tire Chains - 23" x 9.50"	
5672-02	Wheel Weights - Front - 1 pr. w/mtg. hdw. Fits 16" tires	
5673-00	Wheel Weights - Rear - 1 pr. w/mtg. hdw. Fits 23" tires	
5674-01	10" One Bottom Moldboard Plow	
5675-01	Cultivator - 7 row - Adj. 6" - 42" width	
5676-01	Disc Harrow - 8" & 11" disc - Adj. width & disc angle	
5677-02	Tiller - 5 H.P. Self-Powered - 28" width	

Model	Description	Four Wheel Steer
5708-14	Bagger - Fits 40" & 46" Side Discharge	
5705-05	42" One-Stage Snowblower - Fits 40" & 46"	
5661-07	48" Snowblade - Fits 40" & 46"	
5709-04	Rear Weight Box for 40" & 46"	
5648-16	Lawn Sweeper w/dump Release	
5706-00	Tire Chains - 20" x 10"	
5671-00	Tire Chains - 23" x 9.50"	
5672-02	Wheel Weights - Front - 1 pr. w/mtg. hdw. Fits 16" tires	
5673-00	Wheel Weights - Rear - 1 pr. w/mtg. hdw. Fits 23" tires	
5672-01	Wheel Weights - Front - 1 pr. w/mtg. hdw. Fits 15" tires	
5673-02	Wheel Weights - Rear - 1 pr. w/mtg. hdw. Fits 18" & 20" tires	

Model	Description	Two Wheel Steer Garden Tractor
5667-04	Sleeve Hitch - w/lift bar - Fits 46"	
5674-01	10" One Bottom Moldboard Plow	
5675-01	Cultivator - 7 row - Adj. 6" - 42" width	
5676-01	Disc Harrow 8" & 11" Disc - Adj. width & disc angle	
5677-02	Tiller 5 H.P. Self-Powered - 28" width	
5648-16	Lawn Sweeper w/dump Release	

*Requires a sleeve hitch