

287707-0227-01-9502024A

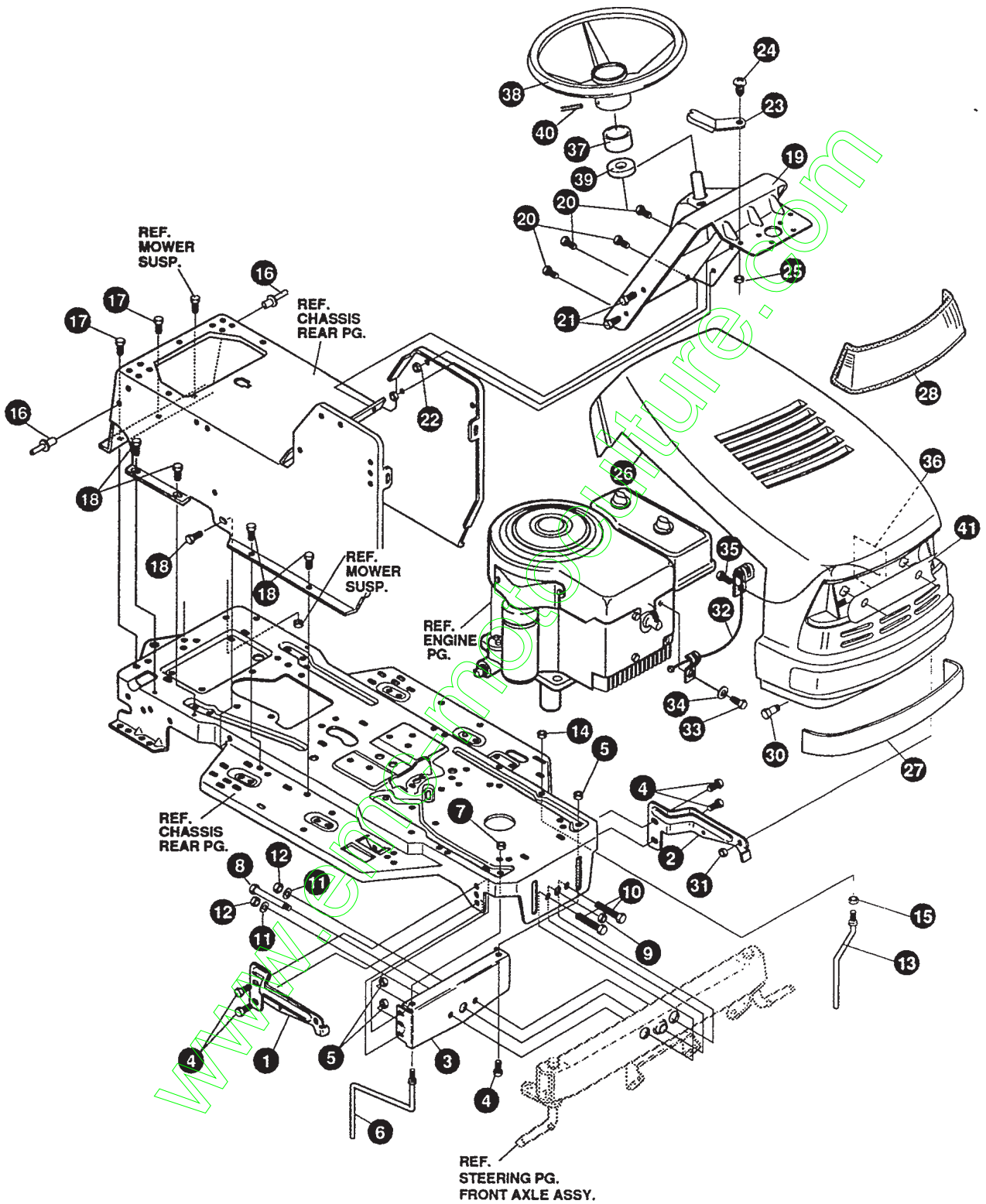

F3560-810
14.5HP/40"



NOTE: ALWAYS USE ORIGINAL EQUIPMENT PARTS.
 Use of service/replacement parts other than original equipment parts may void your warranty.

ALL UNNUMBERED ITEMS ARE INTERCHANGEABLE WITH OPPOSITE SIDE

325864 C

KEY#	PART#	DESCRIPTION	QTY
1	326568-853	BRACKET, GRILLE, RH	1
2	326569-853	BRACKET, GRILLE, LH	1
3	313541-853	BRACKET, FRONT AXLE	1
4	56030	SCREW, 5/16-18 X .75 WDFLLK	5
5	55273	NUT, 5/16-18 WDFLLKLRG, WHIZ	5
6	300440	GUIDE, BELT, RIDER	1
7	1498	NUT, 5/16-18 REGHEXCTRLK	1
8	308207	BOLT, .625 X 2.18 HSH, 1/2-13	1
9	309008	NUT, 1/2-13 HEXJAM CTRLK	1
10	180138	SCREW, 3/8-16 X 3.00 HHC	2
11	2483	WASHER, .39 ID X 1.25 D X .07 BELLVIL	2
12	1499	NUT, 3/8-16 REGHXCTRLK	2
13	300635	GUIDE, BELT SHORT, 15" WHEEL	1
14	124824	NUT, 5/16-18 HEXJAM	1
15	271190	NUT, 3/8-16 HEXKEPS	1
16	46763	RIVET, POP .187 DIA X .450 LONG	3
17	35497	SCREW, 5/16-18 X .50 WAHTAP	2
18	995346	SCREW, 1/4-20 X .50 WAHTAP	10
19	309447-860	DASH, STEEL, LF, SUSP	1
20	995346	SCREW, 1/4-20 X .50 WAHTAP	4
21	44811	SCREW, 1/4-20 X .75 WAHTAP	4
22	50352	NUT, 1/4-20 WDFLLK TOPLOCK	4
23	313021-853	GUIDE, HOOD, SF & LF, H13, H14, H15	2
25	51335	NUT, 1/4-20 WDFLWHIZ-LK	2
26	304188	HOOD, NOMA, LARGE, H-15	1
27	319986	DECAL, TAPE, H15, 8MIL, VINYL	1
28	302670	LENS, HEADLAMP, DYNA, HOODS	1
30	56676	BOLT, .375 X .580 HSH, 5/16-18	2
31	1498	NUT, 5/16-18 REGHEXCTRLK	2
32	310749	LANYARD, HOOD, 9.16 LONG, H14	1
33	180020	SCREW, 1/4-20 X .75 HHC	1
34	120380	WASHER, REGSPTLK .263 X .49 X .07	1
35	49050	SCREW, 1/4-10 X .75 PHPNTAP	1
36	301452	FOIL, HEAT REFLECTOR	1
37	311465	COVER, STEERING SHAFT	1
38	330848	STEERING WHEEL	1
39	301413	SPACER, STEERING SHAFT	1
40	456378	PIN, SPRING .250 DIA X 2.00 LONG	1
41	308492	FOIL, LENS, DYNA, HOOD REFLECTOR	1
	336709	PARTS MANUAL	1
	335154	OPERATOR'S MANUAL (ENGLISH)	1
	335155	OPERATOR'S MANUAL (FRENCH)	1
	335156	OPERATOR'S MANUAL (GERMAN)	1
	336721	OPERATOR'S MANUAL (SPANISH)	1

F3560-810

REPAIR PARTS

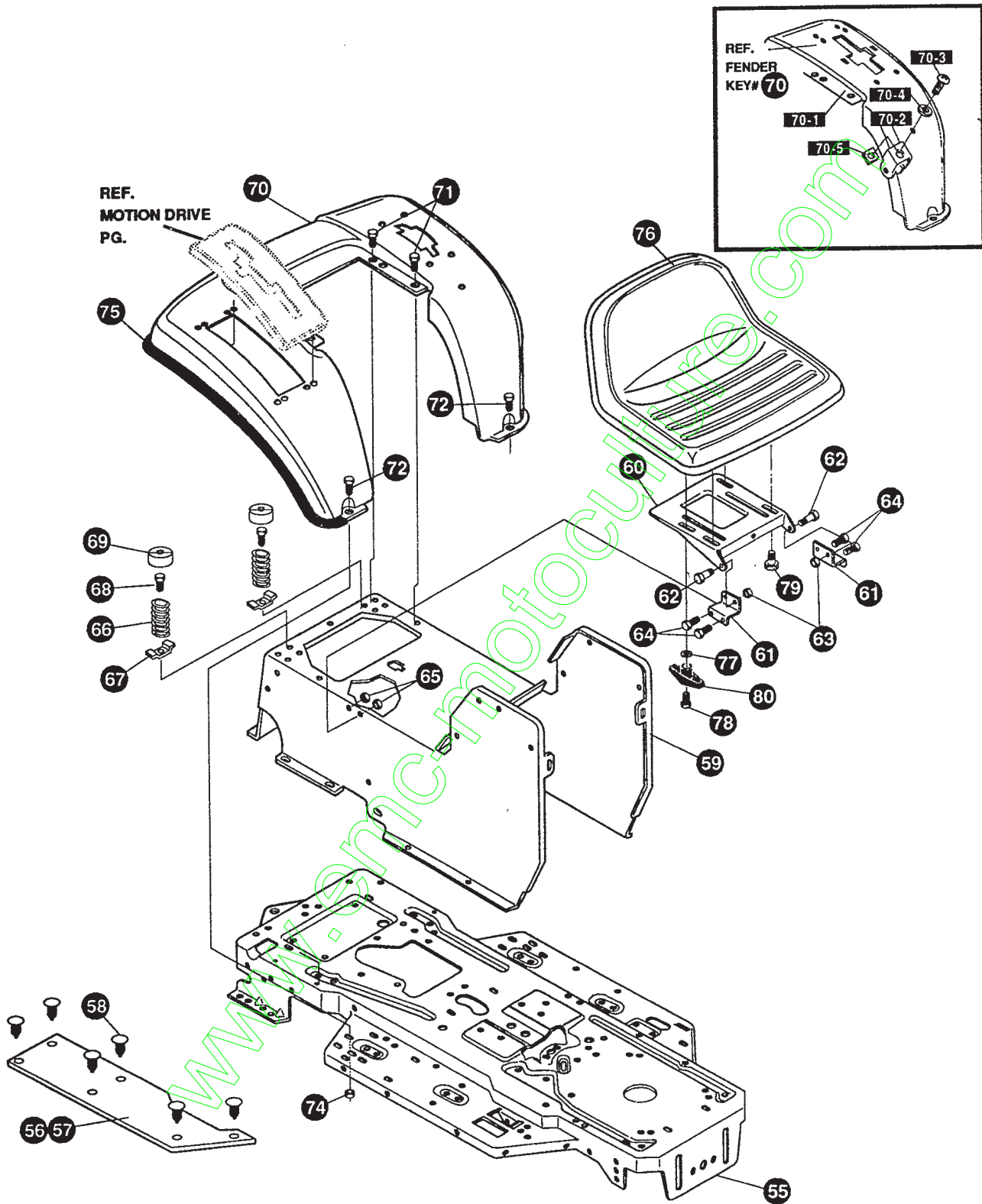

NOTE: ALWAYS USE ORIGINAL EQUIPMENT PARTS.
Use of service/replacement parts other than original equipment parts may void your warranty.

**ALL UNNUMBERED
ITEMS ARE INTERCHANGEABLE
WITH OPPOSITE SIDE**

332885 B

F3560-810

REAR CHASSIS & HOOD ASSEMBLY

KEY#	PART#	DESCRIPTION	QTY
55	335851-860	FRAME, LF, DRILLED, P920/F4360	1
56	310005	FOOT PAD, LH, 22.12 LONG, DYNA, F-5	1
57	310006	FOOT PAD, RH, 22.12 LONG, DYNA, F-5	1
58	309235	FASTENER, RATCHET, BLACK	12
59	308665-860	CONSOLE, H14-15, SOF	1
60	331535-853	PLATE, SEAT, F5, SF/LF QUICK	1
61	310660-853	BRACKET, F-5, SEAT SUPPORT	2
62	20507	BOLT, .437 X .156 HSH, 5/16-18	2
63	1498	NUT, 5/16-18 REGHEXCTRLK	2
64	48901	SCREW, 5/16-18 X .63 WAHHC	4
65	1498	NUT, 5/16-18 REGHEXCTRLK	4
66	57153	SPRING, SEAT, 2.63 LONG, 1.49 OD, BLACK	2
67	1341	CLAMP, SPRING 1.17 ID	2
68	44811	SCREW, 1/4-20 X .75 WAHTAP	2
69	56907	COVER, SEAT SPRING, 1.5 ID X 1.0 LONG	2
70	*	ASSEMBLY, FENDER, F5, LF, SOF, SUSP	1
70-1	332185	FENDER, F5, SUS, LF, SOF	1
70-2	9239	CLEVIS	1
70-3	439455	SCREW, 5/16-18 X .56 PHPNMA	1
70-4	301551	WASHER, .344 ID X 1.50 D X .09	1
70-5	120373	NUT, 5/16-18 SQUARE	1
71	995346	SCREW, 1/4-20 X .50 WAHTAP	4
72	126358	BOLT, 5/16-18 X 1.00 CARRLN	2
74	55273	NUT, 5/16-18 WDFLLKLRG, WHIZ	2
75	55023	TRIM, STRIP, BLACK—SMALL, W/ ADH	77.5
76	331528	SEAT, MICHIGAN LF QUICK	1
77	120393	WASHER, FLAT .344 X .69 X .065	1
78	180079	SCREW, 5/16-18 X 1.00 HHC	1
79	331637	BOLT, .500 X .10 HSH, 5/16-18	2
80	13527	KNOB, T 3.00 WD PLAS BLACK	1

* ORDER INDIVIDUAL PARTS - ASSEMBLY NOT AVAILABLE

F3560-810

REPAIR PARTS

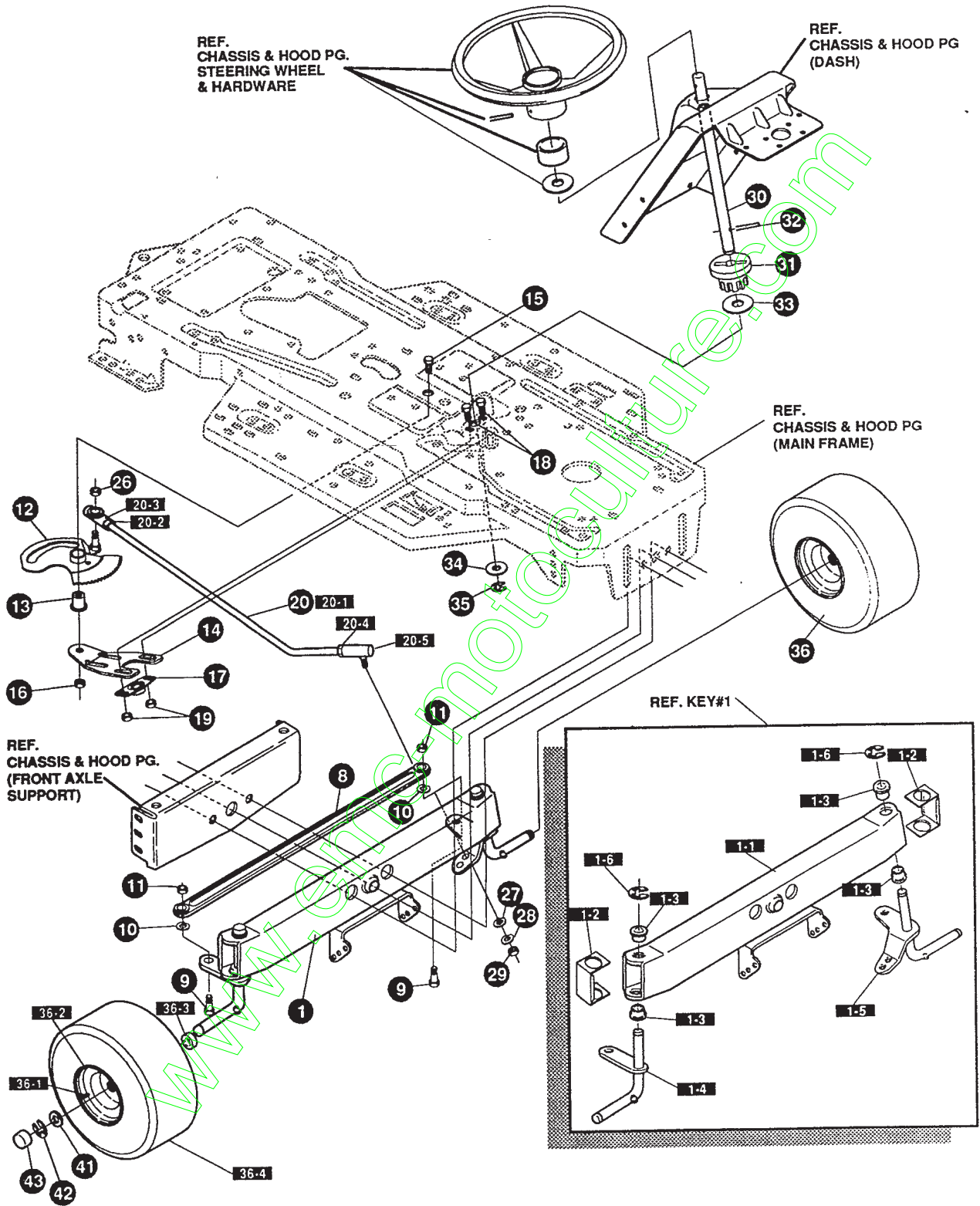

NOTE: ALWAYS USE ORIGINAL EQUIPMENT PARTS.
 Use of service/replacement parts other than original equipment parts may void your warranty.

**ALL UNNUMBERED
 ITEMS ARE INTERCHANGEABLE
 WITH OPPOSITE SIDE**

326803 E

KEY#	PART#	DESCRIPTION	QTY
1	*	ASSEMBLY, AXLE FRONT, 4WS, SUSP	1
1-1	310170	ASSEMBLY, FRONT AXLE, SUSPENDED	1
1-2	53373-853	AXLE COVER	2
1-3	52407	SPINDLE BEARING	4
1-4	302926	ASSEMBLY, SPINDLE, RH	1
1-5	315886	ASSEMBLY, SPINDLE, LH	1
1-6	36625	RING, RETEX .57 X .05 TRU 5133-75	2
8	304590	TIE ROD ASSEMBLY, 19.81 LONG W-SECTION	1
9	180128	SCREW, 3/8-16 X 1.75 HHC	2
10	120382	WASHER, REGSPTLK .393 X .68 X .10	2
11	120377	NUT, 3/8-16 REGHX	2
12	326889	ASSEMBLY, SECTOR GEAR, BLACK	1
13	313629	BEARING, SLEEVE	1
14	313671-853	SUPPORT, SECTOR GEAR, 4WS, LF	1
15	315196	SCREW, 1/2-20 X 3.00 HHC	1
16	274654	NUT, 1/2-20 REGHXCTRLK	1
17	302498	BEARING, SFAL .500 IDX) ODX .75	1
18	323731	SCREW, 5/16-24 X .75 (TO 30-35 FT#)	2
19	71100	NUT, 5/16-24 HEXWDFLLK	2
20	328583	ASSEMBLY, DRAG LINK, 4WS, HYDRO, LF	1
20-1	321449	DRAG LINK, .625 DIA FOR 4WS, LF	1
20-2	124925	NUT, 3/8-24 REGHEXJAM	1
20-3	304260	BALL JOINT, RH, 3/8-24	1
20-4	272123	NUT, 7/16-20 HXJAM	1
20-5	302865	BALL JOINT, 7/16-20	1
26	1499	NUT, 3/8-16 REGHXCTRLK	1
27	120396	WASHER, FLAT .531 X 1.06 X .095	2
28	120383	WASHER, REGSPTLK .459 X .78 X .12	1
29	271506	NUT, 7/16-20 REGHX	1
30	313699	SHAFT, STEERING, 4WS, LF	1
31	302314	PINION, STEERING	1
32	302524	PIN, DOWEL, STEER, ERO LT	1
33	315194	WASHER, FLAT .51 X 1.38 X .043	1
34	2968	WASHER, FLAT .504 X .75 X .059	1
35	20864	RING, RET E .39 X .04 TRU 5133-50	1
36	*	TIRE & RIM, PU 15 X 6.0 X 6	2
36-1	24167	VALVE STEM	
36-2	321516	RIM, WHEEL	
36-3	314416	BEARING, FLANGE	
36-4	316702	TIRE, 15 X 6 X 6	
41	642	WASHER, FLAT .75 5X 1.31 X .075	4
42	36625	RING, RETEX .57 X.05 TRU 5133-75	2
43	40394	HUB CAP, 1.500 ID X 7/8 LONG	2

* ORDER INDIVIDUAL PARTS - ASSEMBLY NOT AVAILABLE

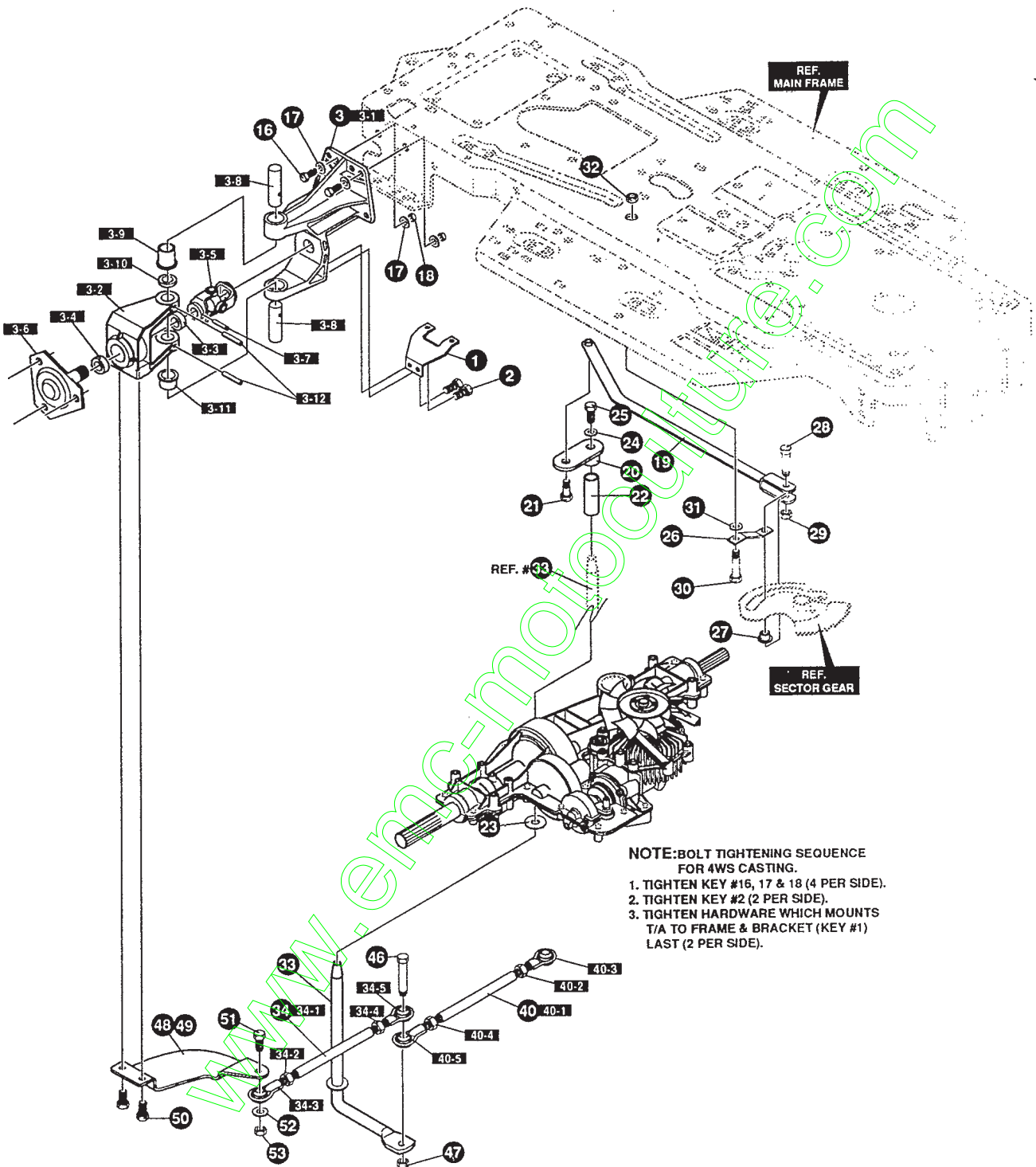

NOTE: BOLT TIGHTENING SEQUENCE FOR 4WS CASTING.
 1. TIGHTEN KEY #16, 17 & 18 (4 PER SIDE).
 2. TIGHTEN KEY #2 (2 PER SIDE).
 3. TIGHTEN HARDWARE WHICH MOUNTS T/A TO FRAME & BRACKET (KEY #1) LAST (2 PER SIDE).

NOTE: ALWAYS USE ORIGINAL EQUIPMENT PARTS.
 Use of service/replacement parts other than original equipment parts may void your warranty.

ALL UNNUMBERED ITEMS ARE INTERCHANGEABLE WITH OPPOSITE SIDE

334507 C

F3560-810

REAR STEERING ASSEMBLY

KEY#	PART#	DESCRIPTION	QTY
1	313645-853	BRACKET, X-AXLE MTG, 4WS, HYDRO	2
2	35498	SCREW, 5/16-18 X .75 WAHTAP	4
3	324359	U-JOINT, 4-WS, HEAVY DUTY	2
3-1	314267	BRACKET, STEERING, PIVOT DRILLED	1
3-2	315267	BRACKET, STEERING, PIVOT 6204 BEARING	1
3-3	12325	BEARING, BALL 6203-2AA-3/4	1
3-4	315268	BEARING, BALL 6204-2AA -7/8	1
3-5	320531	U-JOINT ASSEMBLY W/ZERK (LONG)	1
3-6	315264-853	HUB ASSEMBLY HEAVY	1
3-7	36311	PIN, GROOVED .250 DIA X 1.50 LONG	1
3-8	12289	PIN, STEERING HINGE	2
3-9	*	NON-SERVICEABLE PART (ORDER PART#324578) ..	1
3-10	21682	WASHER, FLAT .765 X 1.25 X .042	1
3-11	*	NON-SERVICEABLE PART (ORDER PART#324578) ..	1
3-12	456722	PIN, SPRING .250 DIA X 1.50 LONG	2
16	180079	SCREW, 5/16-18 X 1.00 HHC	6
17	120393	WASHER, FLAT .344 X .69 X .065	14
18	1498	NUT, 5/16-18 REGHXCTRLK	8
19	336148	BAR, DRAGLINK, LF, 4WS (D-EHYD)	1
20	308719	PIVOT, STEERING	1
21	12319	BOLT, .562 X .340 HSSH, 3/8-24	1
22	304115	SPACER, STEERING SHAFT	1
23	25177	WASHER, FLAT .765 X 1.19 X .048	1
24	45602	WASHER, FLAT .393 X .87 X .119	1
25	421051	SCREW, 5/16-24 X 1.00 HHC	1
26	302594	FOLLOWER, ROLLER	1
27	304116	CAM YOKE ROLLER	1
28	304122	BOLT, .625 X 1.175 HSSH	1
29	274654	NUT, 1/2-20 REGHXCTRLK	1
30	324638	BOLT, .265 X .980 HSSH, 3/8-24	1
31	996307	WASHER, FLAT .391 X 1.00 X .209	1
32	412349	NUT, 3/8-24 HXCTRLK	1
33	308720	SHAFT, STEERING PIVOT (ZN)	1
34	323634	TIE ROD, ASSEMBLY, RH, EURO, 4WS & LF, STD	1
34-1	308447	ROD, TIE 1/2"D X 8.12 LONG	1
34-2	308399	NUT, 3/8-24, LH, THD REGHJAM	1
34-3	308384	BALL JOINT, LH, 3/8-24	1
34-4	124925	NUT, 3/8-24 REGHEXJAM	1
34-5	304260	BALL JOINT, RH, 3/8-24	1
40	323635	TIE ROD, ASSEMBLY, LH, EURO, 4WS & LF, STD	1
40-1	308446	ROD, TIE 1/2"D X 9.75 LONG	1
40-2	308399	NUT, 3/8-24, LH, THD REGHJAM	1
40-3	308384	BALL JOINT, LH, 3/8-24	1
40-4	124925	NUT, 3/8-24 REGHEXJAM	1
40-5	304260	BALL JOINT, RH, 3/8-24	1
46	181646	SCREW, 3/8-24 X 1.75 HHC	1
47	412349	NUT, 3/8-24 HXCTRLK	1
48	304120-853	ARM, REAR WHEEL, STEER, RH	1
49	304121-853	ARM, REAR WHEEL, STEER, LH	1
50	47792	SCREW, 3/8-16 X 1.00 WAHTAP, BLACK	4
51	181639	SCREW, 3/8-24 X 1.25 HHC	2
52	120382	WASHER, REGSPTLK.393 X .68 X .10	2
53	412349	NUT, 3/8-24 HXCTRLK	2

* NON-SERVICEABLE PART - ORDER PART#324578

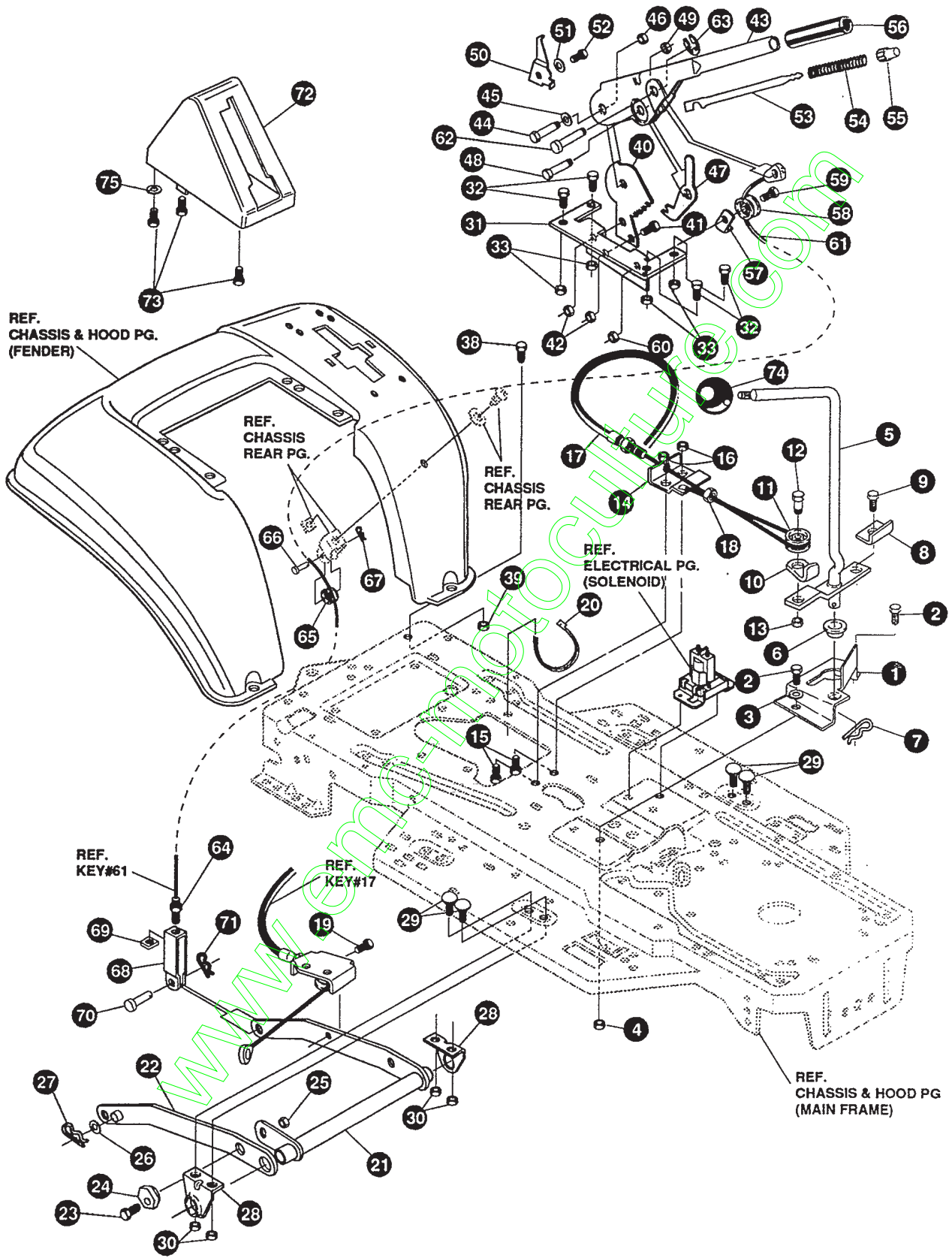

NOTE: ALWAYS USE ORIGINAL EQUIPMENT PARTS.
 Use of service/replacement parts other than original equipment parts may void your warranty.

ALL UNNUMBERED ITEMS ARE INTERCHANGEABLE WITH OPPOSITE SIDE

325815 F

F3560-810

MOWER SUSPENSION ASSEMBLY

KEY#	PART#	DESCRIPTION	QTY
1	320075-853	BRACKET, CLUTCH ENGAGE LEVER	1
2	180079	SCREW, 5/16-18 X 1.00 HHC	2
3	120393	WASHER, FLAT .344 X .69 X .065	2
4	1498	NUT, 5/16-18 REGHEXCTRLK	2
5	304791	ASSEMBLY, CLUTCH LEVER	1
6	50148	BEARING, FLANGE .503 ID X .63 OD X .50	1
7	8260	PIN, HAIR .091 DIA X 1.66 LONG	1
8	318341	BRACKET, SWITCH ENGAGE	1
9	35498	SCREW, 5/16-18 X .75 WAHTAP	1
10	1288	BRACKET, CABLE RETAINER	1
11	48306	PULLEY, METAL	1
12	58336	BOLT, .375 X .375 HSSH, 1/4-20	1
13	1502	NUT, 1/4-20 REGHEXCTRLK	1
14	300698-853	BRACKET, FRAME CABLE	1
15	180020	SCREW, 1/4-20 X .75 HHC	2
16	1502	NUT, 1/4-20 REGHEXCTRLK	2
17	301503	ASSEMBLY, CABLE, BLADE ENGAGE	1
18	120613	NUT, 1/4-28 HJAM	1
19	35498	SCREW, 5/16-18 X .75 WAHTAP	1
20	57444	TIE, CABLE BLACK NYLON, 5.62 LONG	1
21	300158-853	LIFT ASSEMBLY, LH	1
22	300169-853	LIFT ASSEMBLY, RH	1
23	180079	SCREW, 5/16-18 X 1.00 HHC	1
24	58247	NUT, ADJUST	1
25	1498	NUT, 5/16-18 REGHEXCTRLK	1
26	417098	WASHER, FLAT .531 X 1.06 X .063	2
27	8260	PIN, HAIR .091 DIA X 1.66 LONG	2
28	58248-853	BRACKET, REAR HANG SUSPENSION	2
29	57072	BOLT, 5/16-18 X .63 CARRLN	4
30	1498	NUT, 5/16-18 REGHEXCTRLK	4
31	313926	BRACKET, HEIGHT/ADJUST SUPPORT	1
32	180077	SCREW, 5/16-18 X .75 HHC	4
33	1498	NUT, 5/16-18 REGHEXCTRLK	4
38	180077	SCREW, 5/16-18 X .75 HHC	1
39	1498	NUT, 5/16-18 REGHEXCTRLK	1
40	301238	QUADRANT, HEIGHT ADJUST	1
41	180077	SCREW, 5/16-18 X .75 HHC	2
42	1498	NUT, 5/16-18 REGHEXCTRLK	2
43	322292-853	HANDLE,LIFT SHORT(30" S.F.)	1
44	300171	BOLT, .500 X .270 HSSH, 5/16-18	1
45	996418	WASHER, FLAT .506 X .75 X .024	1
46	44108	NUT, 5/16-18 HWDFLCTRLK	1
47	301239	PAWL, SQUARE	1
48	300171	BOLT, .500X .270 HSSH, 5/16-18	1
49	44108	NUT, 5/16-18 HWDFLCTRLK	1
50	9435	POINTER, HEIGHT ADJUST	1
51	138479	WASHER, EXLK .195 X .41 X .03	1
52	35287	SCREW, #8-32 X .38 HHWATAP	1
53	303027	ROD, ACTUATOR-SHORT	1
54	58326	SPRING, HEIGHT ADJUST	1
55	58325	KNOB, HEIGHT ADJUST, PUSH BUTTON	1
56	58329	GRIP, .750 OD, W/ HOLE BLACK	1
57	9149	BRACKET, CABLE RETAINER	1
58	48306	PULLEY, METAL	1
59	58336	BOLT, .375X .375 HSSH, 1/4-20	1
60	1502	NUT, 1/4-20 REGHEXCTRLK	1
61	314177	CABLE, LIFT, 22.92, F-5, 20 X 8-8	1
62	300310	PIN, CLEVIS .310 DIA+.475 LONG	1
63	300311	RING, RET E .31 X .25 TRU 5133-31	1
64	120375	NUT, 1/4-20 REGHEX	1
65	48306	PULLEY, METAL	1
66	300317	PIN, CLEVIS .375 DIA X .81 LONG	1
67	8260	PIN, HAIR .091 DIA X 1.66 LONG	1
68	9405	CLEVIS, LIFT CABLE	1
69	120372	NUT, 1/4-20 REGSQ	1
70	39522	PIN, CLEVIS .312 X .812	1
71	121222	PIN, COTTER .090 DIA X .75 LONG	1
72	333903	LIFT COVER, F5, LF, SF, BLACK	1
73	300340	SCREW, #10 X .75 HHPLAST, BLACK	3
74	55514	KNOB, ROUND 1.50 DIA, BLACK	1
75	120392	WASHER, FLAT .281 X .63 X .065	1

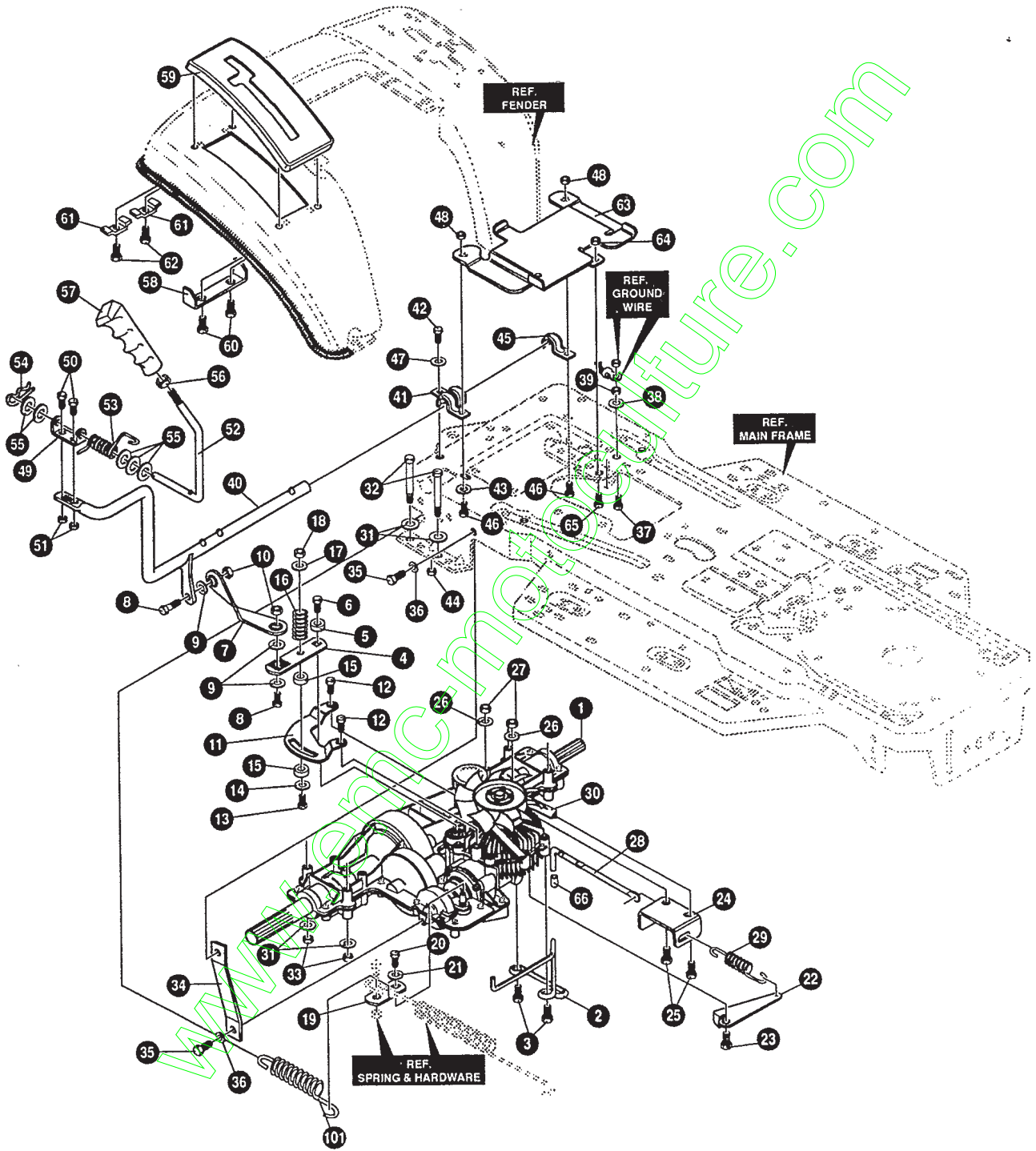

NOTE: ALWAYS USE ORIGINAL EQUIPMENT PARTS.
 Use of service/replacement parts other than original equipment parts may void your warranty.

ALL UNNUMBERED ITEMS ARE INTERCHANGEABLE WITH OPPOSITE SIDE

334511 B

KEY#	PART#	DESCRIPTION	QTY
1	*	TRANSAXLE, DANA, 4900, HYDRO, 4WS	1
2	334330	BELT GUIDE	1
3	35498	SCREW, 5/16-18 X .75 WAHTAP	1
4	334051	LEVER, TRANSAXLE SHIFT, LF	1
5	57157	WASHER, .750 X .250, SP-TRANSAXLE	1
6	56255	SCREW, 1/4-28 X .75 NYLHHC	1
7	333926	LINK, SHIFT, LF, DANA, HYDRO	1
8	180124	SCREW, 3/8-16 X 1.25 HHC	2
9	120394	WASHER, FLAT .406 X .81 X .065	3
10	1499	NUT, 3/8-16 REGHXCTRLK	2
11	334016-853	QUADRANT, SPEED CONTROL	1
12	44811	SCREW, 1/4-20 X .75 WAHTAP	2
13	180130	SCREW, 3/8-16 X 2.00 HHC	1
14	845	WASHER, FLAT .390 X 1.25 X .119	1
15	314944	WASHER, FRICTION, FABOND NF343	2
16	335689	SPRING-COMP .875 LONG X .0915 WIRE	1
17	120394	WASHER, FLAT .406 X .81 X .065	1
18	1499	NUT, 3/8-16 REGHXCTRLK	1
19	321845	BRACKET, LEVER S/F FND	1
20	56255	SCREW, 1/4-28 X .75 NYLHHC	1
21	57157	WASHER, .750 X .250 SP-TRANSAXLE	1
22	334122-853	LEVER, DUMP VALVE	1
23	334126	BOLT, .437 X .156 HHSHTAP, 5/16-18	1
24	334123-853	BRACKET, DUMP VALVE	1
25	180134	SCREW, 3/8-16 X 2.50 HHC	2
26	120394	WASHER, FLAT .406 X .81 X .065	2
27	1499	NUT, 3/8-16 REGHXCTRLK	2
28	334124	ROD, DUMP VALVE	1
29	326780	SPRING, 3/8 OD X 2.18 X .055 TENSION	1
30	335708	BELT, V 4L, 80.50, DANA, HYDRO, LF	1
31	120393	WASHER, FLAT .344 X .69 X .065	8
32	180113	SCREW, 5/16-18 X 3.00 HHC	4
33	1498	NUT, 5/16-18 REGHEXCTRLK	4
34	333959-853	BRACKET, STABILIZER	1
35	35498	SCREW, 5/16-18 X .75 WAHTAP	2
36	120638	WASHER, HVSPTLK .328 X .60 X .09	2
37	180077	SCREW, 5/16-18 X .75 HHC	1
38	138538	WASHER, REGINTLK.320 X .61 X .03	1
39	1498	NUT, 5/16-18 REGHEXCTRLK	1
40	336646-853	LEVER, SHIFT-LOWER, ASSEMBLY, LF	1
41	310347-853	CLIP- SHIFT LEVER, .625 ROD	2
42	180077	SCREW, 5/16-18 X .75 HHC	1
43	120393	WASHER, FLAT .344 X .69 X .065	1
44	1498	NUT, 5/16-18 REGHEXCTRLK	1
45	310347-853	CLIP- SHIFT LEVER, .625 ROD	1
46	180077	SCREW, 5/16-18 X .75 HHC	2
47	996416	WASHER, FLAT .391 X 1.00 X .125	1
48	1498	NUT, 5/16-18 REGHEXCTRLK	2
49	310356	BRACKET, PIVOT SHIFT LEVER	1
50	180020	SCREW, 1/4-20 X .75 HHC	2
51	1502	NUT, 1/4-20 REGHEXCTRLK	2
52	318452	LEVER, SHIFT, UPPER, SOF, 1/2-13	1
53	318451	SPRING, TORSION .56 X .95 X .095	1
54	8260	PIN, HAIR .091 DIA X1.66 LONG	1
55	2968	WASHER, FLAT .504 X .75 X .059	5
56	120238	NUT, 1/2-13 HEXJAM	1
57	306690	HANDLE, 1/2-13 MOLDED, BLACK	1
58	311257-853	BRACKET, COVER, F-5 FENDER SHIFT	1
59	314244	COVER, PLASTIC, LF, HYDRO, F-5	1
60	311331	SCREW, 1/4-15 X .44/.53 HILOHWA	2
61	1341	CLAMP, SPRING 1.17"ID	2
62	311331	SCREW, 1/4-15 X .44/.53 HILOHWA	2
63	335242-853	SHELF - BATTERY, LF	1
64	1502	NUT, 1/4-20 REGHEXCTRLK	1
65	180020	SCREW, 1/4-20 X .75 HHC	1
66	335980	CAP, DUMP VALVE ROD, .25 ID X .75 RED	1

* CONTACT YOUR NEAREST TRANSAXLE DEALER FOR PARTS & SERVICE

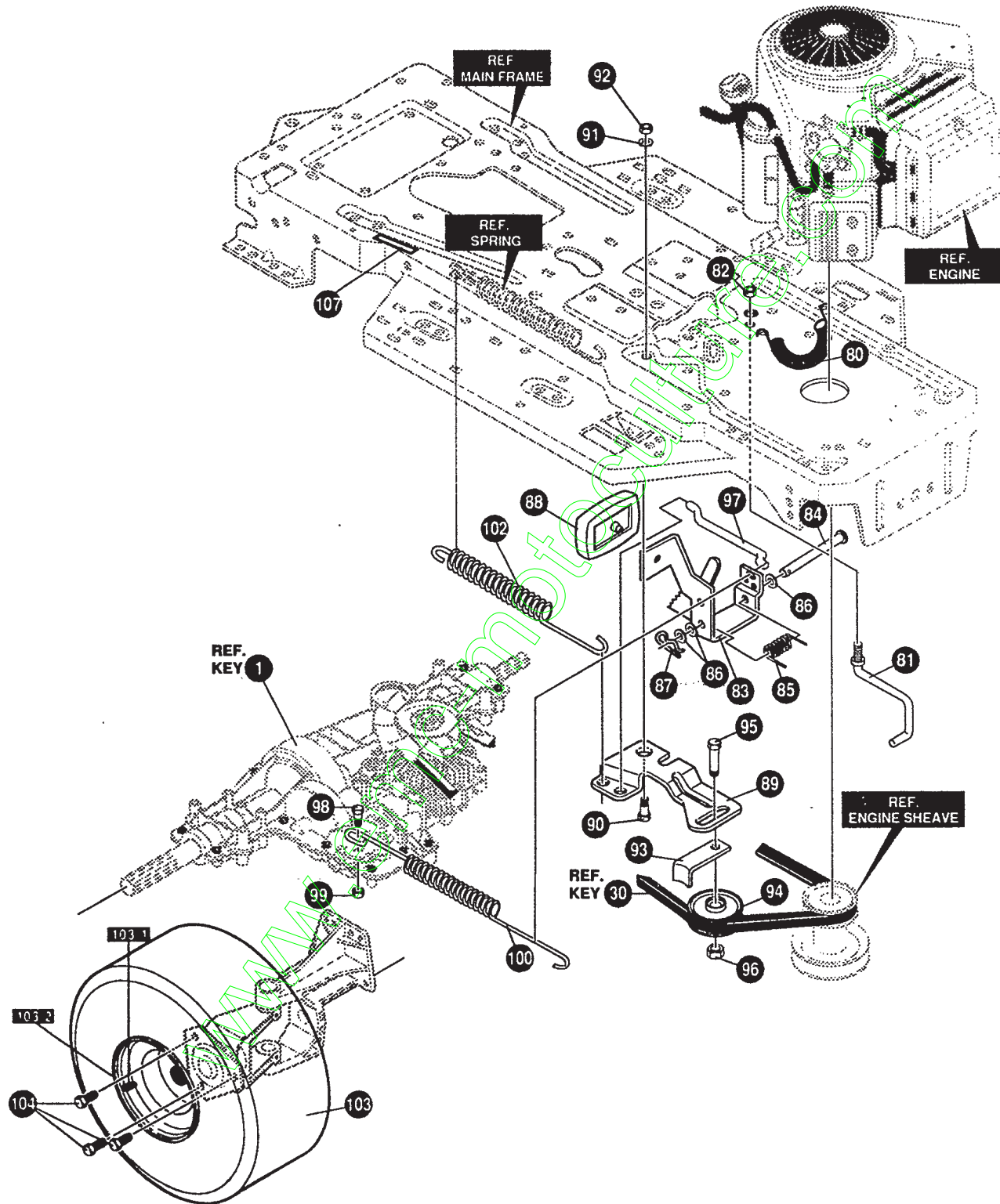

NOTE: ALWAYS USE ORIGINAL EQUIPMENT PARTS.
 Use of service/replacement parts other than original equipment parts may void your warranty.

ALL UNNUMBERED ITEMS ARE INTERCHANGEABLE WITH OPPOSITE SIDE

334511 B

KEY#	PART#	DESCRIPTION	QTY
80	321514	SPRING, DRAG LINK BIAS	1
81	304016	GUIDE, BELT, RH	1
82	1498	NUT, 5/16-18 REGHEXCTRLK	1
83	325942	PEDAL ASSEMBLY, BRAKE/CLUTCH, LF	1
84	319675	PIN, CLEVIS .500 D X 4.53 LONG	1
85	57847	SPRING, BRAKE PEDAL	1
86	2968	WASHER, FLAT .504 X .75 X .059	3
87	56180	PIN, HAIR .091 DIA X 1.62 LONG	1
88	48160	PAD, CLUTCH BRAKE, W/PRINTING	1
89	335656	ARM, IDLER TRACTION, LF	1
90	329989	BOLT, .625 X .135 HSH, 5/16-18	1
91	45602	WASHER, FLAT .333 X .87 X .119	1
92	1498	NUT, 5/16-18 REGHEXCTRLK	1
93	39659	RETAINER, BELT	1
94	35374	PULLEY, IDLER V4L, 3.06 X .62	1
95	45892	BOLT, 3/8-16 X 1.50 CARRSN	1
96	1499	NUT, 3/8-16 REGHXCTRLK	1
97	57204	ROD, CLUTCH 3.92"	1
98	326131	BOLT, .495 X .31 HSH, 5/16-18	1
99	1498	NUT, 5/16-18 REGHEXCTRLK	1
100	334175	SPRING, BRAKE, 25.88, LF, DANAHYD	1
101	334382	SPRING, .071 X .62 X 9.00	1
102	325123	SPRING, CLUTCH 16.01 X 750 X 6.88	1
103	*	TIRE & RIM, 20 X 10.00-8	2
103-1	24167	VALVE STEM	
103-2	316667	RIM, WHEEL	
103-3	319686	TIRE, 10 X 10 - 8	
104	181683	SCREW, 1/2-20 X .50 HHC	6
107	313039	DECAL, 4WS PATENT NO. 5048853	1

* ORDER INDIVIDUAL PARTS - ASSEMBLY NOT AVAILABLE

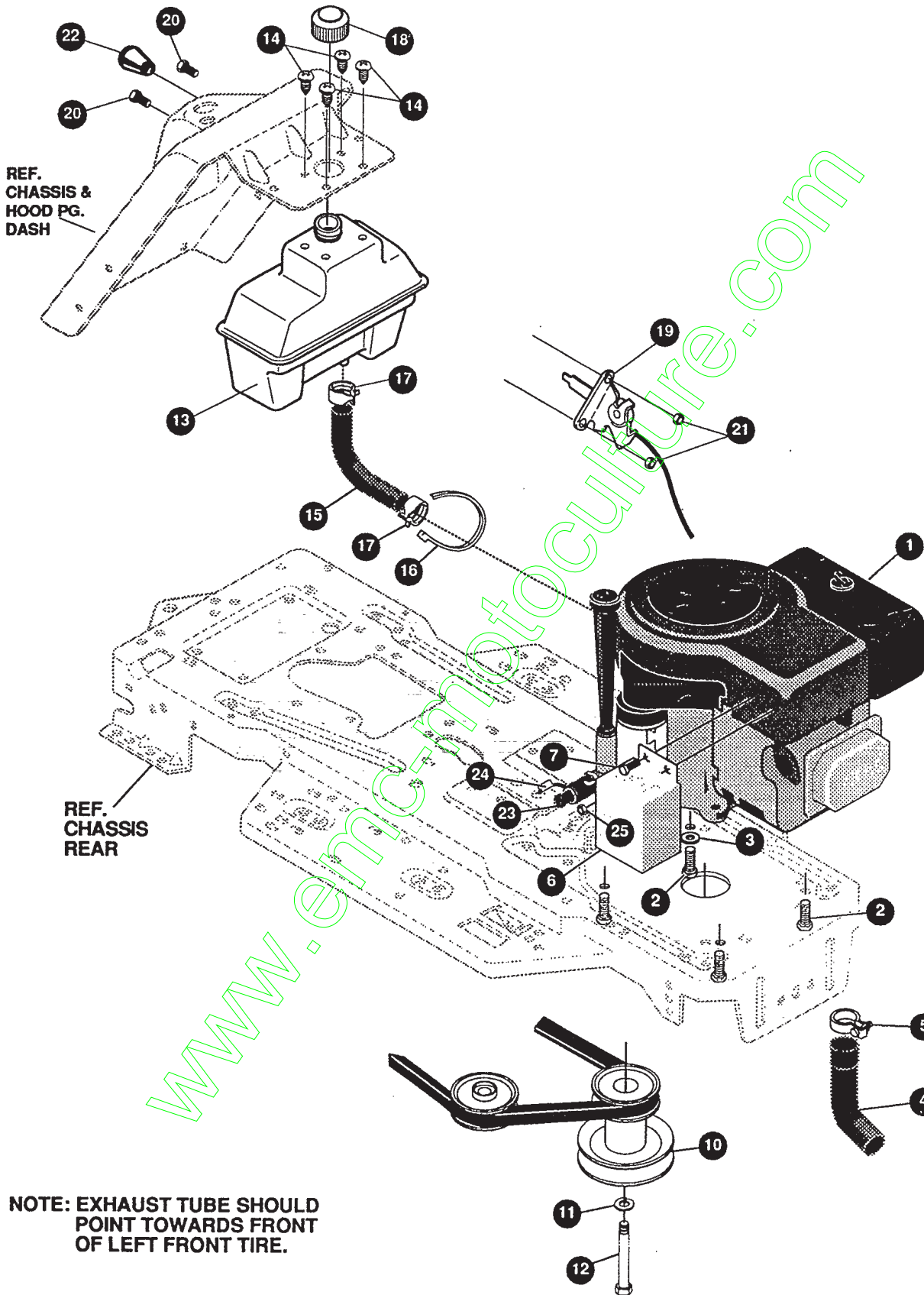

336357 A

KEY#	PART#	DESCRIPTION	QTY
1	*	ENGINE, 14.0HP, B&S, IC, OHV, DUAL CIRCUIT	1
2	50947	SCREW, 3/8-16 X 1.25 WAHHTAP	4
3	138489	WASHER, EXLK .384 X .69 X .04	1
4	327868	EXHAUST TUBE, 14HP, OHV, B&S, LF, H15	1
5	328024	CLAMP, EXHAUST 1.37 DIA	1
6	327785-853	HEAT SHIELD, 14HP, OHV, B/S	1
7	995346	SCREW, 1/4-20 X .50 WAHHTAP	3
10	335093	PULLEY, ENGINE 4.60 D X 4.0 LONG X 5.0D	1
11	120383	WASHER, REGSPTLK .459 X .78 X .12	1
12	433146	SCREW, 7/16-20 X 4.25 HHC, BLACK	1
13	314989	TANK, FUEL 1 GALLON, CLEAR	1
14	49050	SCREW, 1/4-10 X .75 PHPNTAP	4
15	50118	TUBING, .25 X .50 X BULK GAS LINE	13.5"
16	57444	TIE, CABLE BLACK NYLON, 5.62 LONG	1
17	47345	CLAMP, HOSE SCREW TYPE	2
18	46704	CAP, GAS 1-1/2-7 THD, BLACK	1
19	321273	CONTROL, THROTTLE, 12-12.5HP, LF	1
20	320553	SCREW, 10-24 X .63 PHPNMA CRSS	2
21	308459	NUT, #10-24 HXHDNYLK	2
22	50607	KNOB, ROUND THROTTLE, BLACK	1
23	325547	OIL DRAIN VALVE ASSEMBLY	1
24	327422	CAP, OIL DRAIN VALVE ASSEMBLY, YELLOW	1
25	124818	NUT, 1/4-20 REGHXJAM	1

* SEE ENGINE MANUAL

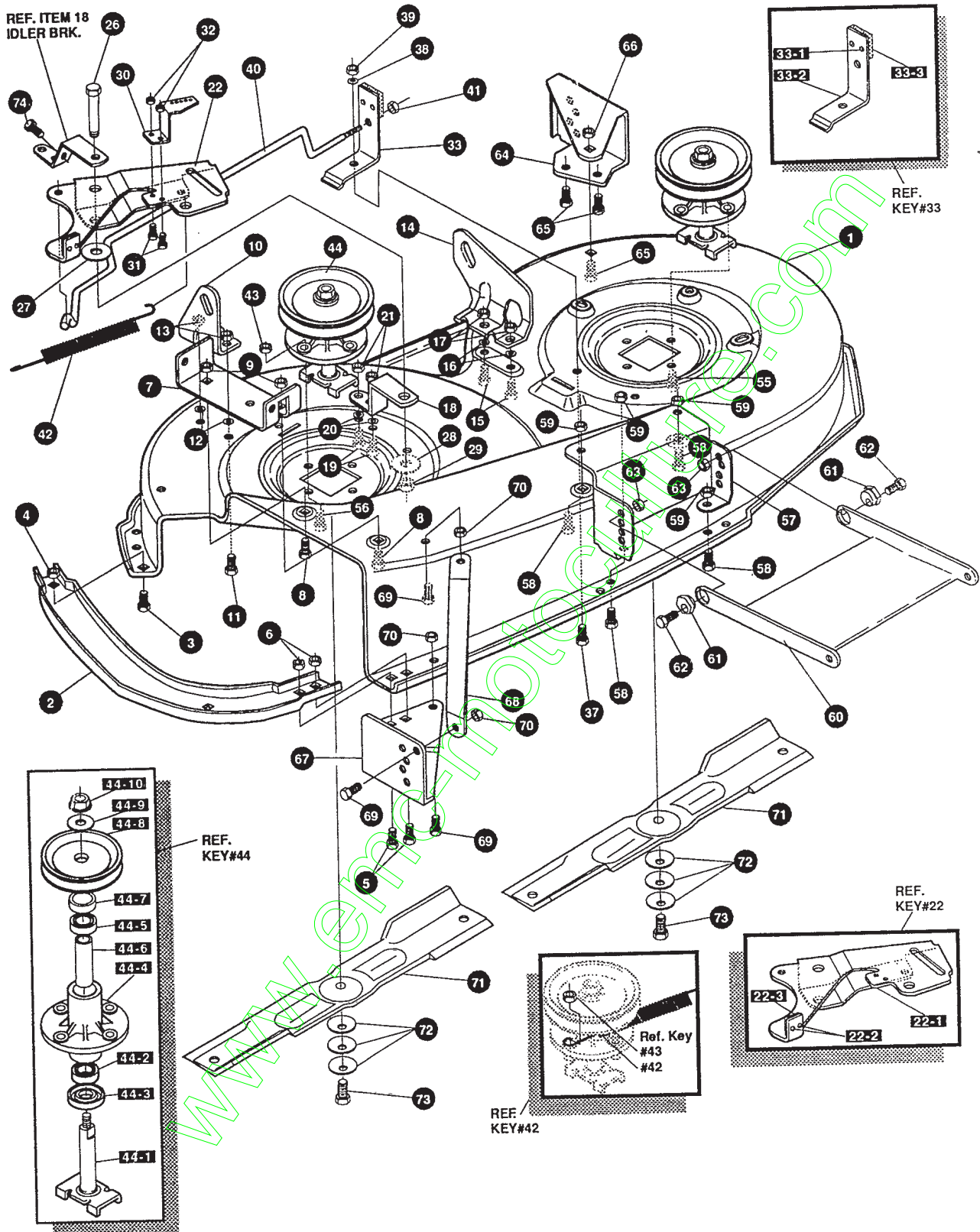

NOTE: ALWAYS USE ORIGINAL EQUIPMENT PARTS.
 Use of service/replacement parts other than original equipment parts may void your warranty.

**ALL UNNUMBERED
 ITEMS ARE INTERCHANGEABLE
 WITH OPPOSITE SIDE**

320109 H

F3560-810

PRE-PAINTED DECK ASSEMBLY

KEY#	PART#	DESCRIPTION	QTY
1	325103	40" DECK KIT	1
2	326480	TOE GUARD - MULCHER	1
3	180077	SCREW, 5/16-18 X .75 HHC	1
4	1498	NUT, 5/16-18 REGHEXCTRLK	1
5	180077	SCREW, 5/16-18 X .75 HHC	2
6	1498	NUT, 5/16-18 REGHEXCTRLK	2
7	317017	BRACKET CHUTE MOUNT	1
8	180077	SCREW, 5/16-18 X .75 HHC	2
9	1498	NUT, 5/16-18 REGHEXCTRLK	2
10	313929	BRACKET, RH, LIFT REAR	1
11	180077	SCREW, 5/16-18 X .75 HHC	2
12	120393	WASHER, FLAT .344 X .69 X .065	2
13	1498	NUT, 5/16-18 REGHEXCTRLK	2
14	310667	BRACKET, LH, LIFT REAR	1
15	180077	SCREW, 5/16-18 X .75 HHC	2
16	120393	WASHER, FLAT .344 X .69 X .065	2
17	1498	NUT, 5/16-18 REGHEXCTRLK	2
18	326893	BRACE, IDLER SUPPORT, 40", 43"	1
19	180077	SCREW, 5/16-18 X .75 HHC	2
20	120393	WASHER, FLAT .344 X .69 X .065	2
21	44108	NUT, 5/16-18 HWDFLCTRLK	2
22	320576	IDLER ARM ASSEMBLY	1
22-1	322116	ARM, IDLER, 40/43" DECK	1
22-2	41601	RIVET, OVSET .187 DIA X .50 LONG	2
22-3	306973	BRAKE PAD - HARD-NF343 (X-31)	1
26	304420	BOLT, .500 X 2.15 HSSH	1
27	996307	WASHER, FLAT .391 X 1.00 X .209	1
28	996416	WASHER, FLAT .391 X 1.00 X .125	2
29	45171	NUT, 3/8-16 HWDFL WHIZ-LOCK	1
30	326249	BRACKET, EXTENSION IDLER	1
31	180077	SCREW, 5/16-18 X .75 HHC	2
32	1498	NUT, 5/16-18 REGHEXCTRLK	2
33	321828	BLADE BRAKE ASSEMBLY	1
33-1	135624	RIVET, TRSET .185 DIA X .41 LONG	2
33-2	304119	BRAKE ARM	1
33-3	306973	BRAKE PAD - HARD-NF343 (X-31)	1
37	180077	SCREW, 5/16-18 X .75 HHC	1
38	120393	WASHER, FLAT .344 X .69 X .065	1
39	1498	NUT, 5/16-18 REGHEXCTRLK	1
40	302714	ROD, BRAKE	1
41	1502	NUT, 1/4-20 REGHEXCTRLK	1
42	35410	SPRING, .071 X .62 X 4.37	1
43	1498	NUT, 5/16-18 REGHEXCTRLK	1
44	56424	QUILL ASSEMBLY, 36/39/40/43 <i>36/39/40</i>	2
44-1	56425	SHAFT/SADDLE 36"	1
44-2	49562	BEARING, BALL 6203-2AA-C3 ARMORED	1
44-3	50616	DUST SHIELD	1
44-4	55547	QUILL CASTING (1046)	1
44-5	49562	BEARING, BALL 6203-2AA-C3 ARMORED	1
44-6	50818	SPACER, SLEEVE .669 X .88 X 3.797	1
44-7	51449	SPACER, SLEEVE .672 X .93 X .438	1
44-8	313898	PULLEY, 26/36" QUILL V5L	1
44-9	56365	WASHER, SPECIAL QUILL	1
44-10	1282	NUT, 7/16-20 WDFLLK	1
55	35498	SCREW, 5/16-18 X .75 WAHHTAP	7
56	300345	SCREW, 5/16-18 X 1.38 WAHHTAP	1
57	318445	BRACKET, 40", LF, FRONT DECK	1
58	180077	SCREW, 5/16-18 X .75 HHC	4
59	1498	NUT, 5/16-18 REGHEXCTRLK	4
60	58305	BRACKET, LINK DECK FRONT	1
61	58247	NUT, ADJUST	2
62	180079	SCREW, 5/16-18 X 1.00 HHC	2
63	1498	NUT, 5/16-18 REGHEXCTRLK	2
64	317041	BRACKET, GAGE WHEEL, LH	1
65	180077	SCREW, 5/16-18 X .75 HHC	3
66	1498	NUT, 5/16-18 REGHEXCTRLK	3
67	322464	BRACKET, GAGE WHEEL, RH, FRONT	1
68	314282	BRACKET, STABILIZER	1
69	180077	SCREW, 5/16-18 X .75 HHC	3
70	1498	NUT, 5/16-18 REGHEXCTRLK	3
71	313316	BLADE, 40", STD-LIFT, 20.32 <i>20.32</i>	2
72	2483	WASHER, .39 ID X 1.25 D X .07 BELLVIL	6
73	39573	SCREW, 3/8-24 X 1.00 NYLHHC	2
74	308231	SCREW, 1/4-20 X 1.25 HHWATAP	1

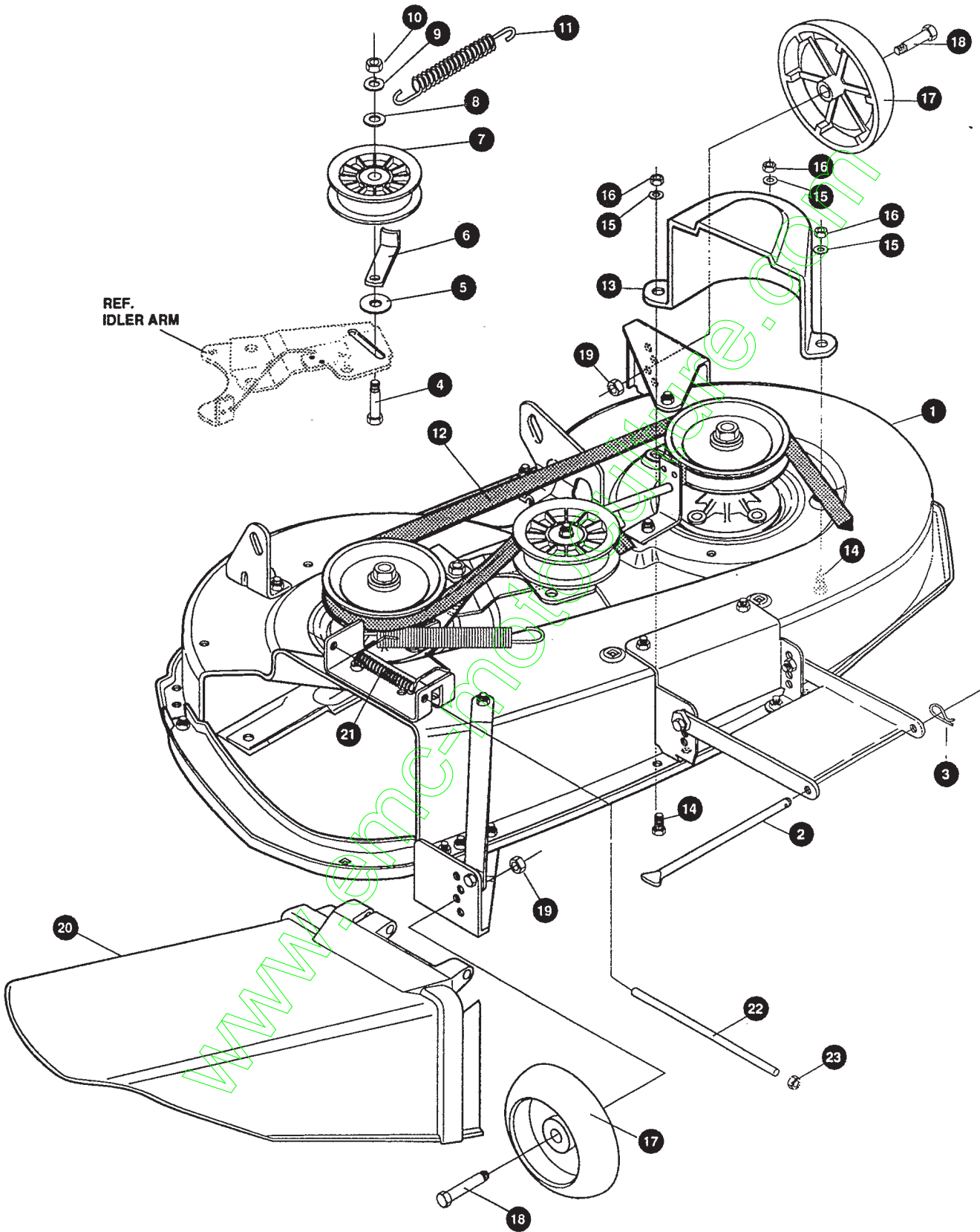

NOTE: ALWAYS USE ORIGINAL EQUIPMENT PARTS.
 Use of service/replacement parts other than original
 equipment parts may void your warranty.

**ALL UNNUMBERED
 ITEMS ARE INTERCHANGEABLE
 WITH OPPOSITE SIDE**

325682 B

KEY#	PART#	DESCRIPTION	QTY
1	329035	ASSEMBLY, 40", SUSPENDED DECK, EXPORT	1
2	58306	ROD, DECK HITCH	1
3	8260	PIN, HAIR .091 DIA X 1.66 LONG	1
4	57325	BOLT, 3/8-16 X 2.00 CARRSN	1
5	25210	WASHER, FLAT .386 X 1.25 X .09	1
6	1346	RETAINER, BELT	1
7	310326	PULLEY, IDLER BFF, 4.00 WIDE FL	1
8	996307	WASHER, FLAT .391 X 1.00 X .209	1
9	120382	WASHER, REGSPTLK .393 X .68 X .10	1
10	120377	NUT, 3/8-16 REGHX	1
11	300473	SPRING, TENSION 7.52 LONG+17 LB/IN	1
12	319005	BELT, V 5L, 81.00-DECK, 40", LF	1
13	328257	GUARD, BELT, (LH) PLASTIC	1
14	180077	SCREW, 5/16-18 X .75 HHC	3
15	120393	WASHER, FLAT .344 X .69 X .065	3
16	1498	NUT, 5/16-18 REGHEXCTRLK	3
17	302611	GAUGE WHEEL, EURO 6.00 OD X 1.38 WD	2
18	23763	BOLT, .500 X 1.390 HSH, 3/8-16	2
19	1499	NUT, 3/8-16 REGHXCTRLK	2
20	304422	CHUTE DEFLECTOR, 40", 42" & 43"	1
21	314975	SPRING, TORSION, CHUTE DEFLECTOR	1
22	304424	ROD, PIVOT DECK .312 D X 7.25	1
23	3535	NUT, PUSH ON CAP .312 OD	1

www.emc.com

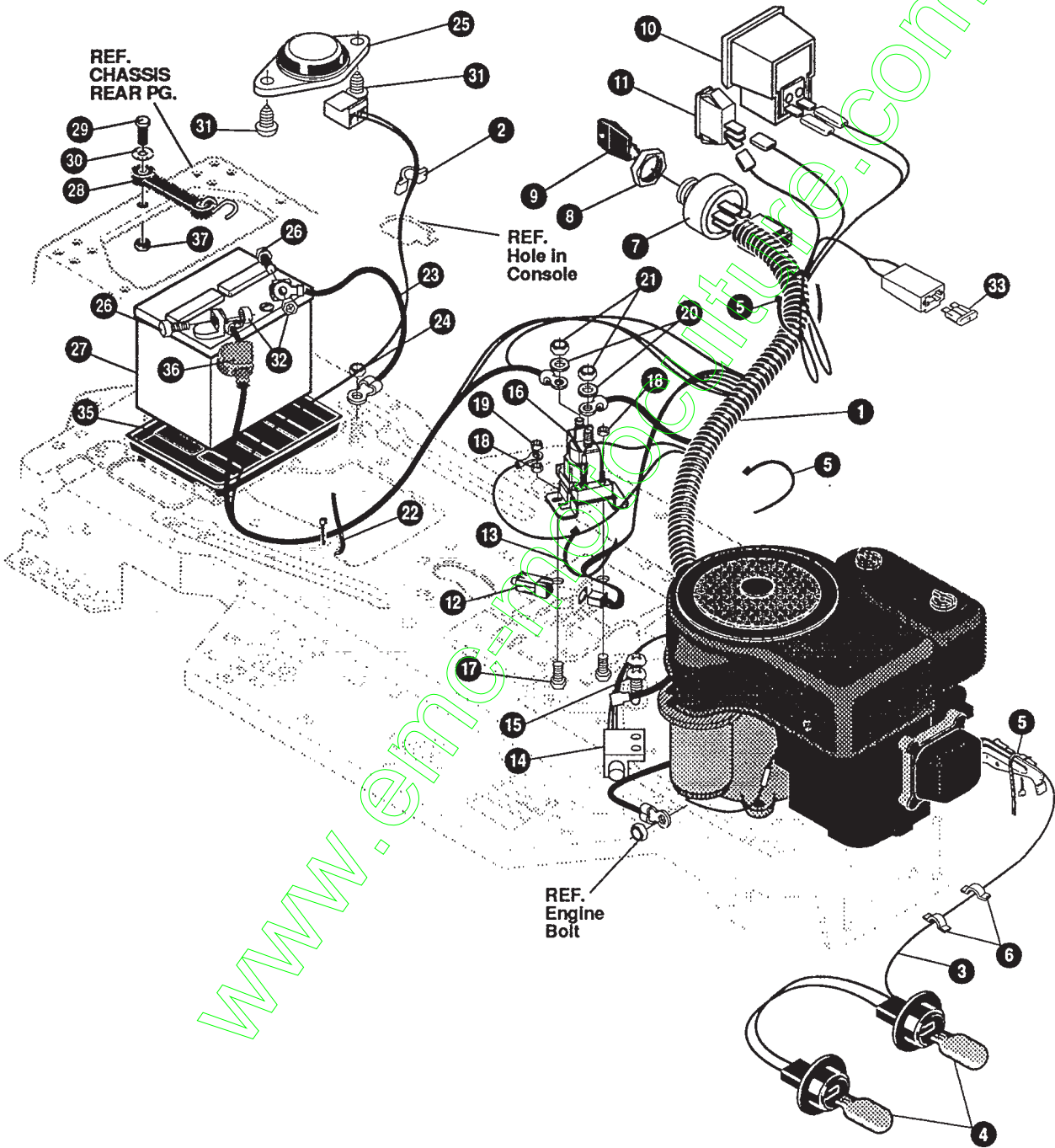

NOTE: ALWAYS USE ORIGINAL EQUIPMENT PARTS.
Use of service/replacement parts other than original equipment parts may void your warranty.

ALL UNNUMBERED ITEMS ARE INTERCHANGEABLE WITH OPPOSITE SIDE

336356 A

KEY#	PART#	DESCRIPTION	QTY
1	328253	HARNES,14HP, OHV, WRAPPED, DYN, LF	1
2	41482	PRESS CLIP, 1.380 LONG .255 ID	1
3	303064	ASSEMBLY, LIGHT WIRE-1/4 TURN	1
4	52572	BULB, HEADLAMP	2
5	57444	TIE, CABLE BLACK NYLON, 5.62 LONG	3
6	41482	PRESS CLIP, 1.380 LONG .255 ID	2
7	327355	SWITCH-IGNITION (AFTER FIRE) 3 POSITION	1
8	327352	NUT, 5/8-8 ACME DELTA FOR BOOT	1
9	327350	KEY, IGNITION	2
10	300133	AMMETER	1
11	300334	LIGHT SWITCH, ON/OFF, PANEL MOUNT	1
12	320082	SWITCH, DOUBLE POLE, NO/NC GRAY	1
13	57444	TIE, CABLE BLACK NYLON, 5.62 LONG	1
14	57476	SWITCH, SCREW MOUNT, DP, NC, NO BLACK	1
15	57220	SCREW, #12 X .50 PHPNHTAP, BLACK	2
16	53716	SOLENOID	1
17	187745	SCREW, 1/4-20 X .75 HXSEMMA	2
18	1502	NUT, 1/4-20 REGHEXCTRLK	2
19	271172	NUT, 1/4-20 REGHEXKEPS	1
20	138485	WASHER, EXLK .320 X .61 X .03	2
21	120368	NUT, 5/16-24 REGHEX	2
22	57444	TIE, CABLE BLACK NYLON, 5.62 LONG	1
23	55511	WIRE, GROUND, 12.5"	1
24	271184	NUT, 5/16-18 HEXKEPS	1
25	57547	SWITCH, SEAT	1
26	160505	SCREW, 1/4-20 X .38 PHPNHMA	2
27	92693	BATTERY,12V (MAINTENANCE FREE)	1
28	57505	RUBBER STRAP	1
29	180022	SCREW, 1/4-20 X 1.00 HHC	1
30	120392	WASHER, FLAT .281 X .63 X .065	1
31	180020	SCREW, 1/4-20 X .75 HHC	2
32	271172	NUT, 1/4-20 REGHEXKEPS	2
35	91895	TRAY - BATTERY	1
36	335417	BOOT, BATTERY MURRAY #54148	1
37	1502	NUT, 1/4-20 REGHEXCTRLK	1

SCHEMATIC DRAWING

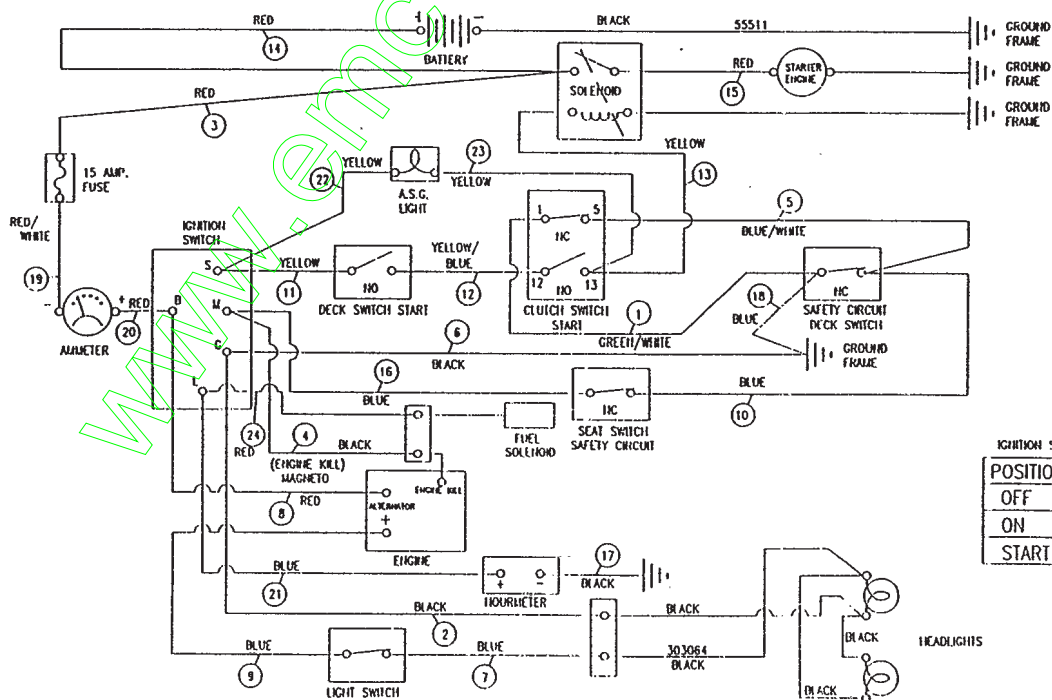

IGNITION SWITCH 305720

POSITION	G	M	L	B	S
OFF	•	•			
ON			•	•	
START					•

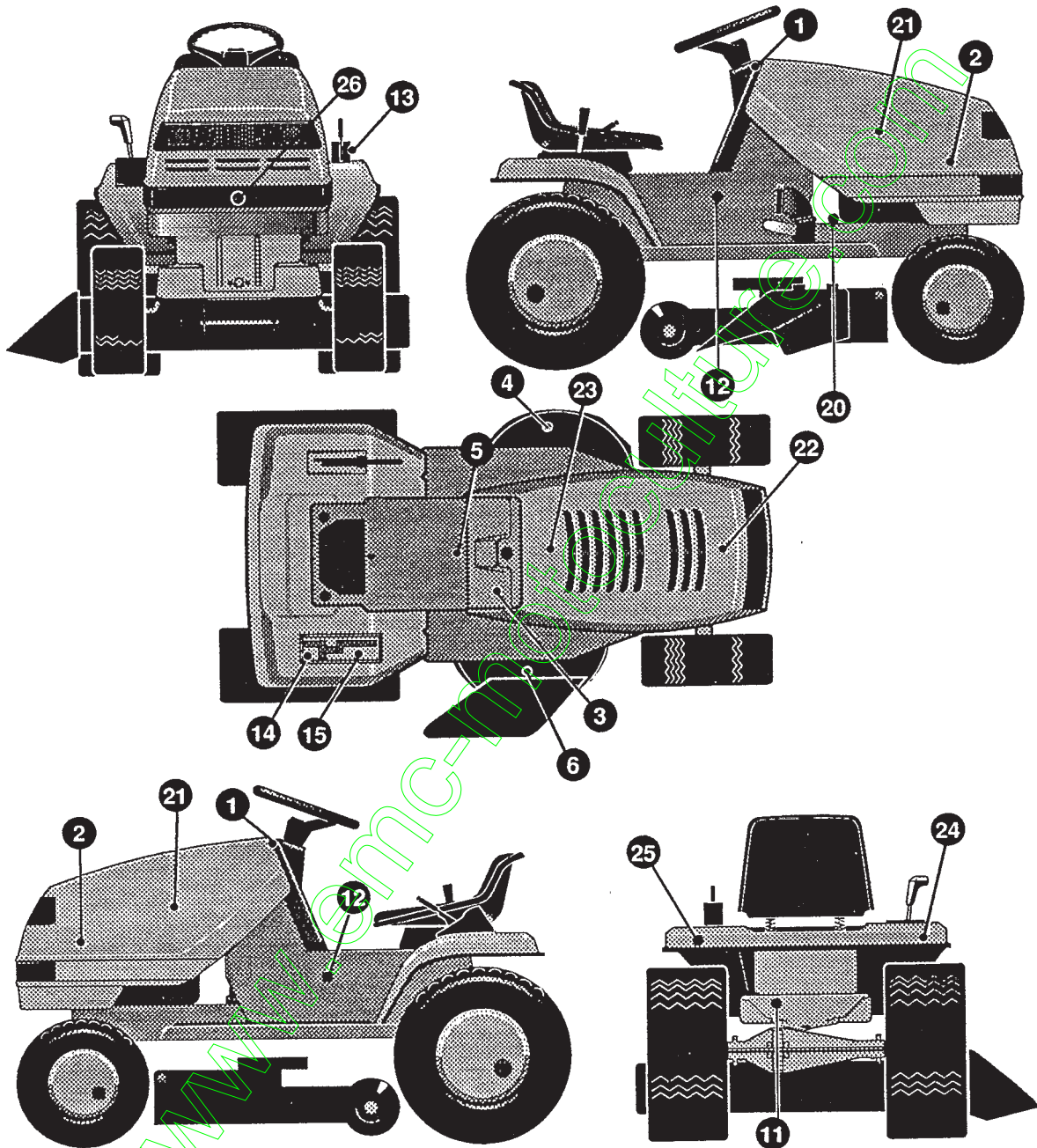

KEY#	PART#	DESCRIPTION	QTY
1	313208	DECAL, DASH WEAR STRIP, RED	2
2	301007	NAME PLATE, LG, DYNAMARK, WHITE	2
3	321765	DECAL, LF, DASH, PTO/LIGHT SWITCH, EXP	1
4	402700	DECAL, CAUTION DECK, LH	1
5	402689	DECAL, CONSOLE SYMBOLIC, CAUTION	1
6	402701	DECAL, CAUTION DECK, RH	1
11	335197	DECAL, AUTOMATIC DRIVE, DISCON	1
12	402661	NAMEPLATE, 14.5/40, WHITE	2
13	402214	DECAL, HEIGHT ADJUST	1
14	314925	DECAL, SHIFT, LF, HYDRO, REVERSE	1
15	314923	DECAL, SHIFTER, LF, HYDRO, FORWARD	1
20	402702	DECAL, BRAKE/CLUTCH	1
21	305603	PAD, 18 X 6 FOAM HOOD	2
22	307277	PAD, 12 X 4 FOAM HOOD	1
23	305602	FOAM, HOOD 4 X 15	1
24	320645	DECAL, AUTOMATIC TRANS (NP)	1
25	322313	DECAL, 4WS, M/F, BLACK ON SILVER	1
26	319986	DECAL, TAPE H15, 8MIL VINYL	1

www.emc-repair.com

Contact the dealer where your tractor was purchased for the available accessories. If you are unable to contact the dealer, write to the address on the warranty page of your Operator's manual.

LARGE LAWN TRACTOR

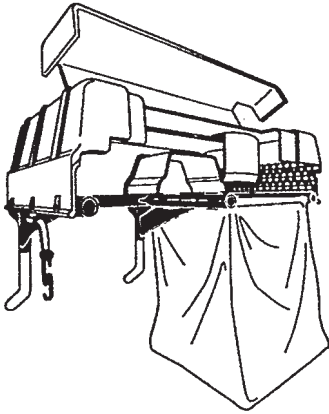

Model # 5708-34
Grass Collector for
40, 42, 43" decks

For heavy duty grass
collection order Model
#5709-10 Air Assist

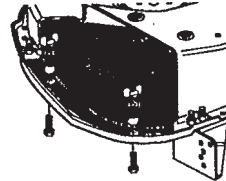

5717-00
Mulching Kit (42/43" Deck)
5716-00
Mulching Kit (40" Deck)

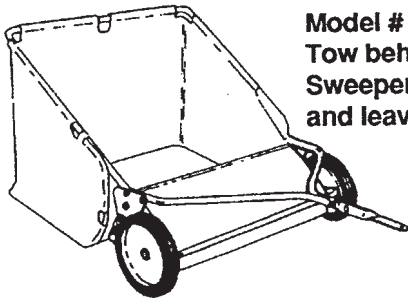
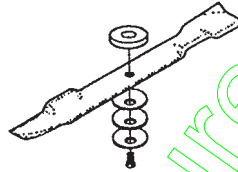

Model # 5648-16
Tow behind Lawn
Sweeper for grass
and leaves

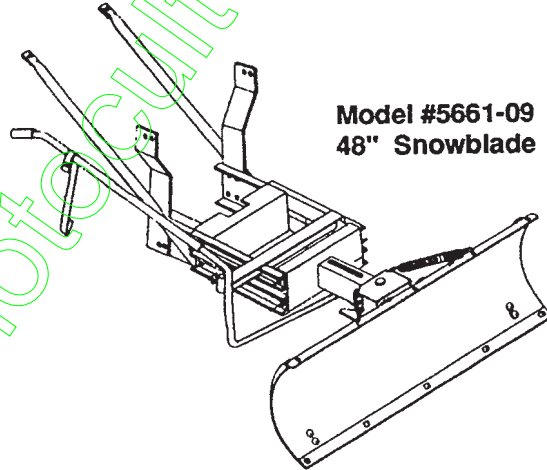

Model #5661-09
48" Snowblade

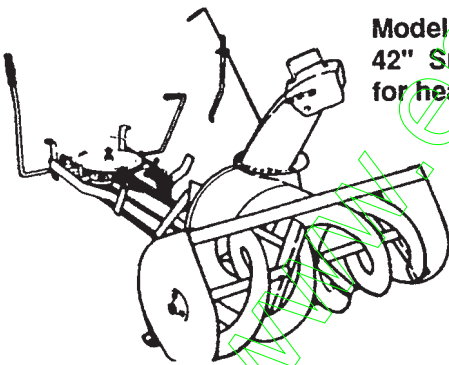

Model #5705-06
42" Snowthrower
for heavy snowfall

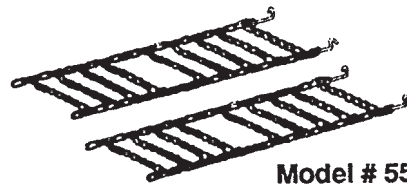

Model # 5585-00
Tire Chains - 20" x 8.0" tires
Model # 5706-00
Tire Chains - 20" x 10.0" tires

OTHER ACCESSORIES

Model	Description
5672-01	Wheel Weights - Front - 1 pr. w/mtg. hdw. - Fits 15" tires
5673-02	Wheel Weights - Rear - 1 pr. w/mtg. hdw. - Fits 18" & 20" tires
309070	40" High Lift Blade for Bagging or Side Discharge (Requires 2)
330277	40" Mulching Blade (Requires 2)
316608	43" High Lift Blade for Bagging or Side Discharge (Requires 2)
325762	43" Mulching Blade (Requires 2)