

# GTVH 200

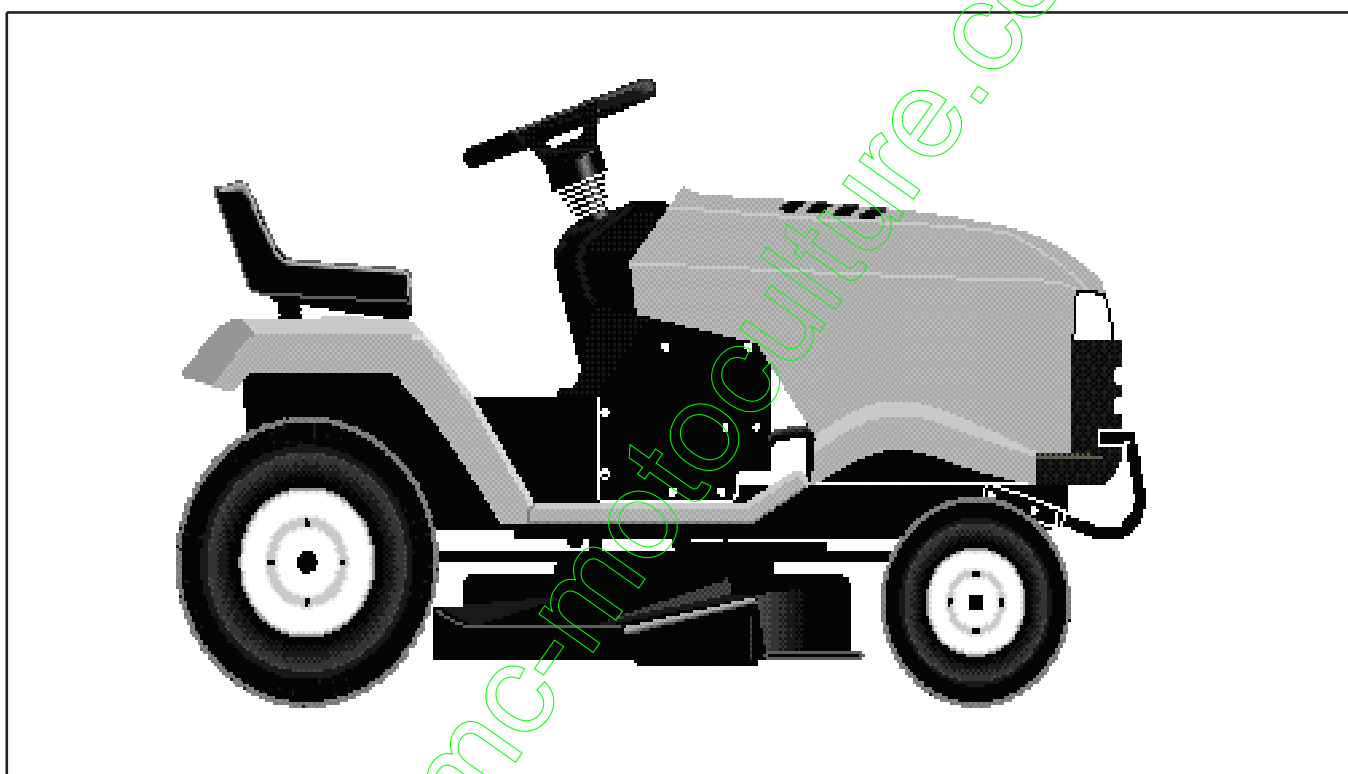

**10.1998**  
**PARTS LISTING**

**954140016A**

[www.emc-motoculture.com](http://www.emc-motoculture.com)

# REPAIR PARTS

TRACTOR - MODEL NO. GTVH200 (954140016A), PRODUCT NO. 954 14 00-16

## SCHEMATIC

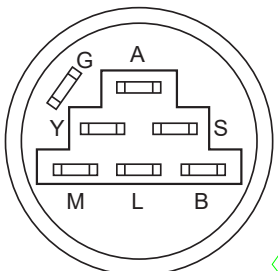
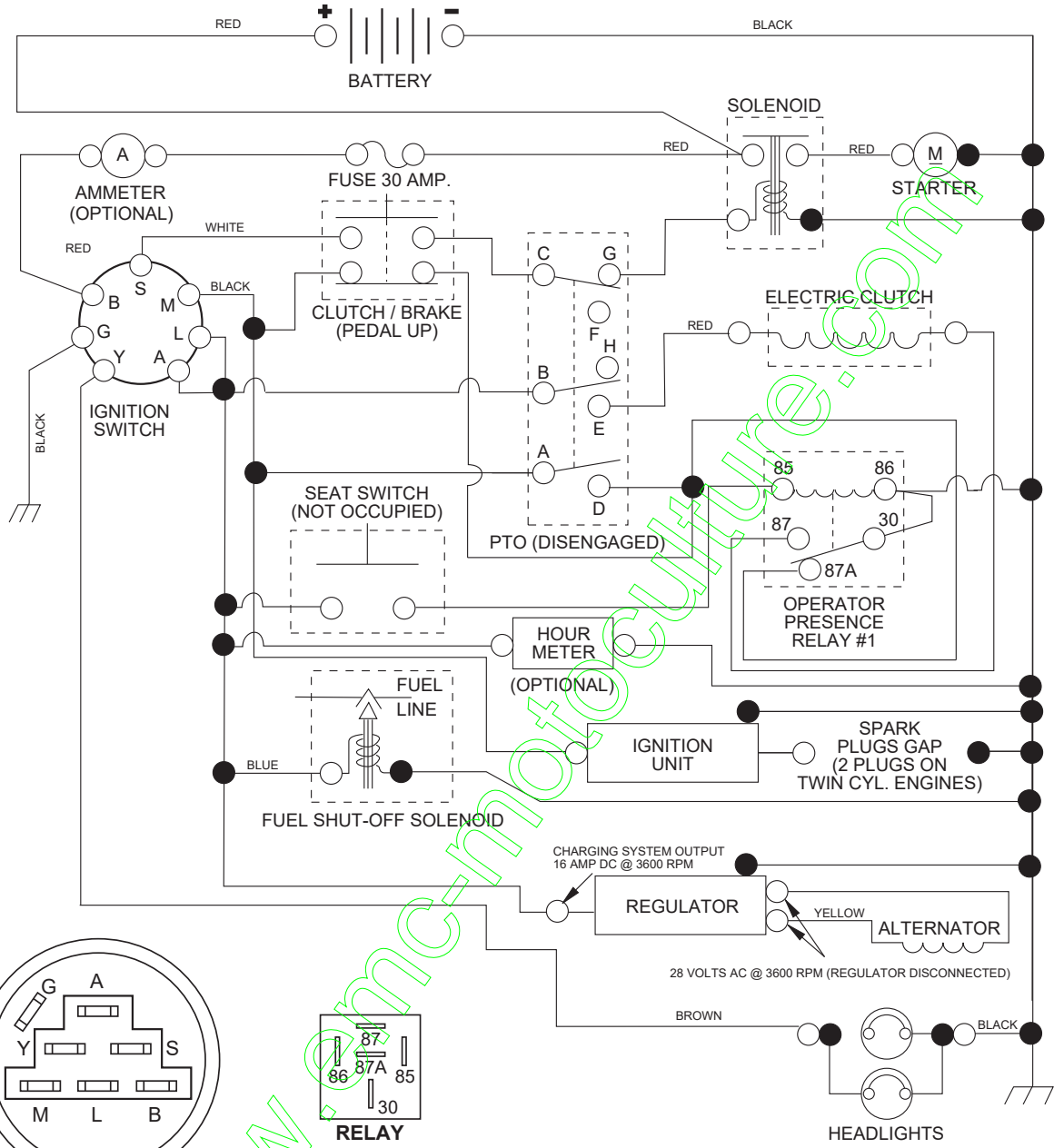

**IGNITION SWITCH**

POSITION	CIRCUIT	"MAKE"
OFF	G + M + L	NONE
RUN/LIGHT	B + L	A + Y
RUN	B + L	NONE
START	B + L + S	NONE

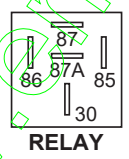

**RELAY**

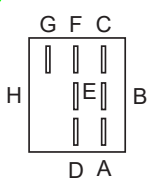

**PTO SWITCH**

POSITION	CIRCUIT
OFF	C + G, B + H
ON	C + F, B + E, A + D



**WIRING INSULATED CLIPS**  
**NOTE:** IF WIRING INSULATED CLIPS WERE REMOVED FOR SERVICING OF UNIT, THEY SHOULD BE REPLACED TO PROPERLY SECURE YOUR WIRING.

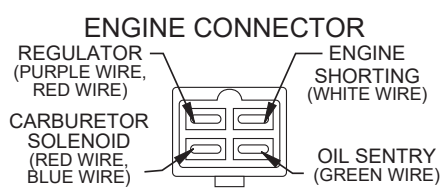

**ENGINE CONNECTOR**

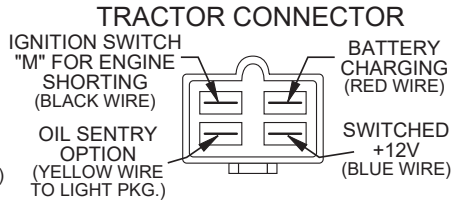

**TRACTOR CONNECTOR**

# REPAIR PARTS

TRACTOR - MODEL NO. GTVH200 (954140016A), PRODUCT NO. 954 14 00-16  
ELECTRICAL

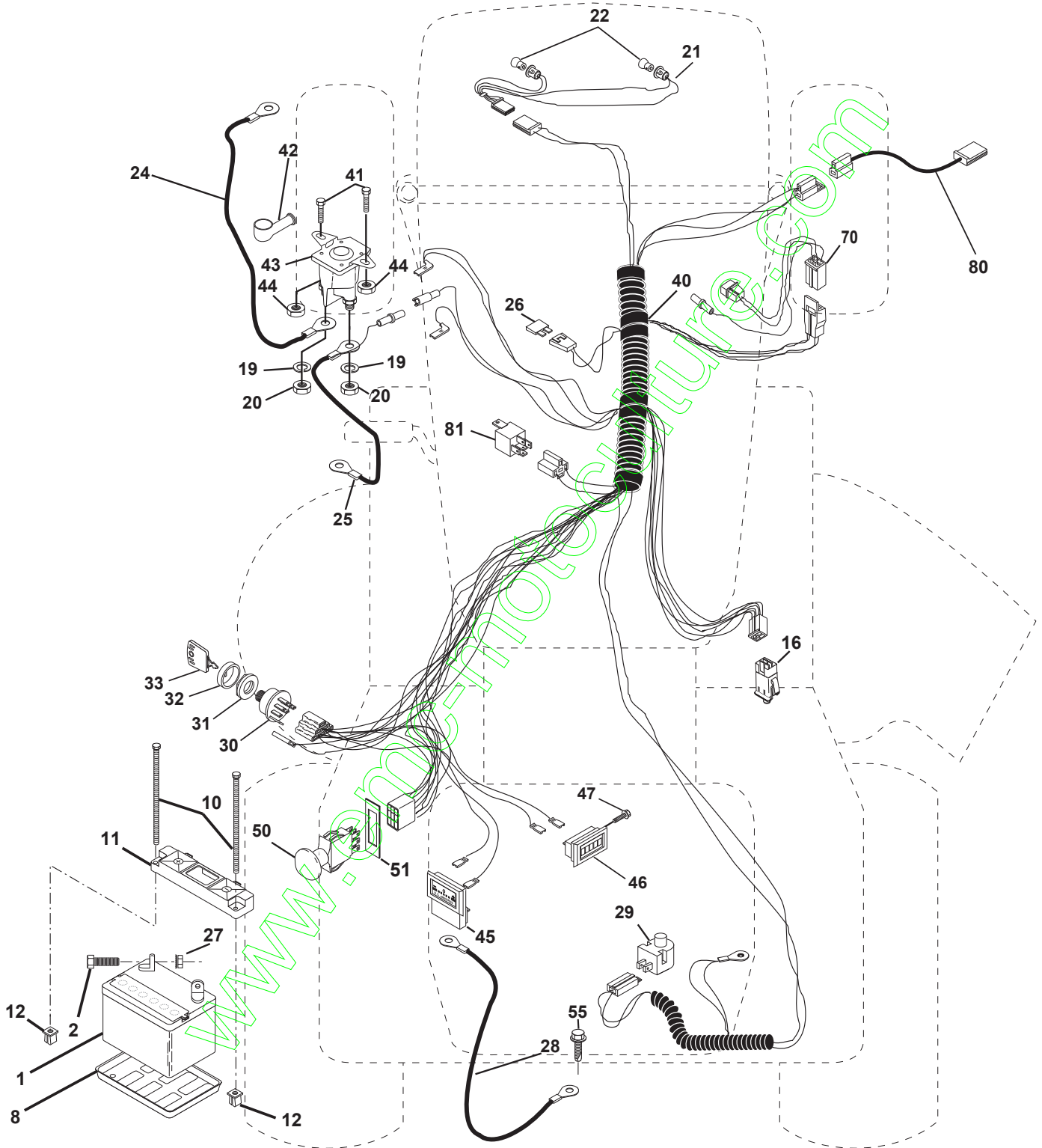

# REPAIR PARTS

TRACTOR - MODEL NO. GTVH200 (954140016A), PRODUCT NO. 954 14 00-16

## ELECTRICAL

KEY NO.	PART NO.	DESCRIPTION
1	532144927	Battery, 12 Volt, 35 Amp
2	874760412	Bolt, Hex Head 1/4-20 UNC x 3/4
8	532124886	Tray, Battery
10	532145211	Bolt, Battery Front 1/4-20 x 7.5 Zinc
11	532150109	Holddown Battery Dash Mount
12	532145769	Nut, Push Nylon 1/4" Battery Front
16	532153664	Switch Interlock Push-In
19	810090400	Washer, Lock 1/4
20	873350400	Nut, Jam, Hex Head 1/4-20 UNC
21	532136850	Harness, Light
22	532004152	Bulb, Light
24	532124780	Cable, Battery, 6 Gauge, 11", Red
25	532146148	Cable, Battery
26	532108824	Fuse, 30 Amp
27	873510400	Nut, Hex, Keps 1/4-20 UNC
28	532145491	Cable, Ground, 6 Gauge, 12", Black
29	532160784	Switch, Plunger, Normal Op Olive
30	532140301	Switch, Ignition, 4 Position
31	532124211	Nut, Ignition
32	532141226	Cover, Ignition Switch
33	532122147	Key, Ignition
40	532160719	Harness, Ignition
41	871110408	Bolt, Hex, Fin. 1/4-20 x 1/2
42	532131563	Cover, Terminal, Red
43	532145673	Solenoid
44	873640400	Nut, Hex, Keps 1/4-20 UNC
45	532122822	Ammeter, Rectangular, 15 AMP
46	532110940	Meter, Hour
47	817011008	Screw 10-24 x 1/2 Black
50	532154959	Switch, PTO
51	532140405	Ring, Retainer, PTO
55	817490508	Screw, Thdrol 5/16-18 x 1/2 TYT
70	532143346	Harness, Engine
80	532146685	Harness Clutch EVX
81	532109748	Relay Assembly

**NOTE:** All component dimensions given in U.S. inches  
1 inch = 25.4 mm

# REPAIR PARTS

TRACTOR - MODEL NO. GTVH200 (954140016A), PRODUCT NO. 954 14 00-16  
CHASSIS AND ENCLOSURES

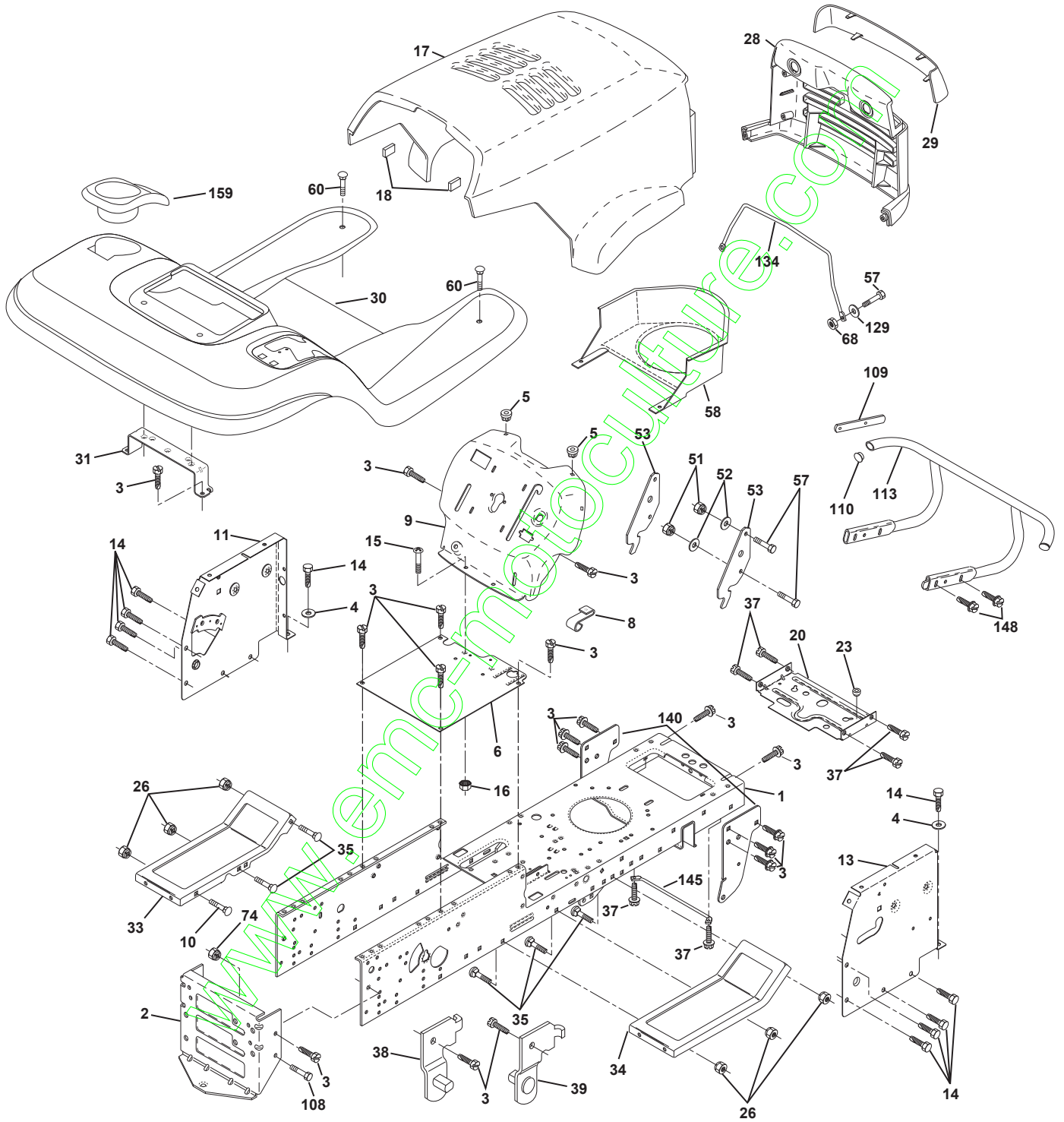

# REPAIR PARTS

TRACTOR - MODEL NO. GTVH200 (954140016A), PRODUCT NO. 954 14 00-16

## CHASSIS AND ENCLOSURES

KEY NO.	PART NO.	DESCRIPTION
1	532160393	Chassis Weldment
2	532140356	Drawbar
3	817490612	Screw Thdrol 3/8-16x3/4 Ty-tt
4	819131216	Washer 13/32 x 3/4 x 16 Ja.
5	532155272	Bumper
6	532155923	Saddle
8	532126471	Clip Insulator
9	532166689	Dashboard
10	872140608	Bolt
11	532156682	Panel Asm.
13	532164335	Panel Asm.
14	817490608	Screw 3/8-16 x 1/2 Ty-Tt
15	874180512	Screw 5/16-18 Unc x 3/4
16	873510500	Nut Keps 5/16-18 Unc
17	532165378	Hood
18	532126938	Bumper
20	532156437	Plate Mtg Battery/Fuel Tank
23	532124028	Bushing
24	874780616	Bolt 3/8-16 Unc x 1 Gr. 5
25	819131312	Washer 13/32 x 13/16 x 12 Ga.
26	873800600	Nut Lock w/Insert 3/8-16 UNC
28	532165379	Grille
29	532165380	Grille Lens
30	532166623	Fender
31	532137113	Bracket
33	532147203	Foot Rest, L.H.
34	532147202	Foot Rest, R.H.
35	872110606	Bolt 3/8-16 x 3/4
37	817490508	Screw 5/16-18 x 1/2 Tyt
38	532139886	Bracket Asm Pivot LH
39	532139887	Bracket Asm Pivot RH
44	532140675	Strap Asm. Fender
47	532105531	Nylon Washer
51	873800400	Lock Nut 1/4-20
52	819091416	Washer 9/32 x 7/8 x 16 Ga.
53	532150067	Bracket LT/PL Husq.
57	874780412	Hex Bolt 1/4-20 x .75
58	532162266	Duct Intake Air
68	873510400	Nut Keps 1/4-20 UNC
74	873680600	Nut, Crownlockt 3/8-16 UNC
108	874760612	Hex Bolt 3/8-16 UNC x 3.4
109	532141461	Bracket Extension Bumper
110	532143679	Plug Plastic
113	532150300	Bumper Asm.
129	819091016	Washer 9/32 x 5/8 x 16 Ga.
134	532160219	Rod Support Hood
140	532158418	Bracket Suspension Front
145	532156524	Rod Pivot Chassis Hood
148	817490620	Screw Throl 3/8-16 x 1-1/4
159	532166625	Cupholder YTGT Grey

**NOTE:** All component dimensions given in U. S. inches.  
1 inch = 25.4 mm

# REPAIR PARTS

TRACTOR - MODEL NO. GTVH200 (954140016A), PRODUCT NO. 954 14 00-16

## DRIVE

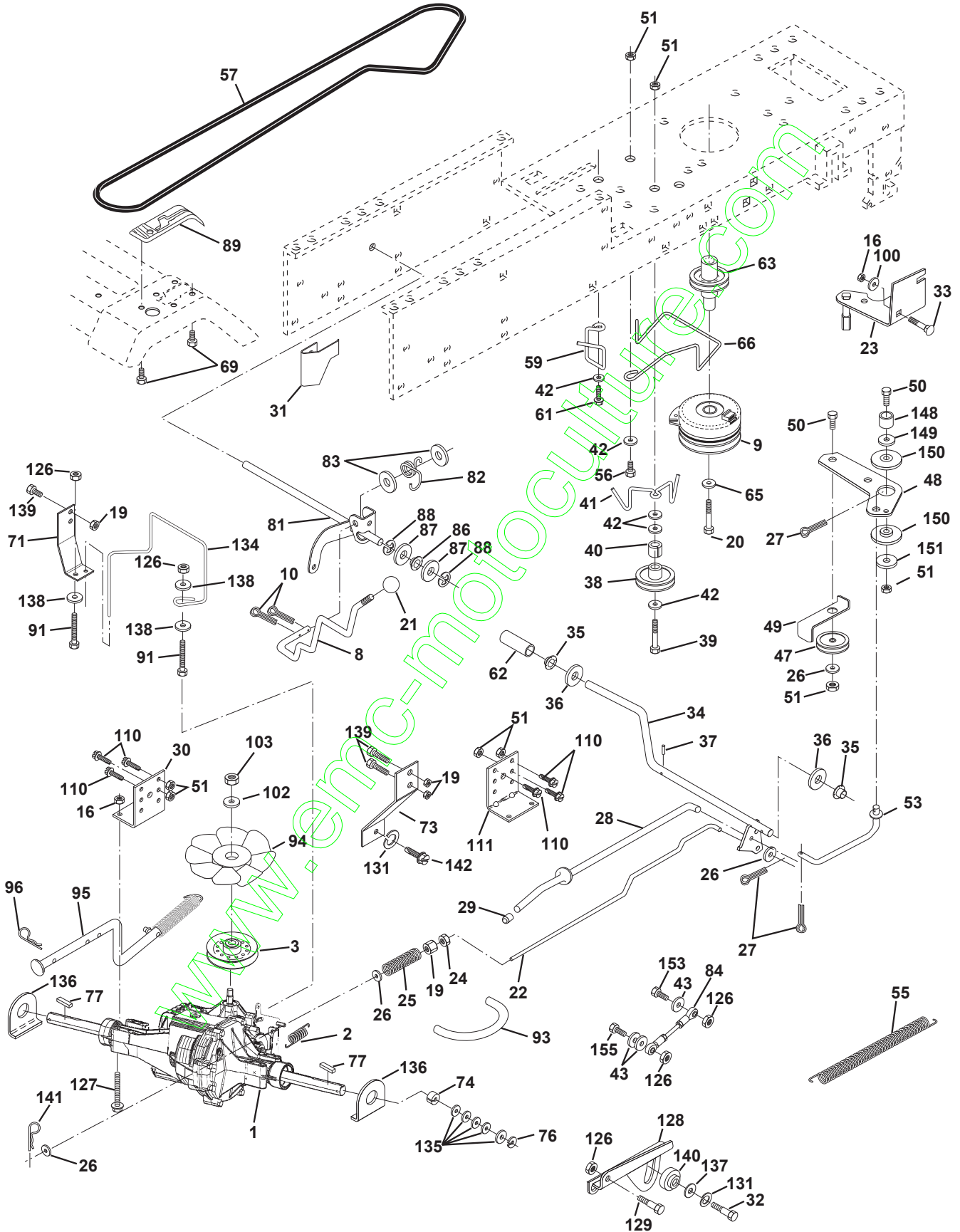

# REPAIR PARTS

TRACTOR - MODEL NO. GTVH200 (954140016A), PRODUCT NO. 954 14 00-16

## DRIVE

KEY NO.	PART NO.	DESCRIPTION	KEY NO.	PART NO.	DESCRIPTION
1	532157981	Transaxle, (See Breakdown)	69	532142432	Screw
		Hydro Gear Model No. 314-3000	71	532158283	Torque Fastener L.H.
2	532142431	Spring, Brake Return	73	532158282	Torque Fastener R.H.
3	532143995	Pulley, Transaxle	74	532160849	Spacer, Split
8	532141002	Rod, Shifter	76	812000053	E-Ring
9	532160889	Clutch Elect EVX 80 lb.	77	532124762	Key, Square
10	876020416	Pin, Cotter 1/8 x 1	81	532161271	Shaft Asm.
16	873800500	Nut, Lock Hex w/Ins. 5/16-18 UNC	82	532123782	Spring, Torsion
19	873800600	Nut, Lock Hex w/Washer 3/8-16 UNC	83	819171216	Washer 17/32 x 3/4 x 16 Ja.
20	532150280	Bolt Hex 7/16-20 x 4-1/4 5 Ga.	84	532163470	Tie Rod
21	532140845	Knob Delux 1/2-13 Unc	86	532157480	Bushing
22	532158274	Rod, Brake	87	819212016	Washer 21/32 x 1-1/4 x 16 Ja.
23	532154978	Bracket Asm Clutch Mtg. Evx	88	812000008	Clip, Ring
24	873350600	Nut, Hex Jam 3/8-16	89	532166624	Console, Speed
25	532106888	Spring, Rod, Brake	91	874780536	Bolt, Hex 5/16-18 x 2-1/4
26	819131316	Washer 13/32 x 13/16 x 16 Ja.	93	532142564	Fuel Line
27	876020412	Pin, Cotter 1/8 x 3/4	94	532140462	Fan 7"
28	532145204	Rod, Brake, Park	95	532158508	Control Assembly Bypass Hydro
29	532071673	Cap, Brake Parking Black	96	532124788	Retainer, Spring 1"
30	532123780	Bracket, Transaxle	100	819111216	Washer 11/32 x 3/4 x 16 Ja.
31	532123791	Keeper, Belt, Transaxle,	102	532141322	Washer .501 x 1.50D
32	874760512	Hex Bolt 5/16-18 UNC x 3/4	103	873940800	Nut Hex Jam Toplock 1/2-20 UNF
33	872140506	Bolt Rdhd Sqnk 5/16-18 Unc x 3/4	110	874760612	Bolt, Hex 3/8-16 UNC x 3/4
34	532155071	Shaft, Foot Pedal	111	532123776	Bracket
35	532120183	Bearing Nylon	126	532124949	Locknut
36	819211616	Washer	127	874490548	Bolt, Hex 5/16-18 UNC x 3
37	532124963	Pin, Roll	128	532158284	Bracket
38	532131494	Idler, Flat	129	532105529	Bolt 5/16-18 UNC
39	874760644	Bolt	131	810140500	Push Nut 5/16
40	532124965	Spacer, Split	134	532158278	Belt, Guide
41	532165838	Keeper, Idler	135	532123800	Washer 1-1/32 x 1-5/8 x 16 Ja.
42	819131312	Washer 13/32 x 13/16 x 12 Ja.	136	532163168	Washer
43	819111012	Washer 11/32 x 5/8 x 12 Ga.	137	819111212	Washer 11/32 x 3/4 x 12 Ja.
47	532127783	Pulley, Idler	138	819112016	Washer 11/32 x 1.25 x 16 Ja.
48	532154407	Bellcrank Clutch Grnd Drv Stl	139	874780612	Bolt, Hex 3/8-16 UNC x 3/4
49	532123205	Retainer, Belt	140	532004475	Bushing
50	874760624	Bolt, Hex 3/8-16 x 1-1/2	141	532159197	Pin
51	873680600	Nut, Crownlock 3/8-16	142	874330516	Bolt 5/16 x 24 x 1
53	532105710	Link, Clutch	148	532159103	Spacer
55	532105709	Spring, Return, Clutch	149	532122052	Retainer Spring
56	874760620	Bolt, Hex 3/8-16 UNC x 1-1/4	150	532150935	Nylon, Bushing
57	532161741	V-Belt Drive	151	819133210	Washer 13/32 x 2 x 10 Ja.
59	532140312	Keeper Belt Centerspan	153	874760516	Bolt, Hex 5/16-18
62	532123533	Cover, Foot Pedal	155	874760520	Bolt Fin Hex 5/16-18 Unc x 1.25
63	532161400	Engine Pulley			
65	810040700	Washer			
66	532161488	Keeper, Belt Engine			

**NOTE:** All component dimensions given in U.S. inches  
1 inch = 25.4 mm



# REPAIR PARTS

TRACTOR - MODEL NO. GTVH200 (954140016A), PRODUCT NO. 954 14 00-16

## STEERING ASSEMBLY

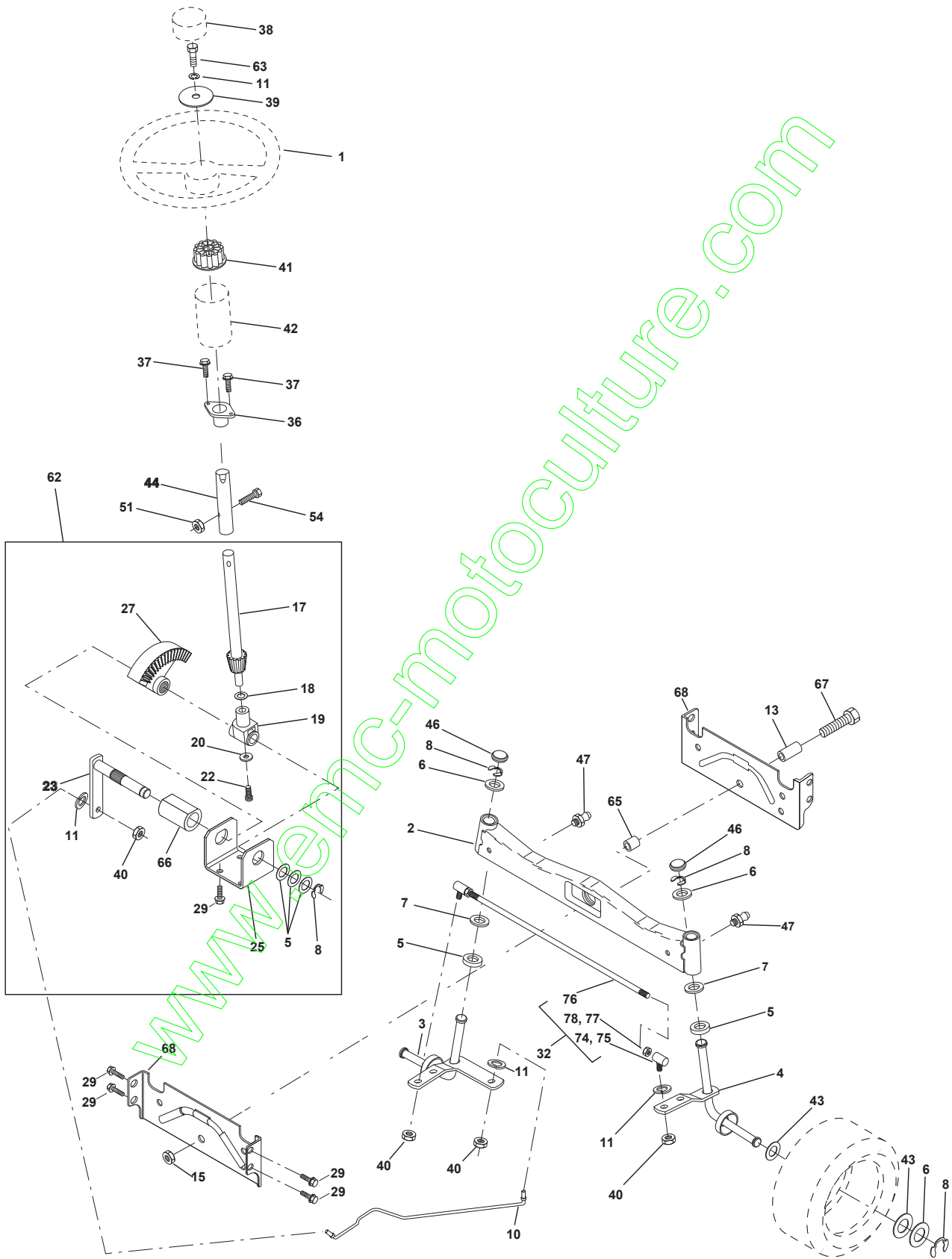

# REPAIR PARTS

TRACTOR - MODEL NO. GTVH200 (954140016A), PRODUCT NO. 954 14 00-16

## STEERING ASSEMBLY

KEY NO.	PART NO.	DESCRIPTION
1	532124415	Steering Wheel
2	532137094	Axle, Front
3	532157479	Spindle, L.H.
4	532157478	Spindle, R.H.
5	532124931	Bearing, Thrust
6	532121748	Washer 25/32 x 1-5/8 x 16 Gauge
7	819272016	Washer 27/32 x 1-1/4 x 16 Ga.
8	812000029	Klip Ring
10	532154432	Link, Drag
11	810040600	Washer, Lock 3/8
12	873940800	Nut, Hex, Jam, Top Lock 1/2-20 UNF
13	532154779	Spacer, Bearing, Front Axle
15	873901000	Locknut, Hex with Washer Insert 5/8-11 UNC
17	532156546	Shaft, Steering
18	532057079	Washer
19	532124035	Shaft, Support
20	532126684	Washer 5/8 x 1/4 x 16 Gauge
22	871200410	Screw Hex Socket 1/4-20 x 5/8
23	532127501	Shaft, Pitman
25	532154406	Bracket, Steering
27	532136874	Gear, Sector
29	817490612	Screw, Hex Washer Head, Thdrol. 3/8-16 x 3/4
32	532137347	Rod, Tie
36	532155099	Bushing Steering
37	532152927	Screw TT #10-32 X 5 x 3/8 Flange
38	532124416	Insert, Steering Wheel
39	819133808	Washer
40	532124701	Nut, Lock Center 3/8-24 UNF
41	532100711	Adapter, Steering Wheel
43	532121749	Washer, 25/32 x 1-1/4 x 16 Gauge
44	532153720	Extension Steering Non-Adjust
46	532121232	Spindle, Cap
47	532124836	Grease Zerk
51	873800500	Nut Lock Hx w/Ins. 5/16-18 Unc
54	874780520	Bolt Fin Hex 5/16-18 Unc x 1-1/4
62	532156594	Kit Steering Asm Service
63	874780616	Bolt Fin Hex 3/8-16 Unc x 1 Gr. 5
65	532154780	Spacer Axle
66	532154404	Bearing Arm Pittman
67	874781044	Bolt Fin Hex 5/8-11 UNC x 2-3/4
68	532154429	Brace Axle
74	532109850	Joint Asm Ball Rh
75	532109851	Joint Asm Ball Lh
76	532137156	Rod Tie Ball J Adj
77	873700600	Nut Hex Jam 3/8-24 Unf Lh
78	873360600	Nut Hex Jam 3/8-24 Unf

**NOTE:** All component dimensions given in U.S. inches.  
1 inch = 25.4 mm

# REPAIR PARTS

TRACTOR - MODEL NO. GTVH200 (954140016A), PRODUCT NO. 954 14 00-16  
ENGINE

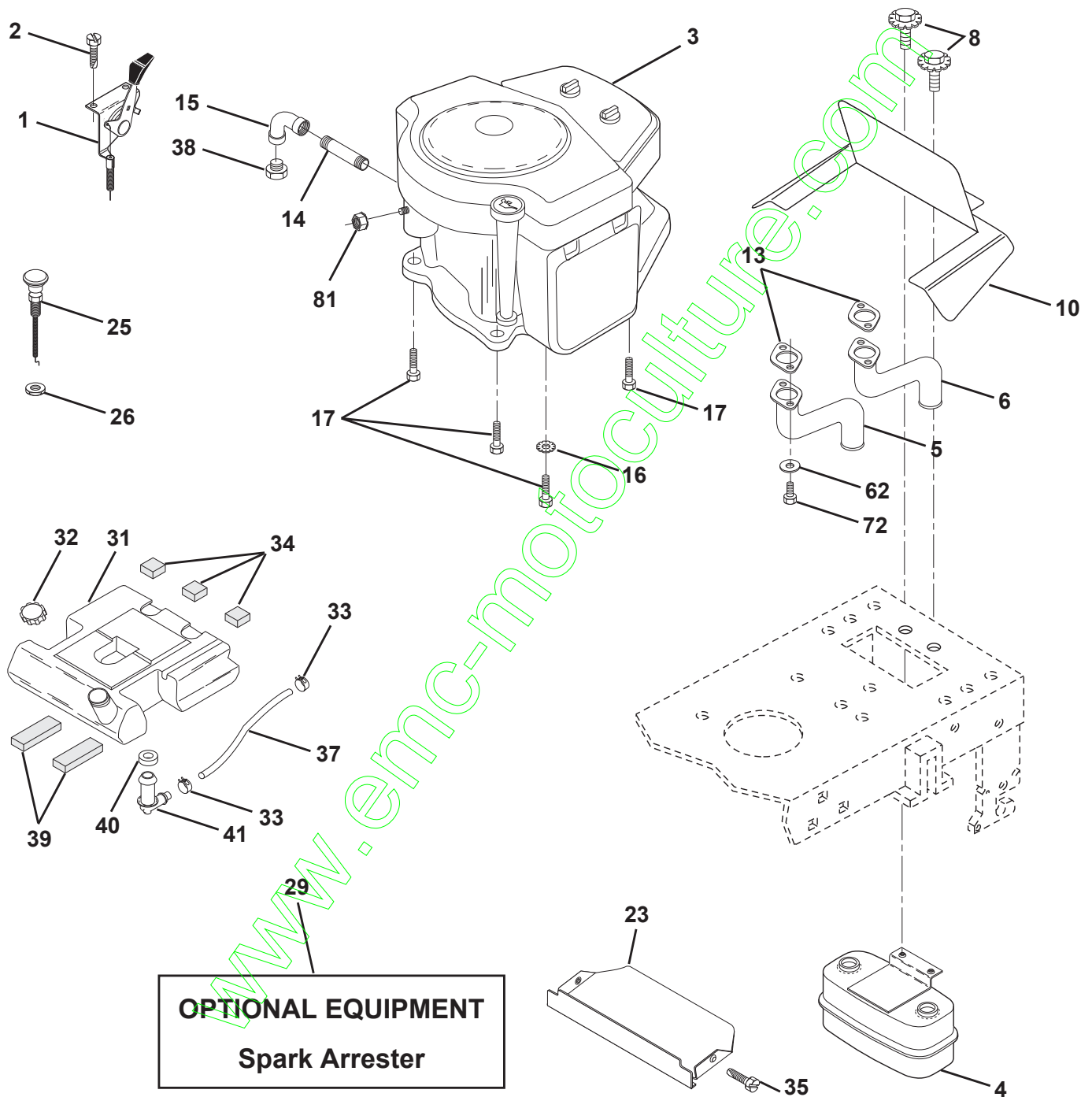

# REPAIR PARTS

TRACTOR - MODEL NO. GTVH200 (954140016A), PRODUCT NO. 954 14 00-16

## ENGINE

KEY NO.	PART NO.	DESCRIPTION
1	532148875	Control, Throttle
2	817720410	Screw, Hex Head, Thread Cutting 1/4-20 x 5/8
3	-----	Engine, B&S Model Number 407777
4	532149723	Muffler
5	532159955	Tube, Manifold, LH
6	532160589	Tube, Manifold, RH
8	532150176	Bolt 5/16-18 UNC x 3/4 w/Sems
10	532162797	Shield, Browning
12	871070512	Screw, Hex Socket Head 5/16-18 x (Order from engine mfg.)
13	532165391	Muffler Gasket (Order from Engine Manufacturer)
15	813200300	Elbow, Standard 90° 3/8-18 NPT
16	811050600	Washer, Lock, External Tooth 3/8
17	817490624	Screw Thdrol 3/8-16 x 1-1/2
23	532159880	Shield, Browning / Debris Guard
25	532145996	Choke Control
26	873920600	Nut, Keps 3/8-24 UNF
29	532137180	Kit, Spark Arrestor
31	532151346	Tank Fuel 3 50 Rear
32	532140527	Cap Asm Fuel W/sym Vented
33	532123487	Clamp, Hose
34	532106082	Pad, Spacer
35	817490512	Screw, Thd. Roll. 5/16-18 x 3/4
37	532007833	Line, Fuel
38	-----	Plug, Oil Drain (Order From Engine Manufacturer)
39	532109227	Pad, Idler
40	532003645	Bushing
41	532139277	Stem, Fuel Tank
62	810040500	Washer, Lock 5/16 (Order from engine mfg.)
72	813280336	Nipple, Pipe 3/8 NPT x 4-1/2
81	532128861	Nut, Flange 1/4-20 Starter Nut

**NOTE:** All component dimensions given in U.S. inches.  
1 inch = 25.4 mm

# REPAIR PARTS

TRACTOR - MODEL NO. GTVH200 (954140016A), PRODUCT NO. 954 14 00-16  
MOWER DECK

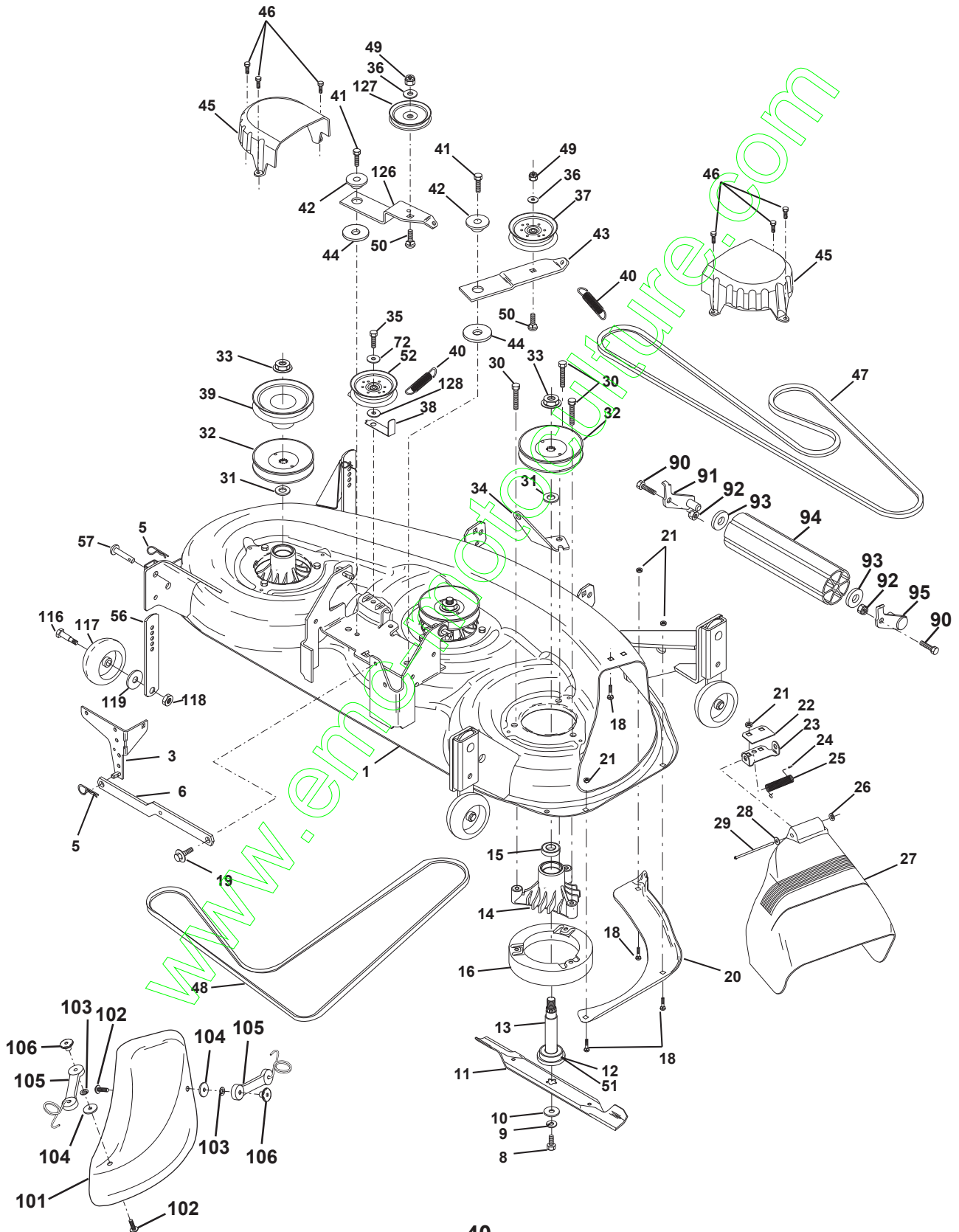

# REPAIR PARTS

TRACTOR - MODEL NO. GTVH200 (954140016A), PRODUCT NO. 954 14 00-16

## MOWER DECK

KEY NO.	PART NO.	DESCRIPTION	KEY NO.	PART NO.	DESCRIPTION
1	532164212	Deck Asm., Mower 46"	43	532144949	Arm, Idler Secondary
3	532138457	Bracket Asm., Sway Bar	44	532133943	Washer, Hardened
5	532124670	Retainer Spring	45	532145059	Cover, Mandrel Deck
6	532130832	Arm, Suspension, Rear (Sway Bar)	46	532137729	Screw, Thdroll. 1/4-20 x 5/8
8	532850857	Bolt, Patched 3/8-24 x 1-1/4 Gr. 8	47	532144959	V-Belt, Mower, Secondary
9	810030600	Washer, Lock Hvy., Unplated 3/8	48	532148763	V-Belt, Mower, Primary
10	532140296	Washer, Hard Blade, Mower Vented	49	873680600	Nut, Crownlock 3/8-16 UNC
11	532163819	Blade, 46" Mower Deck	50	872110612	Bolt, Carriage 3/8-16 x 1-1/2 Gr. 5
12	532129895	Bearing, Ball, Mandrel #6204	51	532153390	Washer Felt
13	532137553	Shaft Asm. w/Lower Bearing (Includes Key No. 12)	52	532156493	Pulley Idler 46 Pri Drive 97
14	532137152	Housing, Mandrel	56	532155986	Bar Adjusting Gauge Wheel
15	532110485	Bearing, Ball, Mandrel	57	532156941	Pin Head Rivet
16	532140329	Stripper, Mower Round	72	819131616	Washer 13/32 x 1 x 16 Ga.
18	872140505	Bolt, Carriage 5/16-18 x 5/8	90	874760616	Bolt, Fin Hex 3/8-16 UNC x 1
19	532132827	Bolt, Hex Head, Shoulder 5/16-18	91	532132274	Bracket Asm. Noseroller, Lh
20	532145055	Baffle, Vortex Mower 46"	92	873800600	Nut Lock Hex w/Ins 3/8-16 UNC
21	873680500	Nut, Crownlock 5/16-18 UNC	93	819171416	Washer 17/32 x 7/8 x 16 Ga.
22	532134753	Stiffener, Bracket	94	532132264	Roller Nose 38 & 42
23	532131267	Bracket, Deflector	95	532132273	Bracket Asm. Noseroller, Rh
24	532105304	Cap, Sleeve	101	532145579	Cover Mulcher
25	532149287	Spring, Torsion, Deflector	102	871161010	Screw Truss Hd Phil 10-24 x 5/8
26	532110452	Nut, Push	103	810071000	Washer Lock #10
27	532157788	Shield, Deflector Mower	104	532125004	Nut Weld
28	819111016	Washer 11/32 x 5/8 x 16 Ga.	105	819061216	Washer #10
29	532131491	Rod, Hinge	106	532160793	Latch Asm Mulch/Bagger
30	532157722	Screw, Thdroll Washer Head	116	532137644	Bolt, Shoulder
31	532129963	Washer, Spacer Mower Vented	117	532133957	Gauge Wheel
32	532153531	Pulley, Mandrel	118	873930600	Nut, Centerlock 3/8-16 UNC
33	532137266	Nut, Flg. Top Lock Cntr. 9/16	119	819121414	Washer 3/8 x 7/8 x 14 Ga.
34	532144945	Anchor, Spring Deck 46"	126	532144948	Arm, Idler, Primary Deck 46"
35	817490628	Screw, Thdroll 3/8-16 x 1-3/4 Tytt	127	532146763	Pulley, Idler, V-Groove Dim. 4.25
36	819131316	Washer 13/32 x 13/16 x 16 Ga.	128	819132203	Washer 13/32 x 1-3/8 x 3 Ga.
37	532131494	Pulley, Idler, Flat	--	532143651	Mandrel Asm 44"/46"/50" Service
38	532156086	Keeper, Belt, Idler	--	532166208	Deck Complete (Std. Deck-Order separately nose roller and gauge wheel components Key Nos. 90-95 and 116-118)
39	532144917	Pulley, Idler, Driven			
40	532137273	Spring, Secondary 44/46/50 Vent			
41	817490620	Screw, Thdroll 3/8-16 x 1-1/4 Tytt			
42	532122052	Spacer, Retainer			

**NOTE:** All component dimensions given in U.S. inches  
1 inch = 25.4 mm

# REPAIR PARTS

TRACTOR - MODEL NO. GTVH200 (954140016A), PRODUCT NO. 954 14 00-16  
MOWER LIFT

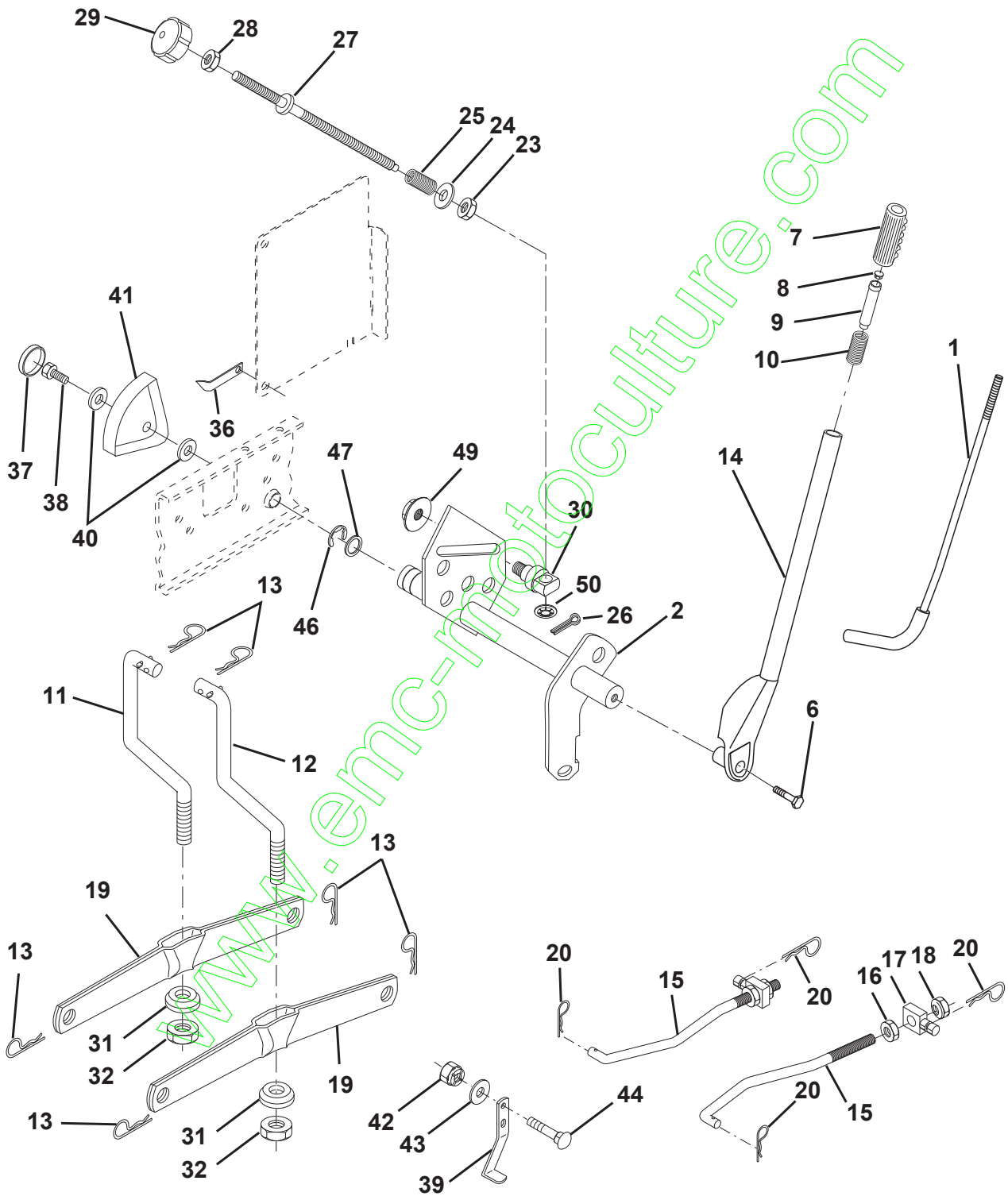

# REPAIR PARTS

TRACTOR - MODEL NO. GTVH200 (954140016A), PRODUCT NO. 954 14 00-16

## MOWER LIFT

KEY NO.	PART NO.	DESCRIPTION
1	532121006	Rod Assembly, Lever
2	532159188	Shaft Assembly, Lift
6	874780624	Bolt, Hex Head, Fin. 3/8-16 x 1-1/2
7	532125631	Grip Handle
8	532124526	Button Plunger Black
9	532122364	Plunger Lever Lift
10	532124874	Spring
11	532145537	Link, Lift, LH
12	532145536	Link, Lift, RH
13	532124670	Retainer Spring
14	532159189	Lever Assembly, Lift, RH
15	532127218	Link, Front
16	873350800	Nut, Hex, Jam 1/2-13 UNC
17	532130171	Trunnion
18	873680800	Nut Crownlock 1/2-13 Unc
19	532139868	Arm, Suspension, Rear
20	532163552	Retainer Spring
23	532110807	Nut, Special
24	819131016	Washer 13/32 x 5/8 x 16 Gauge
25	532124874	Spring
26	876020308	Pin, Cotter 3/32 x 1/2
27	532126971	Adjustment Rod, Lift
28	873350600	Nut, Hex, Jam 3/8-16 UNC
29	532138057	Knob, Infinite Height Adjustment
30	532150233	Trunnion, Inf. Height
31	532140302	Bearing
32	873540600	Nut, Crownlock 3/8-24
36	532155097	Pointer Height Indicator
37	532123935	Plug Hole Blk 1.485/1.515 Dia.
38	817490512	Screw Thdrol 5/16-18 x 3/4
39	532142992	Stop Over Center
40	819112410	Washer 11/32 x 1-1/2 10 Ga.
41	532123934	Scale Ind. Height Blk.
42	873680600	Nut, Crownlock 3/8-16 UNC
43	819131612	Washer 13/32 x 1 x 12 Ga.
44	872240608	Bolt, Carriage 3/8-16 x 1.00
46	812000022	E-Ring
47	819292016	Washer
49	532145212	Nut Hex Flange Lock
50	532110452	Nut Push Phos & Oil

**NOTE:** All component dimensions given in U.S. inches  
1 inch = 25.4 mm



# REPAIR PARTS

TRACTOR - MODEL NO. GTVH200 (954140016A), PRODUCT NO. 954 14 00-16

## SEAT ASSEMBLY

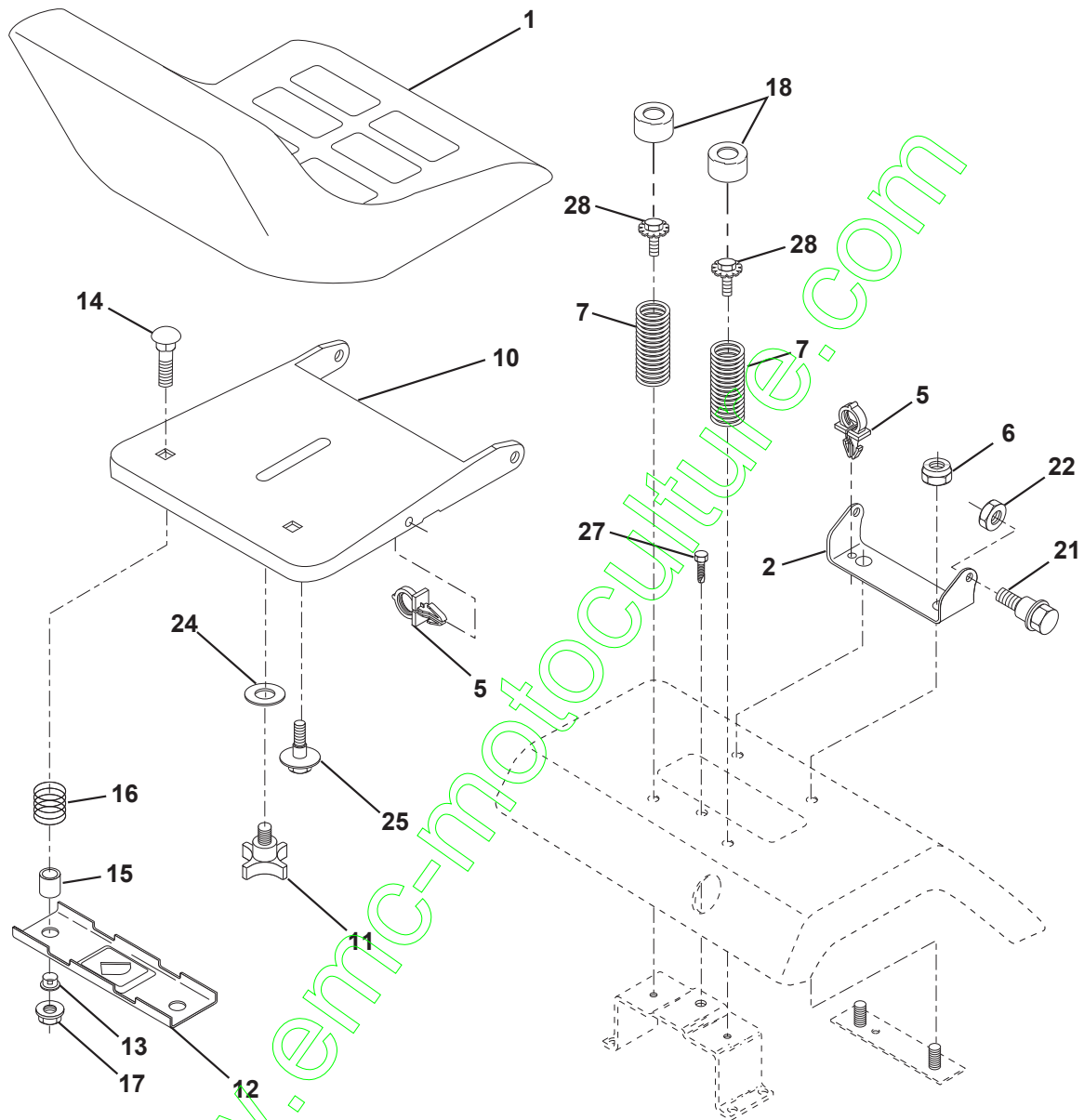

KEY NO.	PART NO.	DESCRIPTION
1	532140840	Seat
2	532140551	Pivot Bracket, Seat
5	532145006	Clip, Push-in Hinged
6	873800600	Nut, Lock Hex w/Ins 3/8-16 UNC
7	532124181	Spring, Seat
10	532155925	Pan, Seat
11	532120068	Knob, Seat, Black 1/2-13 UNC
12	532121246	Bracket, Switch Mounting
13	532121248	Bushing, Snap, Black, Nylon
14	872050412	Bolt, Carriage 1/4-20 x 1-1/2
15	532121249	Spacer, Split .28 x .96
16	532123740	Spring

KEY NO.	PART NO.	DESCRIPTION
17	532123976	Locknut, Flange 1/4 Grade 5
18	532124238	Cap Spring Seat Blk 1.75 x 1.0
21	532153236	Bolt, Shoulder 5/16-18 Unc -2A
22	873680500	Nut, Crownlock 5/16-18
24	819171912	Washer 17/32 x 1-3/16 x 12 Gauge
25	532127018	Bolt, Shoulder 5/16-18 x .62
27	817490608	Screw Thdrol 3/8-16 x 3/4
28	532150176	Bolt 5/16-18 UNC x 3/4 w/Sems

**NOTE:** All component dimensions given in U.S. inches  
1 inch = 25.4 mm

# REPAIR PARTS

TRACTOR - MODEL NO. GTVH200 (954140016A), PRODUCT NO. 954 14 00-16

## DECALS

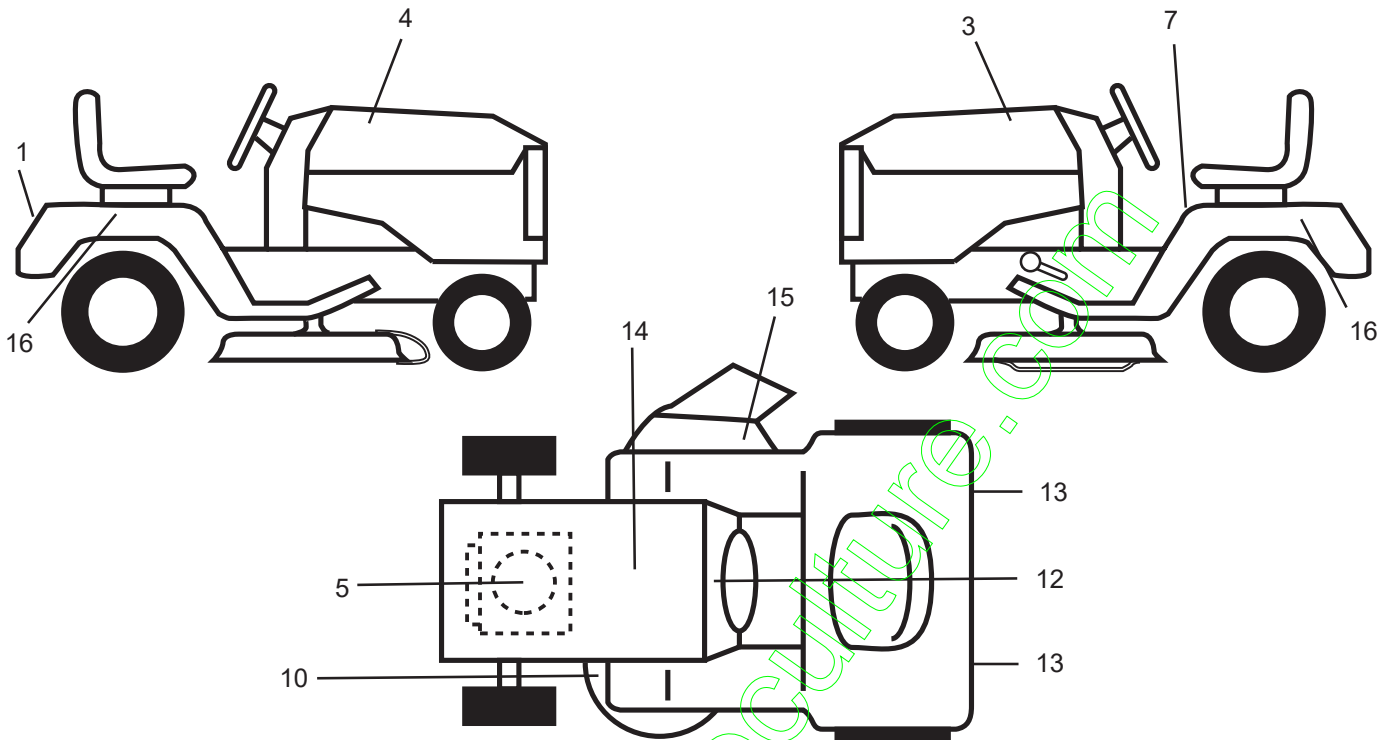

KEY NO.	PART NO.	DESCRIPTION	KEY NO.	PART NO.	DESCRIPTION
1	532150617	Decal, Fender	14	532145005	Decal, Btry Dngr/Psn
3	532166321	Decal, Hood LH	15	532137259	Decal, Warning Multi-Language
4	532166319	Decal, Hood RH	16	532155862	Decal, Fender Automatic
5	532166323	Decal, HP Engine	--	532142341	Decal, Drawbar Cntrl Mvt
7	532157140	Decal, Danger Fender English/ French	--	532157199	Pad, Footrest
10	532160397	Decal, V-Belt Sch	--	532138311	Decal, Handle Lft Height Adjust
12	532156993	Decal, Saddle Oper Instr.	--	532166366	Manual, Owner's (English)
13	532106202	Reflector Taillight	--	532166367	Manual, Owner's (French)

## WHEELS & TIRES

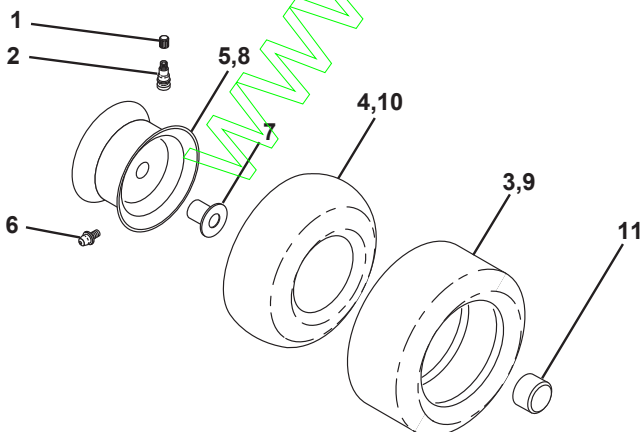

KEY NO.	PART NO.	DESCRIPTION
1	532059192	Cap Valve Tire
2	532065139	Stem Valve
3	532106222	Tire F
4	532059904	Tube Front (Service Item Only)
5	532138336	Rim Asm 6" front
6	532124957	Fitting Grease (Front Wheel Only)
7	532124959	Bearing Flange (Front Wheel Only)
8	532164127	Rim Asm 12" rear
9	532124106	Tire Rear
10	532007154	Tube Rear (Service Item Only)
11	532104757	Cap Axle Blk 1 50 X 1 00
--	532144334	Sealant, Tire (1 Doz. Tube)

**NOTE:** All component dimensions given in U.S. inches  
1 inch = 25.4 mm

# REPAIR PARTS

TRACTOR - MODEL NO. GTVH200 (954140016A), PRODUCT NO. 954 14 00-16  
HYDRO GEAR TRANSAXLE - MODEL NUMBER 314-3000

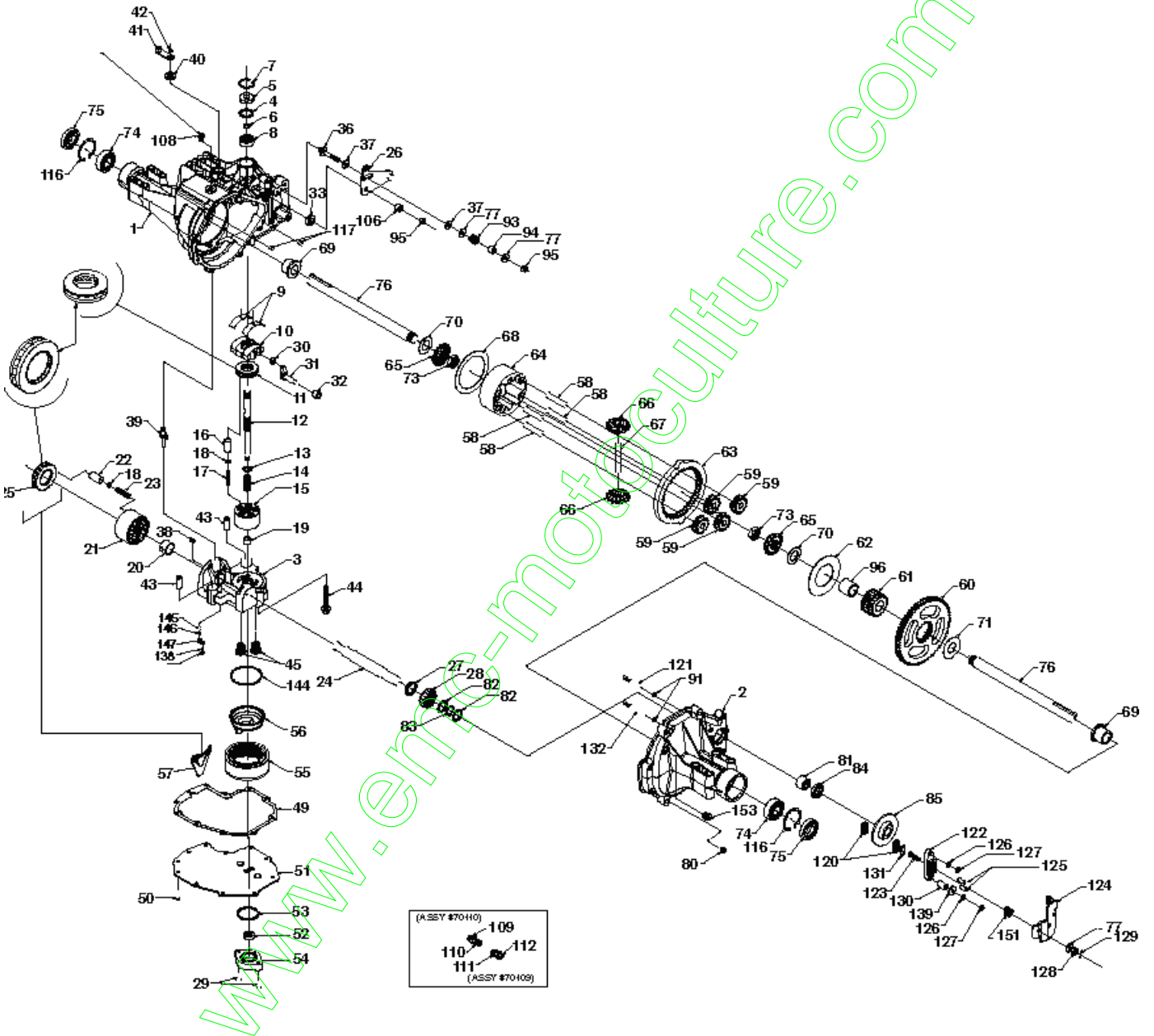

# REPAIR PARTS

TRACTOR - MODEL NO. GTVH200 (954140016A), PRODUCT NO. 954 14 00-16

HYDRO GEAR TRANSAXLE - MODEL NUMBER 314-3000

KEY PART NO.	NO.	DESCRIPTION	KEY PART NO.	NO.	DESCRIPTION
1	532161122	Main housing assembly	64	532161149	Planetary carrier
2	532161123	RH housing assembly	65	532161150	Miter gear, diff. (splined)
3	532161124	Center section assembly	66	532161151	Miter gear, diff.
4	532161125	Spacer	67	532161152	Shaft, differential
5	532142932	Seal-lip	68	532161153	Diff. thrust plate
6	532142928	Wire retaining ring	70	532161154	Washer
7	532142933	Retaining ring	71	532161155	Washer
8	532142934	Ball bearing	73	532161156	Hex jam nut, 5/8-18
9	532142935	Cradle bearing	75	532161157	Seal, 1" ID x 2.0472 x 0.375
10	532142937	Variable swashplate	76	532161158	Shaft, axle
11	532150771	Thrust bearing 30 x 52 x 13	77	532142884	Washer
12	532161126	Input shaft	79	532150801	Gasket material
13	532142978	Block thrust washer	80	532161159	Torx head screw, 5/16-18
14	532142977	Block spring	81	532161160	Needle bearing (SCE1412)
15	532142938	10cc cylinder block assembly	82	532161161	Washer
21	532142944	10cc cylinder block assembly	83	532161162	Retaining ring
24	532161127	Output (motor) shaft	84	532161163	Lip seal (.8751.D. x 1.30.D. x.25)
25	532150773	Thrust bearing 42 x 68 x 16	85	532161164	Brake disk
26	532161128	Control arm	93	532142969	Spring, friction pack
27	532161129	Spacer	94	532142980	Spacer, friction pack
28	532161130	16t pinion gear	95	532142957	Hex lock nut 5/16-24
29	532161131	Cap screw, M6 x 1-22	96	532161165	Sleeve bearing
30	532142941	Slot guide	97	532150798	Oil
31	532161132	Trunnion arm	106	532161166	Spacer, trunnion
32	532161133	Trunnion bushing	109	532142918	Fitting-O ring assembly
33	532142940	Lip seal	111	532142917	Cap-vent assembly
36	532161134	5/16-24 stud	116	532161167	Retaining ring
37	532142967	Puck, friction	117	532161168	Std hdls pin
38	532150787	Bypass plate	120	532142883	Puck, brake
39	532142946	Bypass actuator	122	532161169	Brake yoke
40	532142945	Lip seal	123	532161170	Bolt, square head
41	532142952	Bypass arm	124	532161171	Arm, brake
42	532142953	Retaining ring	125	532142887	Pins, brake
43	532142965	Pin	126	532161172	Lockwasher, 1/4
44	532150797	Screw	127	532161173	Nut, 1/4-20
49	532161135	Gasket, lower	128	532142885	Nut, castle
50	532161136	Screw-self tapping	129	532142886	Cotter pin
51	532161137	Lower cover	130	532161174	Spacer
52	532161138	Gerotor assembly	131	532142882	Puck plate
53	532144581	O-ring	138	532161175	Screw
54	532161139	Gerotor cover	139	532161176	Washer, 7/80D x .2651D x .125 THK
55	532161140	Filter	144	532161177	O ring, 2.864 ID 0.070 THK
56	532161141	Charge manifold	145	532161178	Charge relief spring
57	532161142	Retainer, motor bearing	146	532161179	Ball
58	532161143	Pin, carrier	147	532161180	Plate, relief
59	532161144	15t planet gear	151	532161181	Comp. spring, brake anti-drag
60	532161145	67t spur gear	153	532142914	Plug, straight thread
61	532161146	21 tooth sun gear			
62	532161147	Planet thrust plate			
63	532161148	51t ring gear			

**NOTE:** All component dimensions given in U.S. inches  
1 inch = 25.4 mm