

ICT16A

Spare parts
Ersatzteile
Pièces détachées
Reserve onderdelen
Repuestos
Reservdelar

www.emc-motoculture.com

REPAIR PARTS

TRACTOR- -MODEL NO. ICT16A (JICTH16E) PRODUCT NO. 954 13 00-42
ELECTRICAL

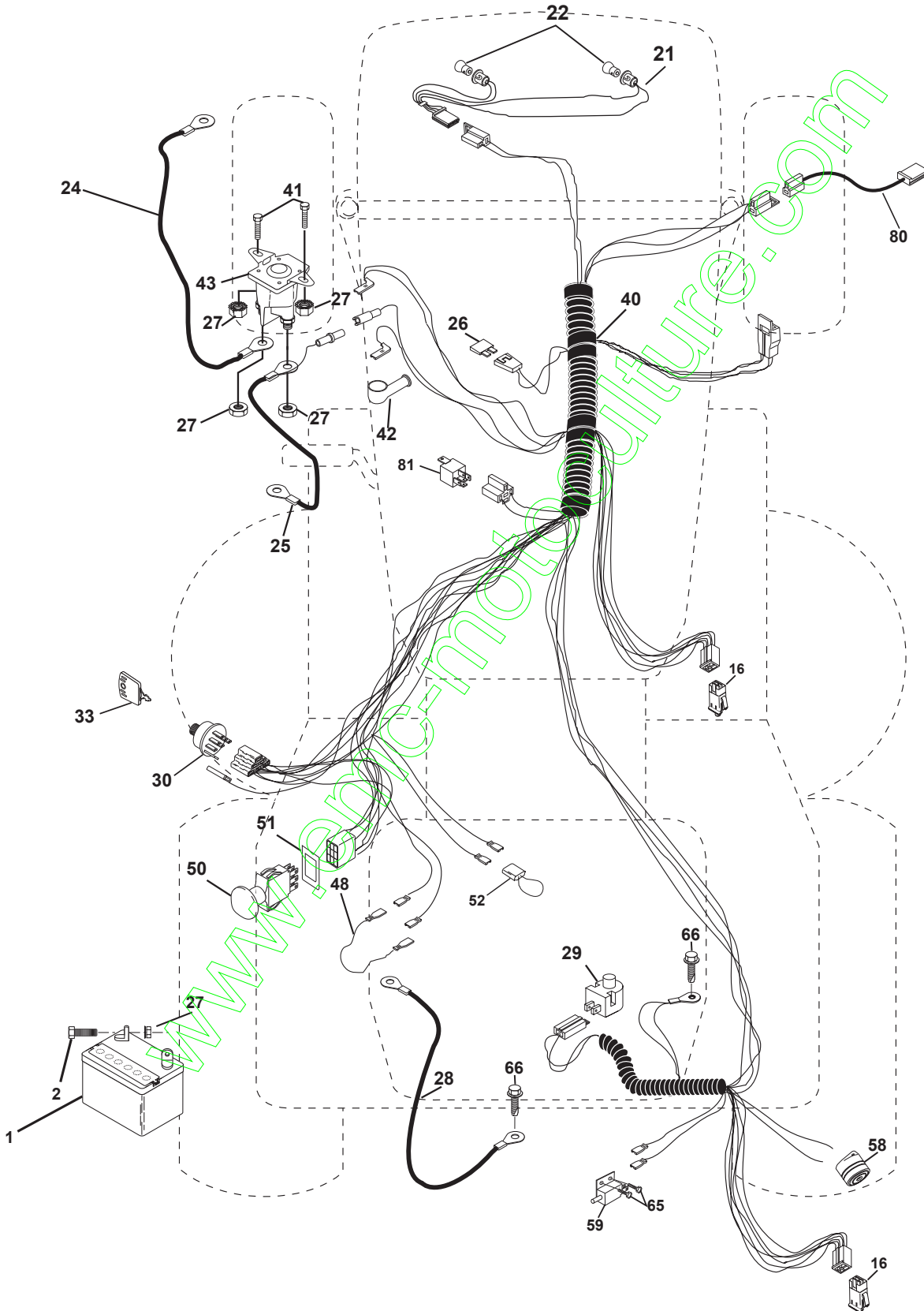

REPAIR PARTS

TRACTOR- -MODEL NO. ICT16A (JICTH16E) PRODUCT NO. 954 13 00-42
ELECTRICAL

KEY NO.	PART NO.	DESCRIPTION
1	532144925	Battery 12 Volt 25 AMP Wet
2	874760412	Bolt Hex Hd 1/4-20 Unc X 3/4
16	532153664	Switch Interlock Push-In
21	532166182	Harness Asm Light W/4152J
22	532004152	Bulb Light #1156
24	532124780	Cable Starter 6Ga 11" Red
25	532165987	Cable Battery Crd 56" Red
26	532166180	Fuse 15 Amp
27	873510400	Nut Keps Hex 1/4-20 Unc
28	532127725	Cable Ground 6Ga 18" Black
29	532160784	Switch Plunger Normal Op Olive
30	532163968	Switch Ignition
33	532140401	Key Ign Molded
40	532170214	Harness Ign Crd Elect
41	871110408	Bolt Flk Fin Hex 1/4-20 Unc X 1/2
42	532131563	Cover Terminal Red
43	532145673	Solenoid
48	532140844	Adapter Ammeter Rectangular
50	532169417	Switch PTO 3PDT Delta
51	532140405	Ring Retainer PTO
52	532141940	Protection Wire Loop
58	532169419	Buzzer Crd
59	532166299	Switch FBI CRD
65	817211008	Screw Slftp #10-16 x 1/2 Ty-Ab
66	817490608	Screw Thdrol 3/8-16 x 1/2 Ty-Tt
80	532146685	Harness Clutch EVX
81	532109748	Relay Asm

NOTE: All component dimensions given in U.S. inches.
1 inch = 25.4 mm.

REPAIR PARTS

TRACTOR- -MODEL NO. ICT16A (JICTH16E) PRODUCT NO. 954 13 00-42
CHASSIS AND ENCLOSURES

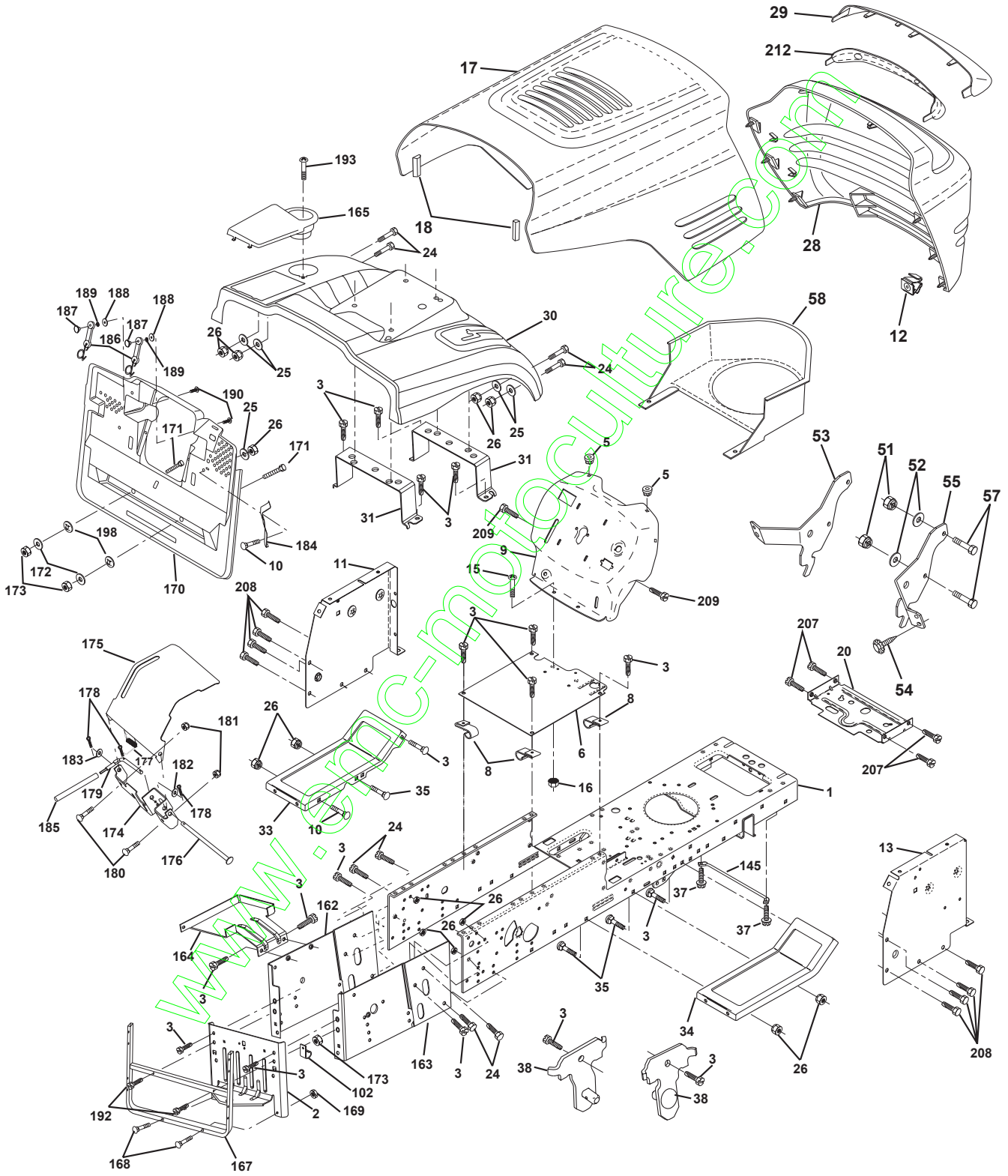

REPAIR PARTS

TRACTOR- -MODEL NO. ICT16A (JICTH16E) PRODUCT NO. 954 13 00-42 CHASSIS AND ENCLOSURES

KEY NO.	PART NO.	DESCRIPTION	KEY NO.	PART NO.	DESCRIPTION
1	532169831	Chassis Stamping	162	532165672	Bracket Exten Chassis Lh CRD
2	532165606	Drawbar	163	532165673	Bracket Exten Chassis Rh CRD
3	817060612	Screw 3/8-16 x .75	164	532165605	Support Battery CRD
5	532155272	Bumper Hood/Dash	165	532168407	Cover Battery CRD Lt
6	532155923	Saddle	167	532165779	Support Asm. Backplate WLDMNT
8	532126471	Clip Insulator 13/32 Mtg. Hole	168	872050412	Bolt, RDHD SHT NK 1/4-20 x 1-1/2
9	532172099	Dash	169	532123976	Nut, Lock 1/4 LGE FLG Gr. 5 Zinc
10	872140608	Bolt, Carriage 3/8-16 x 3/4	170	532165607	Cover, Backplate Plastic Black
11	532155927	Panel, Dash, L.H.	171	874520640	Bolt Rdhd Sqnk 3/8-16 x 2-1/2 G 5
12	532145660	Clip Tinnerman Grille P/L	172	819132016	Washer 13/32 x 1-1/4 x 16 Ga.
13	532172108	Panel, Asm. Dash R.H.	173	873510600	Nut, Keps Hex 3/8-16 UNC
15	874180512	Screw, Machine, Truss Head 5/16-18 UNC x 3/4	174	532165939	Bracket Switch FBI CRD
16	873510500	Nut	175	532166212	Guard Door Rear CRD
17	532150760	Hood Assembly	176	532128600	Pin Hinge Pivot
18	532126938	Bumper Hood	177	532132796	Spring Bagger Top LH Black
20	532156437	Plate Mtg. Battery/Fuel Tank	178	876020312	Pin Cotter 3/32 x 3/4 Cad Zinc
24	874780616	Bolt	179	532165942	Rod Pivot FBI CRD
25	819131312	Washer 13/32 x 13/16 x 12 Gauge	180	874760516	Bolt Hex HD 5/16-18 UNC x 1
26	873800600	Nut	181	873680500	Nut Crownlock 5/16-18
28	532169509	Grille/Lens Asm	182	532138200	Washer .385 x .625 x 11 Ga.
29	532166603	Lens, Grille	183	819131316	Washer 13/32 x 13/16 x 16 Ga.
30	532168872	Fender	184	532166139	Bracket Actuator Bagger CRD
31	532165156	Bracket, Fender Support	185	532165940	Tube Lever Switch FBI CRD
33	532149139	Footrest, L.H.	186	532160793	Latch Asm Multch Bagger
34	532149140	Footrest, R.H.	187	532125004	Nut Weld .327/.304 #10-24
35	872110606	Bolt	188	819061216	Washer #10
37	817490508	Screw Thdrol 5/16-18 x 1/2 TYT	189	810071000	Washer Lock #10
38	532169834	Bracket Asm Pivot Mower Rear	190	871161010	Screw Truss Hd Phil 10-24 x 5/8
51	873800400	Nut Lock w/Insert 1/4-20 UNC	192	817490624	Screw Thdrol 3/8-16 x 1-1/2
52	819091416	Washer 9/32 x 7/8 x 16 Ga.	193	817070412	Screw Truss 1/4-20 x 3/4
53	532145201	Bracket Grille Pick off Lh	198	532168937	Nut, Push
54	532161464	Screw Hex Ws Hd 8-18 x 7/8	207	817670508	Screw Thdrol 5/16-18 x 1/2
55	532145202	Bracket Grille Pick off Rh	208	817670608	Screw Thdrol 3/8-16 x 1/2
57	874780412	Bolt, Fin Hex 1/4-20 UNC x .75	209	817000612	Screw Hex Wsh Thdrol 3/8-16
58	532162266	Duct Intake Air	212	532165919	Insert Lens Reflective
102	532124996	Clip Fuel Line 13/32 Mtg Hole	--	532005479	Button Plug
145	532156524	Rod Pivot Chassis/Hood			

NOTE: All component dimensions given in U.S. inches.
1 inch = 25.4 mm.

REPAIR PARTS

TRACTOR- -MODEL NO. ICT16A (JICTH16E) PRODUCT NO. 954 13 00-42
DRIVE

KEY NO.	PART NO.	DESCRIPTION	KEY NO.	PART NO.	DESCRIPTION
1	-----	Transaxle, Hydro Gear 331-0650 (Order parts from transaxle manufacturer)	81	532165585	Asm, Shaft
3	532143995	Pulley Hydro 0650 Lt/CRD	82	532123782	Spring, Torsion
8	532165619	Rod, Shift Fender Adjust Lt	83	819171216	Washer 17/32 x 3/4 x 16 Ga.
9	532169992	Clutch Ele	84	532165629	Link, Transaxle
10	876020416	Pin, Cotter 1/8 x 1	94	532140462	Fan 7"
14	810040400	Washer, Lock Hvy Helical	95	532165935	Control Asm Bypass Hydro
16	873800500	Nut, Lock Hex w/Ins 5/16-18 UNC	96	532124788	Spring, Retainer 1"
18	874780616	Bolt Hex 3/8-16 UNC x 1 Gr.5	102	532141322	Washer, Bellville .50ID x 1.50D
20	532150280	Bolt, Hex 7/16-20 x 4-1/4 5 Ga 1.38	103	873940800	Nut, Hex Jam Toplock 1/2-20 UNF
21	532130564	Knob Deluxe 1/2-13 Unc	104	532140156	Arm, Control Hydro
22	532165688	Rod, Brake CRD 0650	105	871070516	Screw Cap Hex 5/16 x 18 Unc-1
23	532170171	Bracket asm Clutch	144	819111016	Washer 11/32 x 5/8 x 16 Ga.
24	873350600	Nut	145	874490540	Bolt Hex FGHD 5/16-18 x Gr 5
25	532106888	Spring, Rod, Brake	146	874490536	Bolt Hex FLGHD 5/16-18 x 2-1/4
26	819131316	Washer 13/32 x 13/16 x 16 Ga.	147	874490524	Bolt Hex FLGHD 5/16-18 x 1-1/2
27	876020412	Pin, Cotter 1/8 x 3/4	150	532165850	Bushing, Bellcrank Grnd Dr
28	532145204	Rod, Parking Brake	151	819133210	Washer 13/32 x 2 x 10 Ga.
29	532071673	Cap, Parking Brake	153	874760516	Bolt Hex Hd 5/16-18 Unc x 1
30	532169592	Bracket, Mfg. Transaxle	156	532166002	Washer Srrted 5/16ID x 1.125
32	874760512	Bolt Hex 5/16-18 UNC x 3/4	157	532153236	Bolt Shoulder 5/16-18 Unc 2A
33	872140506	Bolt Rdhd Sqnk 5/16-18 Unc x 3/4	158	532165589	Bracket Shift Mount
34	532165496	Shaft, Asm Pedal Foot CRD	159	532165494	Hub Tapered Flange Shift Lt
35	532120183	Bearing, Nylon	160	819292016	Washer 29/32 x 1-1/4 x 16 Ga.
36	819211616	Washer 21/32 x 1 x 16 Ga.	161	872140406	Bolt Rdhd Sqnk 1/4-20 x 3/4 Gr 5
37	532124963	Pin, Roll 3/16 x 1"	162	873680400	Nut Crownlock 1/4-20 Unc
38	532165936	Pulley Flat Composite	163	874780416	Bolt Hex Fin 1/4-20 Unc x 1 Gr 5
39	874760644	Bolt Fin Hex 3/8-16 UNC x 2-3/4	164	819091010	Washer 5/8 x .281 x 10 Ga.
40	532124965	Spacer, Split 395 x 59 Bzp	165	532165623	Bracket Pivot Lever
42	819131312	Washer 13/32 x 13/16 x 12 Ga.	166	532166880	Screw 5/16-18 x 5/8
47	532127783	Pulley, Idler, V Groove Plastic	167	532165588	Bracket Support Shift CRD
48	532154407	Bellcrank Clutch Grnd Dr	168	532165492	Bolt Shoulder 5/16-18 x .561
49	532123205	Retainer, Belt Style Spring	169	532165580	Plate Fastening Lt
50	874760624	Bolt Hex Hd 3/8-16 UNC x 1-1/2	171	817490608	Screw Thdrol 3/8-16 x 1/2 Ty-Tt
51	873680600	Nut, Crownlock 3/8-16 UNC	172	532165587	Shaft Asm Shifter Frt CRD 0650
52	873680500	Nut Crownlock 5/16-18	173	532165934	Bracket Hydro Bypass CRD
53	532105710	Link, Clutch 7.66	174	810090400	Washer Lock 1/4
55	532105709	Spring, Return, Clutch	175	532165931	Spring Bypass CRD
56	874760620	Bolt, Hex 3/8-16 UNC x 1-1/4	176	819070816	Washer 7/32 x 1/2 x 16 Ga.
57	531008021	V-Belt Key 1 1/2" 0650 CRD	177	532165932	Keeper Flat Idler 3.06" CRD
61	817060612	Screw 3/8-16 x 3/4	178	532165933	Keeper Belt Idler 1.88" CRD
62	532124872	Cover, Pedal	179	532120958	Washer Sintered
63	532145868	Pulley, Clutch elect EVX 1"	180	532165630	Pulley, Idler, Flat 1.88"CRD
65	810040700	Washer	181	532165797	Bracket Idler Ground Drive CRD
66	532154778	Keeper, Belt Engine F-Proof	182	532165634	Keeper Belt 2.5" Od V-Idler CRD
71	532140158	Strap, Torque, Lh	183	532165626	Pulley V-Idler 2.50" Od CRD
73	532156347	Strap, Torque, Rh	184	817490644	Screw Hexwsh Thdrol 3/8-16 x 2-3/4
74	532121199	Spacer, Split	185	532165541	Link Shift CRD Hydro 0650
75	532121749	Washer 25/32 x 1-1/4 x 16 Ga.	186	532165614	Hub Tapered Round CRD
76	812000001	Ring, E	187	817490620	Screw Thdrol 3/8-16 x 1-1/4 TT
77	532123583	Key, Square	188	532110436	Bushing Snap Split Blk
78	532121748	Washer 25/32 x 1-5/8 x 16 Ga.	202	872110612	Bolt Carr Sh 3/8-16 x 1-1/2 Gr. 5

NOTE: All component dimensions given in U.S. inches
1 inch = 25.4 mm

REPAIR PARTS

TRACTOR- -MODEL NO. ICT16A (JICTH16E) PRODUCT NO. 954 13 00-42
STEERING ASSEMBLY

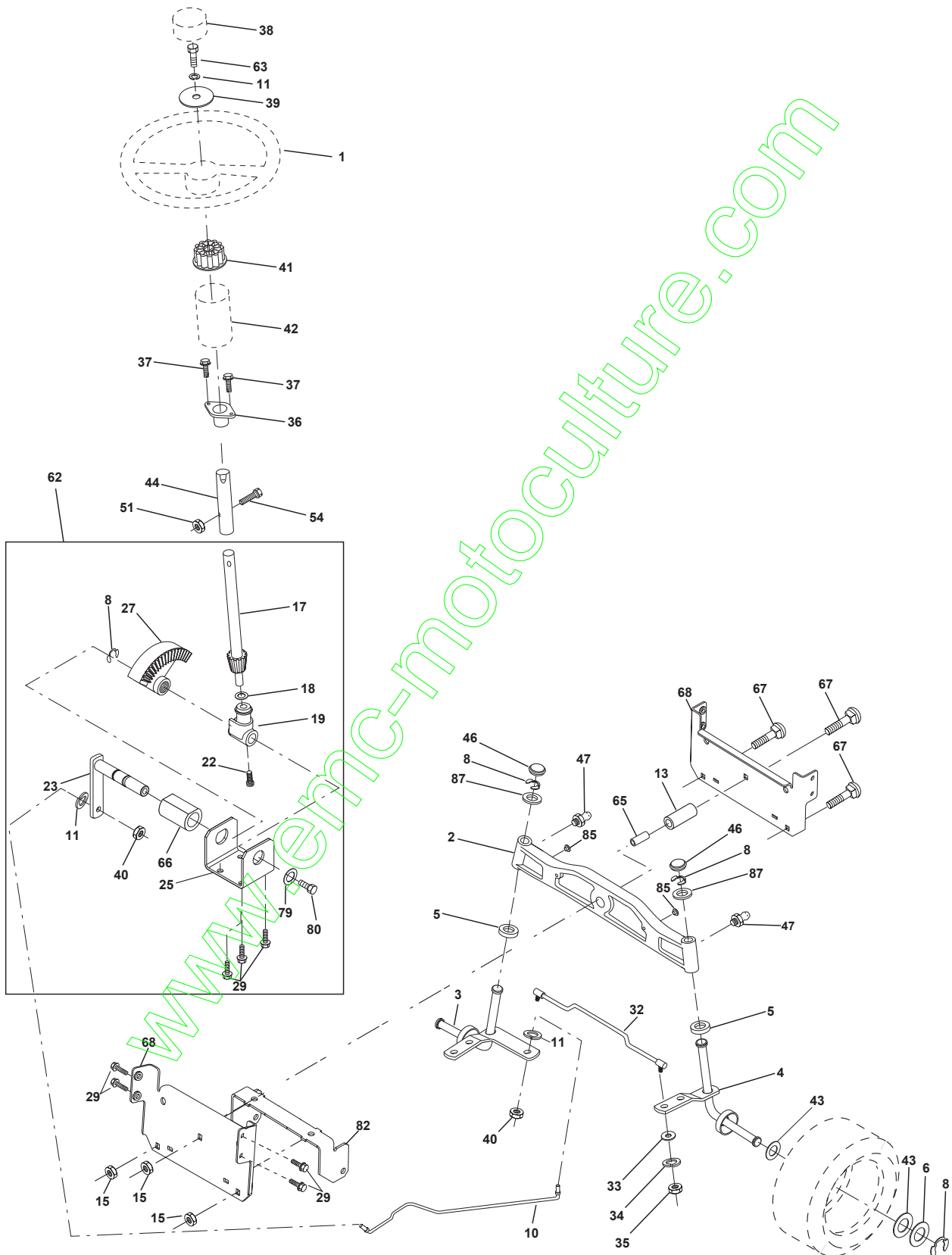

REPAIR PARTS

TRACTOR- -MODEL NO. ICT16A (JICTH16E) PRODUCT NO. 954 13 00-42
STEERING ASSEMBLY

KEY NO.	PART NO.	DESCRIPTION
1	532172092	Steering Wheel
2	532165854	Axle Cast Lt Machined
3	532169840	Spindle Assembly, L.H.
4	532169839	Spindle Assembly, R.H.
5	532124931	Bearing, Race, Thrust, Hardened
6	532121748	Washer 25/32 x 1-5/8 x 16 Gauge
8	812000029	Ring, Klip
10	532169832	Link, Drag
11	810040600	Washer, Lock
13	532136518	Spacer Brg Axle Front
15	532145212	Nut Hex Flange Lock
17	532156546	Shaft Assembly, Steering
18	532057079	Washer, Thrust .515 x .750 x .033
19	532160395	Support, Shaft
22	532165857	Screw Hex Wshhd Torx
23	532165851	Pittman Shaft Assembly
25	532154406	Bracket, Steering
27	532136874	Gear, Sector
29	817060612	Screw 3/8-16 x 3/4
32	532170162	Rod, Tie
33	819111216	Washer 11/32 x 3/4 x 16 Ga.
34	810040500	Washer, Lock Hvy Hlcl 5/16
35	873810500	Nut Lock 5/16-24
36	532155099	Bushing, Steering
37	532152927	Screw TT #10-32 x 5 x 3/8 Flange
38	532172093	Cap Wheel Steering
39	819132411	Washer 13/32 x 1-1/20 x 11 Gauge
40	532124701	Nut Lock Center 3/8-24 Unf
41	532159945	Adaptor, Steering Wheel
42	532169633	Boot, Steering
43	532121749	Washer 25/32 x 1-1/4 x 16 Gauge
44	532153720	Extension Steering Non-Adjust
46	532121232	Cap, Spindle
47	532124836	Fitting, Grease
51	873800500	Nut Lock Hx W/Ins 5/16-18 UNC
54	874780520	Bolt Fin Hex 5/16-18 UNC x 1-1/4
62	532167902	Kit, Steering Assembly, Service
63	874780616	Bolt Fin Hex 3/8-16 unc. x 1 Gr. 5
65	532160367	Spacer Brace Axle
66	532154404	Bearing Arm Pittman
67	872140618	Bolt Rdhd Sq 3/8-16 x 2-1/4
68	532169827	Brace Axle
79	819132012	Washer 13/32 x 1-1/4 x 12 Ga
80	874950612	Bolt Hex Nylon 3/8-16 x 3/4
82	532169835	Bracket Susp Chassis Front
85	532133835	Fastner Christmas Tree
87	532173966	Washer Flat .781 x 1-1/2 x .14

NOTE: All component dimensions given in U.S. inches.
1 inch = 25.4 mm.

REPAIR PARTS

TRACTOR- -MODEL NO. ICT16A (JICTH16E) PRODUCT NO. 954 13 00-42
SEAT ASSEMBLY

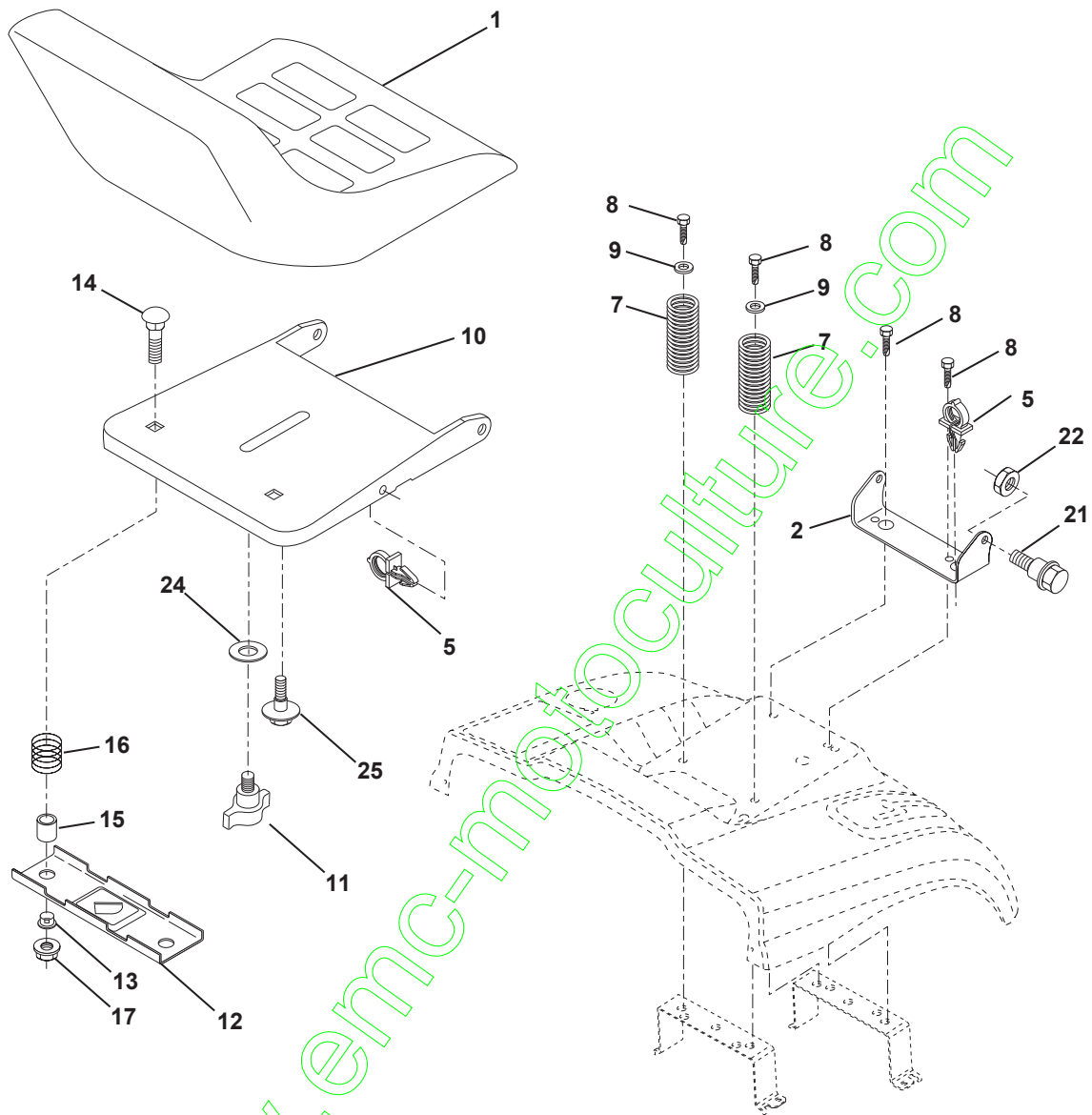

KEY NO.	PART NO.	DESCRIPTION
1	532140118	Seat
2	532140551	Bracket Pnt Pivot Seat (blk)
5	532145006	Clip Push In Hinged
7	532124181	Spring Seat Cprsn 2 250 Blk Zi
8	817000616	Screw 3/8-16 X 1-1/2
9	819131614	Washer 13/32 X 1 X 14 Ga
10	532155925	Pan Pnt Seat (blk)
11	532166369	Knob Seat Adj. Wingnut
12	532121246	Bracket Pnt Mounting Switch

KEY NO.	PART NO.	DESCRIPTION
13	532121248	Bushing Snap Blk Nyl 50 Id
14	872050412	Bolt Rdhd Sht Nk 1/4-20x1-1/2
15	532121249	Spacer Split 28 X 88 Zinc
16	532123740	Spring Cprsn
17	532123976	Nut Lock 1/4 Lge Flg Gr 5 Zinc
21	532171852	Bolt Shoulder 5/16-18 Unc-2A
22	873800500	Nut Hex Lock w/lns 5/16-18
24	819171912	Washer 17/32 X 1-3/16 X 12 Ga.
25	532127018	Bolt Shoulder 5/16-18 X 62

NOTE: All component dimensions given in U.S. inches.
1 inch = 25.4 mm

REPAIR PARTS

TRACTOR- -MODEL NO. ICT16A (JICTH16E) PRODUCT NO. 954 13 00-42

DECALS

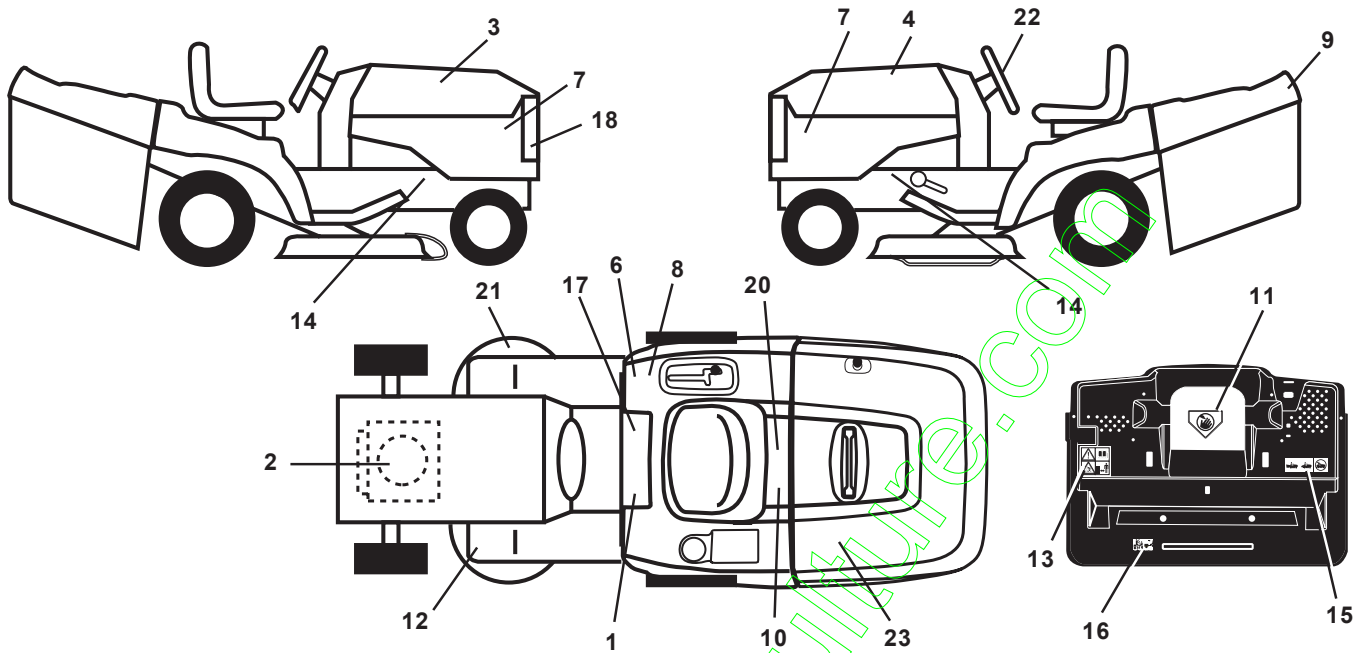

KEY NO.	PART NO.	DESCRIPTION
1	532145498	Decal Read Owner's Manual Sym
2	532168892	Decal Hp Engine
3	532170533	Decal Hood Rh
4	532170534	Decal Hood Lh
6	532126187	Decal 100 DBA
7	532162927	Decal Hood Insert
8	532145437	Decal Europe Stand Ce
9	532141761	Decal Fender Logo
10	532145005	Decal Bat Dan/Poi P/L Sym Wpn
11	532145494	Decal Mower Cut Finger Symbol
12	532159737	Decal Brake/Clutch Symbol Lt
13	532166959	Decal Warn Back Plate CRD
14	532159736	Decal Chassis Hot Muffler

KEY NO.	PART NO.	DESCRIPTION
15	532166961	Decal Oper Bag Presence CRD
16	532162598	Decal Drawbar Load Limit
17	532140837	Decal Saddle Brake Parking
18	532152262	Decal Grille
20	532166960	Decal Bypass Fender CRD
21	532166286	Decal Hex Belt Sch 92 CRD
22	532170565	Decal Ins Strg Whl
23	532170654	Decal Bagger Top CRD
—	532138311	Decal Lift Handle
—	532171237	Pad Footrest
—	532174177	Manual Operator's (Euro)
—	532174178	Manual Operator's (Scan)

WHEELS & TIRES

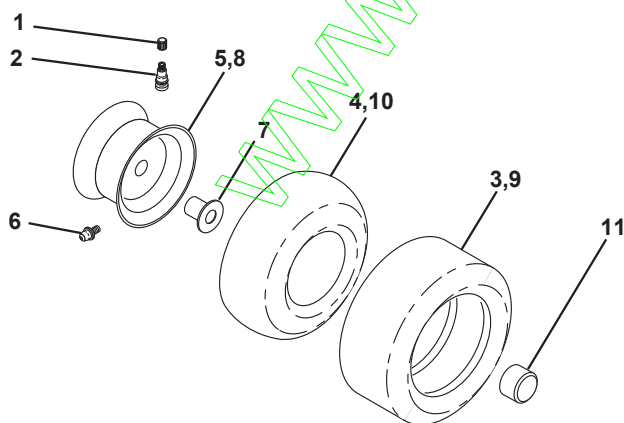

KEY NO.	PART NO.	DESCRIPTION
1	532059192	Cap Value Tire
2	532065139	Stem Value
3	532106222	Tire F Ts 15 X 6 0 - 6 Service
4	532059904	Tube Inner Front #35060
5	532138336	Rim Asm 6"front Silver Service
6	532124957	Fitting Grease
7	532124959	Bearing Flange
8	532138337	Rim Asm 8"rear Silver Service
9	532138468	Tire R Ts 20 x 8-8 Service
10	532124926	Tube Rear 9 5 X 8 Service
11	532104757	Cap Axle Blk 1 50 X 1 00
--	144334	Sealant, Tire (10 oz. tube)

NOTE: All component dimensions given in U.S. inches
1 inch = 25.4 mm

REPAIR PARTS

TRACTOR- -MODEL NO. ICT16A (JICTH16E) PRODUCT NO. 954 13 00-42
ENGINE

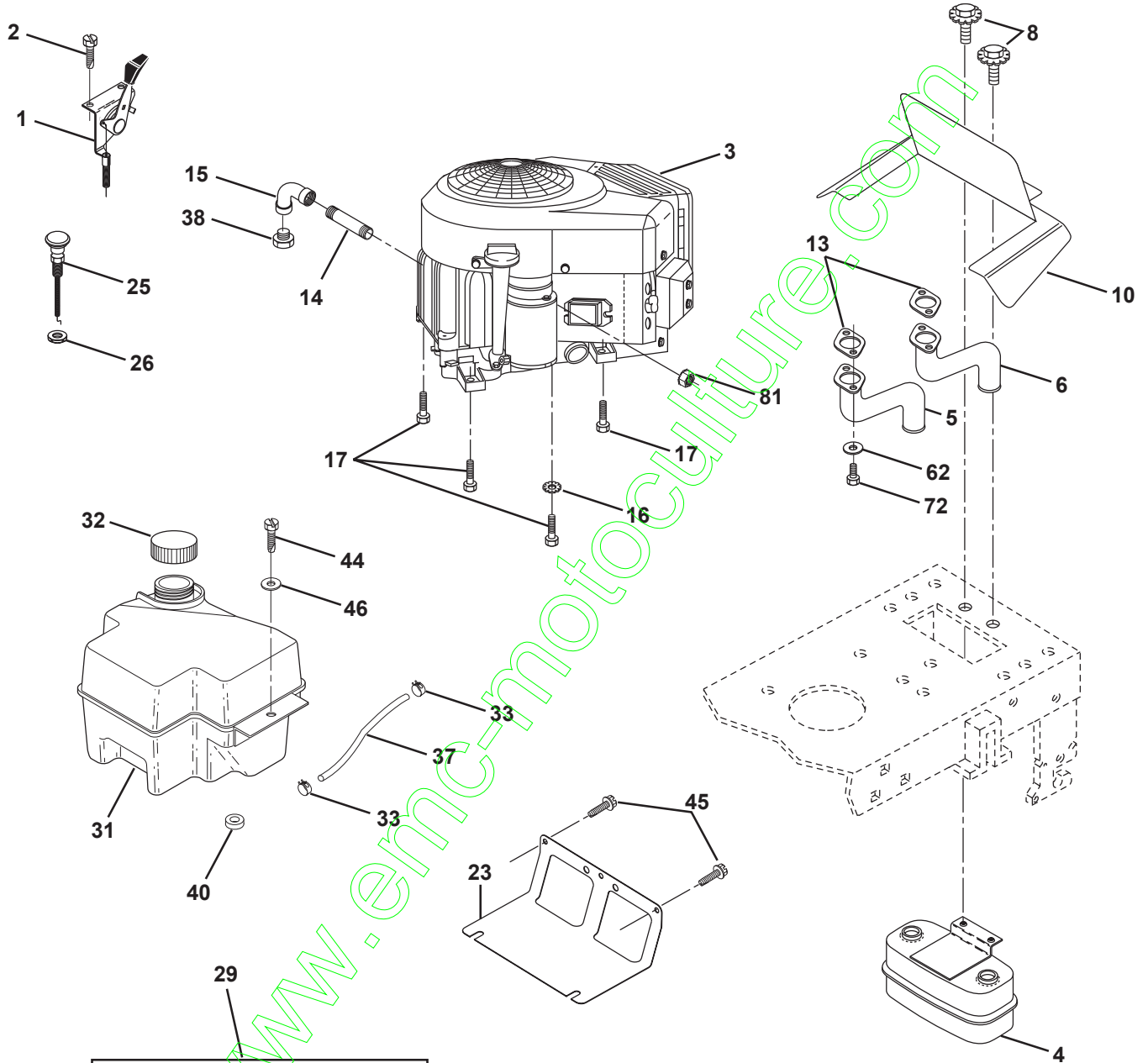

OPTIONAL EQUIPMENT
Spark Arrester

REPAIR PARTS

TRACTOR- -MODEL NO. ICT16A (JICTH16E) PRODUCT NO. 954 13 00-42
ENGINE

KEY NO.	PART NO.	DESCRIPTION
1	532148875	Control Throt
2	817720410	Screw Hex Thd Cut 1/4-20x5/8 T
3	-----	Engine Briggs Model 407777 (Order Parts from Engine Manufacturer)
4	532149723	Muffler Exhaust
5	532159955	Exhaust Asm. Left
6	532160589	Exhaust Asm. Right
8	532150176	Bolt 5/16-18unc x 3/4 w/sems
10	532162797	Shield Heat
13	532165391	Gasket Muffler
14	813280336	Nipple Pipe 4-12"
15	813200300	Elbow Std 90 Degree 3/8-18 Npt
16	811050600	Washer Lock Ext Tooth 3/8
17	817490624	Screw Thdrol 3/8-16 x 1-1/2 Tytt
23	532169837	Shield Brn/Dbr Guard
25	532145996	Control Choke
26	873920600	Nut Keps 3/8-24 UNF
29	532137180	Arrestor Spark
31	532161911	Tank Fuel Front 2.00
32	532140527	Cap Fuel
33	532123487	Clamp Hose Blk
37	532137040	Line Fuel
38	-----	Plug Oil Drain (Order from engine manufacturer)
40	532124028	Bushing Snap Nyl Blk Fuel Line
44	817670412	Screw Hex wsh Thdrol 1/4-20 x 3/4
45	817000612	Screw Hex Wsh Thdr 3/8-16 x 3/4
46	819091416	Washer 9/32 x 7/8 x 16 Ga.
62	810040500	Washer Lock Hvy HLCL Spr 5/16
72	871070512	Screw Hex Hd Cap 5/16-18 x 3/4
81	873510400	Nut Keps Hex 1/4-20 Unc

NOTE: All component dimensions given in U.S. inches
1 inch = 25.4 mm

REPAIR PARTS

TRACTOR- -MODEL NO. ICT16A (JICTH16E) PRODUCT NO. 954 13 00-42
MOWER LIFT

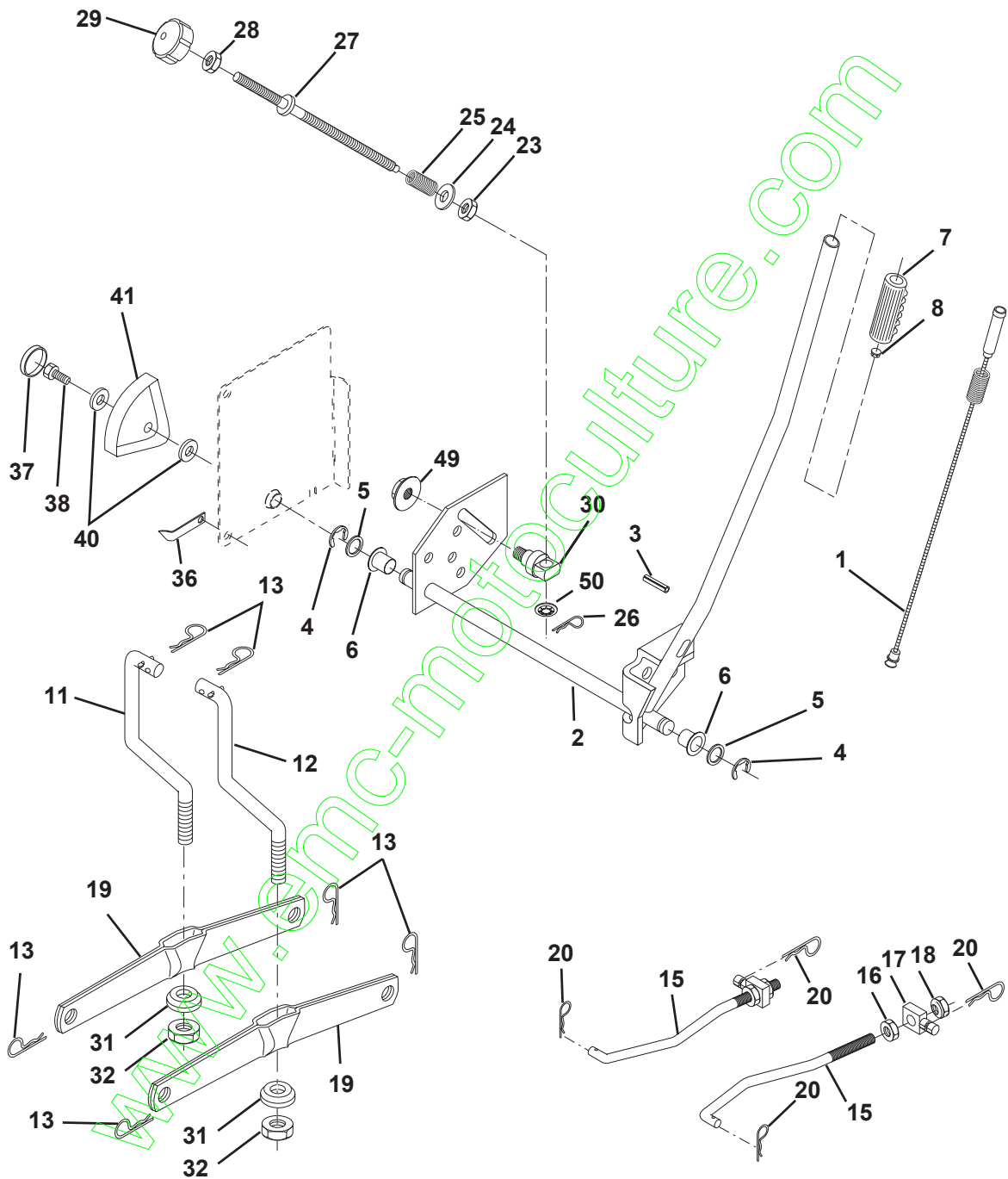

REPAIR PARTS

TRACTOR- -MODEL NO. ICT16A (JICTH16E) PRODUCT NO. 954 13 00-42
MOWER LIFT

KEY NO.	PART NO.	DESCRIPTION
1	532159460	Washer Asm Inner Spring W/Plunger
2	532159471	Shaft Asm. Lift
3	532105767	Pin Groove
4	812000002	E Ring #5133-62
5	819211621	Washer 21/32 x 1 x 21 Ga.
6	532120183	Bearing Nylon
7	532125631	Grip Handle Fluted
8	532124526	Button Plunger Black
11	532165829	Link Asm Lift L.H.
12	532165831	Link Asm Lift R.H.
13	532124670	Retainer Spring
15	532173288	Link Front
16	873350800	Nut Jam Hex 1/2-13 Unc
17	532130171	Trunnion Blk Zinc
18	873800800	Nut Lock w/Wsh 1/2-13 Unc
19	532139868	Arm Suspension Mower
20	532163552	Retainer Spring
23	532110807	Nut Special
24	819131016	Washer 13/32 x 5/8 x 16 Ga.
25	532124874	Spring 2-1/8"
26	532169484	Retainer Clip
27	532126971	Rod Adj Lift Zinc 7.49 Wrk Lg
28	873350600	Nut Hex Jam 3/8-16 Unc
29	532138057	Knob Inf 3/8-16 Unc Blk w/sym
30	532150233	Trunnion Infin Height
31	532169865	Bearing, Pvt. Lift.
32	873540600	Nut Crownlock 3/8-24
36	532155097	Pointer Height Indicator
37	532123935	Plug Hole Blk 1.485/1.515 Dia
38	817060516	Screw 5/16-18 x 1
40	819112410	Washer 11/32 x 1-1/2 x 10 Ga.
41	532123934	Scale Ind Height Blk
49	532145212	Nut hex Flange Lock
50	532110452	Nut Push Phos & Oil

NOTE: All component dimensions given in U.S. inches
1 inch = 25.4 mm

REPAIR PARTS

TRACTOR- -MODEL NO. ICT16A (JICTH16E) PRODUCT NO. 954 13 00-42
MOWER

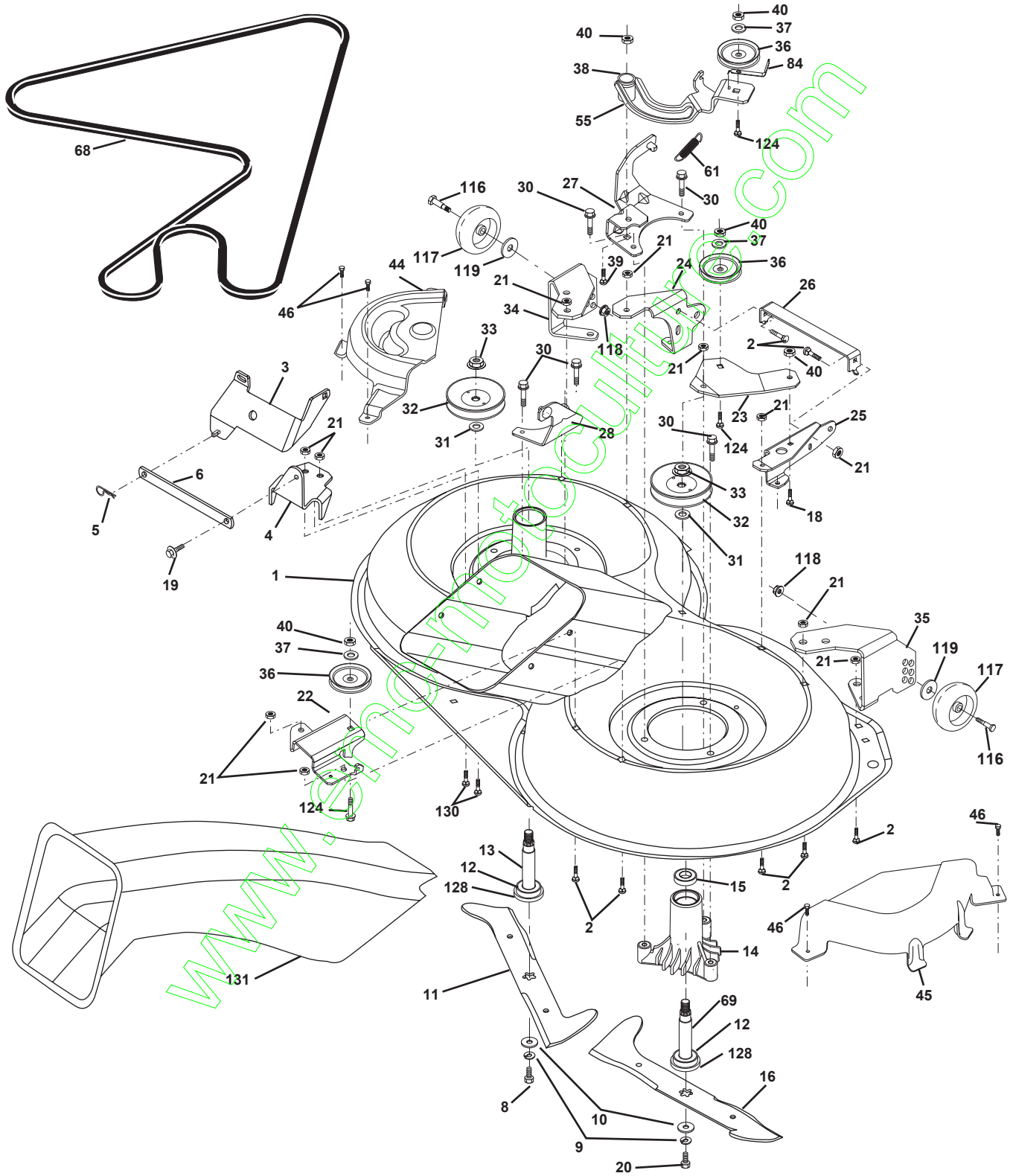

REPAIR PARTS

TRACTOR- -MODEL NO. ICT16A (JICTH16E) PRODUCT NO. 954 13 00-42
MOWER

KEY NO.	PART NO.	DESCRIPTION	KEY NO.	PART NO.	DESCRIPTION
1	532169160	Housing Asm. Mower	33	532137266	Nut Flg Top Lock Cntr B 9/16
2	872140506	Bolt Rdhd Sqnk 5/16-18 Unc x 3/4	34	532169174	Bracket Gauge Wheel Lf
3	532165569	Bracket Asm. S-Bar Chass	35	532169175	Bracket Gauge Wheel Rf
4	532169167	Bracket Bar Sway Deck	36	532146763	Pulley Idler V-Groove Dim 4.25
5	532124670	Retainer Spring	37	819131316	Washer 11/32 x 13/16 x 16 Ga
6	532165557	Bar Sway	38	532169851	Spacer Hub Arm Idler 107 CRD
8	532850857	Bolt 3/8-24 x 1.25 Gr8 Patched	39	872110622	Bolt Rdhd 3/8-16 Unc x 2-3/4 Gr. 5
9	810030600	Washer Lock Hvy 3/8 Unplated	40	873680600	Nut Crownlock 3/8-16 Unc
10	532140296	Washer Hard Blade Mower vented	44	532169180	Cover Mandrel Lh
11	532168720	Blade 3-1 Lh	45	532169179	Cover Mandrel Rh
12	532129895	Bearing Ball #6204 (Mandrel)	46	532137729	Screw Thd Roll 1/4-20 x 5/8
13	532137645	Shaft Asm. W/Lower Bearing	55	532169849	Arm Idler 107 CRD
14	532128774	Housing Mandrel Vented (Machd)	61	532165945	Spring Tension Belt
15	532110485	Bearing Ball Mandrel	68	532169178	Hex-Belt Mower
16	532168721	Blade 3-1 Rh	69	532165482	Shaft Asm W/Lwr Brg Rh Thd CRD
18	872110608	Bolt Rdhd Sqnk 3/8-16 x 1 Gr5	84	532156085	Keeper Belt Idler
19	532132827	Bolt Shoulder 5/16-18 Thd Form	116	532137644	Bolt Shoulder
20	532165484	Bolt 3/8-24 x 1.25 Gr8 Ptch Lhthd	117	532133957	Wheel Gage Donut Wide
21	873680500	Nut Crown Lock 5/16-18	118	873930600	Nut Centerlock 3/8-16 Unc
22	532169165	Bracket Idler RR	119	819121414	Washer 3/8 x 7/8 x 14 Ga.
23	532169166	Bracket Idler RF	124	872110612	Bolt Carr Sh 3/8-16 x 1-1/2 Gr5
24	532169170	Bracket Suspension LF	128	532153390	Washer Felt
25	532169171	Bracket Suspension RF	130	872110506	Bolt Rdhdsqnk 5/16-18 Unc x 3/4
26	532165237	Brace Support Susp Frt CRD	131	532165661	Chute Bagger CRD 92cm
27	532169172	Bracket Asm. Susp RR	-	532130794	Mandrel Asm Service
28	532169168	Bracket Asm. Susp LR	-	532165579	Mandrel Asm CRD Lh Threads SVC
30	532157722	Screw Thd Rolling Washer Head	-	532170273	Deck Mower Complete
31	532129963	Washer Spacer Mower Vented			
32	532153535	Mandrel Pulleys			

NOTE: All component dimensions given in U.S. inches
1 inch = 25.4 mm

www.emc-motors.com

REPAIR PARTS

TRACTOR- -MODEL NO. ICT16A (JICTH16E) PRODUCT NO. 954 13 00-42
BAGGER

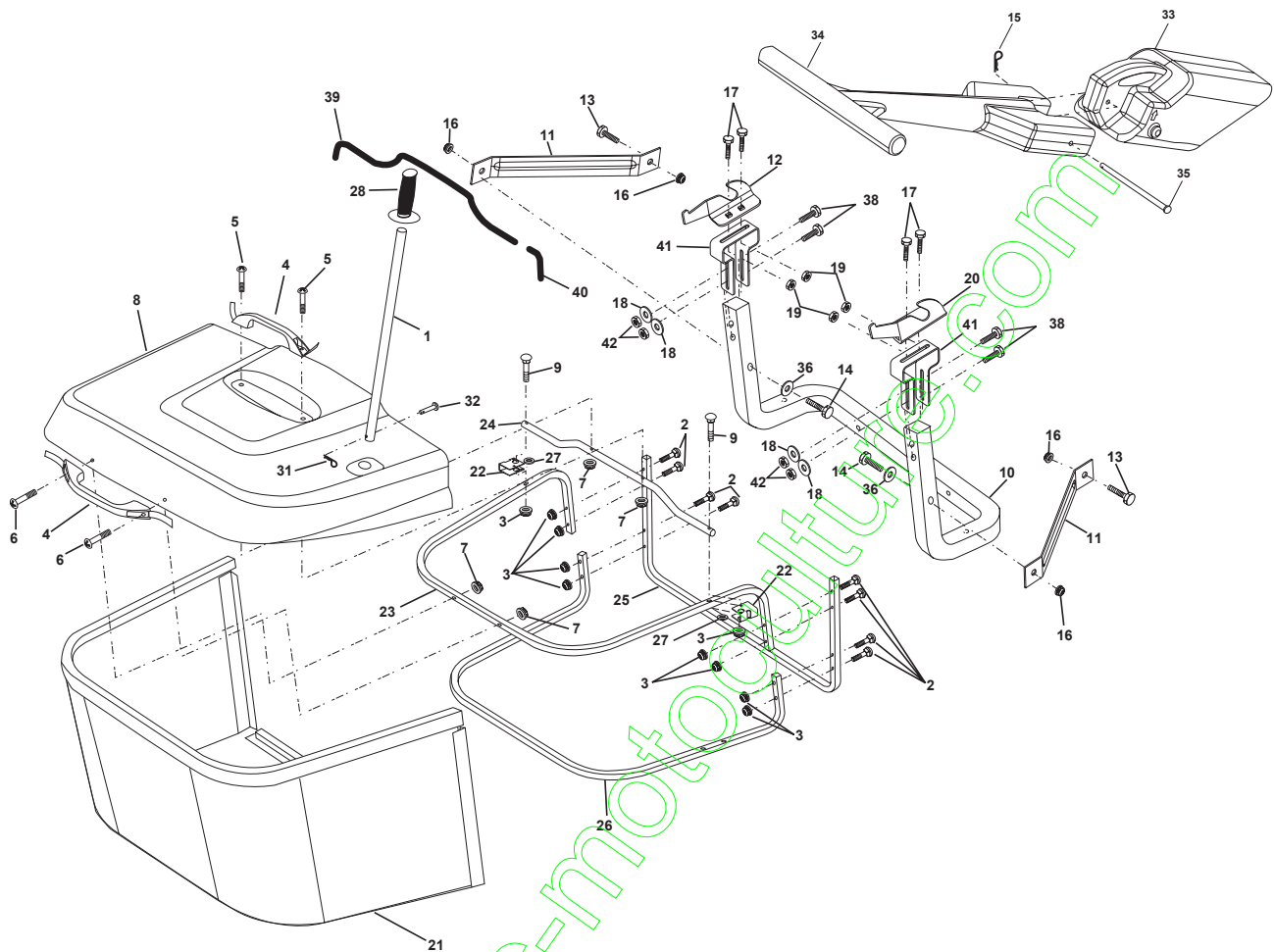

KEY NO.	PART NO.	DESCRIPTION	KEY NO.	PART NO.	DESCRIPTION
1	532170690	Tube Handle Bagger CRD	21	532165780	Bag Asm CRD
2	872140416	Bolt Carriage 1/4-20 X 2.0 Gr.5	22	532165781	Bracket Side Bagger CRD
3	532123976	Nut Lock 1/4 Lge Flg Gr. 5 Zinc	23	532165782	Tube Upper Bagger CRD
4	532169916	Handle Bagger w/Lyrs Gr. 5 Zinc	24	532165783	Tube Pivot Bagger CRD
5	874981024	Screw Pan Head #10-24 X 1.50 Blk	25	532165784	Tube Front Bagger CRD
6	874981032	Screw Pan Hd	26	532165785	Tube Lower Bagger CRD
7	873401000	Nut Wiz Lock Hex Serr/Hd #10-24	27	532169692	Bushing Snap Bagger CRD
8	532168871	Cover Bagger Plastic CRD	28	532170696	Grip Handle Black
9	872140418	Bolt Carriage 1/4-20 x 2.25d x Gr.5	31	532124788	Retainer Spring 1" Zinc/Cad
10	532169688	Tube Support Bagger CRD	32	532126875	Rivet Rd Hd Drilled 3/8 Dia
11	532165719	Bracket Support Upper Bag CRD	33	532169380	Plug Mulch 107 CRD
12	532169685	Bracket Horiz. Adj Bagger	34	532165570	Handle Mulcher 92/107 CRD
13	872110606	Bolt Rdhd Sht Sqnk 3/8-16 X 3/4	35	532165572	Pin Mulcher 92/107 CRD
14	874520640	Bolt Hex 3/8-16 X 2-1/2 Gr. 5	36	819132016	Washer 13/32 x 1-1/4 x 16 Ga.
15	532124670	Retainer Spring	38	872010520	Bolt 5/16-18 x 2-1/2
16	873900600	Nut Lock Flg 3/8-16 Unc	39	532169999	Seal 26" (Long)
17	872140506	Bolt Rdhd Sht Sqnk 5/16-18Unc X 3/4	40	532170000	Seal 7" (Short)
18	819111216	Washer 11/32 x 3/4 x 16 Ga.	41	532169683	Bracket Vert Adj Bagger CRD
19	873900500	Nut Lock Hex Flange 5/16-18 Unc Pl	42	873800500	Nut Lock Hx W/Ins 5/16-18 Unc
20	532169684	Bracket Horiz Adj Bagger			

NOTE: All component dimensions given in U.S. inches
1 inch = 25.4 mm

TRACTOR- -MODEL NO. ICT16A (JICTH16E) PRODUCT NO. 954 13 00-42 SCHEMATIC

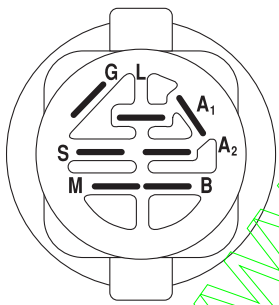
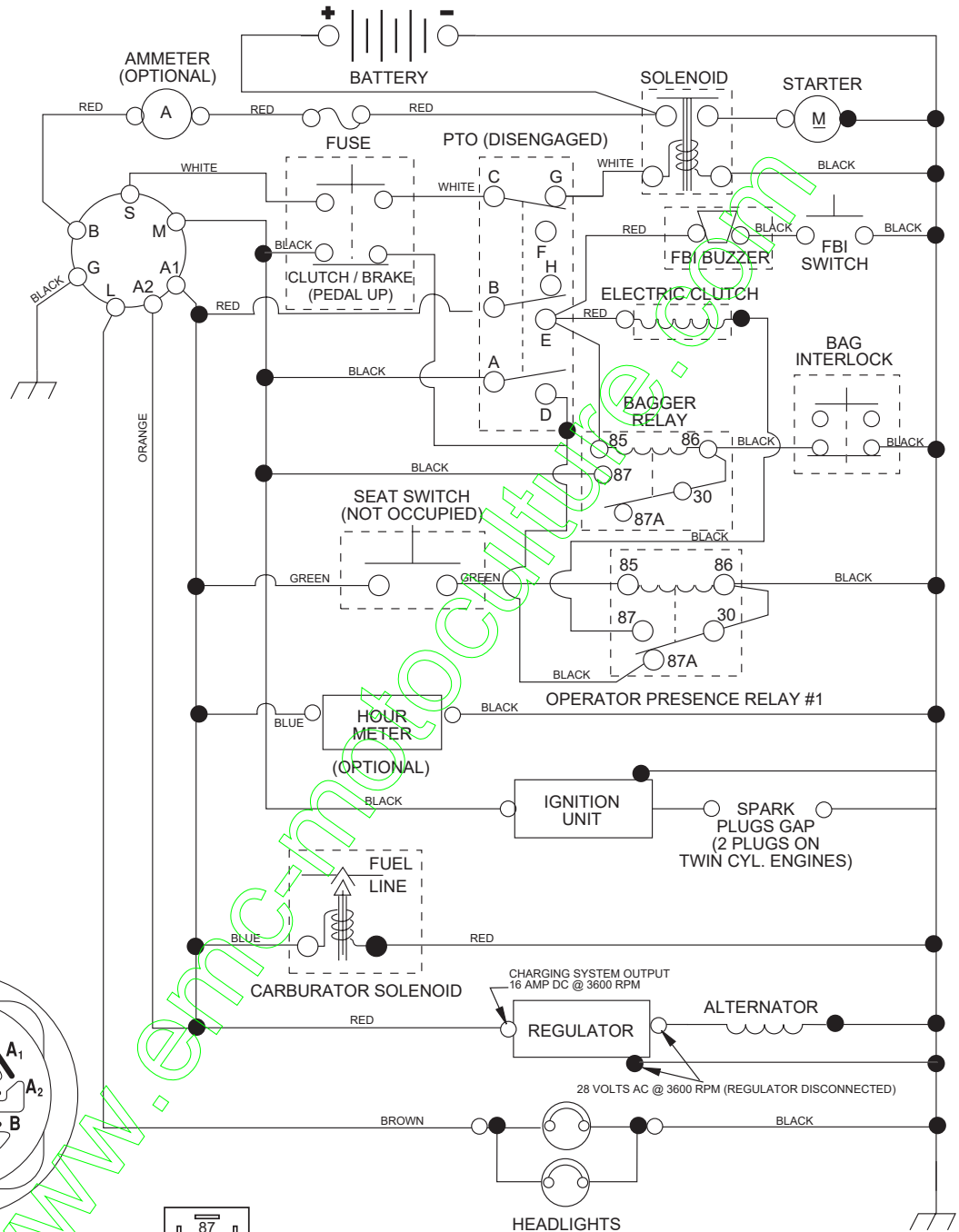

IGNITION SWITCH

POSITION	CIRCUIT	"MAKE"
OFF	M+G+A1	NONE
RUN/LIGHT	B+A1	A2+L
RUN	B+A1	NONE
START	B + S + A1	NONE

WIRING INSULATED CLIPS
NOTE: IF WIRING INSULATED CLIPS WERE REMOVED FOR SERVICING OF UNIT, THEY SHOULD BE REPLACED TO PROPERLY SECURE YOUR WIRING.

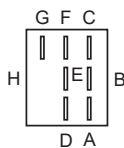
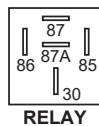

POSITION	CIRCUIT
OFF	C + G, B + H
ON	C + F, B + E, A + D

●
NON-REMOVABLE CONNECTIONS

○
REMOVABLE CONNECTIONS