

# ICT18A

Spare parts  
Ersatzteile  
Pièces détachées  
Reserve onderdelen  
Repuestos  
Reservdelar

[www.emc-motoculture.com](http://www.emc-motoculture.com)

# REPAIR PARTS

TRACTOR- -MODEL NO. ICT18A (JICTH18C), PRODUCT NO. 954 13 00-43  
ELECTRICAL

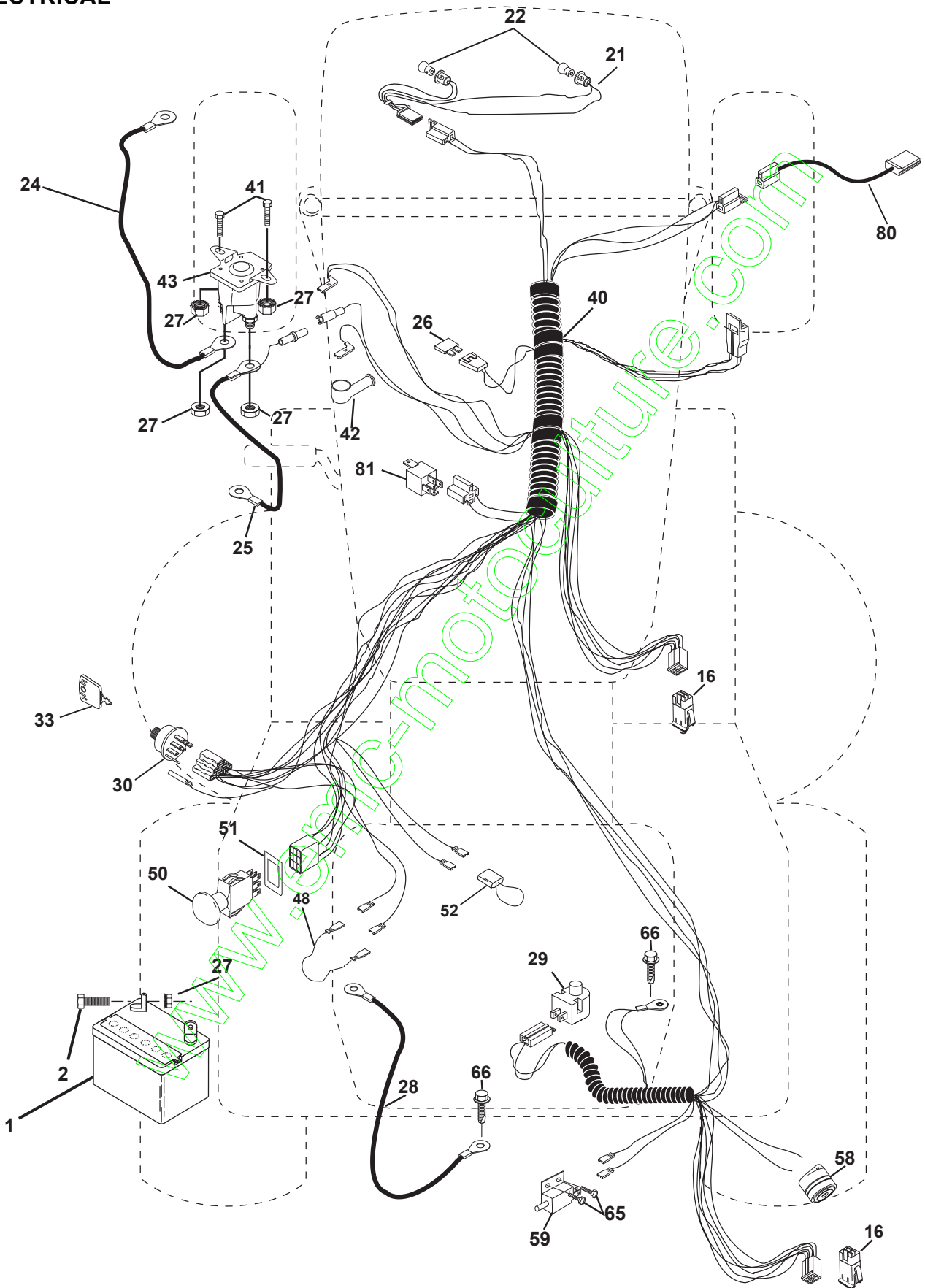

# REPAIR PARTS

TRACTOR- -MODEL NO. ICT18A (JICTH18C), PRODUCT NO. 954 13 00-43  
ELECTRICAL

KEY NO.	PART NO.	DESCRIPTION
1	532144927	Battery
2	874760412	Bolt Hex Hd 1/4-20 Unc X 3/4
16	532153664	Switch Interlock Push-In
21	532166182	Harness Asm Light W/4152J
22	532004152	Bulb Light #1156
24	532124780	Cable Starter 6Ga 11" Red
25	532165987	Cable Battery Crd 56" Red
26	532175158	Fuse 20 Amp
27	873510400	Nut Keps Hex 1/4-20 Unc
28	532127725	Cable Ground 6Ga 18" Black
29	532160784	Switch Plunger Normal Op Olive
30	532175566	Switch Ignition
33	532140401	Key Ign
40	532170214	Harness Ign Crd Elect
41	871110408	Bolt Flk Fin Hex 1/4-20 Unc X 1/2
42	532131563	Cover Terminal Red
43	532175141	Solenoid
48	532140844	Adapter Ammeter Rectangular
50	532174652	Switch PTO
51	532140405	Ring Retainer PTO
52	532141940	Protection Wire Loop
58	532169419	Buzzer Crd
59	532166299	Switch FBI CRD
65	817211008	Screw Slftp #10-16 x 1/2 Ty-Ab
66	817490608	Screw Thdrol 3/8-16 x 1/2 Ty-Tt
80	532146685	Harness Clutch EVX
81	532109748	Relay Asm

**NOTE:** All component dimensions given in U.S. inches.  
1 inch = 25.4 mm.

# REPAIR PARTS

TRACTOR- -MODEL NO. ICT18A (JICTH18C), PRODUCT NO. 954 13 00-43  
CHASSIS AND ENCLOSURES

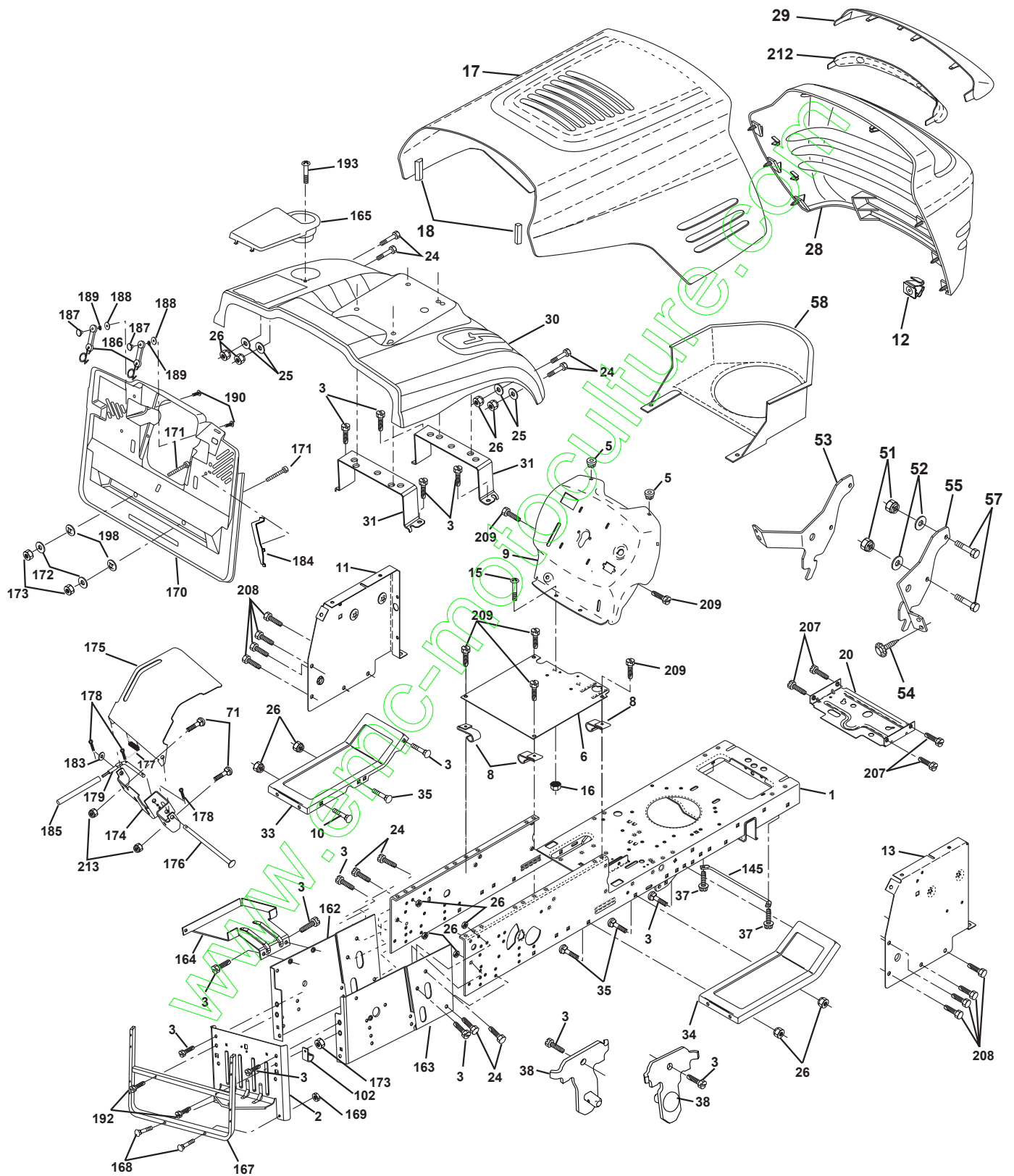

# REPAIR PARTS

TRACTOR- -MODEL NO. ICT18A (JICTH18C), PRODUCT NO. 954 13 00-43  
CHASSIS AND ENCLOSURES

KEY NO.	PART NO.	DESCRIPTION	KEY NO.	PART NO.	DESCRIPTION
1	532169831	Chassis	145	532156524	Rod Pivot Chassis/Hood
2	532165606	Drawbar	162	532170256	Bracket Exten Chassis Lh CRD
3	817060612	Screw 3/8-16 x .75	163	532175770	Bracket Exten Chassis Rh CRD
5	532155272	Bumper Hood/Dash	164	532165605	Support Battery CRD
6	532155923	Saddle	165	532168407	Cover Battery CRD Lt
8	532126471	Clip Insulator 13/32 Mtg. Hole	167	532165779	Support Asm. Backplate WLDMNT
9	532172099	Dash	168	872050412	Bolt, RDHD SHT NK 1/4-20 x 1-1/2
10	872140608	Bolt, Carriage 3/8-16 x 3/4	169	532123976	Nut, Lock 1/4 LGE FLG Gr. 5 Zinc
11	532155927	Panel, Dash, L.H.	170	532175264	Backplate Black
12	532145660	Clip Tinnerman Grille P/L	171	<b>872140620</b>	Bolt Carr. 3/8-16 x 2-1/2 Gr 5
13	532172108	Panel, Asm. Dash R.H.	172	819132016	Washer 13/32 x 1-1/4 x 16 Ga.
15	874180512	Screw, Machine, Truss Head 5/16-18 UNC x 3/4	173	873510600	Nut, Keps Hex 3/8-16 UNC
16	873510500	Nut	174	532165939	Bracket Switch FBI CRD
17	532150760	Hood Assembly	175	532166212	Guard Door Rear CRD
18	532126938	Bumper Hood	176	532128600	Pin Hinge Pivot
20	532156437	Plate Mtg. Battery/Fuel Tank	177	532132796	Spring Bagger Top LH Black
24	874780616	Bolt	178	876020312	Pin Cotter 3/32 x 3/4 Cad Zinc
25	819131312	Washer 13/32 x 13/16 x 12 Gauge	179	532165942	Rod Pivot FBI CRD
26	873800600	Nut	180	874760516	Bolt Hex HD 5/16-18 UNC x 1
28	532169509	Grille	181	873680500	Nut Crownlock 5/16-18
29	532166603	Lens, Grille	183	819131316	Washer 13/32 x 13/16 x 16 Ga.
30	532175843	Fender	184	532174662	Bracket Actuator Bagger CRD
31	532165156	Bracket, Fender Support	185	532165940	Tube Lever Switch FBI CRD
33	532149139	Footrest, L.H.	186	532160793	Latch Asm Multch Bagger
34	532149140	Footrest, R.H.	187	532125004	Nut Weld .327/.304 #10-24
35	872110606	Bolt	188	819061216	Washer #10
37	817490508	Screw Thdrol 5/16-18 x 1/2 TYT	189	810071000	Washer Lock #10
38	532169834	Bracket Asm Pivot Mower Rear	190	871081010	Screw Pan Hd Phil 10-24 x 5/8
51	873800400	Nut Lock w/Insert 1/4-20 UNC	192	817060624	Screw 3/8-16 x 1-1/2
52	819091416	Washer 9/32 x 7/8 x 16 Ga.	193	817070412	Screw Truss 1/4-20 x 3/4
53	532145201	Bracket Grille Pick off Lh	198	532168937	Nut, Push
54	532161464	Screw Hex Ws Hd 8-18 x 7/8	207	817670508	Screw Thdrol 5/16-18 x 1/2
55	532145202	Bracket Grille Pick off Rh	208	817670608	Screw Thdrol 3/8-16 x 1/2
57	874780412	Bolt, Fin Hex 1/4-20 UNC x .75	209	817000612	Screw Hexwsh Thdr 3/8-16 x 3/4
58	532174930	Duct Intake Air	212	532165919	Insert Lens Reflective
71	<b>872110406</b>	Bolt Carr.	213	<b>873680400</b>	Nut Crownlock 1/4-20
102	532124996	Clip Fuel Line 13/32 Mtg Hole			

**NOTE:** All component dimensions given in U.S. inches.  
1 inch = 25.4 mm.

# REPAIR PARTS

TRACTOR- -MODEL NO. ICT18A (JICTH18C), PRODUCT NO. 954 13 00-43  
DRIVE

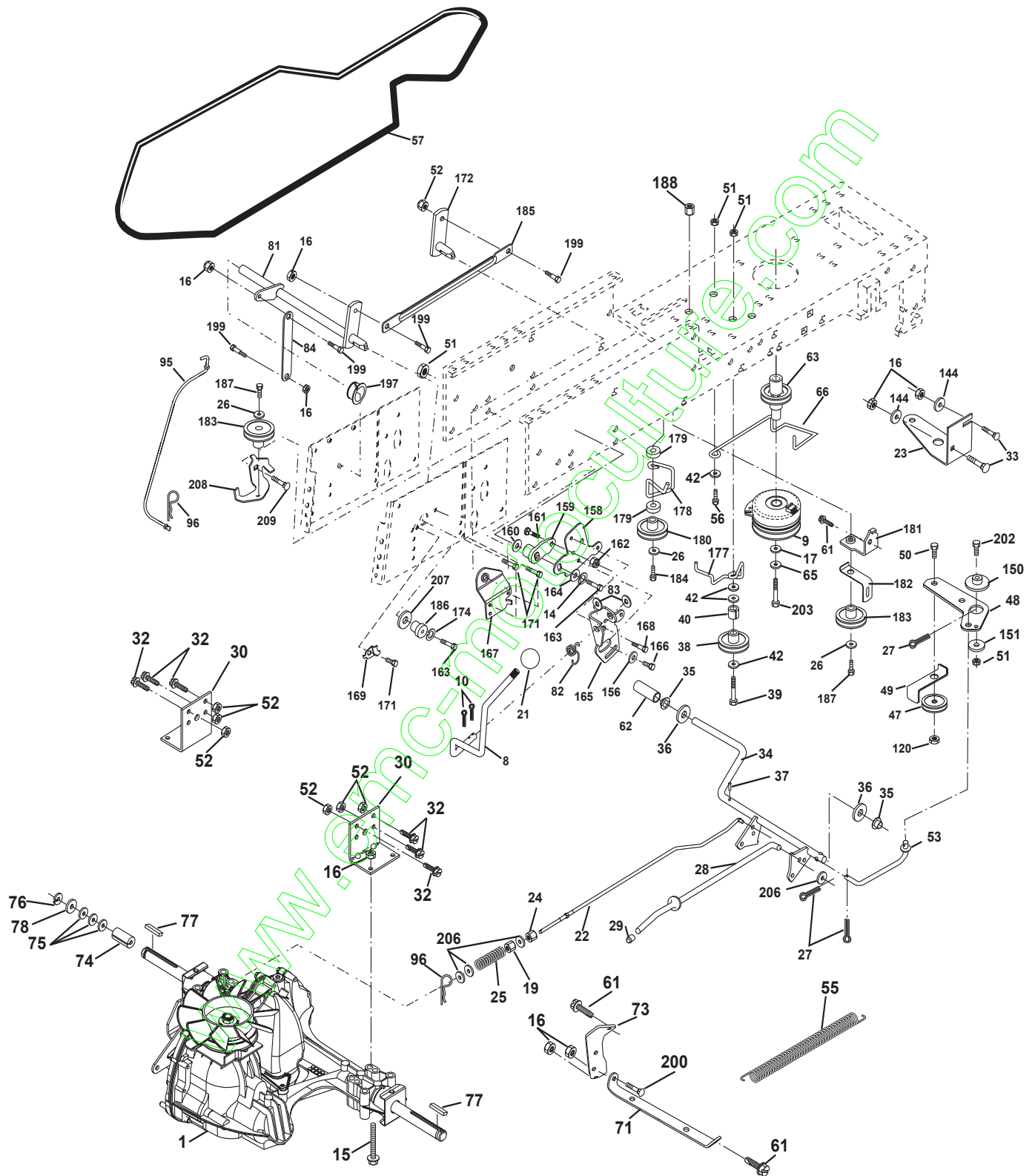



# REPAIR PARTS

TRACTOR- -MODEL NO. ICT18A (JICTH18C), PRODUCT NO. 954 13 00-43  
DRIVE

KEY NO.	PART NO.	DESCRIPTION	KEY NO.	PART NO.	DESCRIPTION
1	-----	Transaxle Hydro Gear 321-0510 (Order parts from transaxle manufacturer)	78	532121748	Washer 25/32 x 1-5/8 x 16 Ga.
8	532165619	Rod, Shift Fender Adjust Lt	81	532170006	Asm, Shaft
9	532175540	Clutch Ele EVX	82	532123782	Spring, Torsion
10	876020416	Pin, Cotter 1/8 x 1	83	819171216	Washer 17/32 x 3/4 x 16 Ga.
14	810040400	Washer, Lock Hvy Helical	84	532170007	Link, Transaxle
15	874490544	Bolt Hex FLGHD 5/16-18 Gr. 5	95	532170015	Control Asm Bypass Hydro
16	873800500	Nut, Lock Hex w/Ins 5/16-18 UNC	96	532124788	Spring, Retainer 1"
20	871170780	BOlt Hex 7/16-20 x 5	120	873900600	Nut Lock Flg 3/8-16 UNC
21	532130564	Knob 1/4-13 Unc Blk	144	819111016	Washer 11/32 x 5/8 x 16 Ga.
22	532170137	Rod, Brake	150	532165850	Bushing, Bellcrank Grnd Dr
23	532170017	Bracket asm Clutch Mtg.	151	819133210	Washer 13/32 x 2 x 10 Ga.
24	873350600	Nut	153	874760516	Bolt Hex Hrd 5/16-18 Unc x 1
25	532106888	Spring, Rod, Brake	156	532166002	Washer Strted 5/16ID x 1.125
26	819131316	Washer 13/32 x 13/16 x 16 Ga.	158	532165589	Bracket Shift Mount
27	876020412	Pin, Cotter 1/8 x 3/4	159	532165494	Hub Tapered Flange Shift Lt
28	532145204	Rod, Parking Brake	160	819292016	Washer 29/32 x 1-1/4 x 16 Ga.
29	532071673	Cap, Parking Brake	161	872140406	Bolt Rdhd Sqnk 1/4-20 x 3/4 Gr 5
30	532169592	Bracket, Mfg. Transaxle	162	873680400	Nut Crownlock 1/4-20 Unc
32	874760512	Bolt Hex 5/16-18 UNC x 3/4	163	874780416	Bolt Hex Fin 1/4-20 Unc x 1 Gr 5
33	872140506	Bolt Rdhd Sqnk 5/16-18 Unc x 3/4	164	819091010	Washer 5/8 x .281 x 10 Ga.
34	532165496	Shaft, Asm Pedal Foot CRD	165	532165623	Bracket Pivot Lever
35	532120183	Bearing, Nylon	166	532166880	Screw 5/16-18 x 5/8
36	819211616	Washer 21/32 x 1 x 16 Ga.	167	532165588	Bracket Support Shift CRD
37	532124963	Pin, Roll 3/16 x 1"	168	532165492	Bolt Shoulder 5/16-18 x .561
38	532165936	Pulley Flat Composite 3.06"	169	532165580	Plate Fastening Lt
39	874760644	Bolt Fin Hex 3/8-16 Unc x 2-3/4	171	817490608	Screw Thdrol 3/8-16 x 1/2 Ty-Tt
40	532124965	Spacer, Split 395 x 59 Bzp	172	532170271	Shaft Asm Shifter Frt
42	819131312	Washer 13/32 x 13/16 x 12 Ga.	174	810090400	Washer Lock 1/4
47	532127783	Pulley, Idler, V Groove Plasic	177	532165932	Keeper Flat Idler 3.06" CRD
48	532154407	Bellcrank Clutch Grnd Drv	178	532165933	Keeper Belt Idler 1.88" CRD
49	532123205	Retainer, Belt Style Spring	179	532120958	Washer Sintered
50	874760624	Bolt Hex Hd 3/8-16 UNC x 1-1/2	180	532165630	Pulley, Idler, Flat 1.88" CRD
51	873680600	Nut, Crownlock 3/8-16 UNC	181	532165797	Bracket Idler Ground Drive CRD
52	873680500	Nut Crownlock 5/16-18	182	532165634	Keeper Belt 2.5" Od V-Idler CRD
53	532105710	Link, Clutch 7.66	183	532165626	Pulley V-Idler 2.50" Od CRD
55	532105709	Spring, Return, Clutch	184	817490644	Screw Hexwsh Thdrol 3/8-16 x 2-3/4
56	874760620	Bolt, Hex 3/8-16 UNC x 1-1/4	185	532170008	Link Shift CRD Hydro
57	532170140	V-Belt Kev 113"	186	532165614	Hub Tapered Round CRD
61	817060612	Screw 3/8-16 x 3/4	187	817060620	Screw 3/8-16 x 1-1/4
62	532008883	Cover, Pedal	188	532110436	Bushing Snap Split Blk
63	532145868	Pulley, Clutch elect EVX 1"	197	532169613	Nyliner Snap-In 5/8" ID
65	810040700	Washer	199	532169612	Bolt Shoulder 5/16-18 UNC
66	532154778	Keeper, Belt Engine F-Proof	200	872140508	Bolt RDHD SQNK 5/16-18unc x 1
71	532169183	Strap, Torque, Lh	202	872110612	Bolt Carr. Sh. 3/8-16 x 1-1/2 Gr. 5
73	532169182	Strap, Torque, Rh	206	819131416	Washer 13/32 x 7/8 x 16 Ga.
74	532137057	Spacer	207	532169845	Washer Nylon Rear
75	532121749	Washer 25/32 x 1-1/4 x 16 Ga.	208	532169844	Bracket Idler Rear LH
76	812000001	Ring, E	209	872110606	Bolt RDHD SQNK 3/8-16 x 3/4
77	532123583	Key, Square			

**NOTE:** All component dimensions given in U.S. inches  
1 inch = 25.4 mm

# REPAIR PARTS

TRACTOR- -MODEL NO. ICT18A (JICTH18C), PRODUCT NO. 954 13 00-43  
STEERING ASSEMBLY

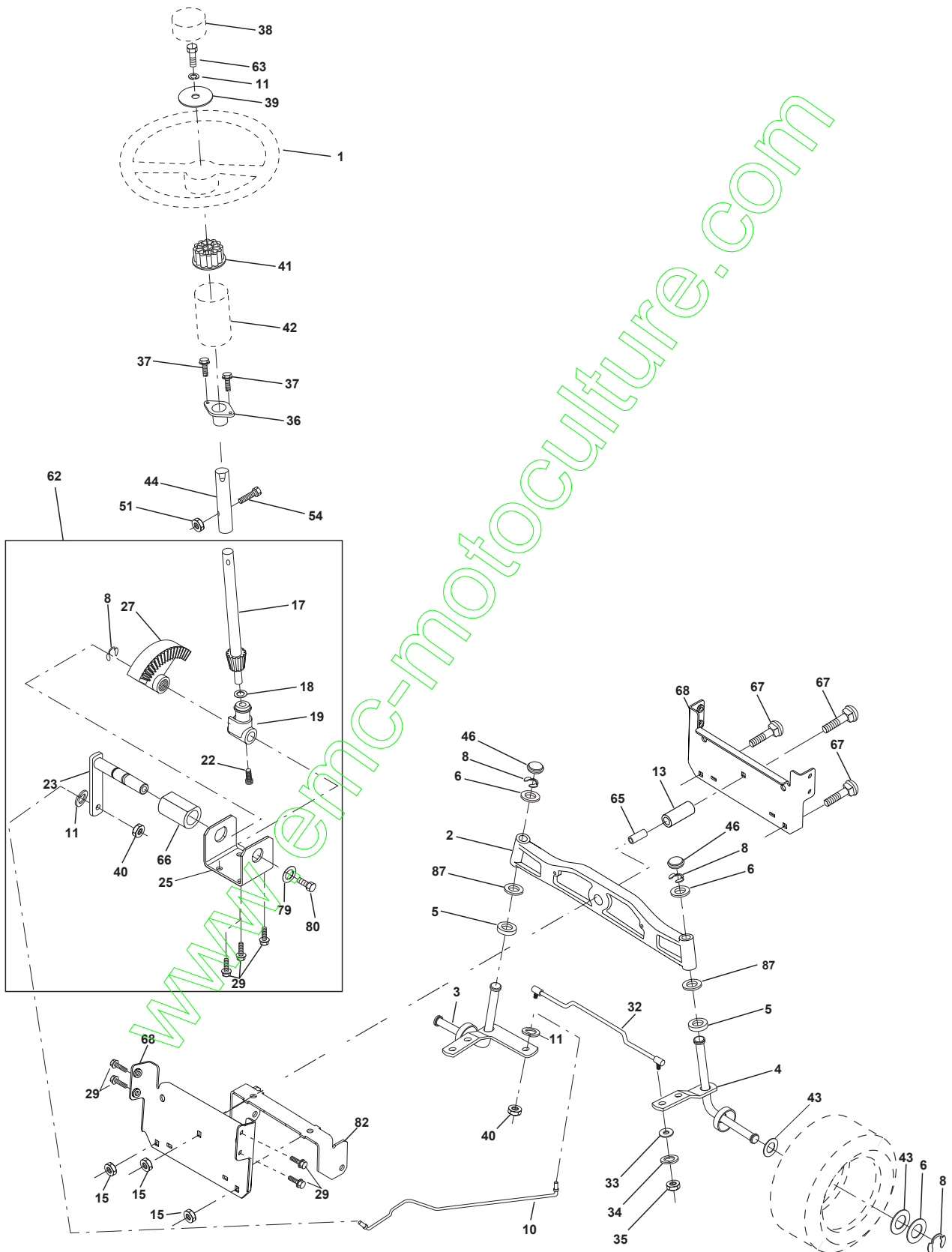



# REPAIR PARTS

TRACTOR- -MODEL NO. ICT18A (JICTH18C), PRODUCT NO. 954 13 00-43  
STEERING ASSEMBLY

KEY NO.	PART NO.	DESCRIPTION
1	532172092	Steering Wheel
2	532172393	Axle Cast Lt Iron
3	532169840	Spindle Assembly, L.H.
4	532169839	Spindle Assembly, R.H.
5	532124931	Bearing, Race, Thrust, Hardened
6	532121748	Washer 25/32 x 1-5/8 x 16 Gauge
8	812000029	Ring, Klip
10	532169832	Link, Drag
11	810040600	Washer, Lock
13	532136518	Spacer Brg Axle Front
15	532145212	Nut, Hexflange Lock
17	532156546	Shaft Assembly, Steering
18	532057079	Washer, Thrust .515 x .750 x .033
19	532160395	Support, Shaft
22	532165857	Screw Hex Wshhd Torx
23	532165851	Pittman Shaft Assembly
25	532154406	Bracket, Steering
27	532136874	Gear, Sector
29	817060612	Screw 3/8-16 x 3/4
32	532170162	Rod, Tie
33	819111216	Washer 11/32 x 3/4 x 16 Ga
34	810040500	Washer Lock Hvy Hlcl Spr 5/16
35	873540500	Crownlock 5/16-24 Unf
36	532155099	Bushing, Steering
37	532152927	Screw TT #10-32 x 5 x 3/8 Flange
38	532172093	Cap Wheel Steering
39	819132411	Washer 13/32 x 1-1/20 x 11 Gauge
40	532124701	Nut Lock Center 3/8-24 Unf
41	532159945	Adaptor, Steering Wheel
42	532169633	Boot, Steering
43	532121749	Washer 25/32 x 1-1/4 x 16 Gauge
44	532153720	Extension Steering Non-Adjust
46	532121232	Cap, Spindle
51	873800500	Nut Lock Hx W/Ins 5/16-18 UNC
54	874780520	Bolt Fin Hex 5/16-18 UNC x 1-1/4
62	532167902	Kit, Steering Assembly, Service
63	874780616	Bolt Fin Hex 3/8-16 unc. x 1 Gr. 5
65	532160367	Spacer Brace Axle
66	532154404	Bearing Arm Pittman
67	872140618	Bolt Rdhd Sq 3/8-16unc x 2-1/4
68	532169827	Brace Axle
79	819132012	Washer 13/32 x 1-1/4 x 12 Ga
80	874950612	Bolt Hex Nylon 3/8-16 x 3/4
82	532169835	Bracket Susp Chassis Front
87	532173966	Washer Flat .781 x 1-1/2 x .14

**NOTE:** All component dimensions given in U.S. inches.  
1 inch = 25.4 mm.

# REPAIR PARTS

TRACTOR- -MODEL NO. ICT18A (JICTH18C), PRODUCT NO. 954 13 00-43  
SEAT ASSEMBLY

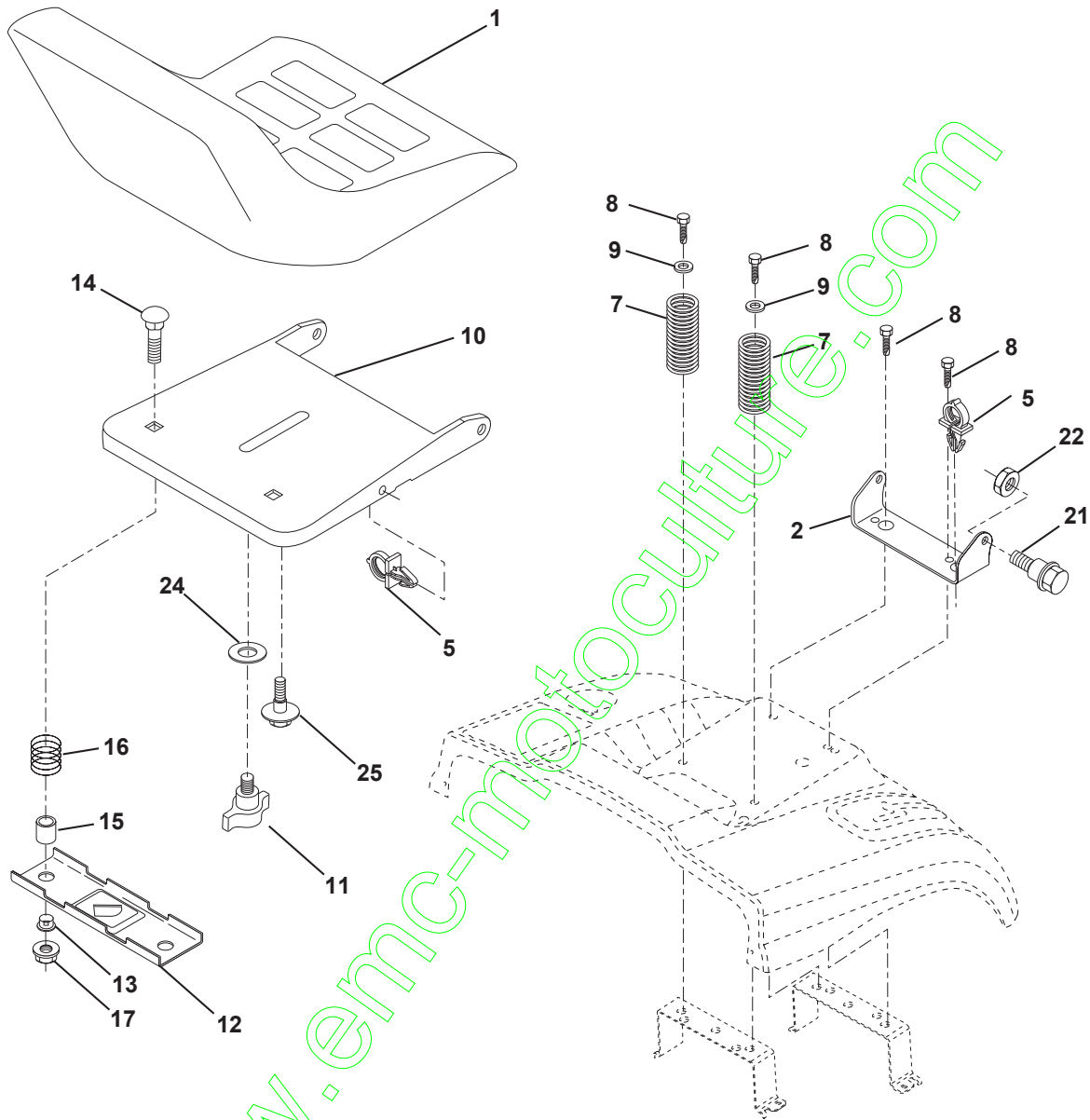

KEY NO.	PART NO.	DESCRIPTION
1	532140118	Seat
2	532140551	Bracket Pnt Pivot Seat (blk )
5	532145006	Clip Push In Hinged
7	532124181	Spring Seat Cprsn 2 250 Blk Zi
8	817000616	Screw 3/8-16 X 1-1/2
9	819131614	Washer 13/32 X 1 X 14 Ga
10	532174894	Pan Pnt Seat (blk )
11	532166369	Knob Seat Adj. Wingnut
12	532121246	Bracket Pnt Mounting Switch

KEY NO.	PART NO.	DESCRIPTION
13	532121248	Bushing Snap Blk Nyl 50 Id
14	872050412	Bolt Rdhd Sht Nk 1/4-20x1-1/2
15	532121249	Spacer Split 28 X 88 Zinc
16	532123740	Spring Cprsn
17	532123976	Nut Lock 1/4 Lge Flg Gr 5 Zinc
21	532171852	Bolt Shoulder 5/16-18 Unc-2A
22	873800500	Nut Hex Lock w/Ins 5/16-18
24	819171912	Washer 17/32 X 1-3/16 X 12 Ga.
25	532127018	Bolt Shoulder 5/16-18 X 62

**NOTE:** All component dimensions given in U.S. inches.  
1 inch = 25.4 mm

# REPAIR PARTS

TRACTOR- -MODEL NO. ICT18A (JICTH18C), PRODUCT NO. 954 13 00-43  
DECALS

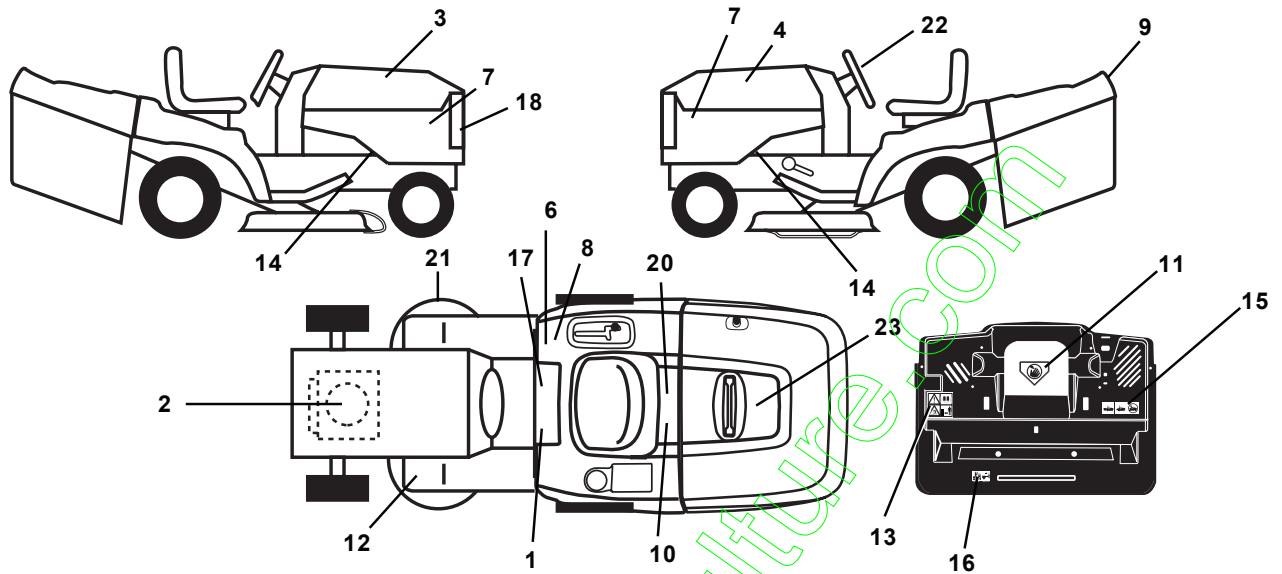

KEY NO.	PART NO.	DESCRIPTION
1	532145498	Decal Read Owner's Manual Sym
2	532170850	Decal Hp Engine
3	532170535	Decal Hood Rh
4	532170536	Decal Hood Lh
6	532126187	Decal 100 DBA
7	532162927	Decal Hood Insert
8	532145437	Decal Europe Stand Ce
9	532141761	Decal Fender Logo
10	532145005	Decal Bat Dan/Poi P/L Sym Wpn
11	532145494	Decal Mower Cut Finger Symbol
12	532159737	Decal Brake/Clutch Symbol Lt
13	532166959	Decal Warn Back Plate CRD
14	532159736	Decal Chassis Hot Muffler

KEY NO.	PART NO.	DESCRIPTION
15	532166961	Decal Oper Bag Presence CRD
16	532162598	Decal Drawbar Load Limit
17	532140837	Decal Saddle Brake Parking
18	532152262	Decal Grille
20	532166960	Decal Bypass Fender CRD
21	532166286	Decal Hex Belt Sch CRD
22	532170565	Decal Ins Strg Whl
23	532170654	Decal Bagger Top CRD
—	532138311	Decal Lift Handle
—	532171237	Pad Footrest
—	532175753	Manual Operator's (Euro)
—	532175754	Manual Operator's (Scan)

## WHEELS & TIRES

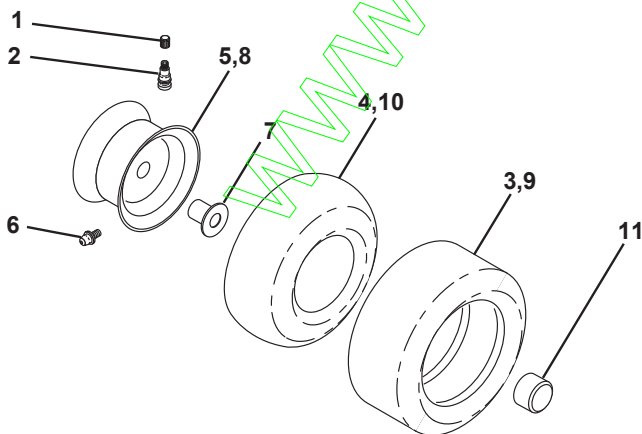

KEY NO.	PART NO.	DESCRIPTION
1	532059192	Cap Value Tire
2	532065139	Stem Value
3	532106222	Tire F Ts 15 X 6 0 - 6 Service
4	532059904	Tube Inner Front #35060
5	532138336	Rim Asm 6"front Silver Service
6	532124957	Fitting Grease
7	532124959	Bearing Flange
8	532138337	Rim Asm 8"rear Silver Service
9	532138468	Tire R Ts 20 x 8-8 Service
10	532124926	Tube Rear 9 5 X 8 Service
11	532175039	Cap Axle Blk 1 50 X 1 00
--	532144334	Sealant, Tire (10 oz. tube)

**NOTE:** All component dimensions given in U.S. inches  
1 inch = 25.4 mm

# REPAIR PARTS

TRACTOR- -MODEL NO. ICT18A (JICTH18C), PRODUCT NO. 954 13 00-43  
ENGINE

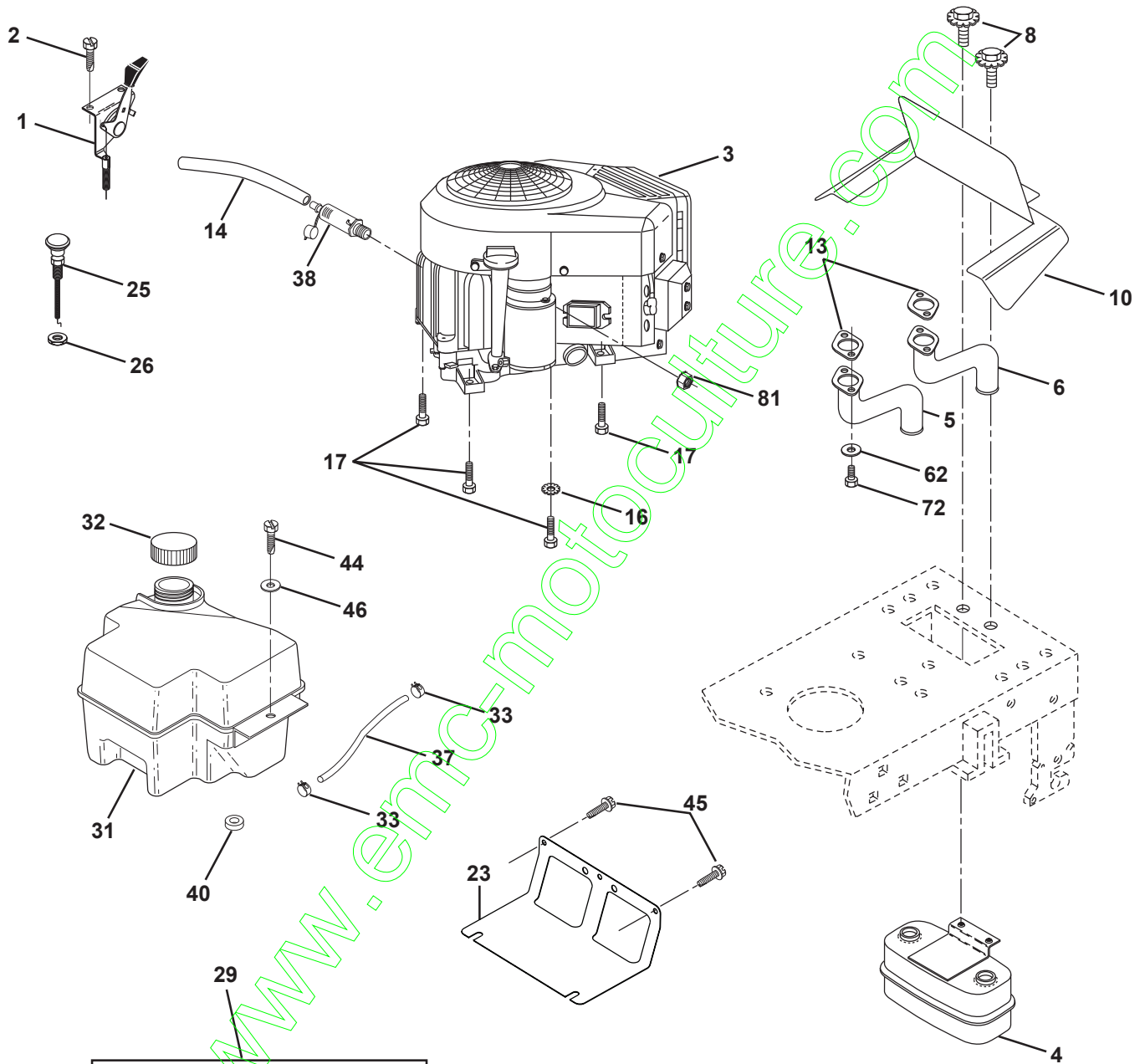

**OPTIONAL EQUIPMENT**  
**Spark Arrester**

# REPAIR PARTS

TRACTOR- -MODEL NO. ICT18A (JICTH18C), PRODUCT NO. 954 13 00-43  
ENGINE

KEY NO.	PART NO.	DESCRIPTION
1	532170771	Control Throt
2	817720410	Screw Hex Thd Cut 1/4-20x5/8 T
3	-----	Engine B&S Model 407777 (Order parts from engine manufacturer)
4	532149723	Muffler Twin Lo-Twin
5	532159955	Tube, Manifold Lh
6	532160589	Tube, Manifold Rh
8	532171877	Bolt 5/16-18 Unc x 3/4 w/Sems
10	532162797	Shield Browning Intek
13	532165391	Gasket Muffler
14	532148456	Tube Drain Oil Easy
16	811050600	Washer Lock Ext Tooth 3/8
17	817490624	Screw, Thdrol 3/8-16 x 1-1/2 Tytt
23	532169837	Shield Brn/Dbr Guard
25	532145996	Choke Control 37"
26	873920600	Nut, Keps 3/8-24 Unf
29	532137180	Kit Spark Arrestor (Flat Scrn)
31	<b>532174642</b>	Tank Fuel 2.00
32	532140527	Cap Asm Fuel W/sym Vented
33	532123487	Clamp Hose Blk
37	532137040	Line Fuel
38	532148315	Plug Drain Oil Easy
40	532124028	Bushing Snap
44	817670412	Screw Hexwsh Thdrol 1/4-20 x 3/4
45	817000612	Screw Hexwsh Thdrol 3/8-16 x 3/4
46	819091416	Washer 9/32 x 7/8 x 16 Ga.
62	810040500	Washer, Lock Hvy. Hlcl Spr 5/16
72	871070512	Screw Hex Hd Cap 5/16-18 x 3/4
81	873510400	Nut Keps Hex 1/4-20 Unc

**NOTE:** All component dimensions given in U.S. inches  
1 inch = 25.4 mm

# REPAIR PARTS

TRACTOR- -MODEL NO. ICT18A (JICTH18C), PRODUCT NO. 954 13 00-43  
MOWER LIFT

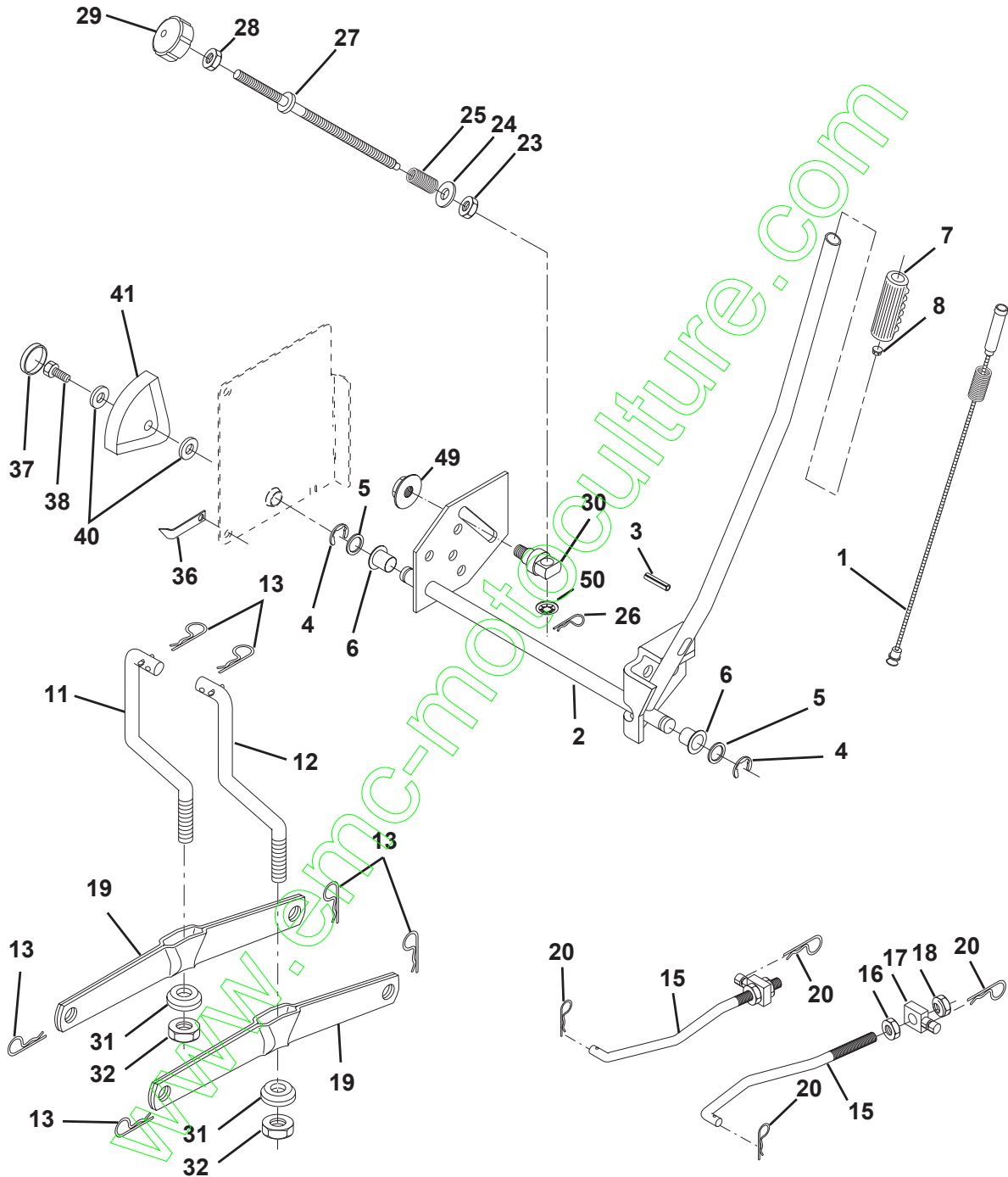



# REPAIR PARTS

TRACTOR- -MODEL NO. ICT18A (JICTH18C), PRODUCT NO. 954 13 00-43  
MOWER LIFT

KEY NO.	PART NO.	DESCRIPTION
1	532159460	Washer Asm Inner Spring W/Plunger
2	532159471	Shaft Asm. Lift
3	532105767	Pin Groove
4	812000002	E Ring #5133-62
5	819211621	Washer 21/32 x 1 x 21 Ga.
6	532120183	Bearing Nylon
7	532125631	Grip Handle Fluted
8	532124526	Button Plunger Black
11	532165829	Link Asm Lift L.H.
12	532165831	Link Asm Lift R.H.
13	532124670	Retainer Spring
15	532173288	Link Front
16	873350800	Nut Jam Hex 1/2-13 Unc
17	532130171	Trunnion Blk Zinc
18	873800800	Nut Lock W/Wsh 1/2-13 Unc
19	532139868	Arm Suspension Mower
20	532163552	Retainer Spring
23	532110807	Nut Special
24	819131016	Washer 13/32 x 5/8 x 16 Ga.
25	532124874	Spring 2-1/8"
26	532169484	Retainer Clip
27	532126971	Rod Adj Lift Zinc 7.49 Wrk Lg
28	873350600	Nut Hex Jam 3/8-16 Unc
29	532138057	Knob Inf 3/8-16 Unc Blk w/sym
30	532150233	Trunnion Infin Height
31	532169865	Bearing, Pvt. Lift.
32	873540600	Nut Crownlock 3/8-24
36	532155097	Pointer Height Indicator
37	532123935	Plug Hole Blk 1.485/1.515 Dia
38	817060516	Screw 5/16-18 x 1
40	819112410	Washer 11/32 x 1-1/2 x 10 Ga.
41	532123934	Scale Ind Height Blk
49	532145212	Nut hex Flange Lock
50	532110452	Nut Push Phos & Oil

**NOTE:** All component dimensions given in U.S. inches  
1 inch = 25.4 mm

# REPAIR PARTS

TRACTOR- -MODEL NO. ICT18A (JICTH18C), PRODUCT NO. 954 13 00-43  
MOWER

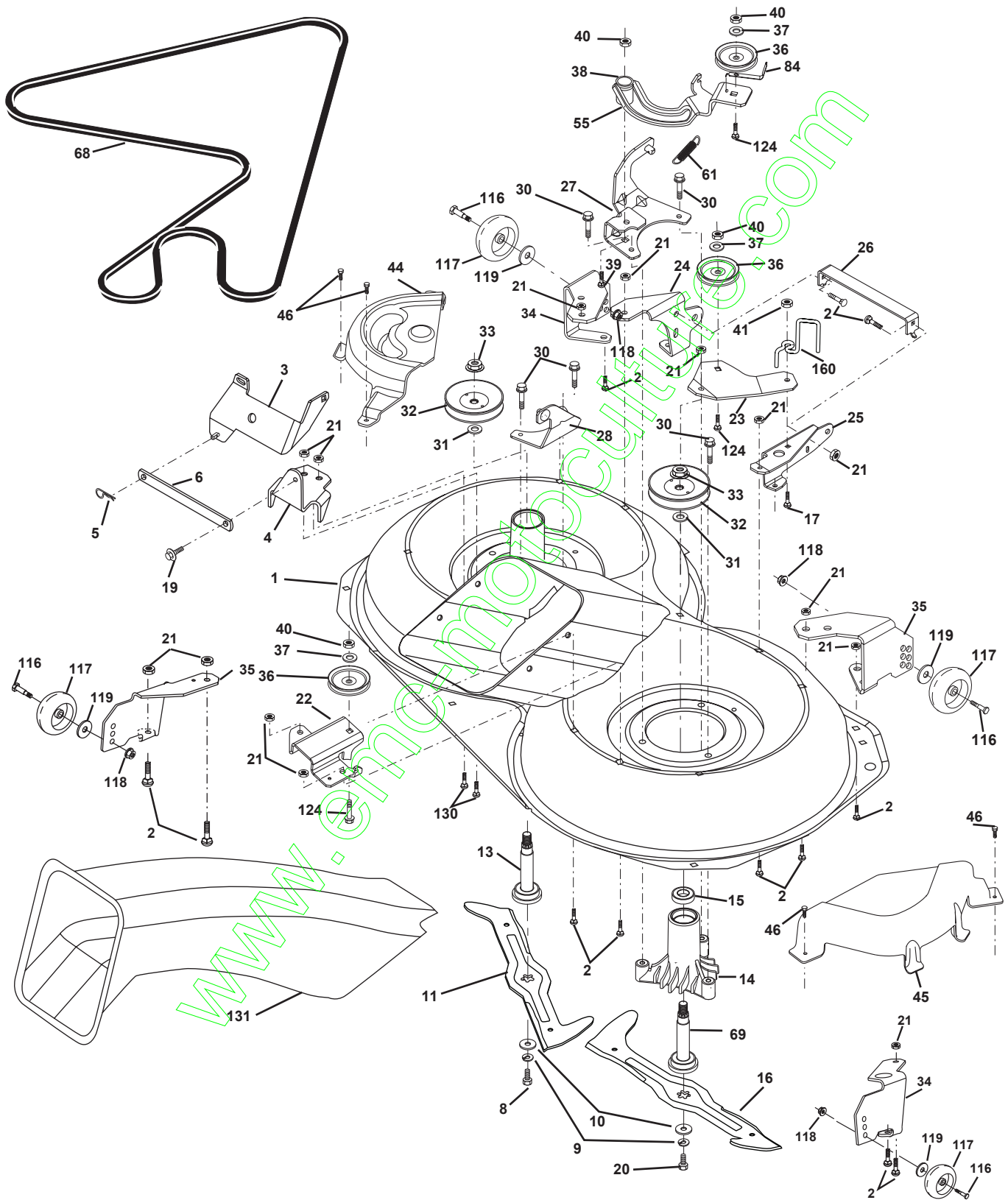

# REPAIR PARTS

TRACTOR- -MODEL NO. ICT18A (JICTH18C), PRODUCT NO. 954 13 00-43  
MOWER

KEY NO.	PART NO.	DESCRIPTION	KEY NO.	PART NO.	DESCRIPTION
1	532169160	Housing Asm. Mower 107 CRD	35	<b>532176292</b>	Bracket Gauge Wheel Rf 107 CRD
2	872140506	Bolt Rdhd Sqnk 5/16-18 Unc x 3/4	36	532146763	Pulley Idler V-Groove Dim 4.25
3	532165569	Bracket Asm. S-Bar Chass 92 CRD	37	819131316	Washer 11/32 x 13/16 x 16 Ga
4	532169167	Bracket Bar Sway Deck 107 CRD	38	532169851	Spacer Hub Arm Idler 107 CRD
5	532124670	Retainer Spring	39	872110622	Bolt Rdhd 3/8-16 Unc x 2-3/4 Gr. 5
6	532165557	Bar Sway 92 CRD	40	873680600	Nut Crownlock 3/8-16 Unc
8	532850857	Bolt 3/8-24 x 1.25 Gr8 Patched	41	873900600	Nut Lock FLG 3/8-16 UNC
9	810030600	Washer Lock Hvy 3/8 Unplated	44	532169180	Cover Mandrel Lh 107 CRD
10	532140296	Washer Hard Blade Mower vented	45	532169179	Cover Mandrel Rh 107 CRD
11	532175450	Blade 3-1 Lh 107 CRD	46	532137729	Screw Thd Roll 1/4-20 x 5/8
13	532137645	Shaft Asm. W/Lower Bearing	55	532169849	Arm Idler 107 CRD
14	532128774	Housing Mandrel Vented (Machd)	61	532175159	Spring Tension Belt
15	532110485	Bearing Ball Mandrel	68	532169178	Hex-Belt 107 Mower
16	532175451	Blade 3-1 Rh 107 CRD	69	532165482	Shaft Asm W/Lwr Brg Rh Thd CRD
17	872140610	Bolt Carr 3/8-16 x1-1/4	84	532156085	Keeper Belt Idler
19	532132827	Bolt Shoulder 5/16-18 Thd Form	116	532137644	Bolt Shoulder
20	532165484	Bolt 3/8-24 x 1.25 Gr8 Ptch Lhthd	117	532133957	Wheel Gage Donut Wide
21	873680500	Nut Crown Lock 5/16-18	118	873930600	Nut Centerlock 3/8-16 Unc
22	532169165	Bracket Idler Sprt RR 107 CRD	119	819121414	Washer 3/8 x 7/8 x 14 Ga.
23	532169166	Bracket Idler Sprt RF 107 CRD	124	872110612	Bolt Carr Sh 3/8-16 x 1-1/2 Gr5
24	532169170	Bracket Suspension LF 107 CRD	130	872110506	Bolt Rdhdsqnk 5/16-18 Unc x 3/4
25	532169171	Bracket Suspension RF 107 CRD	131	532165661	Chute Bagger CRD 92cm
26	532165237	Brace Support Susp Frt CRD	160	532175160	Guide Belt CRD
27	532169172	Bracket Asm. Susp RR 107 CRD	-	532130794	Mandrel Asm Service
28	532169168	Bracket Asm. Susp LR 107 CRD	-	532165579	Mandrel Asm CRD Lh Threads SVC
30	532157722	Screw Thd Rolling Washer Head	-	532175842	Deck Mower Complete
31	532129963	Washer Spacer Mower Vented			
32	532175707	Mandrel Pulleys			
33	532137266	Nut Flg Top Lock Cntr B 9/16			
34	<b>532176291</b>	Bracket Gauge Wheel Lf 107 CRD			

**NOTE:** All component dimensions given in U.S. inches  
1 inch = 25.4 mm

www.emc-motors.com

# REPAIR PARTS

TRACTOR- -MODEL NO. ICT18A (JICTH18C), PRODUCT NO. 954 13 00-43  
BAGGER

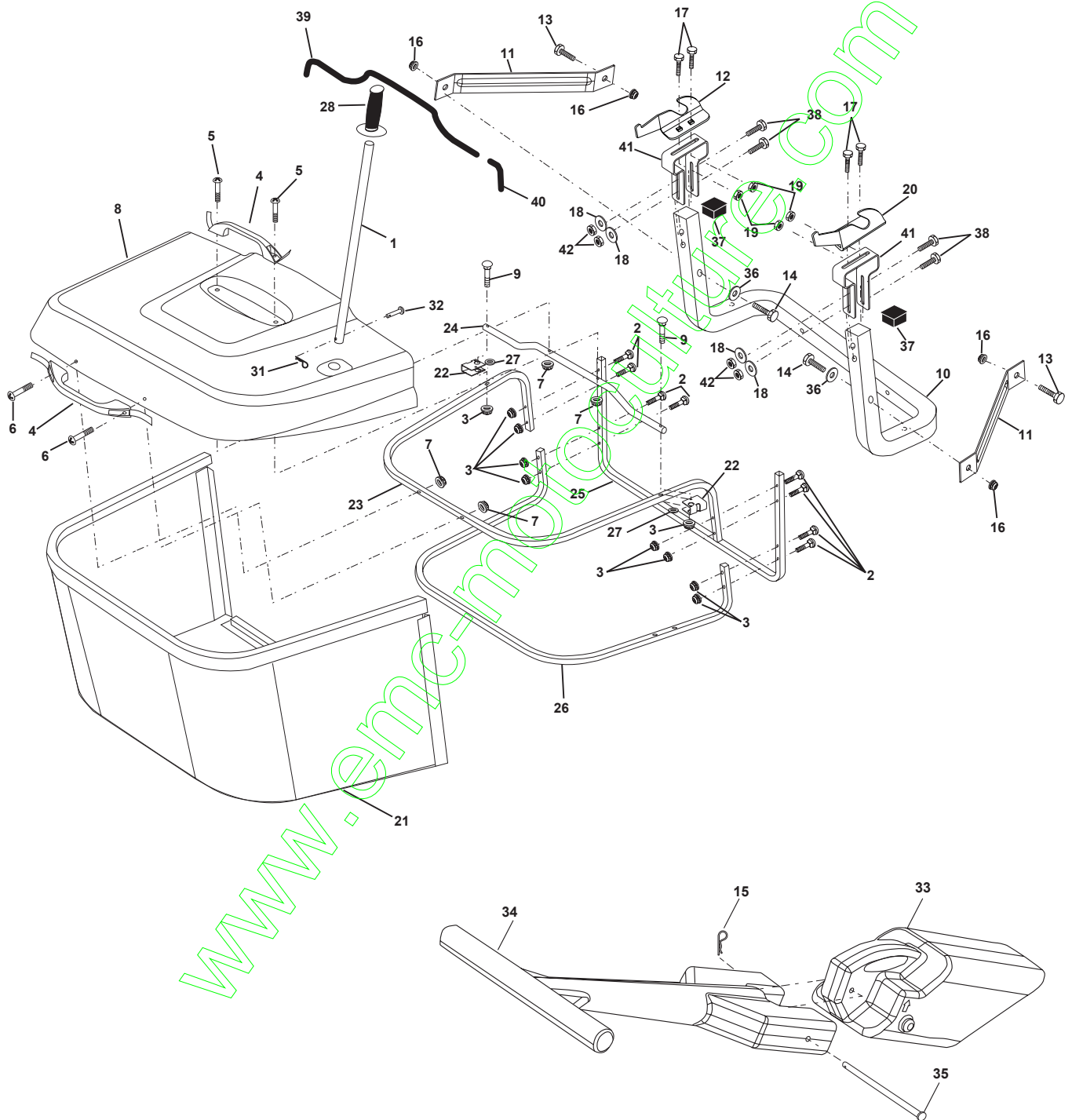

# REPAIR PARTS

TRACTOR- -MODEL NO. ICT18A (JICTH18C), PRODUCT NO. 954 13 00-43  
BAGGER

KEY NO.	PART NO.	DESCRIPTION
1	532170690	Tube Handle Bagger CRD
2	872140416	Bolt Carriage 1/4-20 x 2.0 Gr.5
3	532123976	Nut Lock 1/4 Lge Flg Gr. 5 Zinc
4	532169916	Handle Bagger w/Lvrs Blk CRD
5	874981024	Screw Pan Head #10-24 x 1.50 Blk
6	874981032	Screw Pan Hd
7	873401000	Nut Wiz Lock Hex Serr/Hd 10-24
8	532168871	Cover Bagger Plastic CRD
9	872140418	Bolt Carriage 1/4-20 x 2.25d x Gr.5
10	532169688	Tube Support Bagger CRD
11	532165719	Bracket Support Upper Bag CRD
12	532169685	Bracket Horiz Adj Bagger Lh CRD
13	872110606	Bolt Rdhd Sht Sqnk 3/8-16 x 3/4
14	874520640	Bolt Hex 3/8-16 x 2-1/2 Gr.5
15	532124670	Retainer Spring
16	873900600	Nut Lock Flg 3/8-16 Unc
17	872140506	Bolt Rdhd Sht Sqnk 5/16 -18 Unc x 3/4
18	819111216	Washer 11/32 x 3/4 x 16 Ga.
19	873900500	Nut Lock Hex Flange 5/16-18
20	532169684	Bracket Horiz Adj Bagger Rh CRD
21	532165780	Bag Asm CRD
22	532165781	Bracket Side Bagger CRD
23	532165782	Tube Upper Bagger CRD
24	532165783	Tube Pivot Bagger CRD
25	532165784	Tube Front Bagger CRD
26	532165785	Tube Lower Bagger CRD
27	532169692	Bushing Snap Bagger CRD
28	532170696	Grip Handle Black
31	532124788	Retainer Spring 1" Zinc/Cad
32	532126875	Rivet Rd Hd Drilled 3/8 Dia
33	532169380	Plug Mulcher 107 CRD
34	532165570	Handle Mulcher 92/107 CRD
35	532165572	Pin Mulcher 92/107 CRD
36	819132016	Washer 13/32 x 1-1/4 x 16 Ga.
38	872010520	Bolt 5/16-18 x 2-1/2
37	532175401	Plug Support
39	532169999	Seal 26" (Long)
40	532170000	Seal 7" (Short)
41	532169683	Bracket Vert Adj Bagger CRD
42	873800500	Nut Lock Hex W/Ins 5/16-18 Unc Pl

**NOTE:** All component dimensions given in U.S. inches  
1 inch = 25.4 mm

# TRACTOR- -MODEL NO. ICT18A (JICTH18C), PRODUCT NO. 954 13 00-43 SCHEMATIC

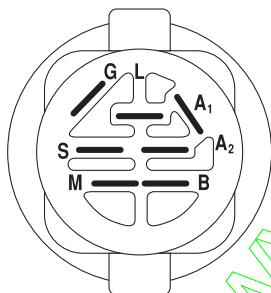
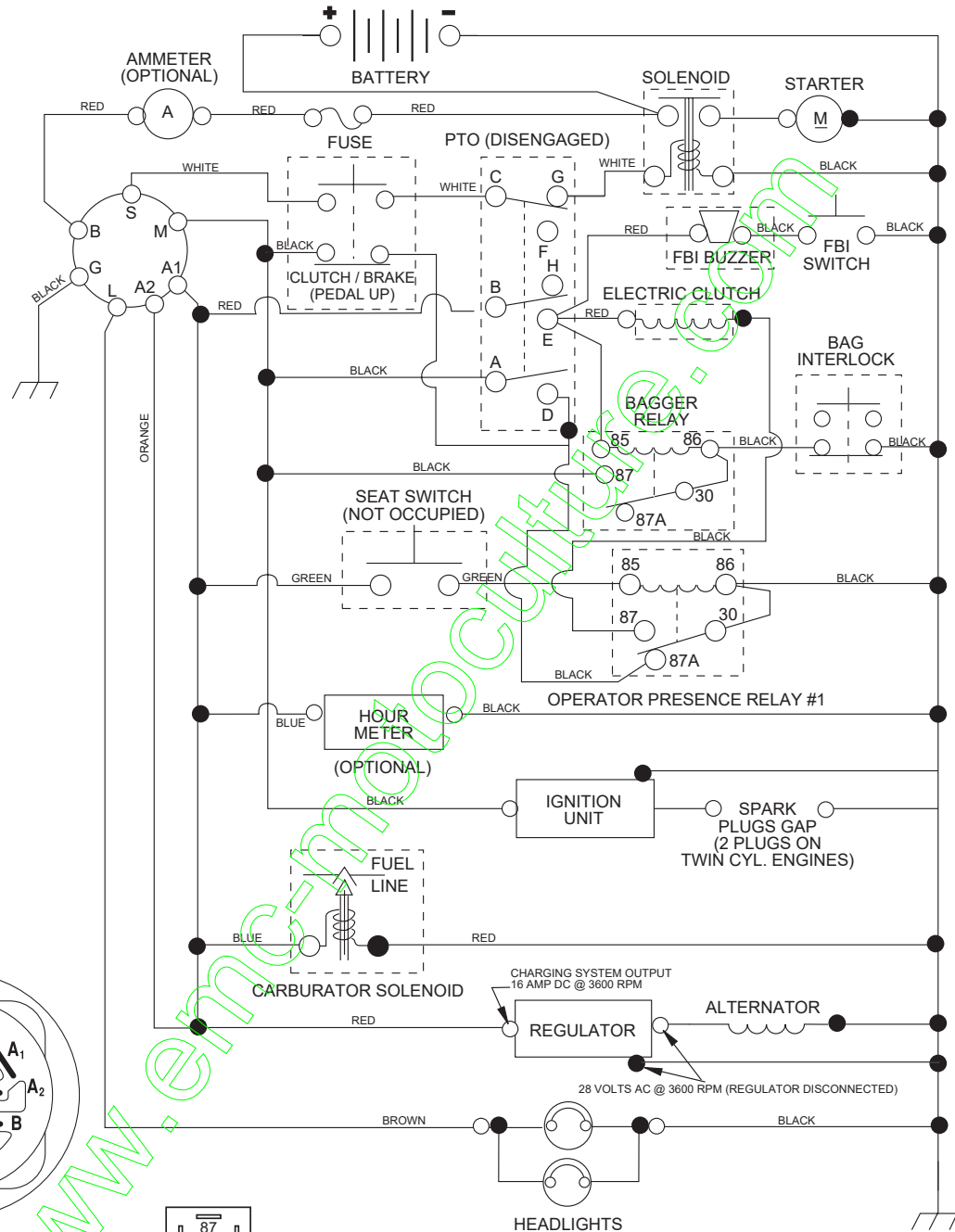

### IGNITION SWITCH

POSITION	CIRCUIT	"MAKE"
OFF	M+G+A1	NONE
RUN/LIGHT	B+A1	A2+L
RUN	B+A1	NONE
START	B + S + A1	NONE



### RELAY

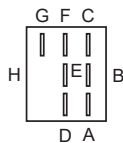

### PTO SWITCH

POSITION	CIRCUIT
OFF	C + G, B + H
ON	C + F, B + E, A + D

● NON-REMOVABLE CONNECTIONS

○ REMOVABLE CONNECTIONS

**WIRING INSULATED CLIPS**  
NOTE: IF WIRING INSULATED CLIPS WERE REMOVED FOR SERVICING OF UNIT, THEY SHOULD BE REPLACED TO PROPERLY SECURE YOUR WIRING.