

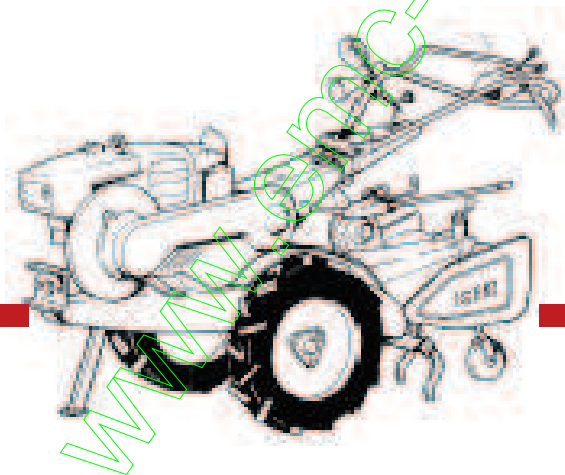

PIECES DETACHEES

Motoculteur



**KS650
KA700**

MOTEUR DIESEL



Yvon Béal 21, Av. de l'Agriculture - B.P. 19
23, Rue Brirot 63018 Clermont-Ferrand Cedex 2
Tel. : 04 73 91 93 51 - Télécopie : 04 73 90 23 11
www.yvonbeal.fr Email : info@yvonbeal.fr
R.C. B 304 973 880 - SIREN 304 973 880 S.A. à direction
et conseil de surveillance au capital de 632 000 Euros

03-000227-050302

ECLATE MOTOCULTEURS KS650 - 750 DIESEL

CONTENTS TABLE DES MATIERES

MOTEUR ES 50C-G POUR KS 650D
ES 70C-G POUR KA 700

ENGINE	Page
Fig. 1 CYLINDER BLOCK Bloc-cylindres	1
Fig. 2 CYLINDER HEAD Culasse	5
Fig. 3 AIR CLEANER & SILENCER Filtre a air & Silencieux	9
Fig. 4 CAMSHAFT Arbre a cames	11
Fig. 5 MAIN BEARING HOUSING & CRANKSHAFT Vilebrequin	13
Fig. 6 PISTON & CONNECTING ROD Piston & Bielle	17
Fig. 7 SIDE COVER & LUB. OIL SYSTEM Pompe a huile	19
Fig. 8 CONDENSER & WATER SUPPLY PORT Condensateur	23
Fig. 9 COOLING FAN DRIVING DEVICE Ventilateur	27
Fig. 10 FUEL INJECTION PUMP Pompe d'injection	31
Fig. 11 FUEL INJECTION VALVE Injecteur-pompe	33
Fig. 12 FUEL OIL SYSTEM Reservoir de combustible	35
Fig. 13 FUEL STRAINER Filtre a combustible	37
Fig. 14 FUEL PIPE Conduit de combustible	38
Fig. 15 GOVERNOR DEVICE Regulateur	39
Fig. 16 STARTING DEVICE Manivelle de lancement	42
Fig. 17 LIGHTING DEVICE Equipment electrique	43
Fig. 18 TOOLS Outils	44

Fig.1 CYLINDER BLOCK
Bloc-cylindres

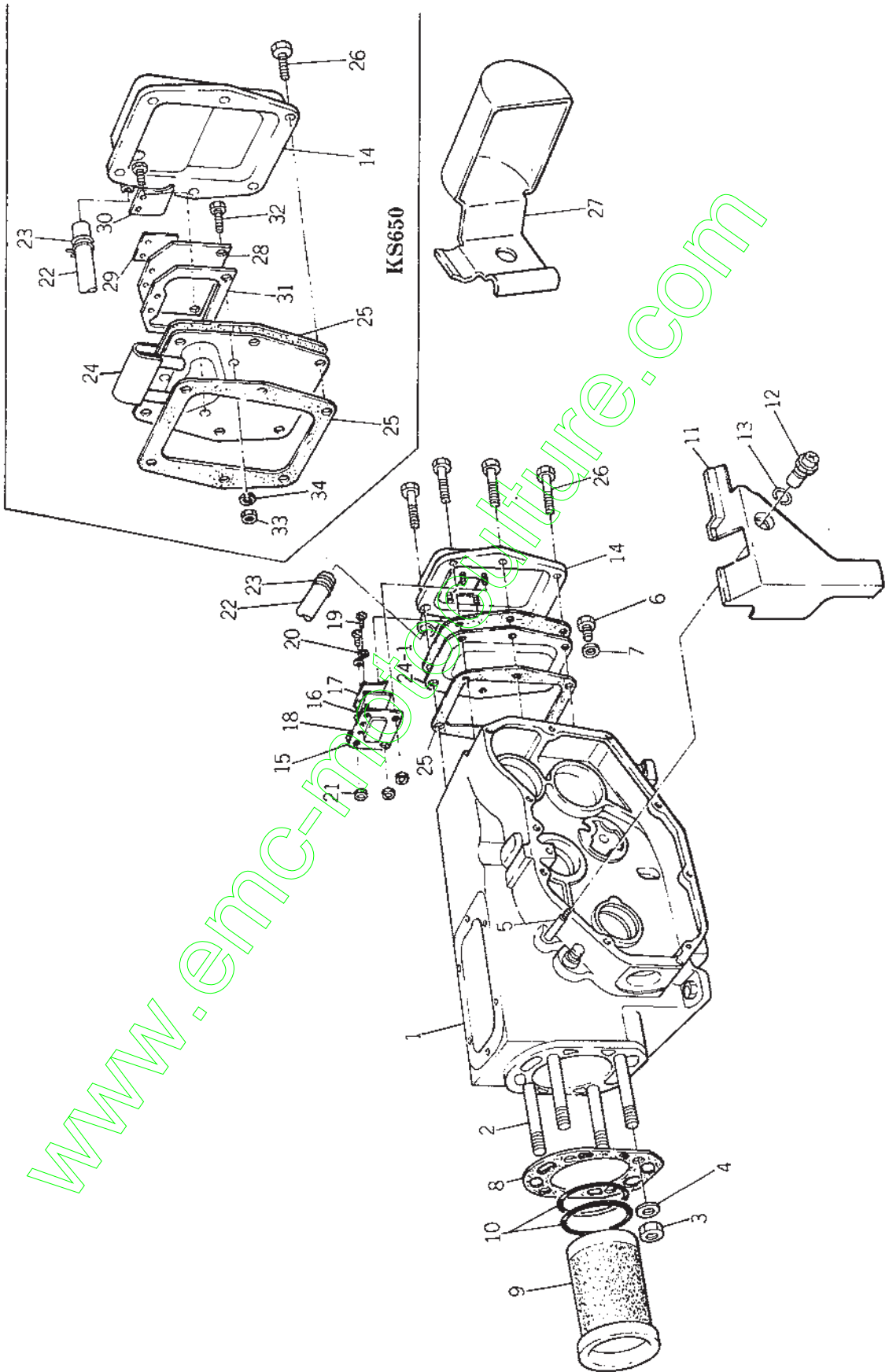

www.emc-motors.com

Ref.No. Réf.Nº.	Parts No. Pièces Nº.	Description Désignation	Model & Q'ty Modél & Quant		Remarks Remarques
			KS650	KA700	
1- 0-1	5986-100-0156-0	BLOCK, CYL ASSY Bloc-cylindres	1		*706100-01560
1- 0-1-1	5986-300-0156-0	BLOCK, CYL ASSY Bloc-cylindres		1	*706300-01560
1- 1		• BLOCK, CYL Bloc-cylindres	1	1	Order assy Δ
1- 2	5904-100-0120-0	• STUD/M12 X 118 Goujon	4		104100-01200
1- 2-1	5904-300-0120-0	• STUD/M14 X 132 Goujon		4	104300-01200
1- 3	5901-158-0122-0	• NUT Erou	4		101158-01220
1- 3-1	5904-300-0122-0	• NUT Erou		4	104300-01220
1- 4	5904-200-0124-0	• WASHER Rondelle	4		104200-01240
1- 4-1	5904-338-0124-0	• WASHER Rondelle		4	103338-01240
1- 5	5962-170-8050-2	• STUD Goujon	1	1	26217-080502
1- 6	5904-200-0169-0	• PLUG, DRAIN Bouchon	1	1	104200-01690
1- 7	5944-141-6000-0	• PACKING, DRAIN PLUG Joint	1	1	23414-160000
		*Included Fig. 5-1, 5-3 ~ 6, 15-11.	1		
1- 8	5904-100-0133-0	PACKING Joint	1		104100-01330
1- 8-1	5904-300-0133-0	PACKING Joint		1	104300-01330
1- 9	5984-100-0190-0	LINER, CYL ASSY Chemise de cylindre	1		704100-01900
1- 9-1	5984-300-0190-0	LINER, CYL ASSY Chemise de cylindre		1	704300-01900
1-10	5901-104-0130-0	• PACKING, CYL/RUBBER Joint	2		101104-01300
1-10-1	5903-288-0130-0	• PACKING, CYL/RUBBER Joint		2	103288-01300
1-11	5984-107-0151-0	BONNET, CYL SIDE ASSY Capot du moteur	1		704107-01510
1-11-1	5984-300-0151-0	BONNET, CYL SIDE ASSY Capot du moteur		1	704300-01510
1-12	5901-147-0177-0	• KNOB, CYL SIDE BONNET Goujon de boîtier	1	1	101147-01770
1-13	5974-100-1137-0	• CIRCLIP, BONNET Collet d'axe	1	1	174100-11370
1- 0-2	5984-104-0152-0	COVER, CYL R. ASSY Couvercle	1		704104-01520
1- 0-2-1	5984-200-0152-0	COVER, CYL R. ASSY Couvercle		1	704200-01520
1-14		• COVER, CYL R. Couvercle	1	1	Δ
1-15	5904-200-0309-0	• BOARD, BAFFLE Anneau de barrage		1	104200-03090
1-16	5901-158-0306-1	• VALVE, CHECK Soupape de retenue		1	101158-03061
1-17	5901-158-0301-1	• PLATE, PRESS Plaque de pression		1	101158-03011
1-18	5904-200-0310-0	• PACKING, BAFFLE BOARD Joint		1	104200-03100
1-19	5965-570-4006-2	• SCREW/M4 X 6 Vis		2	26557-040062
1-20	5932-170-4000-0	• WASHER, SP Rondelle frein		2	22217-040000
1-21	5967-570-5000-0	• NUT/M5 Erou		2	26757-050000
1-22	5940-641-2037-5	• PIPE, AIR BREATHER Tuyau	1	1	23064-120375
1-23	5940-100-1400-0	• CLAMP Collier	1	1	23010-014000
1-24	5904-104-0308-0	PLATE, SHELTER Plaque	1		104104-03080
1-24-1	5904-200-0308-0	PLATE, SHELTER Plaque		1	104200-03080
1-25	5904-200-0149-0	PACKING, R. COVER Joint	2	2	104200-01490

Ref.No. Réf.Nº.	Parts No. Pièces Nº.	Description Désignation	Model & Q'ty Modél & Quant		Remarks Remarques
			KS650	KA700	
1-26	5961-170-6010-9	BOLT/M6 X 10 Vis	6	6	26117-060109
1-27	5906-100-0810-0	HOLDER, HANDLE Support	1	1	106100-08100
1-28	5904-104-0312-0	PLATE, CHECK VALVE FIX Plaque	1		104104-03120
1-29	5904-104-0306-0	VALVE, CHECK Soupape de retenue	1		104104-03060
1-30	5904-104-0311-0	PLATE, PRESS Plaque de pression	1		104104-03110
1-31	5904-104-0313-0	PACKING Joint	1		104104-03130
1-32	5965-570-4010-2	SCREW/M4 X 13 Vis	3		26557-040102
1-33	5967-570-4000-2	NUT/M4 Ecrou	3		26757-040002
1-34	5932-170-4000-0	WASHER, SP/M4 Rondelle frein	3		22217-040000

www.emc-motoculture.com

Fig.2 CYLINDER HEAD

Culasse

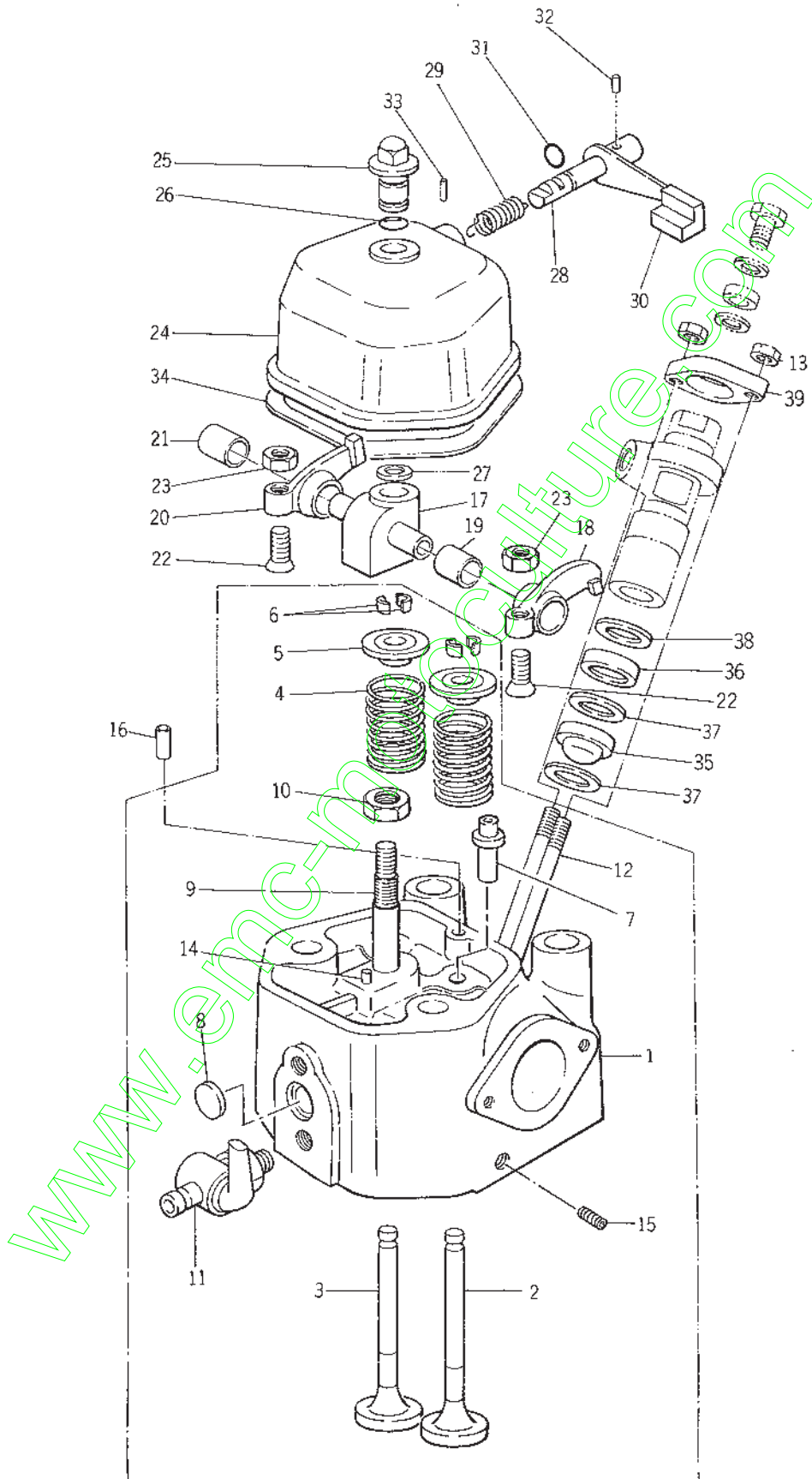

Ref.No. Réf.Nº.	Parts No. Pièces Nº.	Description Désignation	Model & Q'ty Modél & Quant		Remarks Remarques
			KS650	KA700	
2- 1	5984-107-1170-0	HEAD, CYL ASSY Culasse	1		704107-11700
2- 1-1	5984-307-1170-0	HEAD, CYL ASSY Culasse		1	704307-11700
2- 2	5904-100-1110-0	• VALVE, IN Soupape d'admission	1		104100-11100
2- 2-1	5901-218-1110-0	• VALVE, IN Soupape d'admission		1	101218-11100
2- 3	5904-100-1111-0	• VALVE, EXH Soupape d'échappement	1		104100-11110
2- 3-1	5901-218-1111-0	• VALVE, EXH Soupape d'échappement		1	101218-11110
2- 4	5904-100-1112-0	• SPRING, VALVE Ressort de soupape	2		104100-11120
2- 4-1	5904-300-1112-0	• SPRING, VALVE Ressort de soupape		2	104300-11120
2- 5	5904-200-1118-0	• RETAINER, SPRING Cuvette de ressort	2		104200-11180
2- 5-1	5901-158-1118-0	• RETAINER, SPRING Cuvette de ressort		2	101158-11180
2- 6	5901-158-1119-0	• COTTER, VALVE SPRING Bague d'appui	2	2	101158-11190
2- 7	5905-282-1116-0	• GUIDE, VALVE Guide de soupape	2		105282-11160
2- 7-1	5906-300-1116-0	• GUIDE, VALVE Guide de soupape		2	106300-11160
2- 8	5872-312-2000-0	• PLUG Bouchon	1	1	27231-220000
2- 9	5904-100-1135-0	• STUD/M10 X 73 Goujon	1		104100-11350
2- 9-1	5904-200-1135-0	• STUD/M10 x 76 Goujon		1	104200-11350
2-10	5967-321-0000-2	• NUT/M10 Ecrou	1	1	26732-100002
2-11	5904-200-1192-0	• COCK, DRAIN Robinet d'arrêt	1	1	104200-11920
2-12	5962-170-8065-2	• STUD/M8 X 65 Goujon	2		26217-080652
2-12-1	5962-170-8060-2	• STUD/M8 X 60 Goujon		2	26217-080602
2-13	5967-170-8000-2	• NUT/M8 Ecrou	2	2	26717-080002
2-14	5933-510-6001-2	• PIN, SPRING/6 X 12 Goupille élastique	1	1	22351-060012
2-15	5948-710-1000-0	• PLUG Bouchon	1		23871-010000
2-15-1	5948-710-3000-0	• PLUG Bouchon		1	23871-030000
2-16	5933-510-4001-0	• PIN, SPRING Goupille élastique	1	1	22351-040010
2-17	5904-100-1126-0	• SUPPORT Support, d'axe	1		104100-11260
2-17-1	5904-300-1126-0	• SUPPORT Support, d'axe		1	104300-11260
2-18	5984-100-1165-0	ARM, ROCKER IN ASSY Culbuteur	1		704100-11650
2-18-1	5986-300-1165-0	ARM, ROCKER IN ASSY Culbuteur		1	706300-11650
2-19		• BUSH, ROCKER ARM Bague	1	1	△
2-20	5986-100-1166-0	ARM, ROCKER EXH ASSY Culbuteur	1		706100-11660
2-20-1	5984-300-1166-0	ARM, ROCKER EXH ASSY Culbuteur		1	704300-11660
2-21		• BUSH, ROCKER ARM Bague	1	1	△
2-22	5901-158-1123-0	• SCREW/M8 X 30 Vis	2	2	101158-11230
2-23	5967-570-8000-2	• NUT/M8 Ecrou	2	2	26757-080002
2-24	5984-100-1152-0	BONNET, CYL HEAD ASSY Couvre-culasse	1		704100-11520
2-24-1	5984-300-1152-0	BONNET, CYL HEAD ASSY Couvre-culasse		1	704300-11520
2-25	5904-200-1136-0	• KNOB, BONNET Goujon de boîtier	1	1	104200-11360

Ref.No. Réf.Nº.	Parts No. Pièces Nº.	Description Désignation	Model & Q'ty Modél & Quant		Remarks Remarques
			KS650	KA700	
2-26	5904-200-1180-0	• O-RING, BONNET KNOB Joint torique	1	1	104200-11800
2-27	5932-420-0014-0	• CIRCLIP, BONNET KNOB Circlip	1	1	22242-000140
2-28		• SHAFT, DECOMP Axe	1	1	△
2-29	5904-200-0364-1	• SPRING, DECOMP Ressort	1	1	104200-03641
2-30	5904-104-0375-0	• LEVER, DECOMP Lever	1	1	104104-03750
2-31	5953-110-0007-0	• O-RING Joint torique	1	1	24311-000070
2-32	5933-220-3016-0	• PIN, TAPER Goupille	1	1	22322-030160
2-33		• PIN, PARALLEL Goupille	1	1	△
2-34	5904-100-1131-0	PACKING, BONNET Joint	1		104100-11310
2-34-1	5904-300-1131-0	PACKING, BONNET Joint		1	104300-11310
2-35	5904-100-1142-0	CHAMBER, F. PRE-COMBUS Chambre de compression	1		104100-11420
2-35-1	5904-300-1142-0	CHAMBER, F. PRE-COMBUS Chambre de compression		1	104300-11420
2-36	5904-100-1141-0	CHAMBER, R. PRE-COMBUS Chambre de compression	1		104100-11410
2-36-1	5904-300-1141-0	CHAMBER, R. PRE-COMBUS Chambre de compression		1	104300-11410
2-37	5901-158-1145-0	PACKING, CHAMBER Joint	2		101158-11450
2-37-1	5904-300-1145-0	PACKING, CHAMBER Joint		2	104300-11450
2-38	5901-147-1149-0	INSULATOR Poussiere	1		101147-11490
2-38-1	5903-854-1149-0	INSULATOR Poussiere		1	103854-11490
2-39	5901-147-1190-0	FLANGE, F.I. VALVE Flasque de fixation	1	1	101147-11900

Fig.3 AIR CLEANER & SILENCER

Filtre a air & silencieux

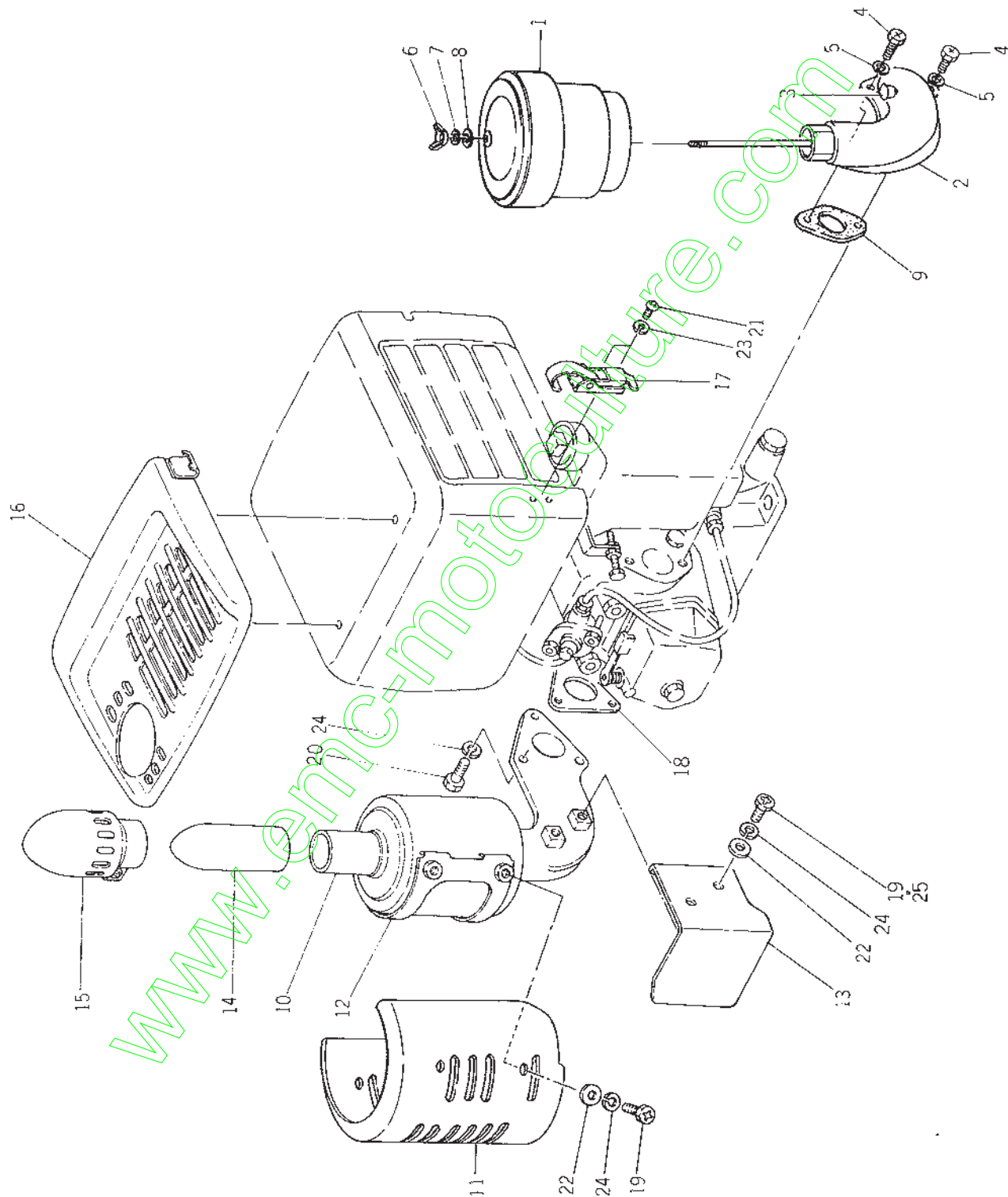

α

Ref.No. Réf.Nº.	Parts No. Pièces Nº.	Description Désignation	Model & Q'ty Modél & Quant		Remarks Remarques
			KS650	KA700	
3- 1	5904-104-1252-0	CLEANER, AIR Filtre a air	1		104104-12520
3- 1-1	5904-300-1252-0	CLEANER, AIR Filtre a air		1	104300-12520
3- 2	5904-100-1209-0	ELBOW, AIR CLEANER Tubulure d'air	1		104100-12090
3- 2-1	5904-300-1209-0	ELBOW, AIR CLEANER Tubulure d'air		1	104300-12090
3- 3	5904-200-1203-0	CUP, GASOLINE Cuve	1	1	104200-12030
3- 4	5961-170-8020-9	BOLT/M8 X 20 Vis	2	2	26117-080209
3- 5	5932-170-8000-0	WASHER, SP/M8 Rondelle frein	2	2	22217-080000
3- 6	5901-147-1255-0	NUT, WING Ecrou a oreilles	1	1	101147-12550
3- 7	5932-170-6000-0	WASHER, SP Rondelle frein	1	1	22217-060000
3- 8	5931-370-6000-0	WASHER Rondelle	1	1	22137-060000
3- 9	5906-100-1205-0	PACKING, AIR CLEANER Joint	1		106100-12050
3- 9-1	5906-300-1205-0	PACKING, AIR CLEANER Joint		1	106300-12050
3-10	5906-230-1350-0	SILENCER Silencieux	1		106230-13500
3-10-1	5906-330-1350-0	SILENCER Silencieux		1	106330-13500
3-11	5906-130-1352-0	COVER, SILENCER Coquille de silencieux	1		106130-13520
3-11-1	5906-330-1352-0	COVER, SILENCER Coquille de silencieux		1	106330-13520
3-12	5906-330-1353-0	STAY, BODY COVER Support		1	106330-13530
3-13	5906-230-1356-0	COVER, ELBOW Coquille	1		106230-13560
3-13-1	5906-330-1356-0	COVER, ELBOW Coquille		1	106330-13560
3-14	5906-330-1357-0	ELBOW, SILENCER Tubulure	1	1	106330-13570
3-15	5906-330-1359-0	COVER, ELBOW SILENCER Coquille	1	1	106330-13590
3-16	5906-230-1370-0	COVER, SILENCER Coquille	1		106230-13700
3-16-1	5906-330-1370-0	COVER, SILENCER Coquille		1	106330-13700
3-17	5906-530-1371-0	CLAMP, COVER Gâtelier	2	2	106530-13710
3-18	5904-100-1320-0	PACKING, GASKET Joint	1		104100-13200
3-18-1	5904-300-1320-0	PACKING, GASKET Joint		1	104300-13200
3-19	5961-170-8012-9	BOLT/M8 X 12 Vis	4	6	26117-080129
3-20	5961-170-8018-9	BOLT/M8 X 18 Vis	2	3	26117-080189
3-21	5965-570-5010-2	SCREW/M5 X 10 Vis	4	4	26557-050102
3-22	5931-170-8000-0	WASHER Rondelle	6	6	22117-080000
3-23	5932-120-5000-0	WASHER, SP Rondelle frein	4	4	22212-050000
3-24	5932-120-8000-0	WASHER, SP Rondelle frein	8	9	22212-080000
3-25	5961-170-8010-2	BOLT/M8 X 10 Vis	2		26117-080102

Ref.No. Réf.Nº.	Parts No. Pièces Nº.	Description Désignation	Model & Q'ty Modél & Quant		Remarks Remarques
			KS650	KA700	
4- 1	5904-100-1401-0	CAMSHAFT Arbre a cames	1		104100-14010
4- 1-1	5904-300-1401-0	CAMSHAFT Arbre a cames		1	104300-14010
4- 2	5904-100-1410-0	GEAR, CAMSHAFT Pignon entraine	1		104100-14100
4- 2-1	5904-300-1410-0	GEAR, CAMSHAFT Pignon entraine		1	104300-14100
4- 3	5904-200-1409-0	CAM, FUEL Came	1		104200-14090
4- 3-1	5904-300-1409-0	CAM, FUEL Came		1	104300-14090
4- 4	5903-338-1419-0	KEY, CAM GEAR Clavette	1		103338-14190
4- 4-1	5904-100-1419-0	KEY, CAM GEAR Clavette		1	104100-14190
4- 5	5904-200-1420-0	TAPPET, VALVE Poussoir	2		104200-14200
4- 5-1	5903-338-1420-0	TAPPET, VALVE Poussoir		2	103338-14200
4- 6	5904-100-1440-0	ROD, VALVE PUSH Tige de poussoir	2		104100-14400
4- 6-1	5904-300-1440-0	ROD, VALVE PUSH Tige de poussoir		2	104300-14400
4- 7	5951-010-6004-4	BEARING Roulement radial	1		24101-060044
4- 7-1	5951-010-6006-4	BEARING Roulement radial		1	24101-060064
4- 8	5965-870-8012-2	SCREW/M8 X 12 Vis	1	1	26587-080122
4- 9	5904-200-5401-0	MOUNT, FUEL INJ PUMP Flasque de fixation	1	1	104200-54010
4-10	5904-200-5423-0	SHIM SET, ADJ Cok	1	1	104200-54230
4-11	5984-200-5450-0	GUIDE, ROLLER ASSY Galet de poussoir	1	1	704200-54500
4-12	5974-100-5411-0	• ROLLER Galet	1	1	174100-54110
4-13	5974-100-5412-0	• PIN, ROLLER Goupille	1	1	174100-54120
4-14	5974-100-5418-0	STOPPER, ROLLER GUIDE Pastille	1	1	174100-54180
4-15	5904-200-7640-0	GEAR, STARTING Pignon	1		104200-76400
4-15-1	5904-300-7640-1	GEAR, STARTING Pignon		1	104300-76401
4-16	5904-300-7646-0	NUT, STARTING GEAR Eccrou	1	1	104300-76460

Fig.5 MAIN BEARING HOUSING & CRANKSHAFT
Vilebrequin

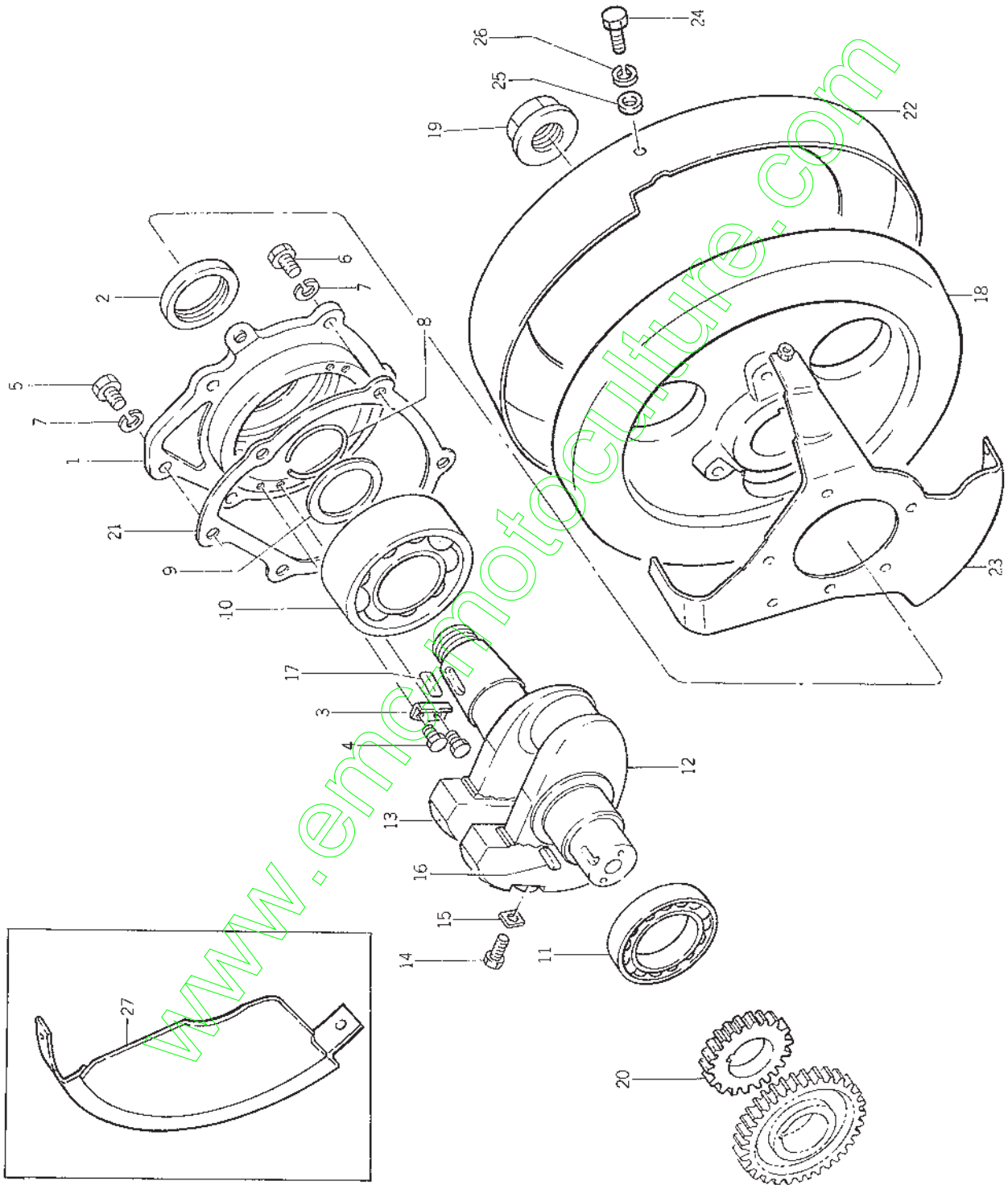

Ref.No. Réf.Nº	Parts No. Pièces Nº.	Description Désignation	Model & Q'ty Modél & Quant		Remarks Remarques
			KS630	KA700	
5- 1	5986-100-0250-0	HOUSING, BEARING ASSY Support de palier	1		706100-02500
5- 1-1	5986-300-0250-0	HOUSING, BEARING ASSY Support de palier		1	706300-02500
5- 2	5901-158-0222-0	* SEAL, OIL Bague d'étanchéité	1		101158-02220
5- 2-1	5903-288-0222-0	* SEAL, OIL Bague d'étanchéité		1	103288-02220
5- 3	5906-100-0232-0	HOLDER, BEARING Pastille	1		106100-02320
5- 3-1	5906-300-0232-0	HOLDER, BEARING Pastille		2	106300-02320
5- 4	5961-160-5008-2	BOLT/M5 X 8 Vis	4		26116-050082
5- 4-1	5961-160-6010-2	BOLT/M6 X 10 Vis		4	26116-060102
5- 5	5961-160-8022-2	BOLT/M8 X 22 Vis	5	5	26116-080222
5- 6	5961-160-8025-2	BOLT/M8 X 25 Vis	1		26116-080252
5- 6-1	5961-160-8028-2	BOLT/M8 X 28 Vis	1		26116-080282
5- 7	5932-170-8000-0	WASHER, SP Rondelle frein	6	6	22217-080000
5- 8	5906-100-0234-0	RING, SNAP Collet d'axe	1		106100-02340
5- 8-1	5906-300-0234-0	RING, SNAP Collet d'axe		1	106300-02340
5- 9	5906-100-0297-0	WASHER Rondelle	1		106100-02970
5- 9-1	5906-300-0297-0	WASHER Rondelle		1	106300-02970
5-10	5906-100-0230-0	BEARING, BALL/6308 Roulement radial	1		106100-02300
5-10-1	5906-300-0230-0	BEARING, BALL/6310 Roulement radial		1	106300-02300
5-11	5906-100-0231-0	BEARING, ROLLER/NF208 Roulement radial	1		106100-02310
5-11-1	5906-300-0231-0	BEARING, ROLLER/NF210 Roulement radial		1	106300-02310
5-12	5986-130-2170-0	CRANKSHAFT ASSY Vilebrequin	1		706130-21700
5-12-1	5986-330-2170-0	CRANKSHAFT ASSY Vilebrequin		1	706330-21700
5-13	5906-330-2170-0	* WEIGHT, BALANCE Contrepoids	2		106130-21100
5-13-1	5906-330-2170-0	* WEIGHT, BALANCE Contrepoids		1	106330-21700 Flywheel side
	5906-330-2171-0	* WEIGHT, BALANCE Contrepoids		1	106330-21710 Driving side
5-14	5961-521-0040-1	* BOLT/M10 X 40 Vis	2	2	26152-100401
5-15	5903-338-2114-0	* WASHER Rondelle	2	2	103338-21140
5-16	5901-158-2129-0	* KEY, CRANKSHAFT GEAR Clavette	1		101158-21290
5-16-1	5901-300-2129-0	* KEY, CRANKSHAFT GEAR Clavette		1	101300-21290
5-17	5935-121-0026-0	* KEY, FLYWHEEL Clavette	1		22512-100260
5-17-1	5903-338-2119-0	* KEY, FLYWHEEL Clavette		1	103338-21190
5-18	5906-100-2140-0	* FLYWHEEL Volant	1		106100-21400
5-18-1	5906-300-2140-0	* FLYWHEEL Volant		1	106300-21400
5-19	5904-200-2153-0	NUT, END Ecrou	1		104200-21530
5-19-1	5906-330-2153-0	NUT, END Ecrou		1	106330-21530
5-20	5906-100-2120-0	GEAR, CRANKSHAFT Pignon	1		106100-21200
5-20-1	5904-300-2120-1	GEAR, CRANKSHAFT Pignony		1	104300-21201
5-21	5904-400-0202-0	PACKING, HOUSING Joint		1	104400-02020

Ref.No. Réf.Nº.	Parts No. Pièces Nº.	Description Désignation	Model & Q'ty Modél & Quant		Remarks Remarques
			KS650	KA700	
5-22	5906-130-2130-0	COVER Couvercle	1		106130-21300
5-22-1	5906-330-2130-0	COVER Couvercle		1	106330-21300
5-23	5906-130-2131-0	SUPPORT, FLYWHEEL COVER Support	1		106130-21310
5-23-1	5906-330-2131-0	SUPPORT, FLYWHEEL COVER Support		1	106330-21310
5-24	5961-170-8014-2	BOLT, COVER/M8 X 14 Vis	4	4	26117-080142
5-25	5931-370-8000-0	WASHER Rondelle	4	4	22137-080000
5-26	5932-120-8000-0	WASHER, SP/M8 Rondelle frein	4	4	22212-080000
5-27	5906-130-2186-0	COVER, FLYWHEEL B Couvercle	1		106130-21860
5-27-1	5860-330-2186-0	COVER, FLYWHEEL B Couvercle		1	106330-21860

www.emc-motoculture.com

Fig.6 PISTON & CONNECTING ROD

Piston & bielle

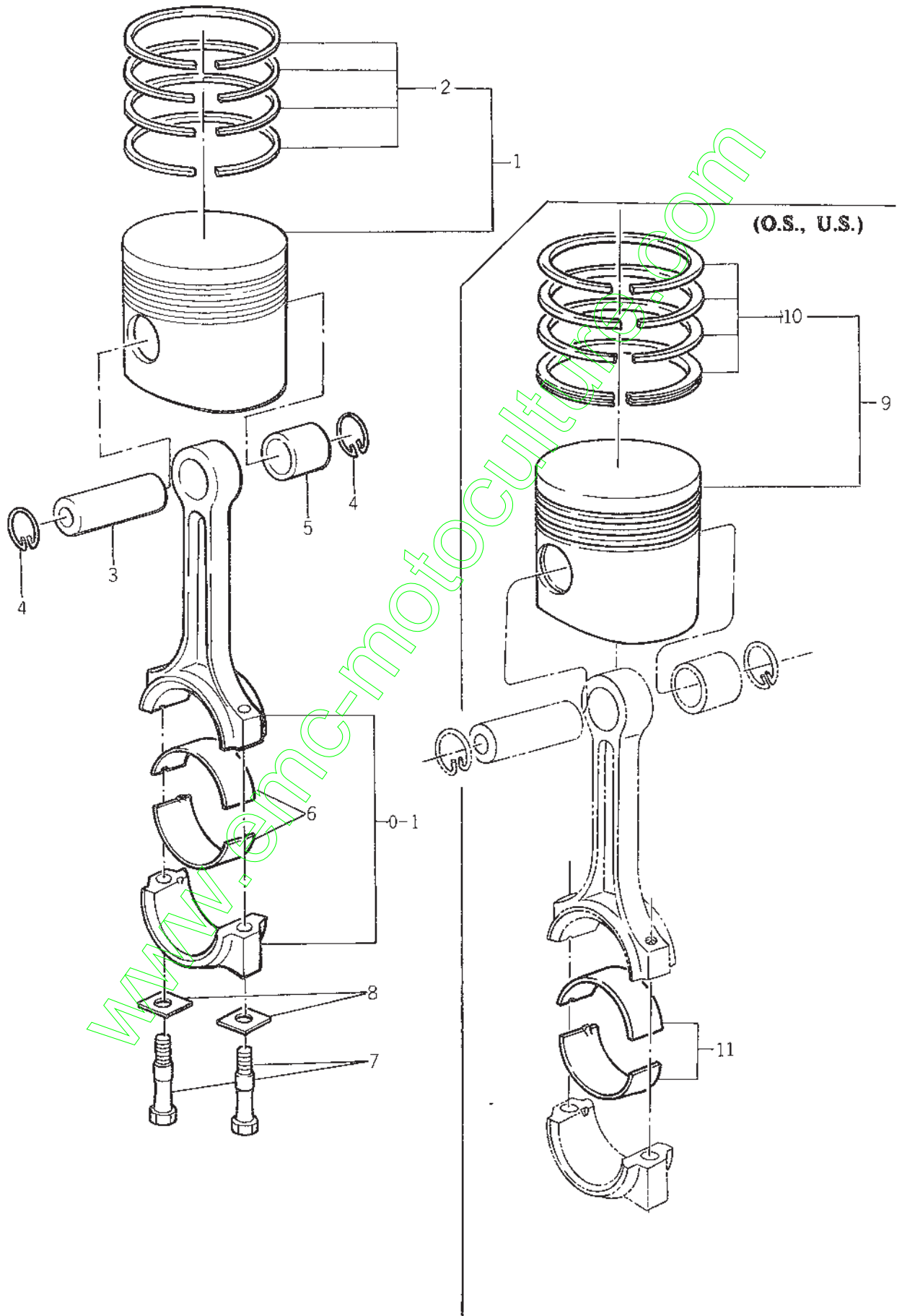

Ref.No. Réf.No.	Parts No. Pièces No.	Description Désignation	Model & Q'ty Modél & Quant		Remarks Remarques
			KS650	KA700	
6- 1	5904-100-2209-0	PISTON ASS'Y Piston	1		104100-22090
6- 1-1	5904-300-2209-0	PISTON ASS'Y Piston		1	104300-22090
6- 2	5984-100-2250-0	* RING, PISTON SET Segmentation	1		704100-22500
6- 2-1	5984-300-2250-0	* RING, PISTON SET Segmentation		1	704300-22500
6- 3	5904-100-2230-0	PIN, PISTON Axe de piston	1		104100-22300
6- 3-1	5903-338-2230-0	PIN, PISTON Axe de piston		1	103338-22300
6- 4	5901-158-2240-0	CIRCLIP, PISTON PIN Collet d'axe	2		101158-22400
6- 4-1	5903-338-2240-0	CIRCLIP, PISTON PIN Collet d'axe		2	103338-22400
6- 0-1	5984-100-2310-0	ROD, CONN ASS'Y Bielle	1		704100-23100
6- 0-1-1	5984-300-2310-0	ROD, CONN ASS'Y Bielle		1	704300-23100
6- 5	5904-100-2310-0	* BUSH, PISTON PIN Bague de pied de bielle			104100-23100
6- 5-1	5903-338-2310-0	* BUSH, PISTON PIN Bague de pied de bielle		1	103338-23100
6- 6	5904-100-2334-0	* BEARING, CONN ROD Coussinet de tete de bielle			104100-23340
6- 6-1	5903-288-2330-0	* BEARING, CONN ROD Coussinet de tete de bielle		1	103288-23300
6- 7	5904-200-2320-0	* BOLT, CONN ROD Vis	2		104200-23200
6- 7-1	5904-300-2320-0	* BOLT, CONN ROD Vis		2	104300-23200
6- 8	5904-200-2321-0	* WASHER, ROD BOLT Rondelle	2		104200-23210
6- 8-1	5904-300-2321-0	* WASHER, ROD BOLT Rondelle		2	104300-23210
6- 9	5904-100-2247-0	PISTON ASSY/0.25 OS Piston	1		104100-22470
6- 9-1	5904-100-2248-0	PISTON ASSY/0.5 OS Piston	1		104100-22480
6- 9-2	5904-300-2247-0	PISTON ASSY/0.25 OS Piston		1	104300-22470
6- 9-3	5904-300-2248-0	PISTON ASSY/0.5 OS Piston		1	104300-22480
6-10	5984-100-2257-0	* RING, PISTON SET/0.25 OS Segmentation	1		704100-22570
6-10-1	5984-100-2254-0	* RING, PISTON SET/0.5 OS Segmentation	1		704100-22540
6-10-2	5984-300-2257-0	* RING, PISTON SET/0.25 OS Segmentation		1	704300-22570
6-10-3	5984-300-2254-0	* RING, PISTON SET/0.5 OS Segmentation		1	704300-22540
6-11	5904-100-2335-0	BEARING, CONN ROD/0.25 Bielle	1		104100-23350
6-11-1	5904-100-2336-0	BEARING, CONN ROD/0.50 Bielle	1		104100-23360
6-11-2	5904-300-2335-0	BEARING, CONN ROD/0.25 Bielle		1	104300-23350
6-11-3	5904-300-2336-0	BEARING, CONN ROD/0.50 Bielle		1	104300-23360

Fig.7 SIDE COVER & LUB. OIL SYSTEM

Pompe a huile

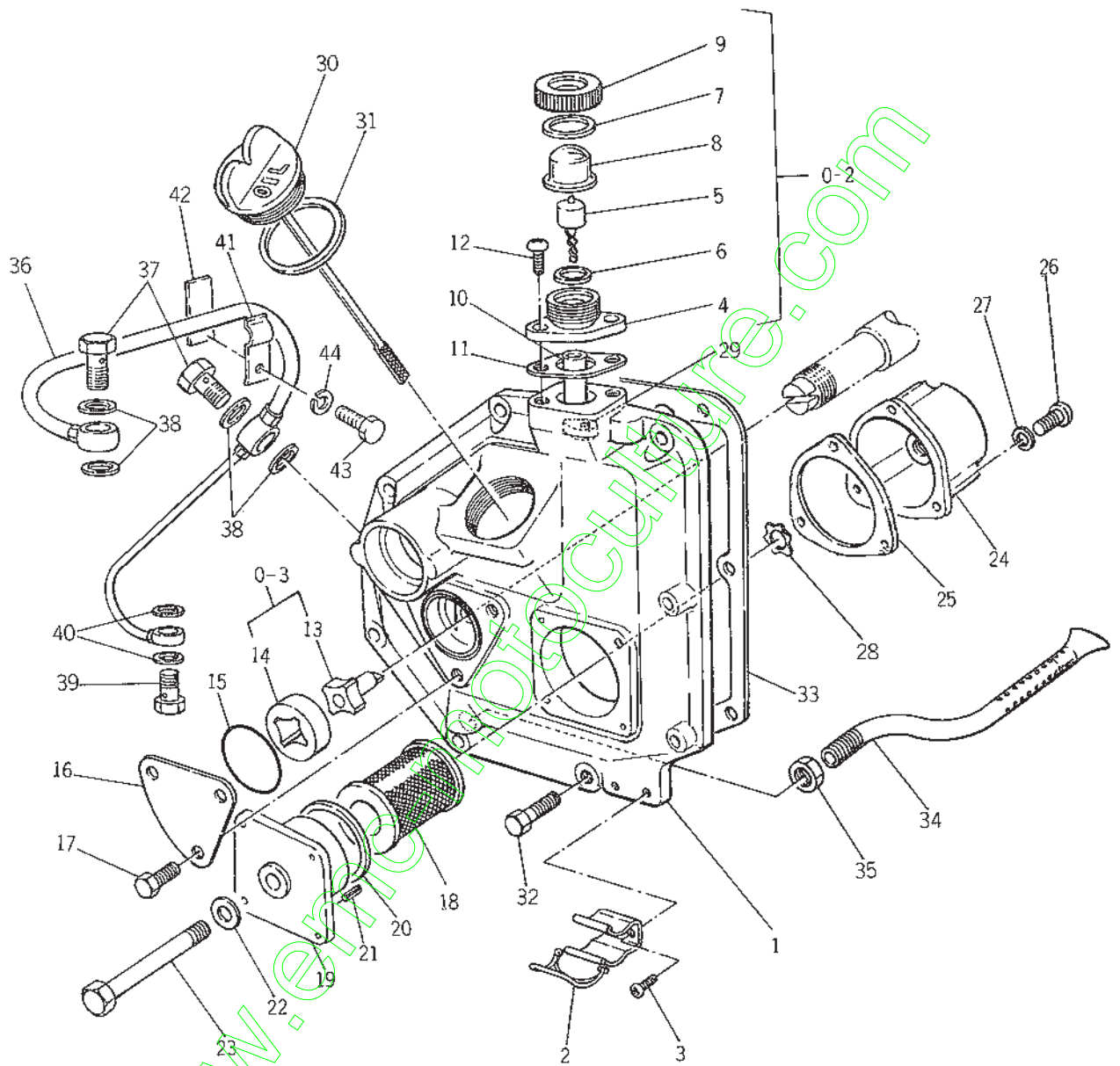

Ref.No. Réf.No.	Parts No. Pièces No.	Description Désignation	Model & Qty Modél & Quant		Remarks Remarques
			KS650	KA700	
7- 0-1	5986-100-0150-0	COVER, CYL SIDE ASSY Couvercle	1		706100-01500
7- 0-1-1	5986-300-0150-0	COVER, CYL SIDE ASSY Couvercle		1	706300-01500
7- 1		•COVER, CYL SIDE Couvercle	1	1	△
7- 2	5984-200-0851-0	•CLAMP, START HANDLE Collier	1	1	704200-08510
7- 3	5965-570-6008-2	•SCREW/M6 x 8 Vis	2	2	26557-060082
7- 0-2	5984-200-3450-0	•OILER ASSY Jauge de pression d'huile	1	1	704200-34500
7- 4	5904-200-3450-0	•• BODY, OILER Tubulure	1	1	104200-34500
7- 5	5901-200-3452-0	•• ROTOR, OILER Echelle	1	1	101200-34520
7- 6	5972-200-3456-0	•• PACKING, OILER GLASS Joint	1	1	172200-34560
7- 7	5972-200-3455-0	•• PACKING, OILER GLASS Joint	1	1	172200-34550
7- 8	5901-200-3453-0	•• GLASS, OILER Cuve	1	1	101200-34530
7- 9	5903-884-3454-0	•• RETAINER, OILER GLASS Capuchon	1	1	103884-34540
7-10	5901-200-3459-0	•• GUIDE, OILER ROTOR Guidage	1	1	101200-34590
7-11	5904-200-3451-0	•PACKING, OILER BODY Joint	1	1	104200-34510
7-12	5965-570-6016-2	•SCREW/M6 x 16 Vis	2	2	26557-060162
7- 0-3	5904-300-3215-0	• ROTOR ASSY Pignon de pompe	1		104300-32150
7- 0-3-1	5901-304-3252-0	• ROTOR ASSY Pignon de pompe		1	101304-32520
7-13		•• ROTOR, IN ASSY Pignon	1	1	△
7-14		•• ROTOR, OUT Pignon	1	1	△
7-15	5903-338-3257-0	•O-RING Joint torique	1	1	103338-32570
7-16	5903-338-3207-0	•COVER, LUB OIL PUMP Couvercle de pompe a huile	1	1	103338-32070
7-17	5961-170-6010-2	•BOLT/M6 x 10 Vis	3	3	26117-060102
7-18	5904-200-3515-0	•ELEMENT, LUB OIL Cartouche filtre	1	1	104200-35150
7-19	5904-200-3526-0	•COVER, OIL STRAINER Couvercle	1	1	104200-35260
7-20	5904-200-3528-0	•O-RING Joint torique	1	1	104200-35280
7-21	5933-510-2000-8	•PIN, SPRING Goupille elastique	1	1	22351-020008
7-22	5944-140-8000-0	•PACKING Joint	1	1	23414-080000
7-23	5904-200-3530-0	•BOLT/M8 x 65.5 Vis	1	1	104200-35300
7-24	5904-200-3527-0	•BOWL, OIL STRAINER Boitier de filtre	1	1	104200-35270
7-25	5904-200-3512-0	•PACKING, BOWL Joint	1	1	104200-35120
7-26	5965-570-6014-2	•SCREW/M6 x 14 Vis	2	2	26557-060142
7-27	5932-170-6000-0	•WASHER, SP/M6 Rondelle frein	2	2	22217-060000
7-28	5904-200-5529-0	•WASHER Rondelle	1	1	104200-55290
7-29	5904-100-3460-0	•PLATE, OIL CONTROL Plaque Included Fig. 22-1 ~ 22-12	1	1	104100-34600
7-30	5904-100-0175-0	CAP, OIL GAUGE Jauge d'huile	1		104100-01750
7-30-1	5904-300-0175-0	CAP, OIL GAUGE Jauge d'huile		1	104300-01750
7-31	5901-104-0176-0	PACKING, OIL PIPE Joint	1	1	101104-01760

Ref.No. Réf.Nº.	Parts No. Pièces N°.	Description Désignation	Model & Q'ty Modél & Quant		Remarks Remarques
			KS650	KA700	
7-32	5961-160-6018-2	BOLT/M6 x 18 Vis	7	6	26116-060182
	5961-160-6022-2	BOLT/M6 x 22 Vis		1	26116-060222
	5961-160-6020-2	BOLT/M6 x 20 Vis	1	1	26116-060202
7-33	5904-100-0141-0	PACKING, SIDE COVER Joint	1		104100-01410
7-33-1	5904-300-0141-0	PACKING, SIDE COVER Joint		1	104300-01410
7-34	5906-100-3509-0	PIPE, OIL INLET Tuyau d'aspiration	1		106100-35090
7-34-1	5906-300-3509-0	PIPE, OIL INLET Tuyau d'aspiration		1	106300-35090
7-35	5904-200-3507-0	NUT/PT 1/8 Ecrou	1	1	104200-35070
7-36	5906-100-3920-0	PIPE, LUB OIL Conduit	1		106100-39200
7-36-1	5906-300-3920-0	PIPE, LUB OIL Conduit		1	106300-39200
7-37	5903-854-3914-0	BOLT, OIL PIPE JOINT Vis	2	2	103854-39140 Cyl. head side
7-38	5944-141-2000-0	PACKING Joint	4	4	23414-120000
7-39	5901-147-5981-0	BOLT, OIL PIPE JOINT Vis	1	1	101147-59810 Cyl. head side
7-40	5944-140-8000-0	PACKING Joint	2	2	23414-080000 Cyl. head side
7-41	5906-300-3915-0	RETAINER, OIL PIPE Coffier	1	1	106300-39150
7-42	5906-300-3914-0	SPACER, PIPE RETAINER Flaquette de support	1	1	106300-39140
7-43	5961-170-8016-2	BOLT/M8 x 16 Vis	1	1	26117-080162
7-44	5932-120-8000-0	WASHER, SP/M8 Rondelle frein	1	1	22212-080000

Fig.8 CONDENSER & WATER SUPPLY PORT

Condensateur

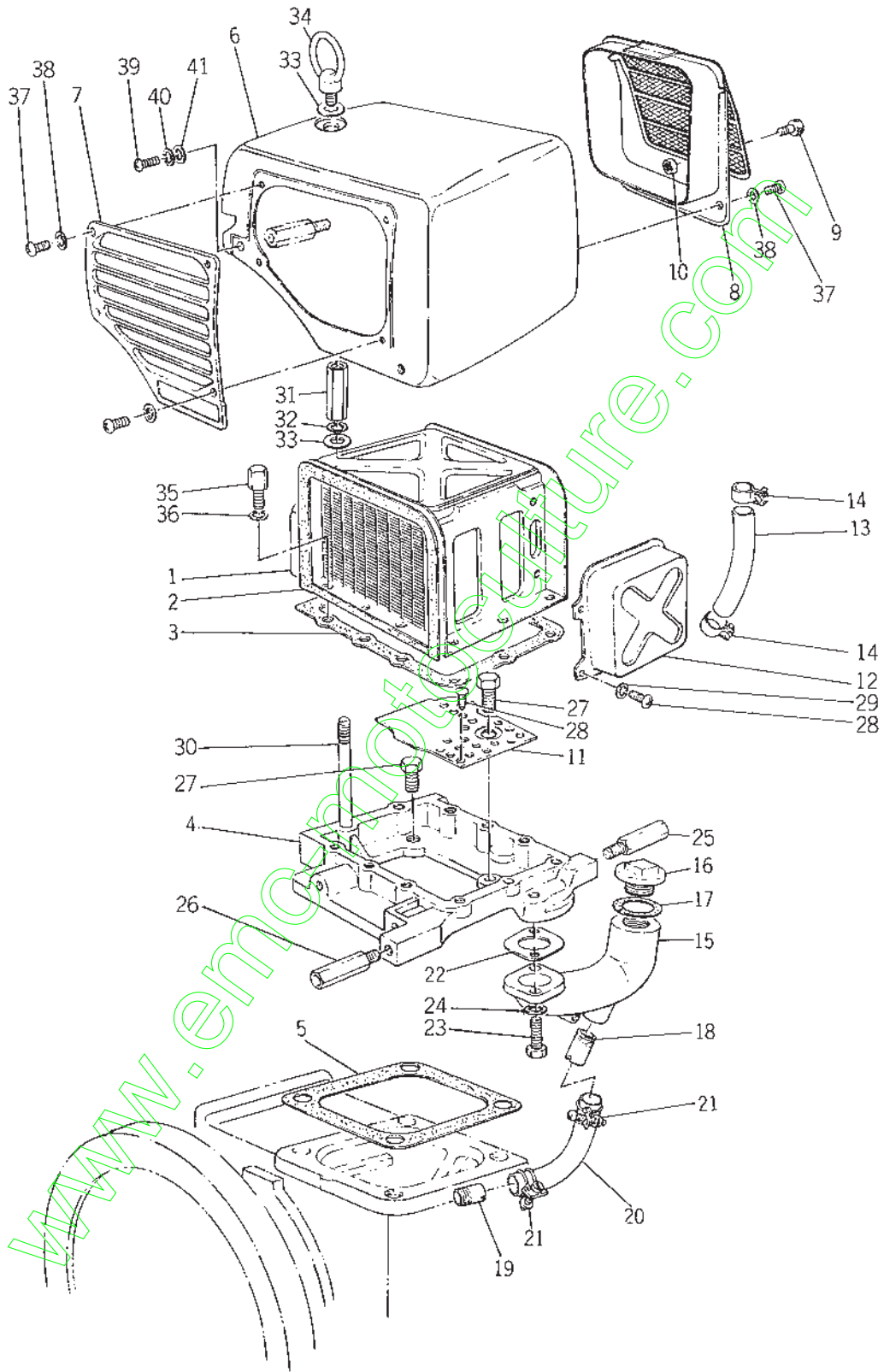

Ref.No. Réf.Nº.	Parts No. Pièces Nº.	Description Désignation	Model & Q'ty Modél & Quant		Remarks Remarques
			KS650	KA700	
8- 1	5904-107-4450-0	CONDENSER ASSY Condensateur	1		104107-44500
8- 1-1	5904-407-4450-0	CONDENSER ASSY Condensateur		1	104407-44500
8- 2	5904-607-4457-0	• SPONGE, CONDENSER Anneau de barrage	2	2	104607-44570
8- 3	5904-207-4461-0	PACKING, CONDENSER Joint	1		104207-44610
8- 3-1	5904-407-4461-0	PACKING, CONDENSER Joint		1	104407-44610
8- 4	5904-107-4430-0	MOUNT, CONDENSER Flasque de fixation	1		104107-44300
8- 4-1	5904-407-4430-0	MOUNT, CONDENSER Flasque de fixation		1	104407-44300
8- 5	5904-100-4405-0	PACKING, MOUNT Joint	1		104100-44050
8- 5-1	5904-300-4405-0	PACKING, MOUNT Joint		1	104300-44050
8- 6	5904-108-4425-0	COVER, CONDENSER Couvercle	1		104108-44250
8- 6-1	5904-308-4425-0	COVER, CONDENSER Couvercle		1	104308-44250
8- 7	5906-100-4433-0	SCREEN, FLYWHEEL SIDE Couvercle	1		106100-44330
8- 7-1	5906-300-4433-0	SCREEN, FLYWHEEL SIDE Couvercle		1	106300-44330
8- 8	5904-107-4432-0	SCREEN, CONTROL SIDE Couvercle	1		104107-44320
8- 8-1	5904-407-4432-0	SCREEN, CONTROL SIDE Couvercle		1	104407-44320
8- 9	5904-407-4438-0	• KNOB, SCREEN Goujon de boitier	1	1	104407-44380
8-10	5932-720-0004-0	• CIRCLIP Collet d'axe	1	1	22272-000040
8-11	5904-107-4465-0	SEPARATOR, AIR-WATER Separateur	1		104107-44650
8-11-1	5904-407-4465-0	SEPARATOR, AIR-WATER Separateur		1	104407-44650
8-12	5904-407-4463-1	TANK, CONDENSER Reservoir	1	1	104407-44631
8-13	5904-407-4464-0	PIPE/RUBBER Tuyau	1	1	104407-44640
8-14	5903-854-4468-0	CLAMP Collier	1	1	103854-44680
8-15	5984-107-4454-0	PORT, WATER ASSY Orifice de remplissage	1		704107-44540
8-15-1	5984-407-4454-0	PORT, WATER ASSY Orifice de remplissage		1	704407-44540
8-16	5906-583-4496-0	• CAP, WATER PORT Bouchon	1	1	106583-44960
8-17	5902-377-4440-0	• PACKING, CAP Joint	1	1	102377-44400
8-18	5904-107-4448-0	♦ JOINT Raccord	1		104107-44480
8-18-1	5904-407-4448-0	• JOINT Raccord		1	104407-44480
8-19	5904-107-4448-0	JOINT Raccord	1		104107-44480
8-19-1	5904-407-4448-0	JOINT Raccord		1	104407-44480
8-20	5904-107-4449-0	PIPE/RUBBER Tubulure	1		104107-44490
8-20-1	5904-407-4449-0	PIPE/RUBBER Tubulure		1	104407-44490
8-21	5940-100-1700-0	CLAMP Collier	2		23010-017000
8-21-1	5940-100-2500-0	CLAMP Collier		2	23010-025000
8-22	5904-407-4442-0	PACKING, WATER PORT Joint	1	1	104407-44420
8-23	5961-170-8022-9	BOLT/M8 X 22 Vis	2	2	26117-080229
8-24	5932-170-8000-0	WASHER, SP Rondelle frein	2	2	22217-080000
8-25	5904-407-4426-0	BOLT, A/L = 39 Vis		2	104407-44260

Ref.No. Réf.Nº.	Parts No. Pièces N°.	Description Désignation	Model & Q'ty Modèl & Quant		Remarks Remarques
			KS650	KA700	
8-26	5904-407-4427-0	BOLT, B/L = 58 Vis	2	2	104407-44270
8-27	5961-170-8020-9	BOLT/M8 X 20 Vis	4		26117-080209
8-27-1	5961-171-0025-2	BOLT/M10 X 25 Vis		4	26117-100252
8-28	5965-570-6010-2	BOLT/M6 X 10 Vis	5	5	26557-060102
8-29	5932-170-6000-0	WASHER, SP Rondelle frein	4	4	22217-060000
8-30	5962-271-0100-2	STUD Goujon	1		26227-101002
8-30-1	5962-271-0105-2	STUD Goujon		1	26227-101052
8-31	5904-107-0798-0	NUT, EYE BOLT Ecrou	1		104107-07980
8-31-1	5904-407-0798-0	NUT, EYE BOLT Ecrou		1	104407-07980
8-32	5932-171-0000-0	WASHER, SP Rondelle frein	1	1	22217-100000
8-33	5931-371-0000-0	WASHER Rondelle	2	2	22137-100000
8-34	5966-171-0000-2	BOLT, EYE Boulon a oeil	1	1	26617-100002
8-35	5904-407-4462-0	BOLT Vis	7	10	104407-44620
8-36	5932-170-6000-0	WASHER, SP Rondelle frein	7	10	22217-060000
8-37	5965-570-6014-2	SCREW/M6 X 14 Vis	6	6	26557-060142
8-38	5931-370-4000-0	WASHER Rondelle	6	6	22137-040000
8-39	5965-870-6020-2	SCREW/M6 X 20 Vis	4	4	26587-060202
8-40	5932-170-6000-0	WASHER, SP Rondelle frein	4	4	22217-060000
8-41	5931-370-6000-0	WASHER Rondelle	4	4	22137-060000

Fig.9 COOLING FAN DRIVING DEVICE
Ventilateur

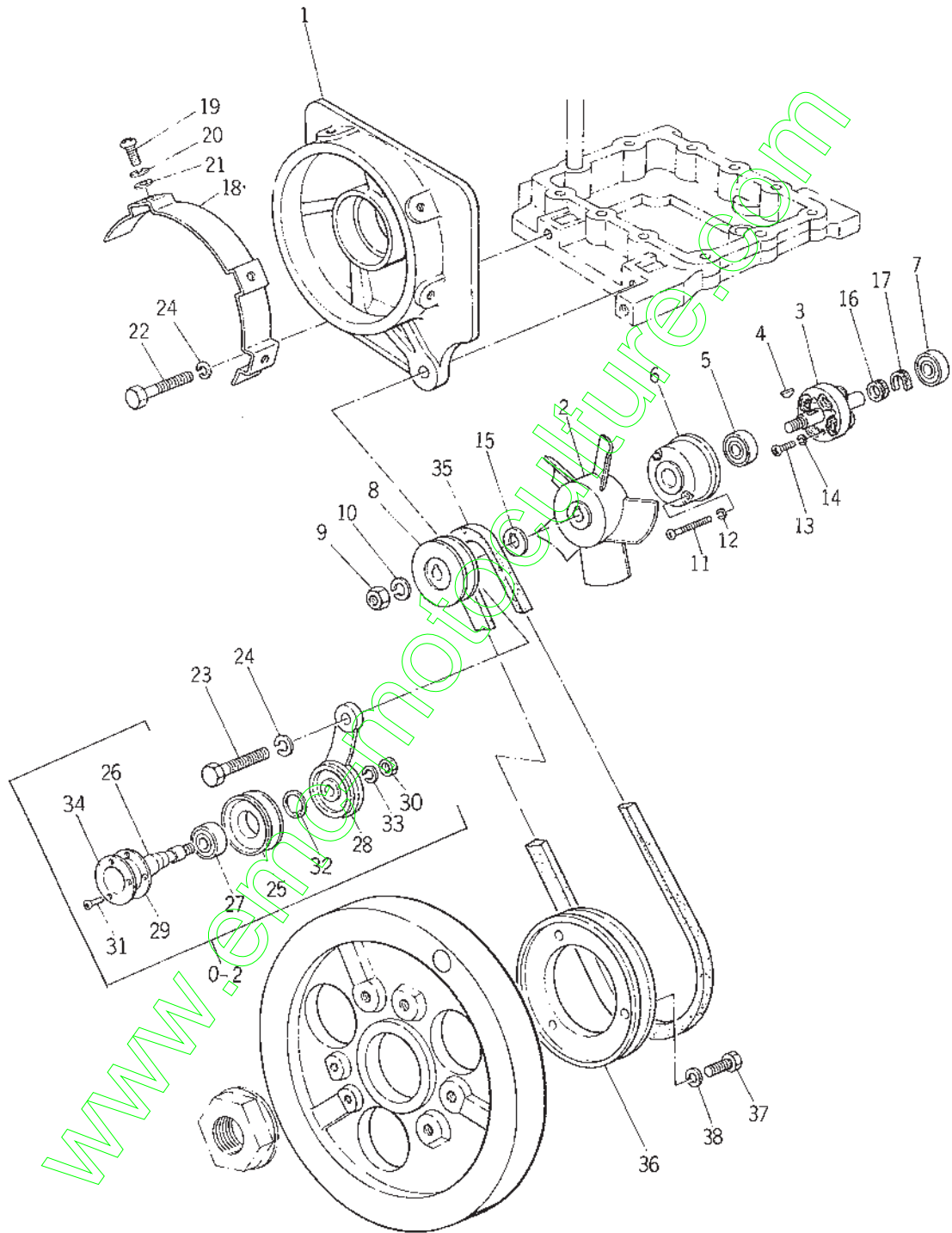

Ref.No. Réf.Nº	Parts No. Pièces Nº	Description Désignation	Model & Q'ty Modél & Quant		Remarks Remarques
			KS650	KA700	
9- 0-1	5984-108-4456-0	CASE, FAN ASSY Boîtier de ventilateur	1		704108-44560
9- 0-1-1	5984-408-4456-0	CASE, FAN ASSY Boîtier de ventilateur		1	704408-44560
9- 1		• CASE, COOLING FAN Boîtier de ventilateur	1	1	△
9- 2	5904-207-4470-0	• FAN, COOLING Pale de ventilateur	1		104207-44700
9- 2-1	5904-407-4470-0	• FAN, COOLING Pale de ventilateur		1	104407-44700
9- 3	5904-408-7801-0	• DYNAMO Génératrice	1	1	104408-78010
9- 4	5904-407-4479-0	• KEY Clavette	1	1	104407-44790
9- 5	5904-407-4472-0	• BEARING, BALL Roulement radial	1	1	104407-44720
9- 6	5904-407-4474-0	• CASE, BEARING Support de palier	1	1	104407-44740
9- 7	5904-407-4473-0	• BEARING, BALL Roulement radial	1	1	104407-44730
9- 8	5904-407-4477-0	• PULLEY, FAN Poulie	1	1	104407-44770
9- 9	5967-771-2000-2	• NUT/M12 Ecrou	1	1	26777-120002
9-10	5932-171-2000-0	• WASHER, SP/M12 Rondelle frein	1	1	22217-120000
9-11	5965-570-6055-2	• SCREW/M6 X 55 Vis	2	2	26557-060552
9-12	5932-170-6000-0	• WASHER, SP Rondelle frein	2	2	22217-060000
9-13	5965-570-4040-2	• SCREW/M4 X 40 Vis	2	2	26557-040402
9-14	5932-170-4000-0	• WASHER, SP Rondelle frein	2	2	22217-040000
9-15	5904-407-4476-0	• WASHER Rondelle	1	1	104407-44760
9-16	5901-374-7830-5	• BUSH/RUBBER Siège d'embout	1	1	101374-78305
9-17	5901-374-4475-5	• GUM, WIRE GUARDING Protecteur	1	1	101374-44755
9-18	5904-407-4469-0	DUCT, FAN UP Tunnel de ventilateur		1	104407-44690
9-19	5965-570-6012-2	SCREW/M6 X 12 Vis		3	26557-060122
9-20	5932-170-6000-0	WASHER, SP Rondelle frein		3	22217-060000
9-21	5931-370-6000-0	WASHER Rondelle		3	22137-060000
9-22	5961-171-0035-2	BOLT/M10 X 35 Vis	1	1	26117-100352
9-23	5961-171-0040-2	BOLT/M10 X 40 Vis	1		26117-100402
9-23-1	5961-171-0045-2	BOLT/M10 X 45 Vis		1	26117-100452
9-24	5932-171-0000-0	WASHER, SP/ Rondelle frein	2	2	22217-100000
9- 0-2	5904-407-4480-0	PULLEY, TENSION ASSY Gaiet tendeur	1	1	104407-44800
9-25	5903-388-4465-0	• PULLEY, TENSION Gaiet tendeur	1	1	103388-44650
9-26	5903-854-4490-0	• SHAFT, TENSION PULLEY Axe de tendeur	1	1	103854-44900
9-27	5951-020-6200-4	• BEARING, BALL Roulement radial	1	1	24102-062004
9-28	5903-388-4494-0	• LEVER, TENSION PULLEY Bras de tension	1	1	103388-44940
9-29	5901-374-4495-0	• PACKING, CAP Joint	1	1	101374-44950
9-30	5967-170-8000-2	• NUT/M8 Ecrou	1	1	26717-080002
9-31	5965-570-6006-2	• SCREW/M4 X 6 Vis	3	3	26557-060062
9-32	5932-520-0030-0	• CIRCLIP Collet d'axe	1	1	22252-000300
9-33	5932-170-8000-0	• WASHER, SP Rondelle frein	1	1	22217-080000

Ref.No. Réf.Nº.	Parts No. Pièces Nº.	Description Désignation	Model & Q'ty Modél & Quant		Remarks Remarques
			KS650	KA700	
9-34	5901-374-4493-0	•COVER, TENSION PULLEY Couvercle	1	1	101374-44930
9-35	5904-107-4478-0	BELT, V/864 Courroie trapézoïdale	1		104107-44780
9-35-1	5904-307-4478-0	BELT, V/914 Courroie trapézoïdale		1	104307-44780
9-36	5904-407-2160-0	PULLEY, V Poulie	1	1	104407-21600
9-37	5961-170-6014-2	BOLT/M6 X 14 Vis	3	3	26117-060142
9-38	5932-170-6000-0	WASHER, SP Rondelle frein	3	3	22217-060000

www.emc-motoculture.com

Ref.No. Réf.Nº	Parts No. Pièces Nº	Description Désignation	Model & Q'ty Modél & Quant		Remarks Remarques
			KS650	KA700	
10- 1	5984-100-5170-0	PUMP, FUEL INJ ASSY Pompe d'injection	1		704100-51700
10- 1-1	5984-300-5170-0	PUMP, FUEL INJ ASSY Pompe d'injection		1	704300-51700
10- 2	5901-158-5101-0	* BODY, FUEL INJ PUMP Corps	1	1	101158-51010
10- 3	5901-104-5110-0	* PLUNGER W/BARREL Piston	1		101104-51100
10- 3-1	5901-204-5110-0	* PLUNGER W/BARREL Piston		1	101204-51100
10- 4	5901-400-5116-0	* SPRING, PLUNGER Ressort	1	1	101400-51160
10- 5	5972-100-5117-0	* WASHER Rondelle	1		172100-51170
10- 5-1	5901-204-5117-0	* WASHER Rondelle		1	101204-51170
10- 6	5972-100-5119-0	* PACKING, BARREL Joint	1	1	172100-51190
10- 7	5902-100-5115-0	* SCREW, PLUNGER BARREL Vis	1	1	102100-51150
10- 8	5972-100-5129-0	* PACKING Joint	1	1	172100-51290
10- 0-1	5901-300-5130-0	* VALVE, DEL ASSY Soupape d'injecteur	1	1	101300-51300
10- 9		** VALVE, DEL Soupape d'injecteur	1	1	△
10-10		** SEAT, DEL VALVE Siege	1	1	△
10-11	5901-300-5133-0	** SPRING, DEL VALVE Ressort	1	1	101300-51330
10-12	5972-100-5134-0	* HOLDER, DEL VALVE Griffe	1	1	172100-51340
10- 0-2	5984-200-5155-0	* REGULATOR ASSY Limiteur de dosage	1	1	704200-51550
10-13		** BODY, REGULATOR Corps	1	1	△
10-14	5974-100-5144-0	** PACKING Joint	1	1	174100-51440
10-15	5904-200-5145-0	** SPACER, REGULATOR Rondelle de tarage	1	1	104200-51450
10-16	5904-200-5146-0	** O-RING, REGULATOR Joint torique	1	1	104200-51460
10-17	5971-590-5142-0	* VALVE, REGULATOR Soupape	1	1	171590-51420
10-18	5971-590-5143-0	* SPRING, REGULATOR Ressort	1	1	171590-51430
10-19	5904-200-5408-0	BOLT, PUMP BODY Vis	2	2	104200-54080
10-20	5901-158-5103-0	PACKING, PUMP BODY Joint	1	1	101158-51030
10-21	5901-104-6630-0	CAP, DUST Capuchon	1	1	101104-66300

Fig.11 FUEL INJECTION VALVE

Injecteur-pompe

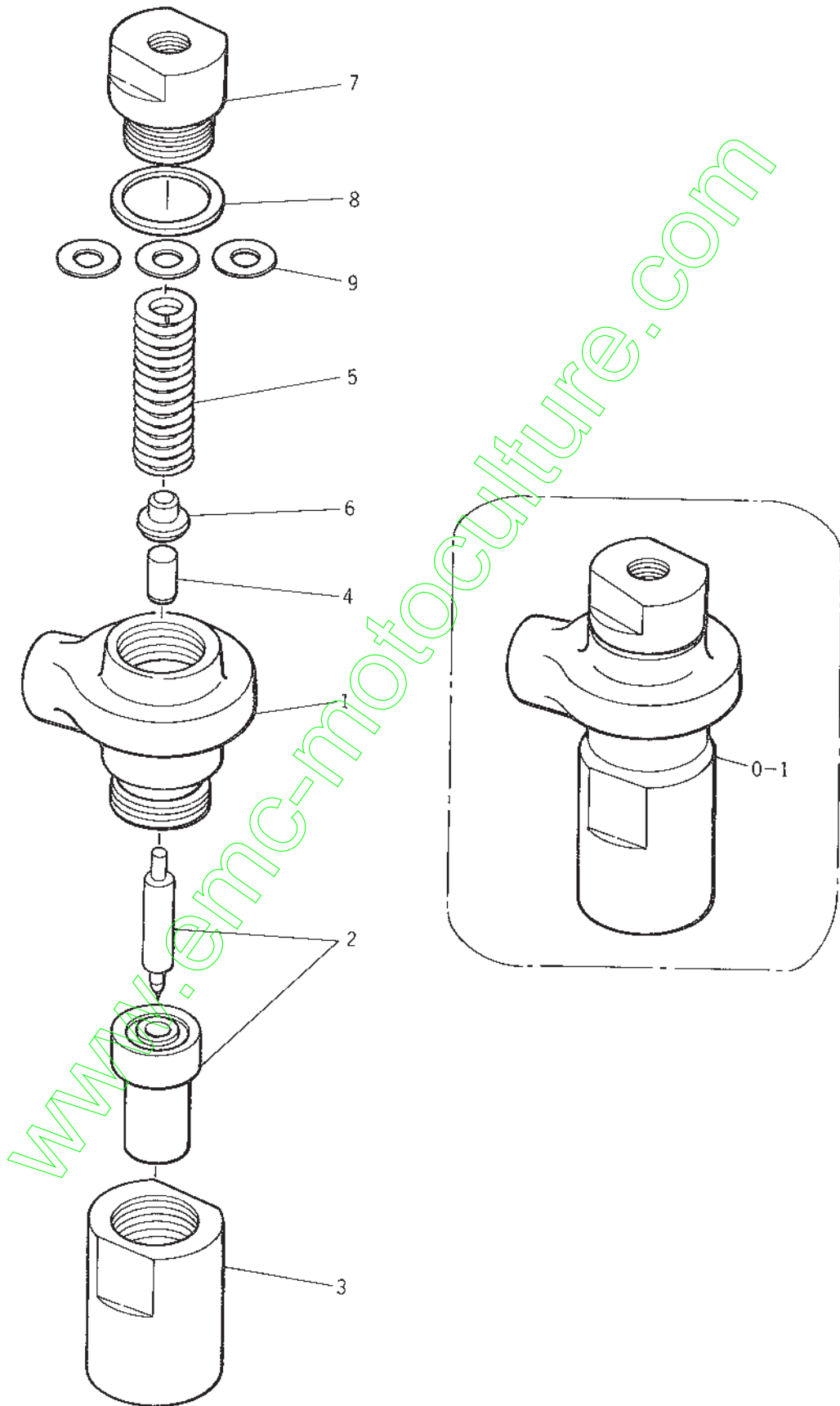

Ref.No. Réf.Nº	Parts No. Pièces Nº	Description Désignation	Model & Q'ty Modél & Quant		Remarks Remarques
			KS650	KA700	
11- 0-1	5984-100-5310-0	VALVE, FUEL INJ ASSY injecteur-pompe	1		704100-53100
11- 0-1-1	5984-300-5310-0	VALVE, FUEL INJ ASSY injecteur-pompe		1	704300-53100
11- 1	5903-854-5310-0	• BODY, FUEL INJ ASSY Corps	1	1	103854-53100
11- 2	5972-100-5300-0	• VALVE W/CASE Aiguille d'injecteur	1	1	172100-53000
11- 3	5981-147-5308-0	• HOLDER, INJ VALVE Porte injecteur	1		101147-53080
11- 3-1	5904-300-5308-0	• HOLDER, INJ VALVE Porte injecteur		1	104300-53080
11- 4	5813-200-5311-0	• SPINDLE Axe	1	1	113200-53110
11- 5	5903-854-5312-0	• SPRING, VALVE Ressort	1	1	103854-53120
11- 6	5813-200-5312-0	• HOLDER, VALVE SPRING Cuvette	1	1	113200-53120
11- 7	5903-854-5318-0	• CASE, VALVE SPRING Carter	1	1	103854-53180
11- 8	5972-100-5320-0	• PACKING, SPRING CASE Joint	1	1	172100-53200
11- 9	5810-250-5315-0	• SHIM SET Rondelle de tarage	1	1	110250-53150

Fig.12 FUEL OIL SYSTEM

Reservoir de combustible

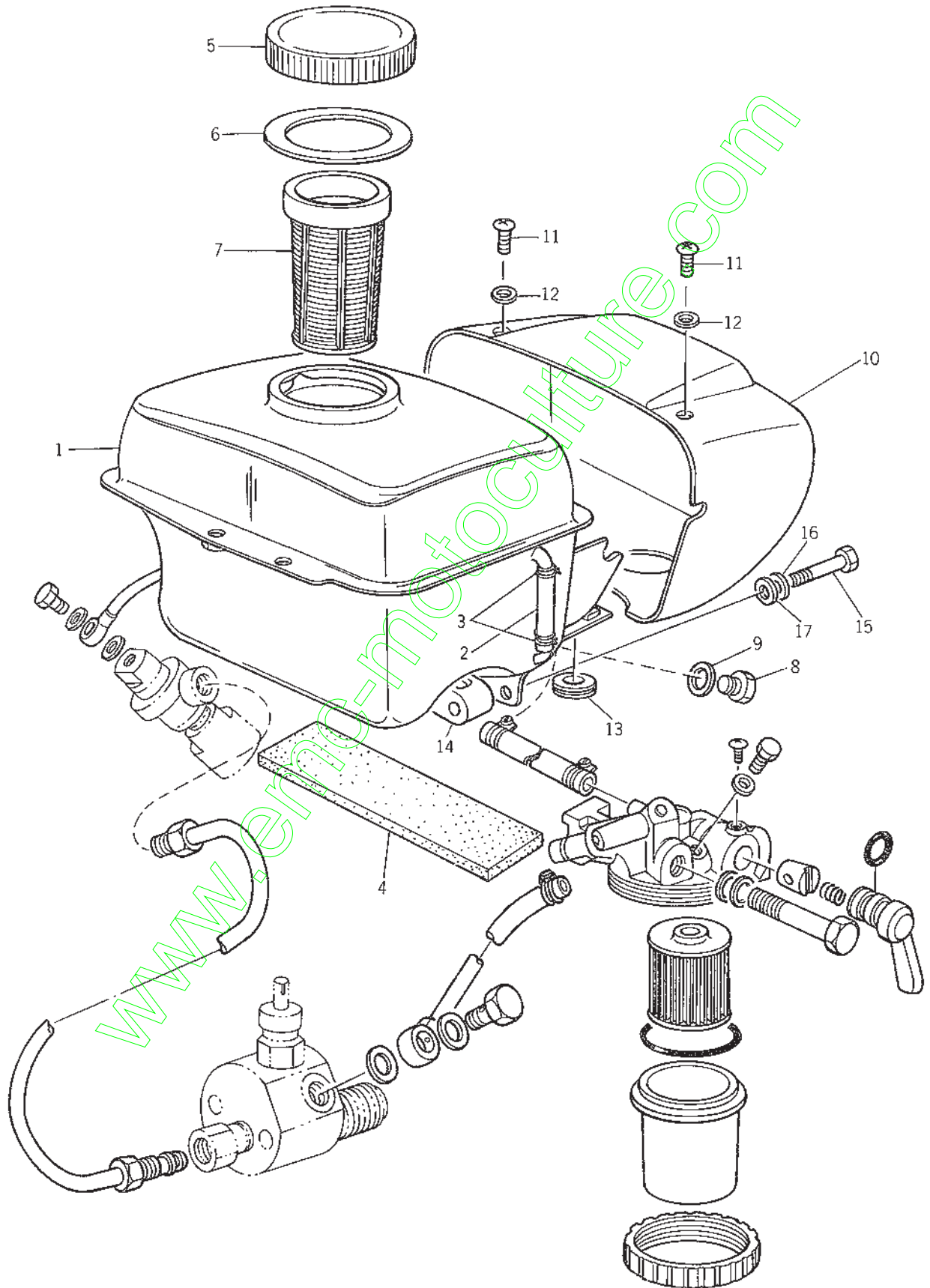

Ref.No. Réf.Nº.	Parts No. Pièces Nº.	Description Désignation	Model & Q'ty Modél & Quant		Remarks Remarques
			KS650	KA700	
12- 0-1	5984-108-5570-0	TANK, FUEL ASSY Réservoir de combustible	1		704108-55700
12- 0-1-1	5984-308-5570-0	TANK, FUEL ASSY Réservoir de combustible		1	704308-55700
12- 1		• TANK, FUEL Réservoir de combustible	1	1	△
12- 2	5904-700-5516-0	• GAUGE, LEVEL Jauge	1	1	104700-55160
12- 3	5903-854-5522-0	• CLAMP Collier	2	2	103854-55220
12- 4	5904-200-5520-0	• FELT, FUEL TANK Plaque d'appui de réservoir	1	1	104200-55200
12- 4-1	5904-507-5521-0	• FELT, FUEL TANK Plaque d'appui de réservoir	1		104507-55210
12- 4-1-1	5904-307-5520-0	• FELT, FUEL TANK Plaque d'appui de réservoir		1	104307-55200
12- 5	5901-168-5504-0	• COVER, INTAKE PORT Couvercle	1	1	101168-55040
12- 6	5901-504-5505-0	•• PACKING, COVER Joint	1	1	101504-55050
12- 7	5901-504-5510-1	• STRAINER, INTAKE PORT Filtre à combustible	1	1	101504-55101
12- 8	5904-200-5508-0	• PLUG, DRAIN Bouchon de vidange	1	1	104200-55080
12- 9	5944-141-2000-0	• PACKING, DRAIN PLUG Joint	1	1	23414-120000
12-10	5904-104-5581-0	COVER, LIGHT Couvercle	1		104104-55810
12-10-1	5904-304-5581-0	COVER, LIGHT Couvercle		1	104304-55810
12-11	5903-884-5532-0	SCREW Vis	4	4	103884-55320
12-12	5931-370-6000-0	WASHER Rondelle	4	4	22137-060000
12-13	5901-204-5582-0	GROMMET Bague de passage	1	1	101204-55820
12-14	5904-100-5524-0	MOUNT, FUEL TANK Plaque de fixation	1		104100-55240
12-14-1	5904-300-5524-0	MOUNT, FUEL TANK Plaque de fixation		1	104300-55240
12-15	5961-160-8040-2	BOLT/M8 X 40 Vis	2		26116-080402
12-15-1	5961-160-8045-2	BOLT/M8 X 45 Vis		2	26116-080452
12-16	5932-170-8000-0	WASHER, SP Rondelle frein	2	2	22217-080000
12-17	5931-370-8000-0	WASHER Rondelle	2	2	22137-080000

Fig.13 FUEL STRAINER

Filtre a combustible

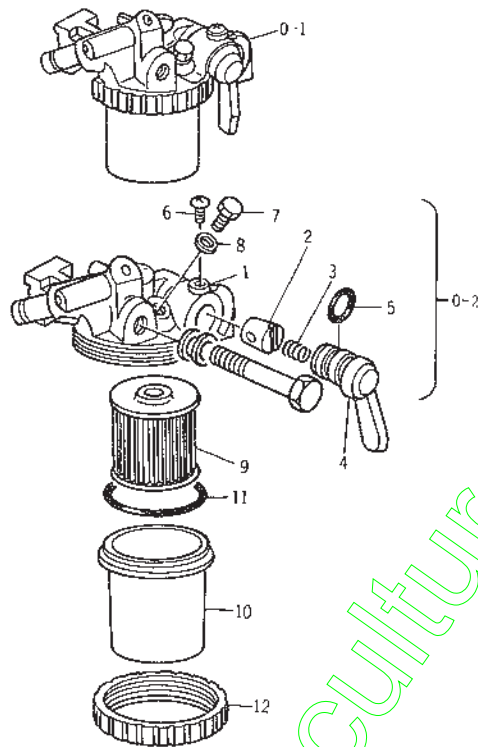

Ref.No. Réf.Nº.	Parts No. Pièces N°.	Description Désignation	Model & Q'ty Modél & Quant		Remarks Remarques
			KS650	KA700	
13- 0-1	5984-300-5550-0	STRAINER, FUEL ASSY Filtre a combustible	1	1	704300-55500
13- 0-2	5984-200-5520-0	• COCK, FUEL ASSY Robinnet	1	1	704200-55200
13- 1		• BODY, FUEL COCK Corps de filtre	1	1	△
13- 2		• VALVE, TAPER Soupape	1	1	△
13- 3	5904-200-5533-0	• SPRING, TAPER VALVE Ressort	1	1	104200-55330
13- 4	5904-200-5534-0	• HANDLE, COCK Lévier	1	1	104200-55340
13- 5	5953-112-4010-0	• O-RING Joint torique	1	1	24311-240100
13- 6	5904-200-5575-0	• SCREW/M4 X 10.4 Vis	1	1	104200-55750
13- 7	5901-720-5575-0	• PLUG, BREATHER Bouchon	1	1	101720-55750
13- 8	5944-180-6000-0	• PACKING, PLUG Joint	1	1	23418-060000
13- 9	5904-200-5571-0	• ELEMENT, STRAINER Element	1	1	104200-55710
13-10	5902-103-5551-0	• BOWL Cuve	1	1	102103-55510
13-11	5902-103-5552-0	• O-RING Joint torique	1	1	102103-55520
13-12	5810-250-5561-0	• RETAINER Ecras de cuve	1	1	110250-55610

Fig.14 FUEL PIPE
Conduit de combustible

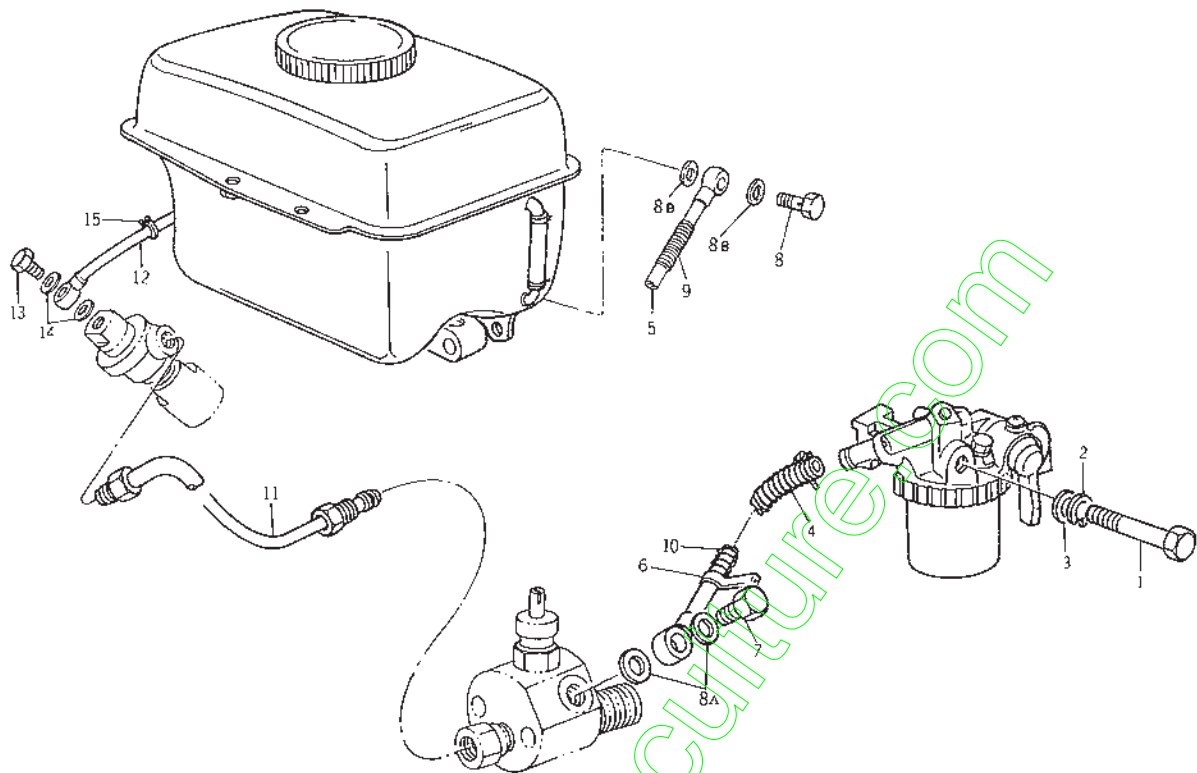

Ref.No. Réf.Nº	Parts No. Pièces Nº	Description Désignation	Model & Q'ty Modél & Quant		Remarks Remarques
			KS650	KA700	
14- 1	5961-170-8060-2	BOLT/M8 X 60 Vis	1	1	26117-080602
14- 2	5932-170-8000-0	WASHER, SP Rondelle frein	1	1	22217-080000
14- 3	5931-370-8000-0	WASHER Rondelle	1	1	22137-080000
14- 4	5904-700-5901-0	PIPE, FUEL A Conduit de combustible	1	1	104700-59010
14- 5	5904-300-5903-0	PIPE, FUEL B Conduit de combustible	1	1	104300-59030
14- 6	5904-100-1200-0	CLAMP Collier	1	1	23010-012000
14- 7	5904-100-5992-0	FITTING, FUEL PIPE Raccord	1	1	104100-59920
14- 8	5903-854-3914-0	JOINT, FUEL PIPE Raccord	2	2	103854-39140
14- 8A	5904-200-5917-0	PACKING Joint	2	2	104200-59170
14- 8B	5944-141-2000-0	PACKING Joint	2	2	23414-120000
14- 9	5904-200-5940-0	SPRING, PIPE SHELTER Ressort	1	1	104200-59400
14-10	5904-700-5906-0	SPRING, PIPE SHELTER Ressort	1	1	104700-59060
14-11	5904-100-5980-0	PIPE, FUEL INJ Conduit haute pression	1		104100-59800
14-11-1	5904-300-5980-0	PIPE, FUEL INJ Conduit haute pression		1	104300-59800
14-12	5903-854-5914-1	PIPE, FUEL OVERFLOW Conduit de trop-plein	1	1	103854-59141
14-13	5901-147-5981-0	BOLT, PIPE JOINT Raccord	1	1	101147-59810
14-14	5944-140-8000-0	PACKING Joint	2	2	23414-080000
14-15	5904-200-5941-0	CLAMP, OVER FLOW PIPE Collier	1	1	104200-59410

Fig.15 GOVERNOR DEVICE
Regulateur

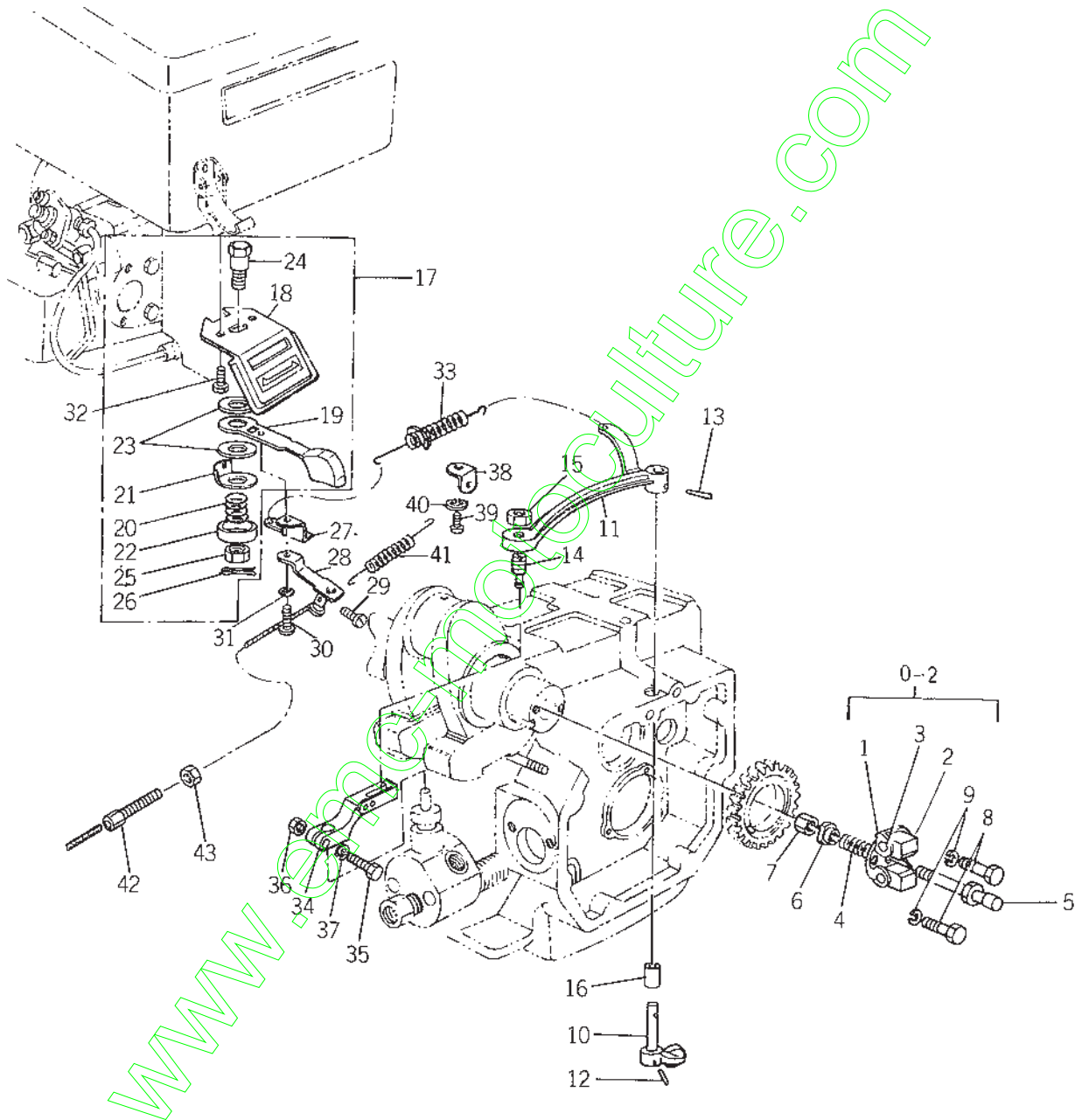

Ref.No. Réf.Nº.	Parts No. Pièces Nº.	Description Désignation	Model & Q'ty Modél & Quant		Remarks Remarques
			KS650	KA700	
15- 0-1	5986-100-6170-0	GOVERNOR ASSY Regulateur	1		706100-61700
15- 0-1-1	5981-104-6110-0	GOVERNOR ASSY Regulateur		1	701104-61100
15- 0-2	5981-104-6152-0	WEIGHT, GOVERNOR ASSY Masselotte		1	701104-61520
15- 1		SUPPORT, WEIGHT Support		1	Order assy
15- 2		WEIGHT, GOVERNOR Masselotte		2	Order assy
15- 3		PIN, GOVERNOR WEIGHT Goupille		2	Order assy
15- 4	5904-211-6136-0	SPRING, GOVERNOR Ressort	1		104211-61360
15- 4-1	5901-104-6136-0	SPRING, GOVERNOR Ressort		1	101104-61360
15- 5	5904-211-6130-0	SPINDLE, GOVERNOR Guidage d'entraineur	1		104211-61300
15- 5-1	5901-104-6130-0	SPINDLE, GOVERNOR Guidage d'entraineur		1	101104-61300
15- 6	5904-211-6134-0	SUPPORT, SPRING Coulisseau	1		104211-61340
15- 6-1	5901-104-6134-1	SUPPORT, SPRING Coulisseau		1	101104-61341
15- 7	5967-570-6000-2	NUT, GOVERNOR SPINDLE Erou	1	1	26757-060002
15- 8	5964-500-6018-2	BOLT, SUPPORT Vis	2		26450-060182
15- 8-1	5974-100-6160-0	BOLT, SUPPORT Vis		2	174100-61600
15- 9	5932-170-6000-0	WASHER, SP Rondelle frein	2	2	22217-060000
15- 0-3	5986-100-6150-0	LEVER, GOVERNOR ASSY Lever	1		706100-61500
15- 0-3-1	5986-300-6150-0	LEVER, GOVERNOR ASSY Lever		1	706300-61500
15-10		LEVER/1ST Lever		1	△
15-11		LEVER/2ND Lever		1	△
15-12	5933-220-3016-0	PIN, TAPER/3 X 16 Goupille	1	1	22322-030160
15-13	5933-220-3024-0	PIN, TAPER/3 X 24 Goupille	1	1	22322-030240
15-14	5904-100-6636-0	SCREW Vis	1	1	104100-66360
15-15	5967-771-0000-2	NUT/M10 Erou	1	1	26777-100002
15-16	5906-100-6152-0	BUSH, GOVERNOR LEVER Douille	1		106100-61520
15-16-1	5904-100-6152-0	BUSH, GOVERNOR LEVER Douille		1	104100-61520
15-17	5984-104-6650-0	MOUNT, HANDLE ASSY Plaque de fixation	1	1	704104-66500
15-18		MOUNT, HANDLE Plaque de fixation	1	1	△
15-19	5904-200-6605-0	HANDLE, REGULATOR Poignée	1	1	104200-66050
15-20	5904-200-6682-0	SPRING Ressort	1	1	104200-66820
15-21	5904-200-6684-0	WASHER A Rondelle	1	1	104200-66840
15-22	5904-200-6685-0	WASHER B Rondelle	1	1	104200-66850
15-23	5904-200-6683-0	PLATE, FRICTION Plaque de frein	2	2	104200-66830
15-24	5904-200-6687-0	BOLT Vis	1	1	104200-66870
15-25	5904-200-6686-0	NUT Erou	1	1	104200-66860
15-26	5934-111-0015-0	PIN, SPLIT Goupille fendue	1	1	22411-100150
15-27	5904-104-6659-0	FITTING, SPRING Griffe de ressort	1	1	104104-66590
15-28	5904-104-6696-0	FITTING, IN WIRE ASSY Griffe de cable	1	1	104104-66960

Ref.No. Réf.N°	Parts No. Pièces N°	Description Désignation	Model & Q'ty Modél & Quant		Remarks Remarques
			KS650	KA700	
15-29	5904-104-6699-0	• SCREW Vis	1	1	104104-66990
15-30	5965-570-4008-2	SCREW/M4 X 8 Vis	1	1	26557-040082
15-31	5932-170-4000-0	WASHER, SP Rondelle frein	1	1	22217-040000
15-32	5961-170-6012-9	BOLT/M6 X 12 Vis	2	2	26117-060129
15-33	5906-130-6609-0	SPRING, REGULATOR Ressort	1		106130-66090
15-33-1	5904-300-6609-0	SPRING, REGULATOR Ressort		1	104300-66090
15-34	5904-200-6623-0	LEVER, INJ PUMP ADJ Lever de réglage	1	1	104200-66230
15-35	5974-100-3459-1	BOLT, ADJ LEVER Vis	1	1	174100-34591
15-36	5967-771-0000-2	NUT Erou	1	1	26777-100002
15-37	5932-170-6000-0	WASHER, SP Rondelle frein	1	1	22217-060000
15-38	5904-104-6733-0	SUPPORT, SPRING Griffe de ressort	1	1	104104-67330
15-39	5965-570-6012-2	SCREW/M6 X 12 Vis	1	1	26557-060122
15-40	5932-170-6000-0	WASHER, SP Rondelle frein	1	1	22217-060000
15-41	5904-104-6730-0	SPRING, RETURN Ressort de rappel	1	1	104104-67300
15-42	5902-100-6708-0	BOLT, ADJ Vis de butée	1	1	102100-67080
15-43	5967-570-6000-2	NUT/M6 Erou	1	1	26757-060002

Fig.16 STARTING DEVICE

Manivelle de lancement

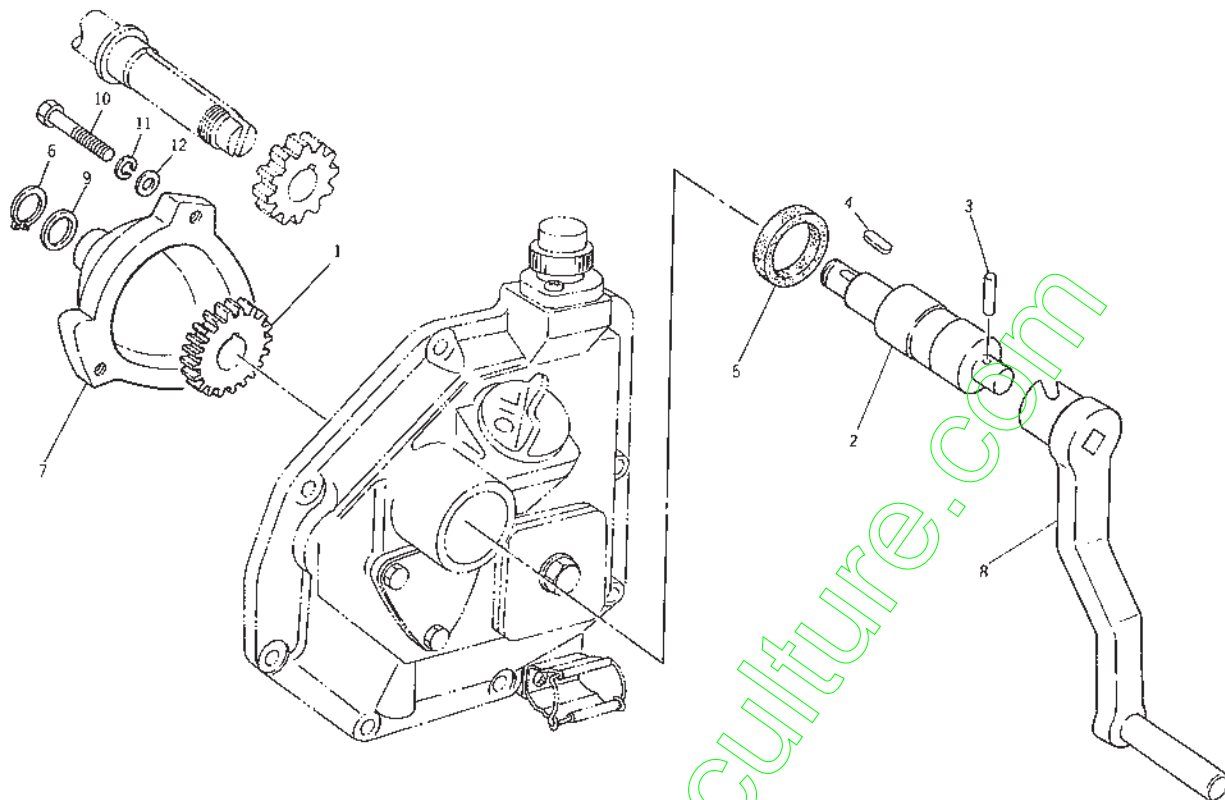

Ref.No. Réf.Nº.	Parts No. Pièces Nº.	Description Désignation	Model & Q'ty Modél & Quant		Remarks Remarques
			KS650	KA700	
16- 1	5904-200-7633-0	GEAR, STARTING Pignon	1		104200-76330
16- 1-1	5904-300-7633-0	GEAR, STARTING Pignon		1	104300-76330
16- 2	5986-100-7690-0	SHAFT, STARTING ASSY Axe	1	1	706100-76900
16- 3	5904-200-7648-0	*PIN, STARTING SHAFT/7 X 31 Goupille	1	1	104200-76480
16- 4	5901-400-7649-0	KEY, STARTING GEAR Clavette	1	1	101400-76490
16- 5	5904-200-7650-0	SEAL, OIL Bague d'étanchéité	1	1	104200-76500
16- 6	5932-420-0014-0	CIRCLIP Collet d'axe	1	1	22242-000140
16- 7	5904-100-7630-0	MOUNT, STARTING DEVICE Corps	1		104100-76300
16- 7-1	5904-300-7630-0	MOUNT, STARTING DEVICE Corps		1	104300-76300
16- 8	5906-100-7679-0	HANDLE, STARTING Manivelle de lancement	1	1	106100-76790
16- 9	5972-200-1127-1	WASHER Rondelle	1	1	172200-11271
16-10	5961-170-6038-2	BOLT/M6 X 38 Vis	3	3	26117-060382
16-11	5932-170-6000-0	WASHER, SP Rondelle frein	3	3	22217-060000
16-12	5931-370-6000-0	WASHER Rondelle	3	3	22137-060000

Fig.17 LIGHTING DEVICE
 Equipment électrique

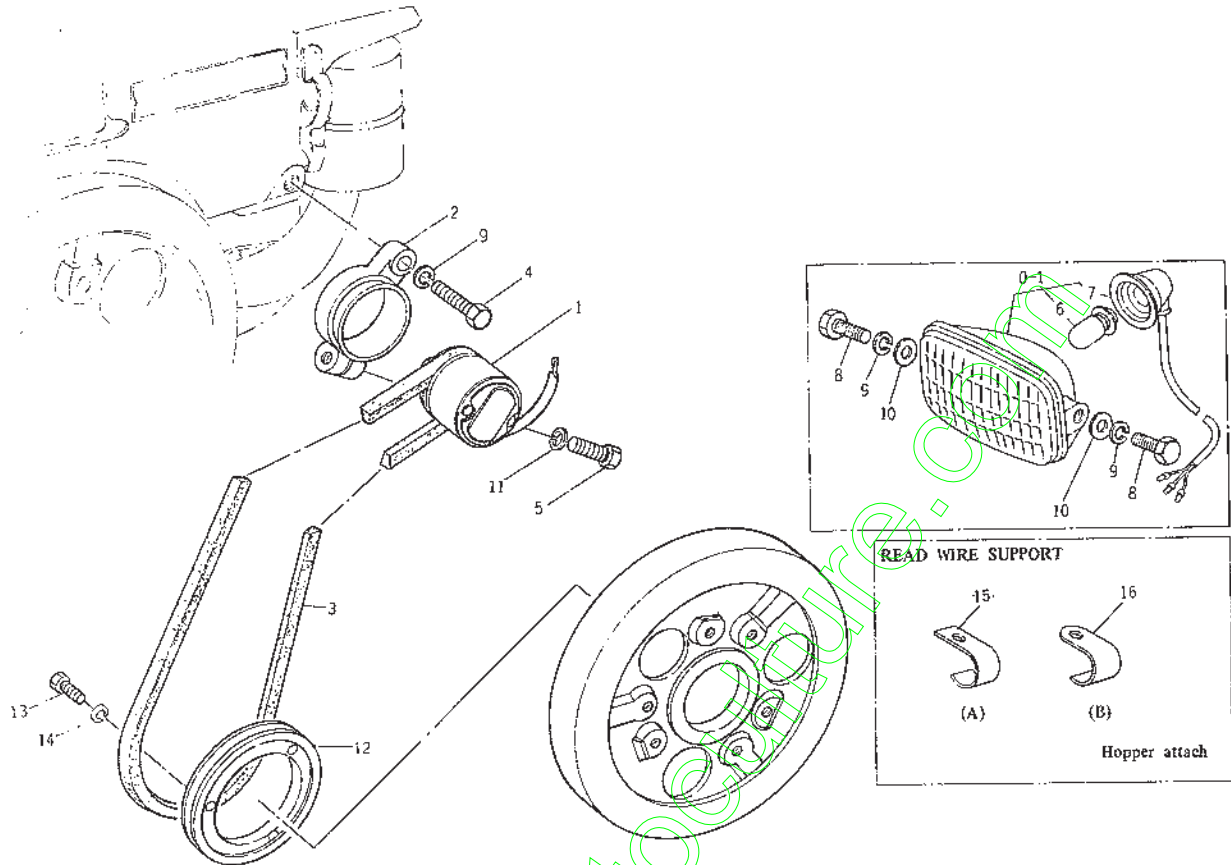

Ref.No. Réf.Nº	Parts No. Pièces Nº	Description Désignation	Model & Q'ty Modél & Quant		Remarks Remarques
			KS650	KA700	
17- 1	5904-408-7801-0	GENERATOR, LIGHTING Génératrice	1	1	104408-78010
17- 2	5904-104-7829-0	SUPPORT, GENERATOR Support	1	1	104104-78290
17- 3	5904-104-7878-0	BELT, V Courroie trapézoïdale	1		104104-78780
17- 3-1	5904-304-7878-0	BELT, V Courroie trapézoïdale		1	104304-78780
17- 4	5961-171-0038-2	BOLT/M10 X 38 Vis	1	1	26117-100382
17- 5	5961-170-8030-2	BOLT/M8 X 30 Vis	1	1	26117-080302
17- 0-1	5906-330-7802-0	LAMP, HEAD ASSY Projecteur principal	1	1	106330-78020
17- 6	5906-130-7825-0	BULB Ampoule de lampe	1	1	106130-78250
17- 7	5906-330-7804-0	SOCKET Connecteur	1	1	106330-78040
17- 8	5961-171-0016-2	BOLT/M10 X 16 Vis	2	2	26117-100162
17- 9	5932-171-0000-0	WASHER, SP Rondelle frein	2	2	22217-100000
17-10	5931-371-0000-0	WASHER Rondelle	2	2	22137-100000
17-11	5932-170-8000-0	WASHER, SP Rondelle frein	1	1	22217-080000
17-12	5904-104-2160-0	PULLEY, V Poulie	1	1	104104-21600
17-13	5961-140-6014-2	BOLT/M6 X 4 Vis	3	3	26114-060142
17-14	5932-170-6000-0	WASHER Rondelle	3	3	22217-060000
17-15	5904-104-7880-1	SUPPORT A, LEAD WIRE Collier	1	1	104104-78801
17-16	5904-104-7881-0	SUPPORT A, LEAD WIRE Collier	1	1	104104-78810

Fig.18 TOOLS
Outils

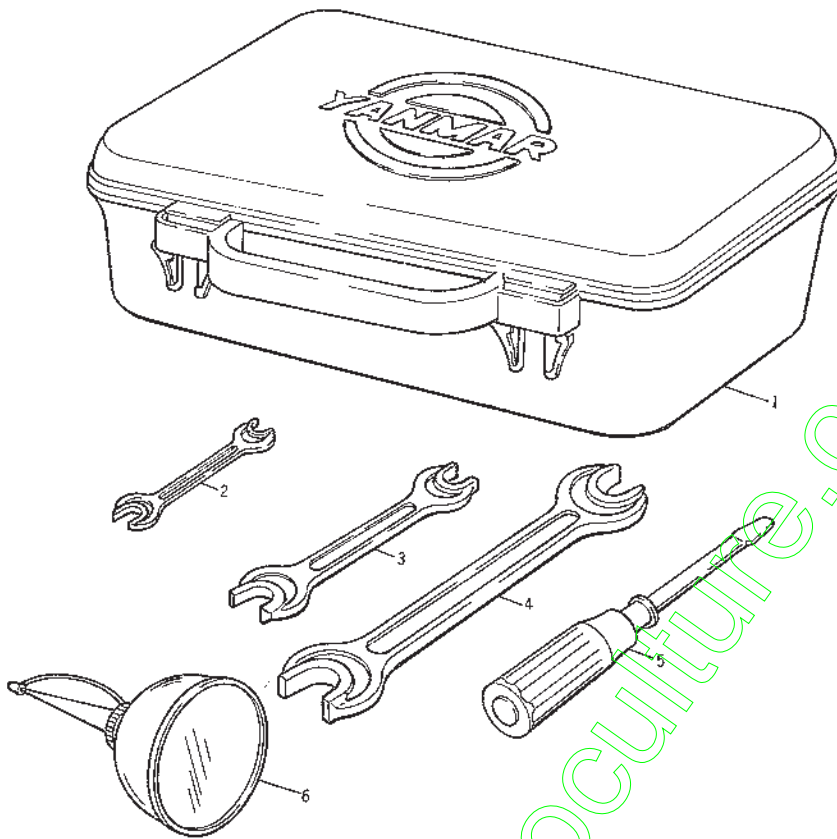

Ref.No. Réf.Nº	Parts No. Pièces Nº	Description Désignation	Model & Q'ty Modél & Quant		Remarks Remarques
			KS650	KA700	
18- 0-1	5984-507-9210-0	TOOL ASSY Trousse d'outillage	1	1	704507-92100
18- 1	5904-200-9260-0	• BOX, TOOL Trousse d'outillage	1	1	104200-92600
18- 2	5881-101-0013-0	• SPANNER/10 X 13 Cle plate double	1	1	28110-100130
18- 3	5881-101-7019-0	• SPANNER/17 X 19 Cle plate double	1	1	28110-170190
18- 4	5881-102-2024-0	• SPANNER/22 X 24 Cle plate double	1	1	28110-220240
18- 5	5904-200-9235-0	• SCREWDRIVER Tournevis	1	1	104200-92350
18- 6	5882-100-0015-0	• FEEDER, GASOLINE Burette	1	1	28210-000150



**Yvan Béal - 21, av. de l'Agriculture - B.P. 16
Z.I. du Brézet - 63014 Clermont-Ferrand Cedex 2
Tél : 04 73 91 93 51 - Télécopie : 04 73 90 23 11
www.yvanbeal.fr - E-mail : info@yvanbeal.fr
R.C.S. Clermont-Fd B 304 973 886 - S.A.S. au capital de 612 000 €**