

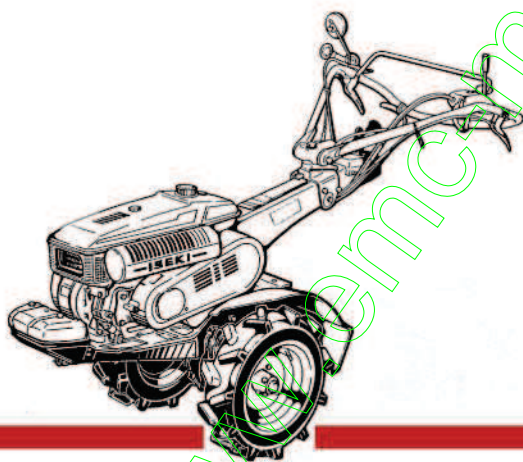

PIECES DETACHEES

Motoculteur



KS652 (ESSENCE)



Yvon Béal - 21, av. de l'Agriculture - B.P 16
Z.I. du Brézet - 63014 Clermont-Ferrand Cedex 2
Tél : 04 73 61 92 51 - Télécopie : 04 73 90 23 11
www.yvonbeal.fr - E-mail : info@yvonbeal.fr
R.C.S. B 304 973 800 - S.A.S. au capital de 612 000 €

03-000383-050429

HOW TO USE THIS PARTS CATALOGUE

CATALOGUE CONSTRUCTION

Ref. No.	Parts No.	Description	Q'ty	Remarks
A	B	C	D	E

- A. Ref. No. :** It is a reference number to find parts in the drawings.
- B. Parts No. :** Every part has its own 12-digit code number with which it is computer-controlled. Parts which have "V" at their code numbers' head are purchasable in the market.
- C. Description :** Names, sizes, functions and other meanings of parts are found in this column. "LH" and "RH" of parts are given by facing to the tractor-moving-forward direction or looking at them mounted on the tractor. Components of an assembled part (ASS'Y or SET) are listed set in from ASS'Y or SET name and headed with "." as in the following example:

(Example)

JOINT (A) ASS'Y

- YOKE (A), SPLINE
- JOINT, CROSS
- YOKE (B), SPLINE
- RING, SNAP/C TYPE 20



Abbreviations which are used in this column are explained in Table page 2.

- D. Q'ty :** This column specifies the quantity of a part required for one tractor. "AR" is the abbreviation of "AS REQUIRED".
- E. Remarks :** Additional notices are said here if any.

Explanation of symbols :

- ★ shows parts made to order.
- △ shows parts not sold as a single part.
- Ⓐ interchangeable with old and new type. (New ↔ Old)
- Ⓑ new type can be used on old type. (New → Old)
old type cannot be used on new type.
- Ⓒ not interchangeable. (New ✕ Old)
- Ⓓ abolished.
- Ⓔ newly included.

REQUESTS ON ORDERING PARTS :

Code No., Part Name, and Quantity should be typed clearly and correctly on your order sheet without fail.

Especially wrong code numbers which are computer-controlled may result in wrong delivery of parts.

ABBREVIATIONS

ABBREVIATIONS	ORIGINAL WORDS	ABBREVIATIONS	ORIGINAL WORDS
ACCEL	ACCELERATOR	NO	NUMBER
ADJ	ADJUST, ADJUSTING	NR	NEEDLE ROLLER
ASSY	ASSEMBLY	OS	OVER SIZE
BKT	BRACKET	P=	PITCH
CONN	CONNECTING	PKG	PACKING
CRANK	CRANKSHAFT	PL	PLAIN
CYL	CYLINDER	PRESS	PRESSURE
DEL	DELIVERY	PTO	POWER TAKE OFF
DIFF	DIFFERENTIAL	R	REAR
EXH	EXHAUST	RB	RADIAL BALL
F	FRONT	RH	RIGHT HAND
HI	HIGH	SP	SPRING
HYD	HYDRAULIC	ST	STRAIGHT
I	INNER	STD	STANDARD
INJ	INJECTION	T	TEETH
LH	LEFT HAND	TB	THRUST BALL
LW	LOWER	US	UNDER SIZE
MANF	MANIFOLD	UP	UPPER
MAX	MAXIMUM	W:	WITH
MECH	MECHANICAL	3P	THREE POINT
MIN	MINIMUM	W/O	WITHOUT

ENGINE
FG270G-AB01 (FG270G-4X, 315730A)

for KS652-HE40

www.emc-motoculture.com

www.emc-motoculture.com

CONTENTS

ENGINE

Fig. E-1	FG270G-AB01 (FG270G-4X, 315730A)	1
Fig. A-1	AIR CLEANER	6
Fig. C-1	CARBURETOR	7
Fig. F-1	FILTER	9
Fig. R-1	RECOIL STARTER	10

NOTE)

* Marked parts in the column remarks, are not always in stock, requiring considerable time for their delivery.

Fig. E-1 FG270G-AB01 (FG270G-4X, 315730A)

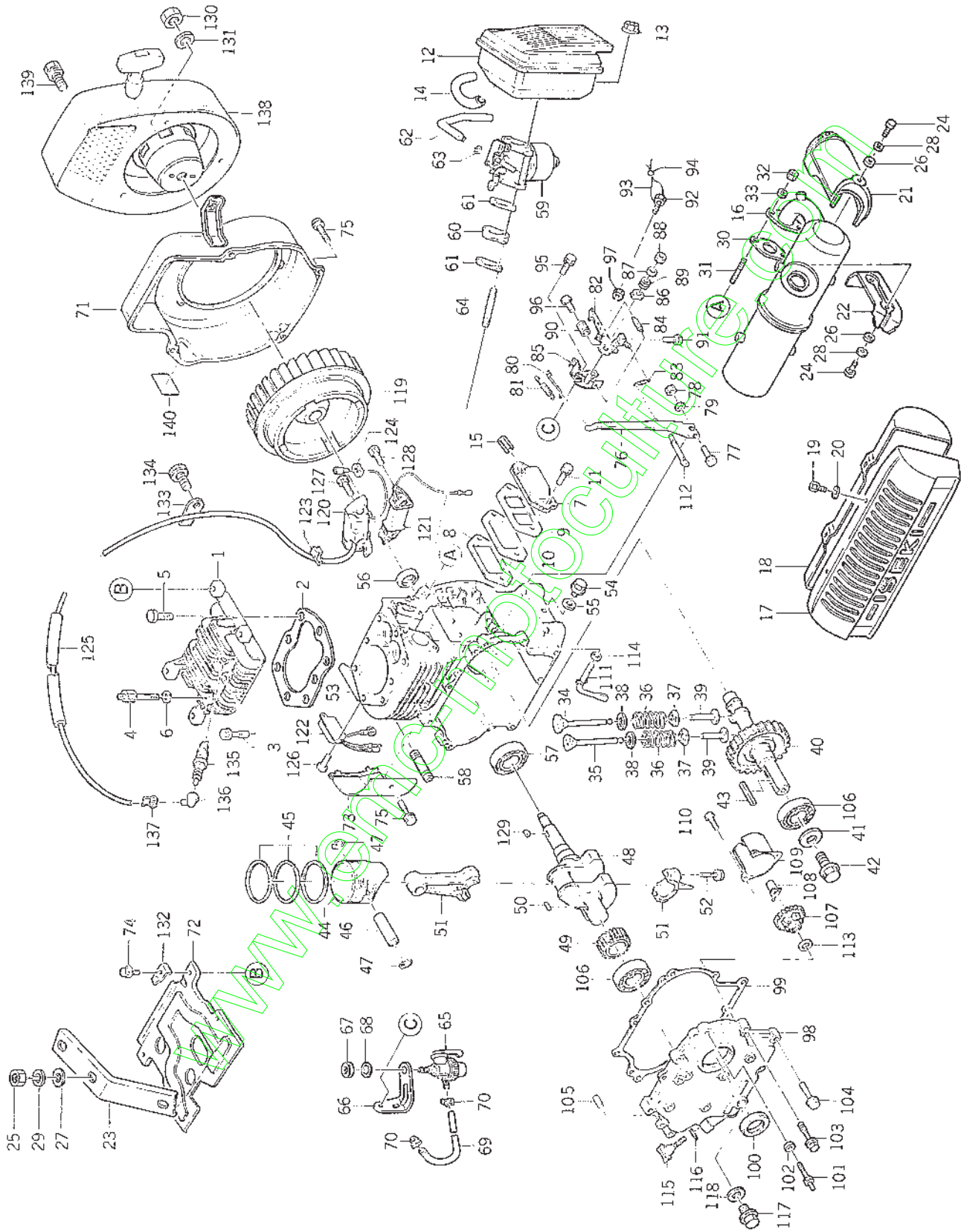

Ref. No.	Part No.	Description	Q'ty	Remarks	
1	5157-011-111-AX	HEAD, CLY.	1	315701-1111A	
2	5157-011-121-AX	GASKET, HEAD	1	315701-1121A	
3	5158-011-181-AX	BOLT, CLY. HEAD	3	315801-1181A	
4	5157-211-181-AX	BOLT, CLY. HEAD	2	315721-1181A	
5	5130-G10-45X-XX	BOLT/M10x45	3	130G1045	
6	5410-B10-00X-XX	WASHER, PL/M10	2	410B1000	
7	5158-011-231-AX	COVER, INSPECTION	1	315801-1231A	
8	5164-701-232-00	GASKET	1	316470-1232-00	
9	5158-011-233-AX	GASKET	1	315801-1233A	
10	5158-011-510-EX	BREATHER	1	315801-1510E	
11	5130-B06-12X-XX	BOLT/M6x12	2	130B0612	
12	5158-011-310-AX	AIR CLEANER ASSY	1	315801-1310A	See Fig. A-1
13	5158-011-388-AX	NUT	2	315801-1388A	
14	5157-211-531-AX	PIPE, BREATHER	1	315721-1531A	
15	5144-011-341-AX	PIPE	1	314401-1341A	
16	5157-211-400-AX	MUFFLER ASSY	1	315721-1400A	
17	5157-211-431-AX	•COVER, MUFFLER	1	315721-1431A	
18	5157-211-432-AX	•COVER, MUFFLER	1	315721-1432A	
19	5180-B06-12X-XX	•BOLT/M6x12	4	180B0612	
20	5411-B06-00X-XX	•WASHER, PL/M6	4	411B0600	
21	5157-211-433-AX	COVER, EXH.	1	315721-1433A	
22	5157-211-434-AX	COVER, EXH.	1	315721-1434A	
23	5157-211-445-AX	STAY, MUFFLER	1	315721-1445A	
24	5110-R06-10X-XX	BOLT/M6x10	4	110R0610	
25	5314-B10-00X-XX	NUT/M10	3	314B1000	
26	5411-B06-00X-XX	WASHER, PL/M6	4	411B0600	
27	5411-B10-00X-XX	WASHER, PL/M10	3	411B1000	
28	5461-F06-00A-XX	WASHER, SP/M6	4	461F0600A	
29	5461-F10-00A-XX	WASHER, SP/M10	3	461F1000A	
30	5164-701-442-00	GASKET	1	316470-1442-00	
31	5171-G08-18X-XX	STUD	2	171G0818	
32	5317-R08-00X-XX	NUT/M8	2	317R0800	
33	5461-F08-00X-XX	WASHER, SP/M8	2	461F0800	
34	5158-002-111-AX	VALVE, INLET	1	315800-2111A	
35	5158-012-112-AX	VALVE, EXH.	1	315801-2112A	
36	5158-012-113-AX	SPRING, VALVE	2	315801-2113A	
37	5158-012-116-AX	SEAT, SPRING	2	315801-2116A	
38	5158-012-121-AX	SEAT, SPRING	2	315801-2121A	
39	5158-012-211-AX	TAPPET	2	315801-2211A	

Ref. No.	Part No.	Description	Q'ty	Remarks	
40	5158-012-310-AX	CAM GEAR ASSY	1	315801-2310A	
41	5164-913-274-00	WASHER	1	316491-3274-00	
42	5183-B08-25X-XX	BOLT/M8x25	1	183B0825	
43	5511-A07-35X-XX	KEY	1	511A0735	
44	5157-013-111-AX	PISTON	1	315701-3111A	
45	5157-013-010-AX	PISTON RING SET	1	315701-3010A	
46	5158-013-121-AX	PIN, PISTON	1	315801-3121A	
47	5158-013-122-AX	RING, SNAP	2	315801-3122A	
48	5157-213-210-AX	CRANK SHAFT ASSY	1	315721-3210A	
49	5158-013-217-AX	•GEAR, CRANK	1	315801-3217A	
50	5136-502-371-00	•KEY	1	313650-2371-00	
51	5158-013-240-BX	CONN. ROD ASSY	1	315801-3240B	
52	5158-013-245-AX	•BOLT, CONN. ROD	2	315801-3245A	
53	5157-214-110-BX	CRANK CASE ASSY	1	315721-4110B	
54	5154-707-441-AX	•PLUG, DRAIN	2	315470-7441A	
55	5154-707-214-AX	•GASKET	2	315470-7214A	
56	5158-014-231-AX	SEAL, OIL	1	315801-4231A	
57	5601-A62-06X-XX	BEARING, RB/6206	1	601A6206	
58	5172-G08-100-XX	STUD	1	172G08100	
59	5157-216-100-AX	CARBURETOR ASSY	1	315721-6100A	See Fig. C-1
60	5158-016-181-AX	INSULATOR	1	315801-6181A	
61	5158-016-184-AX	GASKET	2	315801-6184A	
62	5158-226-852-AX	TUBE	1	315822-6852A	
63	5114-096-812-00	RING, SNAP	1	311409-6812-00	
64	5172-G06-85X-XX	STUD	2	172G0685	
65	5136-506-510-02	FILTER ASSY	1	313650-6510-02	See Fig. F-1
66	5156-216-561-CX	BRACKET	1	315621-6561C	
67	5136-506-527-00	NUT	1	313650-6527-00	
68	5463-H10-00X-XX	WASHER, TOOTH/M10	1	463H1000	
69	5702-A04-100-0X	TUBE, RUBBER/φ=210mm	1	702A041000	
70	5136-796-812-00	CLIP	2	313679-6812-00	
71	5157-211-611-AX	CASE, SPIRAL	1	315721-1611A	
72	5157-211-631-AX	COVER, CLY. HEAD	1	315721-1631A	
73	5158-211-632-BX	COVER, CLY.	1	315821-1632B	
74	5158-011-482-AX	BOLT	4	315801-1482A	
75	5130-B06-12X-XX	BOLT/M6x12	5	130B0612	
76	5158-015-210-AX	GOVERNOR ARM ASSY	1	315801-5210A	
77	5112-B06-30X-XX	•BOLT/M6x30	1	112B0630	
78	5311-B06-00X-XX	•NUT/M6	1	311B0600	

Ref. No.	Part No.	Description	Q'ty	Remarks
79	5411-B06-00X-XX	WASHER, PL/M6	1	411B0600
80	5158-015-231-BX	LINK, GOVERNOR	1	315801-5231B
81	5158-015-232-BX	SPRING, LINK	1	315801-5232B
82	5158-015-310-AX	LEVER, CONTROL	1	315801-5310A
83	5158-015-314-AX	SPRING, GOVERNOR	1	315801-5314A
84	5158-015-317-BX	SPRING, RETURN	1	315801-5317B
85	5158-015-335-AX	BRACKET	1	315801-5335A
86	5158-015-337-AX	BRACKET	1	315801-5337A
87	5144-015-383-AX	WASHER	1	314401-5383A
88	5144-015-385-AX	NUT	1	314401-5385A
89	5144-015-388-AX	SPRING	1	314401-5388A
90	5158-015-321-AX	SPRING	1	315801-5321A
91	5166-715-381-AX	BOLT	1	316671-5381A
92	5158-235-382-AX	BOLT	1	315823-5382A
93	5322-015-351-00	WIRE	1	332201-5351-00
94	5322-015-352-00	CLAMP	1	332201-5352-00
95	5130-B06-16X-XX	BOLT/M6x16	2	130B0616
96	5214-B05-16A-XX	SCREW/M5x16	1	214B0516A
97	5312-B05-00A-XX	NUT/M5	1	312B0500A
98	5158-224-120-AX	SIDE BASE	1	315822-4120A
99	5158-014-124-CX	GASKET	1	315801-4124C
100	5158-014-235-AX	SEAL, OIL	1	315801-4235A
101	5158-254-165-AX	BOLT	1	315825-4165A
102	5410-B08-00X-XX	WASHER, PL/M8	1	410B0800
103	5130-B08-28X-XX	BOLT/M8x28	2	130B0828
104	5130-B08-35X-XX	BOLT/M8x35	6	130B0835
105	5551-A08-16X-XX	PIN, DOWEL	2	551A0816
106	5601-A62-06X-XX	BEARING, RB/6206	2	601A6206
107	5158-015-110-AX	GOVERNOR ASSY	1	315801-5110A
108	5144-015-121-BX	SLEEVE, GOVERNOR	1	314401-5121B
109	5158-015-147-AX	COVER	1	315801-5147A
110	5144-053-092-AX	SCREW, TAPPING	3	314405-3092A
111	5158-015-122-AX	TIP, GOVERNOR	1	315801-5122A
112	5554-A06-00X-XX	PIN, SNAP	1	554A0600
113	5144-015-135-AX	WASHER	1	314401-5135A
114	5410-B06-00X-XX	WASHER, PL/M6	1	410B0600
115	5158-017-411-AX	GAUGE, OIL	1	315801-7411A
116	5151-927-432-00	O-RING	1	315192-7432-00
117	5154-707-441-AX	PLUG, DRAIN	1	315470-7441A

Ref. No.	Part No.	Description	Q'ty	Remarks	
118	5154-707-214-AX	GASKET	1	315470-7214A	
119	5158-018-111-BX	FLYWHEEL	1	315801-8111B	
120	5158-018-103-AX	COIL, IGNITION	1	315801-8103A	
121	5158-018-124-AX	COIL, LIGHTING	1	315801-8124A	
122	5158-018-465-BX	IGNITER	1	315801-8465B	
123	5158-018-164-AX	GROMMET	1	315801-8164A	
124	5158-018-165-AX	GROMMET	1	315801-8165A	
125	5136-2A8-168-00	TUBE	1	31362A-8168-00	
126	5158-016-732-AX	SCREW	2	315801-6732A	
127	5180-B06-25X-XX	BOLT/M6x25	2	180B0625	
128	5180-B06-30X-XX	BOLT/M6x30	2	180B0630	
129	5136-502-371-00	KEY	1	313650-2371-00	
130	5314-B14-00A-XX	NUT/M14	1	314B1400A	
131	5156-013-482-AX	WASHER	1	315601-3482A	
132	5158-228-161-AX	CLAMP	1	315822-8161A	
133	5166-708-161-00	CLAMP	1	316670-8161-00	
134	5130-B06-12X-XX	BOLT/M6x12	1	130B0612	
135	5158-218-410-AX	PLUG, SPARK/NGK BP-4HS	1	315821-8410A	
136	5172-708-418-BX	CAP, PLUG	1	317270-8418B	
137	5172-708-419-AX	SPRING	1	317270-8419A	
138	5157-213-430-AX	RECOIL STARTER ASSY	1	315721-3430A	See Fig. R-1
139	5187-B06-67X-XX	BOLT/M6x67	3	187B0667	
140	5154-830-851-BX	LABEL	1	315483-0851B ☼	
	ACCESSORY				
	5154-700-900-AX	TOOL ASSY	1	315470-0900A ☼	
	5151-200-934-00	WRENCH, SOCKET/17x21	1	315120-0934-00 ☼	
	5151-200-945-00	BAR	1	315120-0945-00 ☼	

Fig. A-1 AIR CLEANER

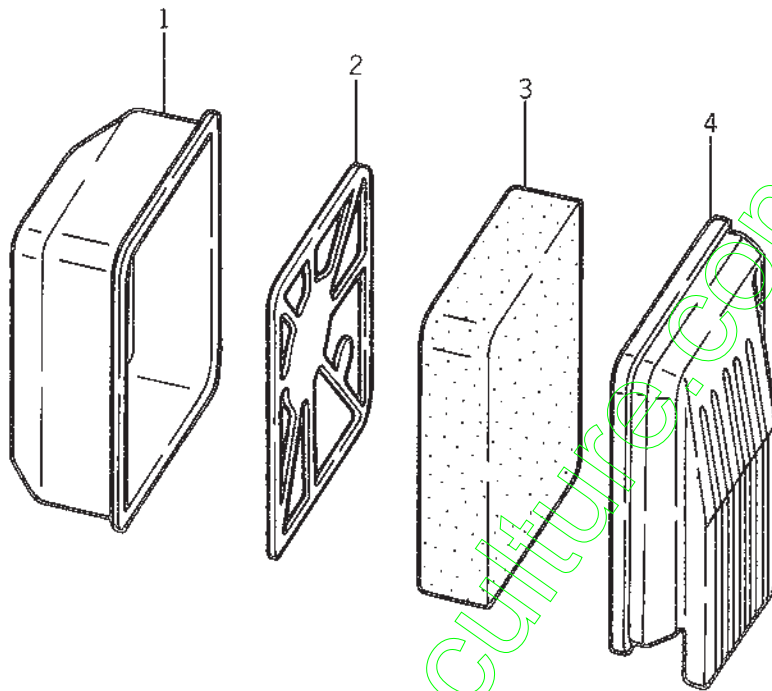

Ref. No.	Part No.	Description	Q'ty	Remarks
	5158-011-310-AX	AIR CLEANER ASSY	1	315801-1310A
A-1- 1	5158-011-311-AX	CASE, AIR CLEANER	1	315801-1311A
A-1- 2	5158-011-327-AX	PLATE	1	315801-1327A
A-1- 3	5158-011-312-AX	ELEMENT	1	315801-1312A
A-1- 4	5158-011-313-AX	COVER, AIR CLEANER	1	315801-1313A

Fig. C-1 CARBURETOR

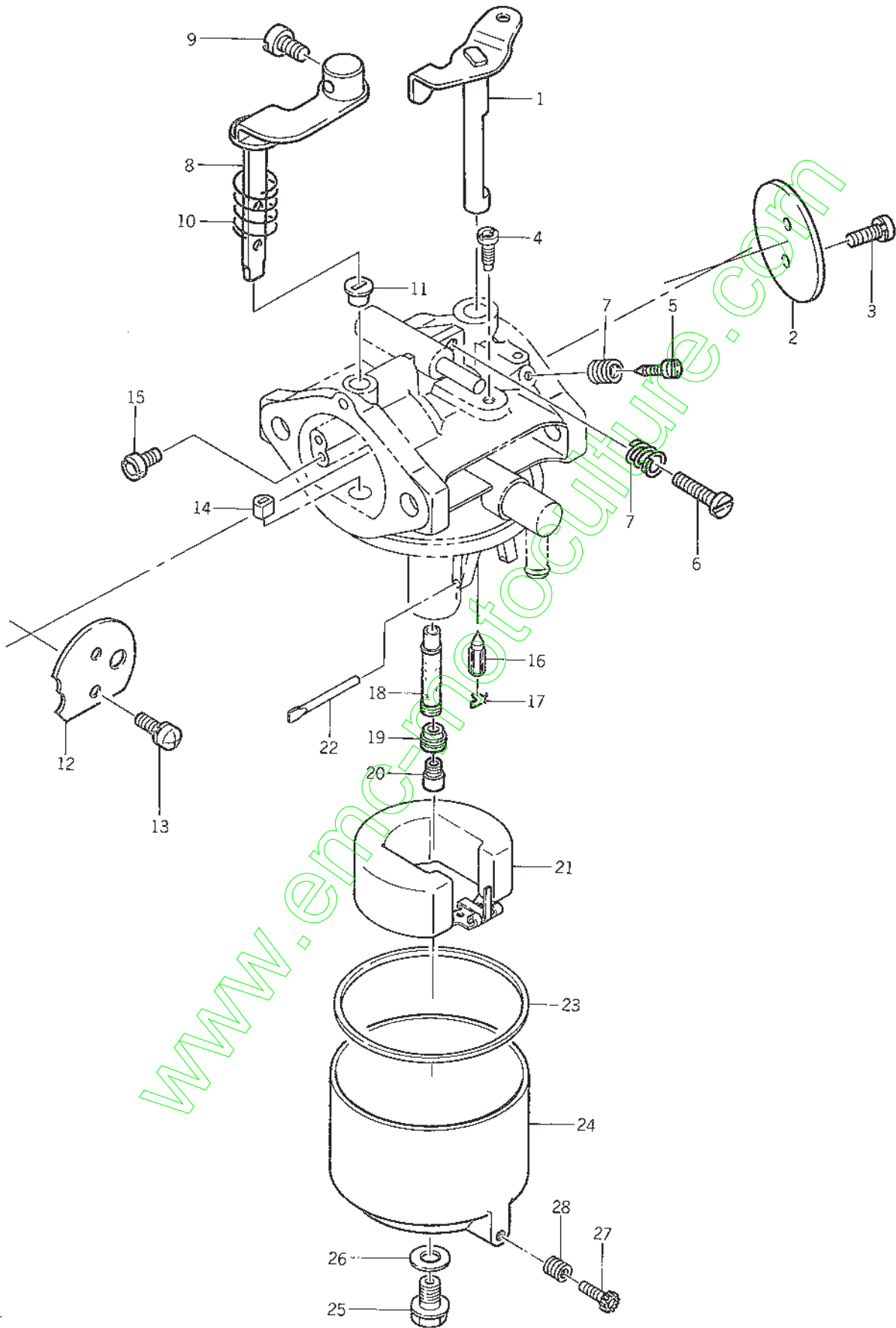

Ref. No.	Part No.	Description	Q'ty	Remarks
	5157-216-100-AX	CARBURETOR ASSY	1	315721-6100A
C-1- 1	5158-236-139-AX	.SHAFT, THROTTLE	1	315823-6139A
C-1- 2	5166-706-101-AX	.VALVE, THROTTLE/#110	1	316670-6101A
C-1- 3	5165-506-137-AX	.SCREW	2	316550-6137A
C-1- 4	5136-506-112-00	.JET, PILOT/#45	1	313650-6112-00
C-1- 5	5136-506-114-00	.SCREW, PILOT	1	313650-6114-00
C-1- 6	5158-236-115-AX	.SCREW, STOP	1	315823-6115A
C-1- 7	5127-506-116-00	.SPRING	2	312750-6116-00
C-1- 8	5157-216-142-AX	.SHAFT, CHOKE	1	315721-6142A
C-1- 9	5172-906-141-00	.BOLT	1	317290-6141-00
C-1-10	5158-256-103-AX	.SPRING	1	315825-6103A
C-1-11	5145-986-157-AX	.COLLAR	2	314598-6157A
C-1-12	5157-216-102-AX	.VALVE, CHOKE	1	315721-6102A
C-1-13	5136-506-134-00	.SCREW	2	313650-6134-00
C-1-14	5145-986-138-AX	.COLLAR	1	314598-6138A
C-1-15	5157-216-113-AX	.JET, AIR/#1.6	1	315721-6113A
C-1-16	5158-236-122-AX	.VALVE, NEEDLE	1	315823-6122A
C-1-17	5157-216-134-AX	.CLIP	1	315721-6134A
C-1-18	5157-216-129-AX	.NOZZLE, MAIN/#6A	1	315721-6129A
C-1-19	5157-216-155-AX	.HOLDER, MAIN JET	1	315721-6155A
C-1-20	5158-016-132-AX	.JET, MAIN/#87.5	1	315801-6132A
C-1-21	5158-016-126-AX	.FLOAT	1	315801-6126A
C-1-22	5144-996-127-AX	.PIN, FLOAT	1	314499-6127A
C-1-23	5136-506-128-00	.GASKET	1	313650-6128-00
C-1-24	5158-236-130-AX	.CHAMBER, FLOAT	1	315823-6130A
C-1-25	5145-966-143-AX	.BOLT	1	314596-6143A
C-1-26	5144-996-159-AX	.WASHER	1	314499-6159A
C-1-27	5158-226-133-AX	.SCREW, DRAIN	1	315822-6133A
C-1-28	5131-226-116-00	.SPRING	1	313122-6116-00

Fig. F-1 FILTER

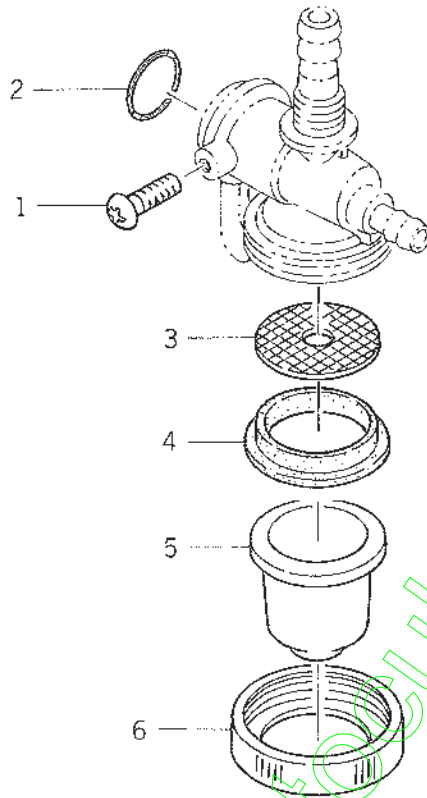

Ref. No.	Part No.	Description	Q'ty	Remarks
	5136-506-510-02	FILTER ASSY	1	313650-6510-02
F-1- 1	5136-506-517-00	•SCREW	1	313650-6517-00
F-1- 2	5136-506-512-00	•O-RING	1	313650-6512-00
F-1- 3	5136-506-519-00	•STRAINER	1	313650-6519-00
F-1- 4	5136-506-518-02	•GASKET	1	313650-6518-02
F-1- 5	5136-506-521-00	•POT, FILTER	1	313650-6521-00
F-1- 6	5136-506-522-00	•NUT, RING	1	313650-6522-00

Fig. R-1 RECOIL STARTER

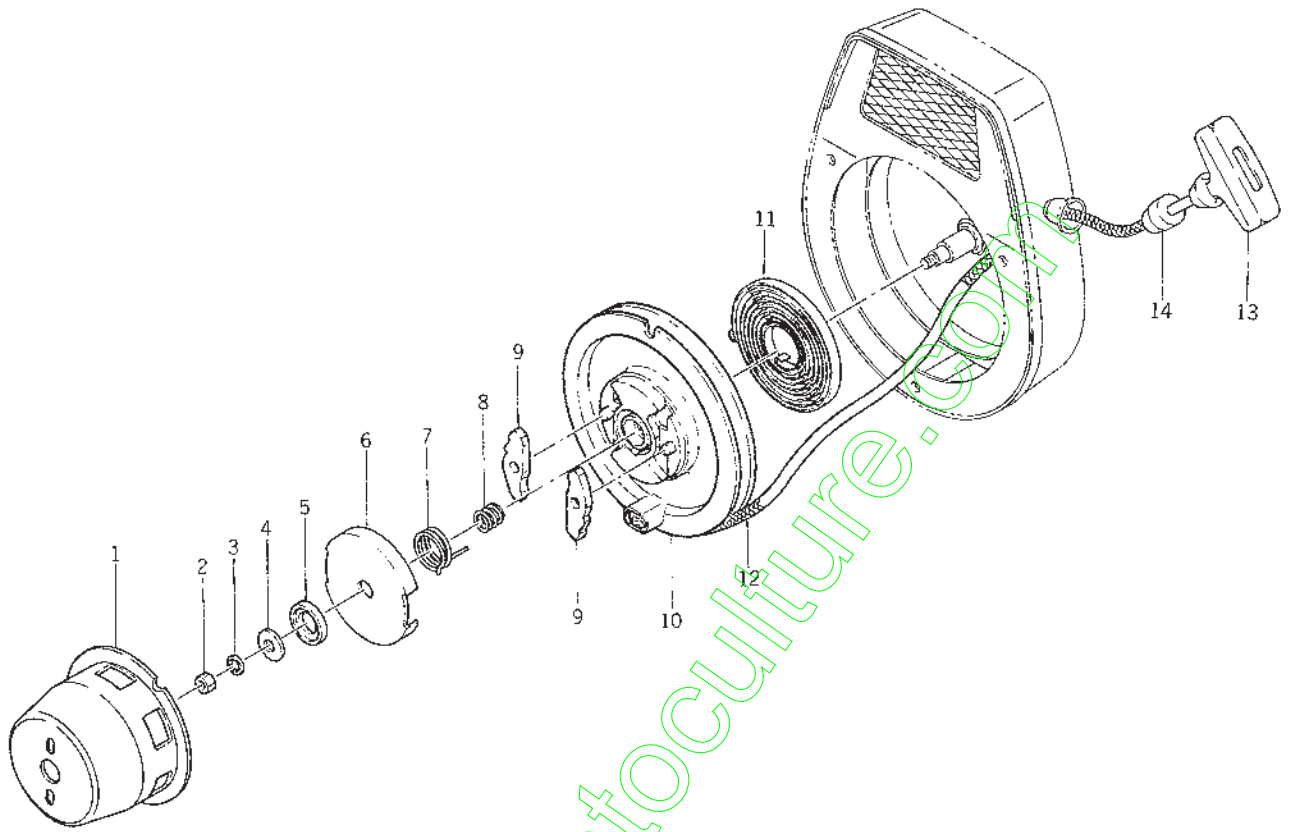

Ref. No.	Part No.	Description	Q'ty	Remarks
	5157-213-430-AX	RECOIL STARTER ASSY	1	315721-3430A
R-1- 1	5157-213-432-AX	•PULLEY	1	315721-3432A
R-1- 2	5311-B06-00X-XX	•NUT/M6	1	311B0600
R-1- 3	5461-F06-00A-XX	•WASHER, SP/M6	1	461F0600A
R-1- 4	5164-203-442-BX	•WASHER, THRUST	1	316420-3442B
R-1- 5	5164-513-456-AX	•WASHER, THRUST	1	316451-3456A
R-1- 6	5164-203-449-BX	•COVER, RETAINER	1	316420-3449B
R-1- 7	5164-703-448-AX	•SPRING, RETURN	1	316470-3448A
R-1- 8	5164-203-446-AX	•SPRING	1	316420-3446A
R-1- 9	5164-203-445-BX	•PAWL, RECOIL	2	316420-3445B
R-1-10	5164-513-441-AX	•REEL, RECOIL	1	316451-3441A
R-1-11	5188-633-452-00	•SPRING, RECOIL	1	318863-3452-00
R-1-12	5157-213-453-AX	•ROPE/6x2720	1	315721-3453A
R-1-13	5122-113-454-00	•HANDLE, RECOIL STARTER	1	312211-3454-00
R-1-14	5153-533-455-00	•DAMPER	1	315353-3455-00

CHASSIS

www.emc-motoculture.com

www.emc-motoculture.com

CONTENTS

KS652-HE40 CHASSIS

	Page
Fig. 1 FRAME and FENDER	13
Fig. 2 MAIN GEAR CASE	15
Fig. 3 TRANSMISSION GEAR	17
Fig. 4 SHIFTER	19
Fig. 5 TENSION and BRAKE SYSTEM	21
Fig. 6 HANDLE FRAME	25
Fig. 7 HANDLE REVOLUTION ASSY	29
Fig. 8 CONTROL LEVER	31
Fig. 9 WHEEL	34
Fig. 10 BONNET and FUEL TANK	35
Fig. 11 MARKS	37
Fig. 12 TOOLS	38

www.emc-motoculture.com

Fig.1 FRAME and FENDER

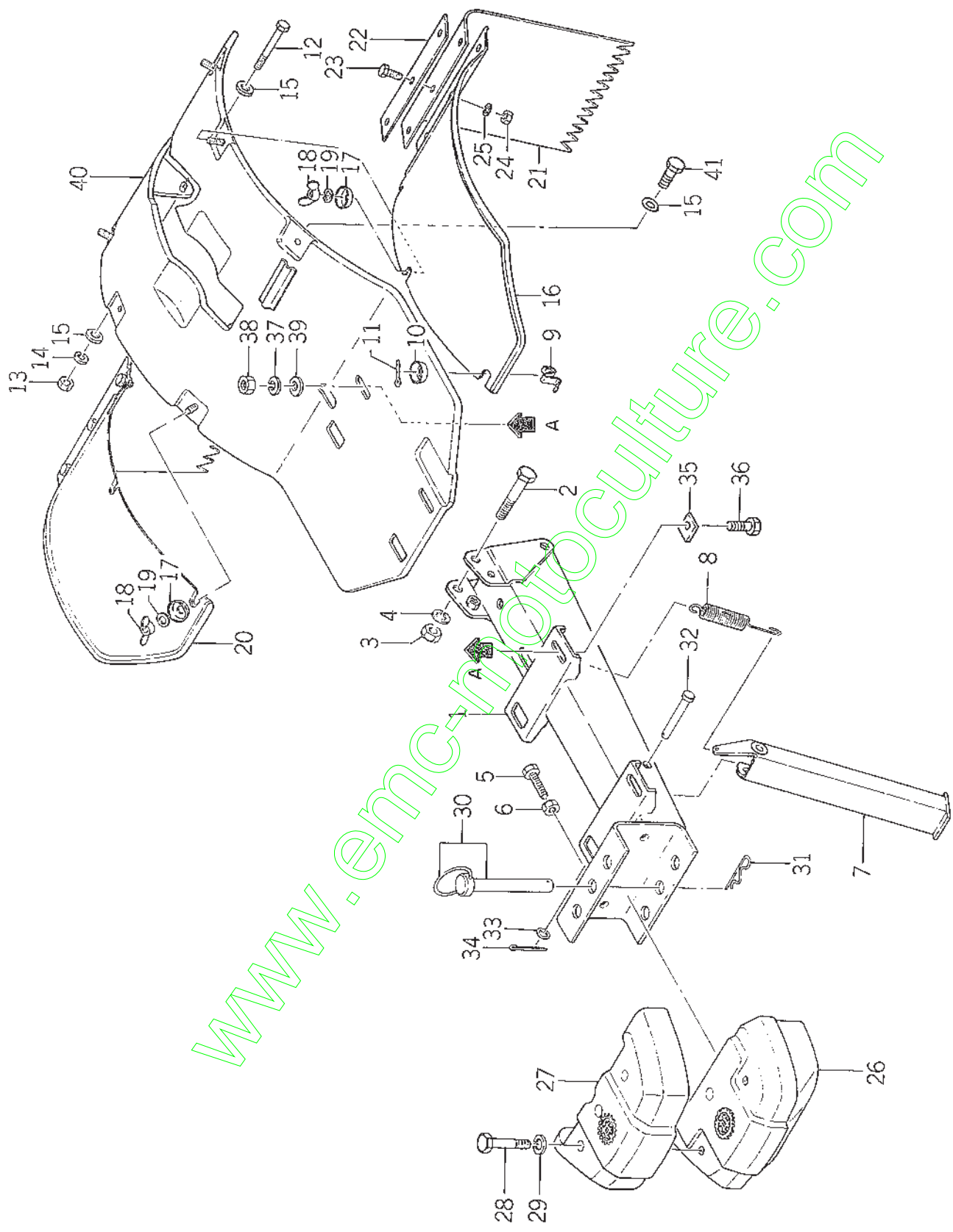

Ref.No.	Parts No.	Description	Q'ty	Remarks
1- 1	1392-101-200-00	FRAME, F	1	
1- 2	V201-461-207-50	BOLT/M12x75 9T	2	
1- 3	V300-260-012-00	NUT/M12	2	
1- 4	V401-160-012-00	WASHER, SP/M12	2	
1- 5	W201-261-003-50	BOLT/M10x35 S=35	2	
1- 6	V300-260-010-00	NUT/M10	2	
1- 7	1352-006-100-00	STAND	1	
1- 8	1352-106-002-00	SPRING, STAND	1	
1- 9	1352-616-001-00	SPRING, PLATE	2	
1-10	1352-616-002-00	WASHER, CONE	2	
1-11	V500-153-001-50	PIN, SPLIT/3x15	2	
1-12	V201-260-808-08	BOLT/M8x80	1	
1-13	V300-260-008-00	NUT/M8	1	
1-14	V401-160-008-00	WASHER, SP/M8	3	
1-15	V413-160-008-00	WASHER/M8	4	
1-16	1365-616-200-00	FENDER, AUX LH	1	
1-17	1352-616-002-00	WASHER, CONE	4	
1-18	V371-160-008-00	NUT, WING/M8	4	
1-19	V401-160-008-00	WASHER, SP/M8	4	
1-20	1365-616-300-00	FENDER, AUX RH	1	
1-21	1352-616-003-00	GUARD, MAD	2	
1-22	1352-161-004-00	PLATE, SET	2	
1-23	V200-160-601-20	BOLT/M6x12	6	
1-24	V300-260-006-00	NUT/M6	6	
1-25	V411-160-006-00	WASHER, SP/M6	6	
1-26	1352-931-001-00	WEIGHT, F A	1	
1-27	1352-931-002-00	WEIGHT, F B	1	
1-28	V201-261-206-00	BOLT/M12x60	2	
1-29	V401-160-012-00	WASHER, SP/M12	2	
1-30	1390-931-200-00	PIN, KING ASSY	1	
1-31	1305-931-003-00	-PIN, HAIR	1	
1-32	1352-106-001-00	PIN (10x50)	1	
1-33	V413-160-010-00	WASHER/M10	1	
1-34	V500-152-502-00	PIN, SPLIT/2.5x20	1	
1-35	1392-121-001-00	PLATE	4	
1-36	V201-261-004-50	BOLT/M10x45	4	
1-37	V401-160-010-00	WASHER, SP/M10	4	
1-38	V300-260-010-00	NUT/M10	4	
1-39	V413-160-010-00	WASHER/M10	4	
1-40	1392-616-200-00	FENDER	1	
1-41	V201-260-802-00	BOLT/M8x20	2	

Fig.2 MAIN GEAR CASE

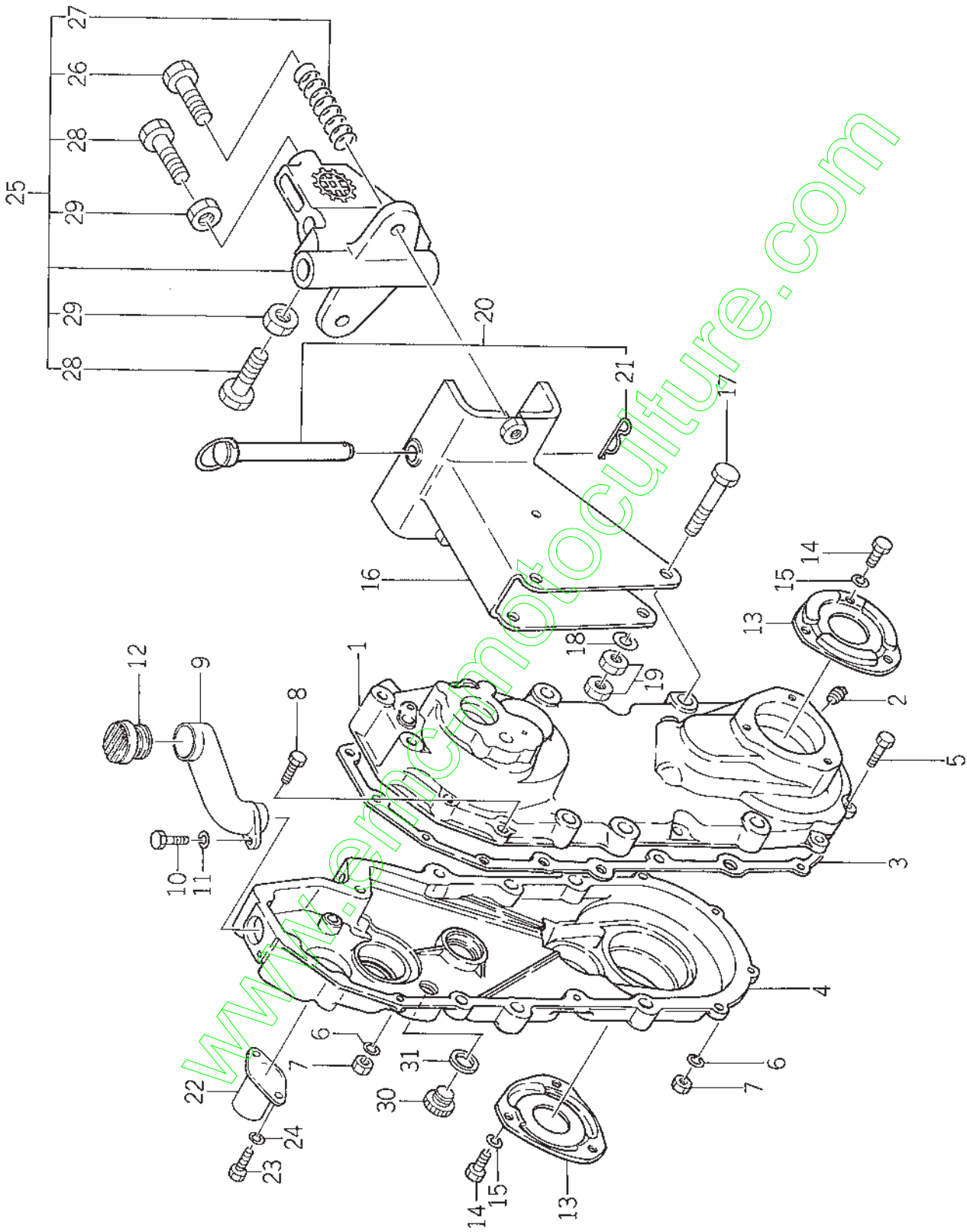

Ref.No.	Parts No.	Description	Q'ty	Remarks
2- 1	1365-216-001-30	CASE, MAIN GEAR LH	1	
2- 2	V781-300-000-60	PLUG/PT3/8	1	
2- 3	1365-216-005-00	PACKING, MAIN GEAR CASE	1	
2- 4	1365-216-002-30	CASE, MAIN GEAR RH	1	
2- 5	V201-260-802-50	BOLT/M8x25	6	
2- 6	V401-260-008-00	WASHER, SP/M8	7	
2- 7	V300-260-008-00	NUT/M8	7	
2- 8	V201-260-803-50	BOLT/M8x35	1	
2- 9	1352-216-004-00	PIPE, OIL	1	
2-10	V200-260-601-60	BOLT/M6x16	1	
2-11	V401-260-006-00	WASHER, SP/M6	1	
2-12	7954-205-101-00	CAP, OIL/30	1	
2-13	1365-216-003-00	METAL, WHEEL	2	
2-14	V200-260-601-20	BOLT/M6x12	6	
2-15	V401-260-006-00	WASHER, SP/M6	6	
2-16	1390-930-200-10	HITCH, R	1	
2-17	V201-461-207-50	BOLT/M12x75 9T	2	
2-18	V401-160-012-00	WASHER, SP/M12	2	
2-19	V300-260-012-00	NUT/M12	2	
2-20	1390-931-200-00	PIN, KING ASSY	1	
2-21	1305-931-003-00	· PIN, HAIR	1	
2-22	1365-216-004-00	CAP, SHAFT/30x50	1	
2-23	V200-260-601-00	BOLT/M6x10	2	
2-24	V401-260-006-00	WASHER, SP/M6	2	
2-25	8057-006-000-00	HITCH, CULTI ASSY	1	
2-26	8057-006-002-00	· BOLT	2	
2-27	8057-006-003-00	· SPRING	2	
2-28	W201-261-204-00	· BOLT/M12x40 S=40	2	
2-29	V302-260-012-00	· NUT/M12	2	
2-30	1343-216-002-00	PLUG	1	
2-31	1343-216-003-00	PACKING	1	

Fig.3 TRANSMISSION GEAR

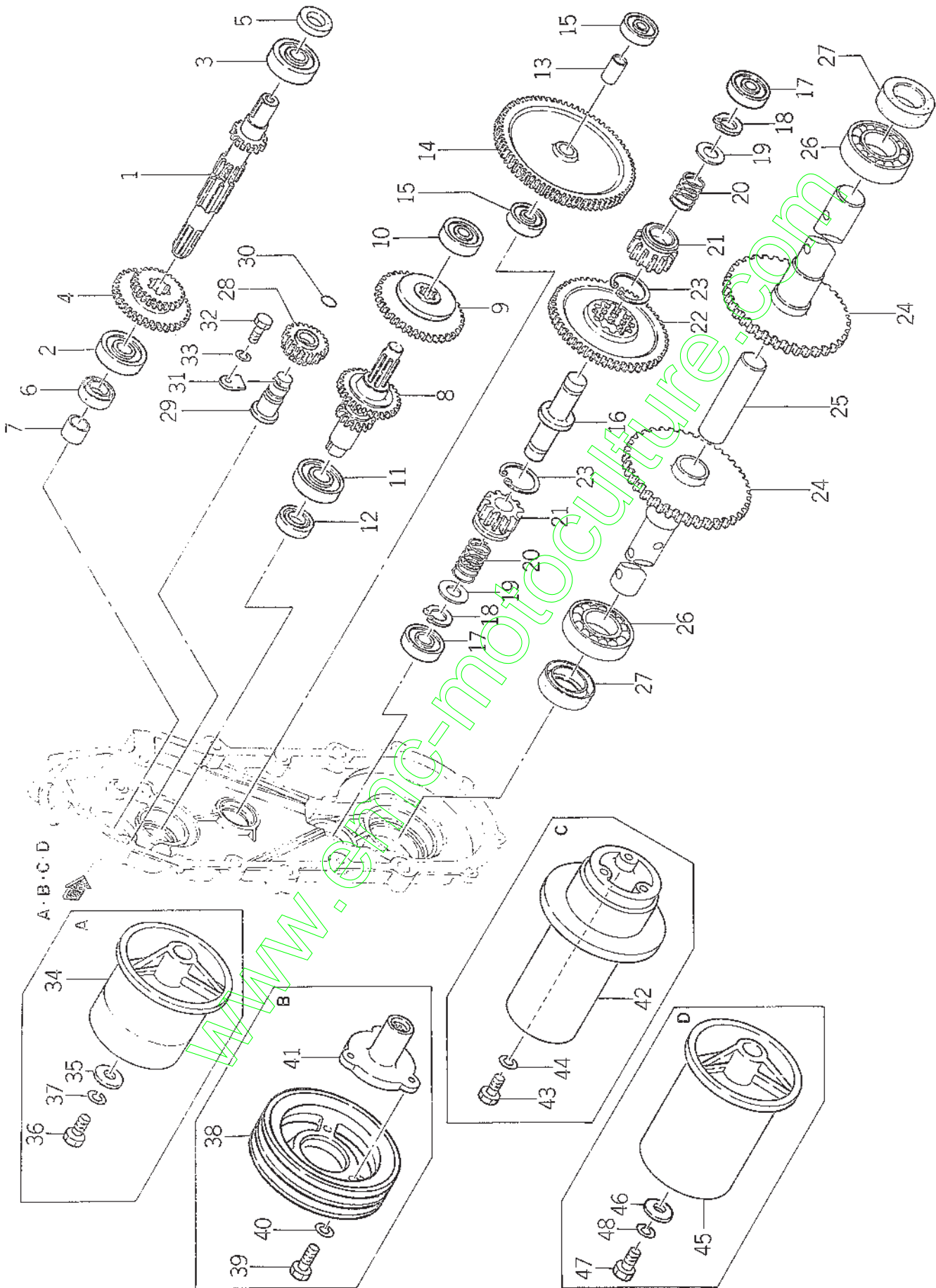

Ref.No.	Parts No.	Description	Q'ty	Remarks
3- 1	1390-217-001-00	SHAFT, MAIN	1	
3- 2	V600-110-630-40	BEARING, RB/6304	1	
3- 3	V600-116-204-50	BEARING, RB/6204 1/2	1	
3- 4	1352-217-002-00	GEAR, MAIN CHANGE/25-39T	1	
3- 5	1340-217-004-00	SEAL, OIL/TC22357	1	
3- 6	1352-217-003-00	SEAL, OIL/TC25358	1	
3- 7	1352-217-004-00	BUSH, SEAL/SI202513	1	
3- 8	1352-219-100-00	SHAFT, CHANGE	1	
3- 9	1390-219-001-00	GEAR, CHANGE/45T	1	
3-10	V600-110-620-30	BEARING, RB/6203	1	
3-11	V600-116-204-50	BEARING, RB/6204 1/2	1	
3-12	1340-217-004-00	SEAL, OIL/TC22357	1	
3-13	1352-222-001-00	PIN, COUNTER GEAR	1	
3-14	1352-222-002-00	GEAR, IDLE/72T	1	
3-15	V600-110-620-20	BEARING, RB/6202	2	
3-16	1365-224-001-00	SHAFT, WHEEL PINION	1	
3-17	V600-110-630-40	BEARING, RB/6304	2	
3-18	V704-140-020-00	RING, SNAP/C20	2	
3-19	1365-224-002-00	WASHER	4	
3-20	1352-224-002-00	SPRING, PRESS/35	2	
3-21	1365-224-003-00	PINION, WHEEL/11T	2	
3-22	1352-224-004-00	GEAR, SIDE CLUTCH/62T	1	
3-23	V705-140-035-00	RING, SNAP/ C35	2	
3-24	1365-225-100-00	SHAFT, WHEEL	2	
3-25	1310-225-005-00	PIN, WHEEL SHAFT	1	
3-26	V600-110-620-80	BEARING, RB/6208	2	
3-27	1365-225-001-00	SEAL, OIL/AQ6952E	2	
3-28	1390-226-200-00	GEAR, BACK/16-20T	1	
3-29	1390-226-001-00	PIN, BACK GEAR	1	
3-30	V720-102-401-00	O-RING/P10A	1	
3-31	1390-226-002-00	PLATE, LOCK	1	
3-32	V200-260-601-20	BOLT/M6x12	1	
3-33	V401-160-006-00	WASHER, SP/M6	1	
3-34	1352-917-001-00	PULLEY/100	1	
3-35	1324-205-002-00	WASHER	1	
3-36	V201-260-802-00	BOLT/M8x20	1	
3-37	V401-160-008-00	WASHER, SP/M8	1	
3-38	1352-917-003-00	PULLEY, V/2-140	1	
3-39	V201-260-802-00	BOLT/M8x20	3	for MAIN SHAFT
3-40	V401-160-008-00	WASHER, SP/M8	3	
3-41	1352-917-004-00	BOSS, PULLEY	1	
3-42	1352-917-002-00	PULLEY/ 90 ENGINE	1	
3-43	V201-260-803-50	BOLT/M8x35	3	
3-44	V401-160-008-00	WASHER, SP/M8	3	
3-45	1352-917-005-00	PULLEY/ 140	1	
3-46	1324-205-002-00	WASHER	1	
3-47	V201-260-802-00	BOLT/M8x20	1	
3-48	V401-160-008-00	WASHER, SP/M8	1	

Fig.4 SHIFTER

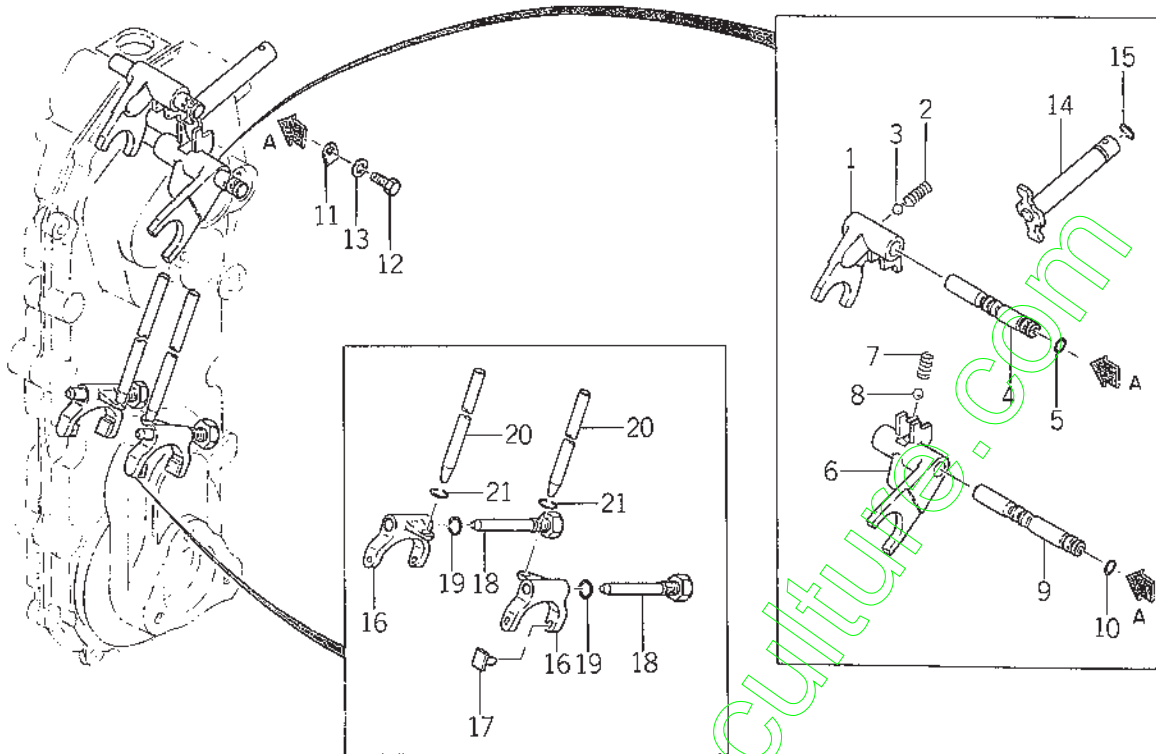

Ref.No.	Parts No.	Description	Q'ty	Remarks
4- 1	1352-229-001-00	SHIFTER, MAIN CHANGE	1	
4- 2	1302-225-003-00	SPRING, SHIFTER	1	
4- 3	V680-200-001-00	BALL, STEEL	1	
4- 4	1352-229-002-00	STAY, MAIN SHIFTER	1	
4- 5	V720-101-900-90	O-RING/P9	1	
4- 6	1352-229-003-10	SHIFTER, BACK CHANGE	1	
4- 7	1302-225-003-00	SPRING, SHIFTER	1	
4- 8	V680-200-001-00	BALL, STEEL	1	
4- 9	1352-229-004-00	STAY, BACK SHIFTER	1	
4-10	V720-101-900-90	O-RING/P9	1	
4-11	1352-229-005-00	PLATE, STAY SET	2	
4-12	V200-260-601-20	BOLT/M6x12	2	
4-13	V401-260-006-00	WASHER, SP/M6	2	
4-14	1352-229-100-00	ARM, CHANGE	1	
4-15	V720-102-401-60	O-RING/P16	1	
4-16	1365-229-001-00	SHIFTER, SIDE CLUTCH	2	
4-17	1703-101-020-00	COLLAR, SHIFTER	4	
4-18	1352-229-006-00	PIN, SIDE CLUTCH	2	
4-19	V720-102-401-00	O-RING/P10A	2	
4-20	1352-229-007-00	ROD, SIDE CLUTCH	2	
4-21	V720-101-901-00	O-RING/P10	2	

SERVICE MEMO

.....
.....
.....
.....
.....
.....
.....
.....
.....
.....
.....
.....
.....
.....
.....
.....
.....
.....
.....
.....
.....
.....
.....
.....
.....
.....
.....
.....
.....
.....
.....
.....
.....
.....
.....
.....
.....
.....
.....
.....
.....

www.enc-motoculture.com

Fig.5 TENSION and BRAKE SYSTEM

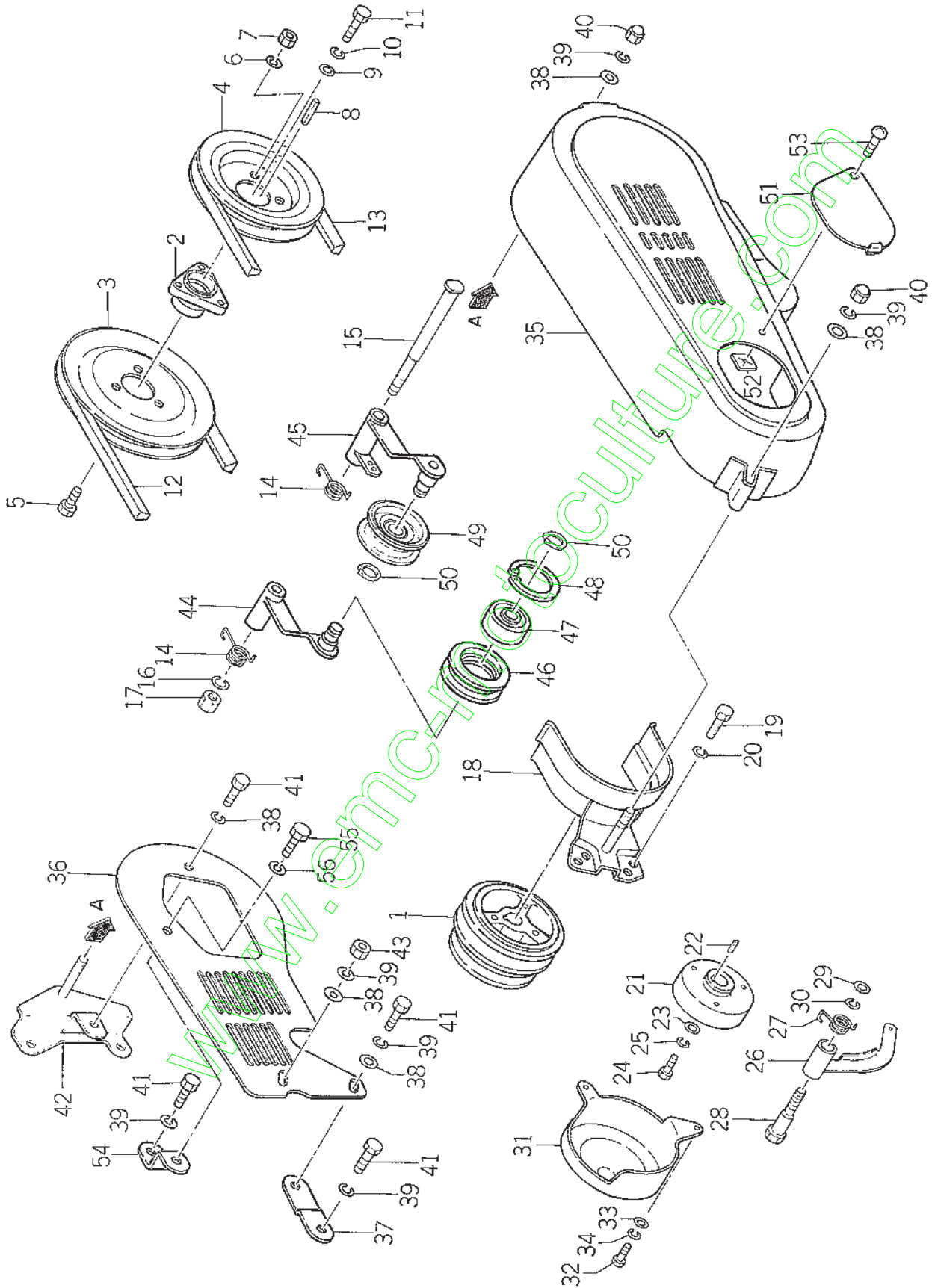

Ref.No.	Parts No.	Description	Q'ty	Remarks
5- 1	1390-201-001-10	PULLEY, ENGINE/ 82-98	1	
5- 2	1390-201-002-00	BOSS, PULLEY	1	
5- 3	1390-201-003-10	V-PULLEY /164	1	
5- 4	1352-201-202-00	V-PULLEY /141	1	
5- 5	V201-260-803-50	BOLT/M8x35	3	
5- 6	V401-160-008-00	WASHER, SP/M8	3	
5- 7	V300-260-008-00	NUT/M8	3	
5- 8	1317-201-004-00	KEY	1	
5- 9	1324-205-002-00	WASHER	1	
5-10	V401-160-008-00	WASHER, SP/M8	1	
5-11	V201-260-802-00	BOLT/M8x20	1	
5-12	1390-201-004-00	V-BELT/HPSC40-2	1	
5-13	V817-200-040-00	V-BELT/SB40 RED	1	
5-14	1352-202-001-00	SPRING, TORQUE/28	2	
5-15	1365-202-002-00	BOLT, TENSION	1	
5-16	V401-160-012-00	WASHER, SP/M12	1	
5-17	V300-260-012-00	NUT/M12	1	
5-18	1392-204-200-00	STOPPER, BELT	1	
5-19	V201-260-801-60	BOLT/M8x16	2	
5-20	V401-160-008-00	WASHER, SP/M8	2	
5-21	1352-209-001-00	DRUM, BRAKE	1	
5-22	1352-209-002-00	KEY/ 5x5x21	1	
5-23	1324-205-002-00	WASHER	1	
5-24	V201-260-802-00	BOLT/M8x20	1	
5-25	V401-160-008-00	WASHER, SP/M8	1	
5-26	1352-209-100-00	SHOE, BRAKE	1	
5-27	1352-209-003-10	SPRING, TORQUE/25	1	
5-28	1352-209-004-00	BOLT, BRAKE	1	
5-29	V413-160-010-00	WASHER/M10	1	
5-30	V401-260-010-00	WASHER, SP/M10	1	
5-31	1352-209-005-10	COVER, BRAKE	1	
5-32	V200-260-601-20	BOLT/M6x12	2	
5-33	V413-160-006-00	WASHER/M6	2	
5-34	V401-260-006-00	WASHER, SP/M6	2	
5-35	1392-611-200-00	COVER, BELT A	1	
5-36	1392-611-001-00	COVER, BELT B	1	
5-37	1390-612-200-00	STAY, COVER A	1	
5-38	V413-160-008-00	WASHER/M8	5	
5-39	V401-160-008-00	WASHER, SP/M8	7	
5-40	V340-160-008-00	NUT, LOCK/M8	2	
5-41	V201-260-801-60	BOLT/M8x16	4	
5-42	1390-612-210-00	STAY, COVER B	1	
5-43	V300-260-008-00	NUT/M8	1	
5-44	1390-203-200-00	ARM, TENSION A	1	
5-45	1390-203-220-00	ARM, TENSION B	1	
5-46	1385-202-001-00	TENSION PULLEY/ 56	1	
5-47	V600-150-630-20	BEARING, RB/6202SS	1	
5-48	V705-140-042-00	RING, SNAP/C42	1	
5-49	1352-202-300-00	PULLEY, TENSION	1	
5-50	V704-140-015-00	RING, SNAP/C15	2	
5-51	1365-611-001-00	CAP, COVER	1	
5-52	1365-611-002-00	NUT, SPEED U /M6x10	1	

Ref.No.	Parts No.	Description	Q'ty	Remarks
5-53	V111-166-001-00	SCREW/M6x10	1	
5-54	1390-612-220-00	STAY, COVER C	1	
5-55	V201-260-801-60	BOLT/M8x16	1	
5-56	V401-160-008-00	WASHER, SP/M8	1	

www.emc-motoculture.com

SERVICE MEMO

20
21
22
23
24
25
26
27
28
29
30
31
32
33
34
35
36
37
38
39
40
41
42
43
44
45
46
47
48
49
50
51
52
53
54
55
56
57
58
59
60
61
62
63
64
65
66
67
68
69
70
71
72
73
74
75
76
77
78
79
80
81
82
83
84
85
86
87
88
89
90
91
92
93
94
95
96
97
98
99
100

www.enc-motoculture.com

Fig.6 HANDLE FRAME

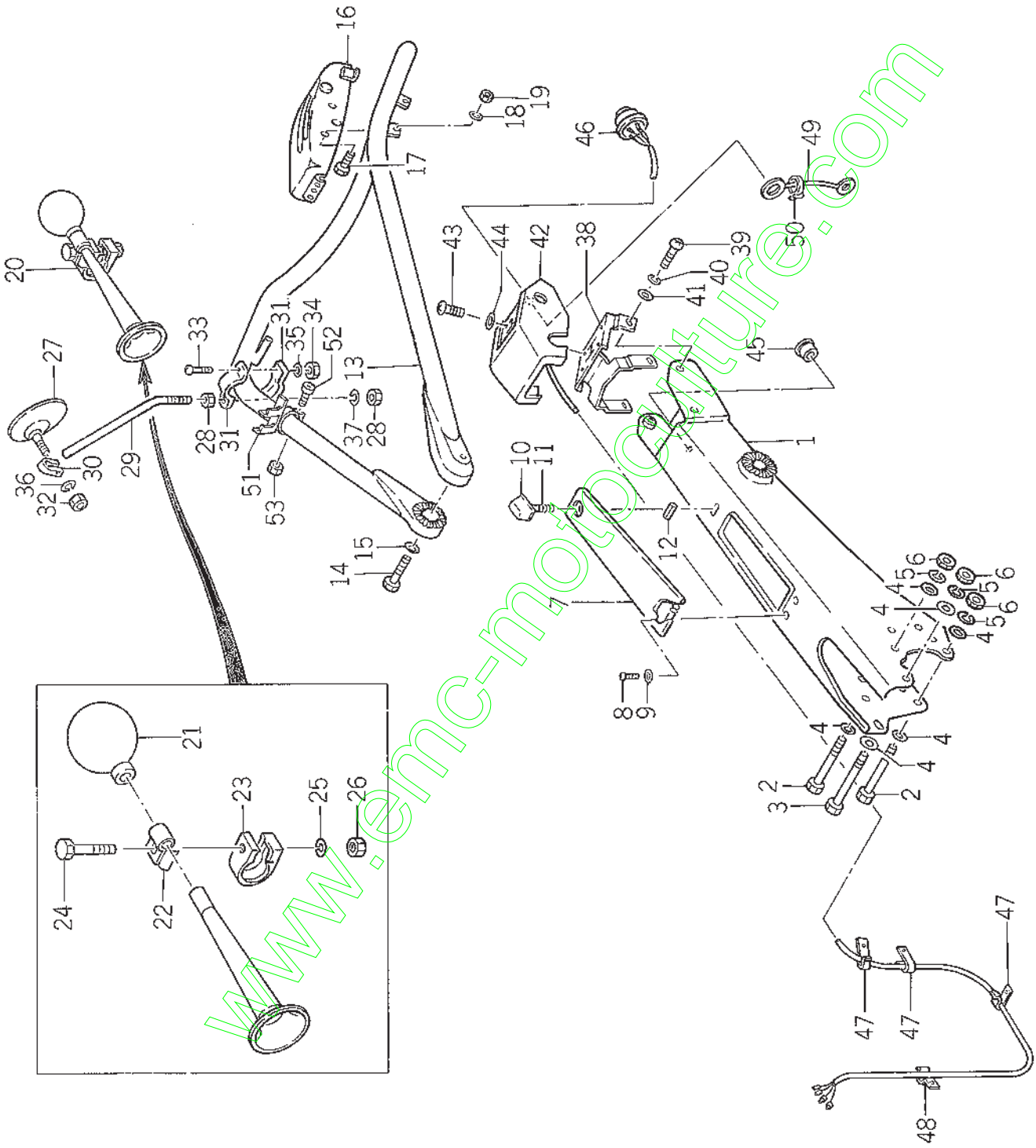

Ref.No.	Parts No.	Description	Q'ty	Remarks
6- 1	1368-301-100-40	FRAME, HANDLE	1	
6- 2	V201-261-012-00	BOLT/M10x120	2	
6- 3	V201-261-012-50	BOLT/M10x125	1	
6- 4	V413-160-010-00	WASHER/M10	6	
6- 5	V401-260-010-00	WASHER, SP/M10	3	
6- 6	V300-260-010-00	NUT/M10	3	
6- 7	1365-301-200-10	COVER, BOX	1	
6- 8	V111-165-001-00	SCREW/M5x10	2	
6- 9	V401-160-005-00	WASHER, SP/M5	2	
6-10	1352-301-001-00	KNOB, SET	1	
6-11	1352-301-002-00	SPRING, PRESS/14	1	
6-12	V580-140-301-80	PIN, SPRING/W 3x18	1	
6-13	1352-311-100-00	PIPE, HANDLE	1	
6-14	V201-461-204-50	BOLT/M12x45 9T	2	
6-15	V401-260-012-00	WASHER, SP/M12	2	
6-16	1392-401-200-00	BOX, CLUTCH	1	
6-17	V201-260-801-60	BOLT/M8x16	2	
6-18	V401-160-008-00	WASHER, SP/M8	2	
6-19	V300-260-008-00	NUT/M8	2	
6-20	1352-600-052-00	HORN ASSY	1	
6-21	1352-621-003-00	• GRIP	1	
6-22	1352-621-004-00	• BAND	1	
6-23	1366-651-002-00	• BAND/27	1	
6-24	V201-261-005-00	• BOLT/M10x50	1	
6-25	V401-260-010-00	• WASHER, SP/M10	1	
6-26	V300-260-010-00	• NUT/M10	1	
6- 0-1	1386-622-200-00	MIRROR, R VIEW ASSY	1	
6-27	1386-622-201-00	• MIRROR	1	
6-28	V300-260-010-00	• NUT/M10	2	
6-29	1386-622-202-00	• POLE	1	
6-30	1386-622-204-00	• METAL, SET	1	
6-31	1386-622-203-00	• BAND	2	
6-32	V300-260-008-00	• NUT/M8	1	
6-33	1386-622-205-00	• SCREW	1	
6-34	V300-260-006-00	• NUT/M6	1	
6-35	V401-260-006-00	• WASHER, SP/M6	1	
6-36	V401-260-008-00	• WASHER, SP/M8	1	
6-37	V401-260-010-00	• WASHER, SP/M10	1	
6-38	1392-301-200-00	GUIDE, CHANGE	1	
6-39	V111-166-001-40	SCREW/M6x14	4	
6-40	V401-160-006-00	WASHER, SP/M6	4	
6-41	V413-160-006-00	WASHER/M6	4	
6-42	1392-301-001-00	PANEL, CHANGE	1	
6-43	1392-301-003-00	SCREW/M5x12	4	
6-44	V411-160-005-00	WASHER/M5	4	
6-45	1392-301-005-00	BUSHING /13x15.6x6.4	1	
6-46	1365-600-051-20	SWITCH, MAIN ASSY	1	
6-47	1317-621-002-00	CLAMP, WIRE	3	
6-48	1352-621-001-00	CLAMP	1	
6-49	1392-621-001-00	HARNES, WIRE EARTH	1	
6-50	3746-172-013-00	BAND, HARNES	1	
6-51	1372-121-215-00	HOOK, WIRE	1	

Ref.No.	Parts No.	Description	Q'ty	Remarks
6-52	V111-165-002-50	SCREW/M5x25	1	
6-53	V300-260-005-00	NUT/M5	1	

www.emc-motoculture.com

SERVICE MEMO

Dotted lines for writing.

www.emc-motoculture.com

Fig.7 HANDLE REVOLUTION ASSY

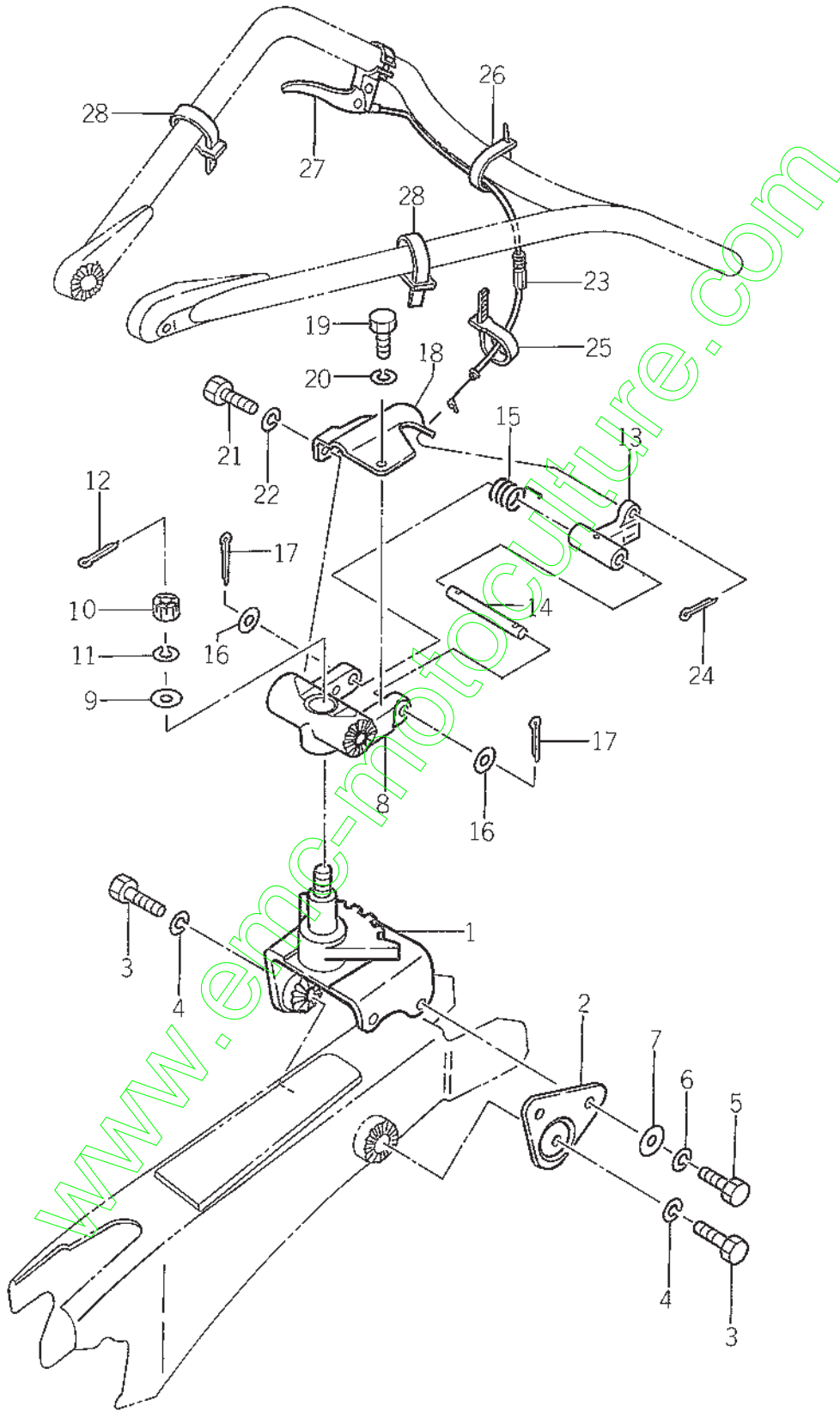

Ref.No.	Parts No.	Description	Q'ty	Remarks
7- 0-1	1372-351-000-00	REVOLUTION, HANDLE ASSY	1	
7- 1	1372-351-200-10	·BRACKET	1	
7- 2	1372-351-210-00	·PLATE, SET	1	
7- 3	V201-461-204-50	·BOLT/M12x45 9T	2	
7- 4	V401-160-012-00	·WASHER, SP/M12	2	
7- 5	V201-461-002-50	·BOLT/M10x25 9T	2	
7- 6	V401-160-010-00	·WASHER, SP/M10	2	
7- 7	V413-160-010-00	·WASHER/M10	2	
7- 8	1372-351-001-00	·METAL, BRACKET	1	
7- 9	1372-351-002-00	·WASHER/17x40x5	1	
7-10	V321-260-016-00	·NUT, SLOTTED/M16	1	
7-11	V401-160-016-00	·WASHER, SP/M16	1	
7-12	V500-154-003-50	·PIN, SPLIT/4x35	1	
7-13	1372-351-003-10	·METAL, LOCK	1	
7-14	1324-353-004-00	·PIN, NAIL	1	
7-15	1324-353-005-00	·SPRING, TORQUE/36	1	
7-16	V413-160-012-00	·WASHER/M12	2	
7-17	V500-153-002-00	·PIN, SPLIT/3x20	2	
7-18	1372-351-004-00	·HOLDER, WIRE	1	
7-19	V201-260-801-60	·BOLT/M8x16	1	
7-20	V401-160-008-00	·WASHER, SP/M8	1	
7-21	V200-260-603-50	·BOLT/M6x35	1	
7-22	V401-160-006-00	·WASHER, SP/M6	1	
7-23	1372-351-005-00	·WIRE, HANDLE LOCK	1	
7-24	V500-152-501-50	·PIN, SPLIT/2.5x15	1	
7-25	1376-402-003-00	·BAND, WIRE/140	1	
7-26	1427-621-026-00	·CLAMP, HARNESS/150	1	
7-27	1372-351-220-00	·LEVER, LOCK ASSY	1	
7-28	1421-621-038-00	BAND, WIRE (170)	2	

Fig.8 CONTROL LEVER

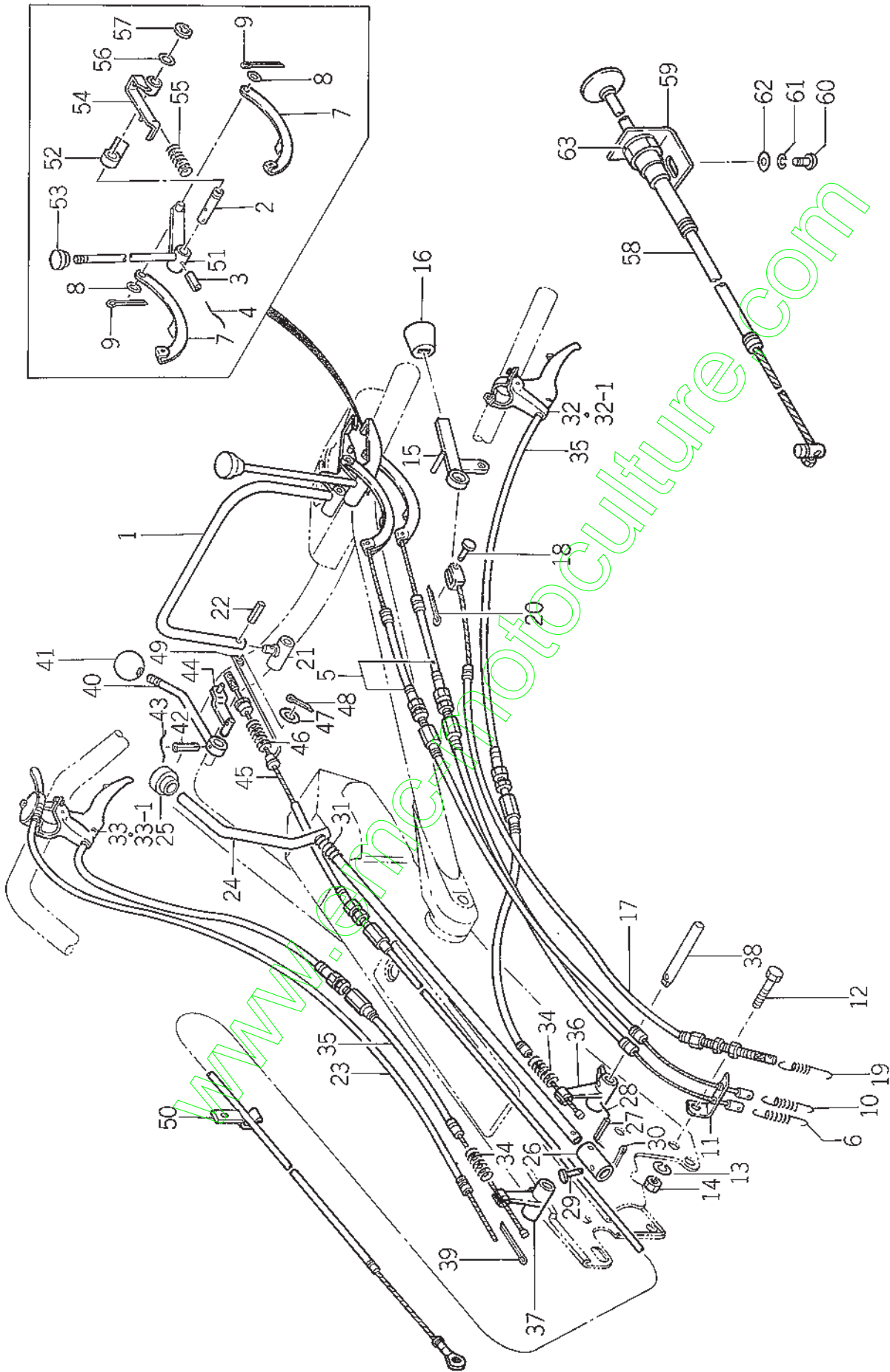

Ref.No.	Parts No.	Description	Q'ty	Remarks
8- 1	1352-404-200-10	LEVER, ARCH	1	
8- 2	1392-401-001-00	PIN, CLUTCH	1	
8- 3	V580-140-402-20	PIN, SPRING/W 4x22	2	
8- 4	V590-130-910-00	WIRE/0.9x100	2	
8- 5	1372-401-001-10	WIRE, CLUTCH	2	
8- 6	1380-401-003-00	SPRING, CLUTCH	1	
8- 7	1352-405-100-00	TRIGGER, WIRE	2	
8- 8	V413-160-008-00	WASHER/M8	2	
8- 9	V500-152-001-40	PIN, SPLIT/2x14	1	
8-10	1352-404-004-00	SPRING, CLUTCH	1	
8-11	1352-404-005-00	STOPPER, WIRE	1	
8-12	V201-260-807-50	BOLT/M8x75	1	
8-13	V401-160-008-00	WASHER, SP/M8	1	
8-14	V300-260-008-00	NUT/M8	1	
8-15	1352-404-600-20	LEVER, BRAKE	1	
8-16	1352-404-007-00	KNOB, LEVER/24	1	
8-17	1372-401-002-00	WIRE, BRAKE	1	
8-18	1352-404-009-00	PIN/6x10	1	
8-19	1352-404-010-00	SPRING, BRAKE	1	
8-20	V500-152-001-40	PIN, SPRING/2x14	1	
8-21	1352-404-800-00	HOLDER, CLUTCH LEVER	1	
8-22	V580-140-301-50	PIN, SPRING/W 3x15	1	
8-23	1372-402-001-00	WIRE, THROTTLE	1	
8-24	1372-451-200-10	LEVER, CHANGE	1	
8-25	3563-102-002-00	GRIP	1	
8-26	1352-403-001-10	JOINT	1	
8-27	V580-140-502-80	PIN, SPRING/W 5x28	1	
8-28	V590-130-908-00	WIRE/0.9x80	1	
8-29	1352-403-002-00	PIN/5x28	1	
8-30	V500-151-601-20	PIN, SPLIT/1.6x12	1	
8-31	1352-403-003-00	SPRING, PRESS/65	1	
8-32	1352-406-200-00	LEVER, SIDE CLUTCH LH ASSY	1	} Interchangeable
8-32-1	1352-400-052-00	LEVER, SIDE CLUTCH LH ASSY	1	
8-33	1352-406-210-00	LEVER, SIDE CLUTCH RH ASSY	1	} Interchangeable
8-33-1	1352-400-051-00	LEVER, SIDE CLUTCH RH ASSY	1	
8-34	1317-406-002-00	SPRING	2	
8-35	1372-406-001-00	WIRE, SIDE CLUTCH	2	
8-36	1352-406-002-00	ARM, SIDE CLUTCH LH	1	
8-37	1352-406-003-00	ARM, SIDE CLUTCH RH	1	
8-38	1352-406-004-00	PIN, SIDE CLUTCH	1	
8-39	V500-153-001-80	PIN, SPLIT/3x18	1	
8-40	1352-416-100-20	LEVER, STAND	1	
8-41	1414-117-004-00	KNOB, LEVER/30	1	
8-42	V580-140-402-20	PIN, SPRING/W 4x22	1	
8-43	V590-102-007-00	WIRE/20x70	1	
8-44	1352-416-200-00	ARM, WIRE	1	
8-45	1352-416-001-10	WIRE, STAND	1	
8-46	1352-416-002-10	SPRING, TENSION/63	1	
8-47	V410-160-008-00	WASHER/M8	2	
8-48	V500-162-001-50	PIN, SPLIT/2x15	2	
8-49	1352-416-003-00	SPRING, STOPPER	1	
8-50	1352-621-001-00	CLAMP	1	

Ref.No.	Parts No.	Description	Q'ty	Remarks
8-51	1352-404-300-10	LEVER, CLUTCH	1	
8-52	1352-404-400-20	ARM, SHIFT A	1	
8-53	2101-230-001-00	KNOB	1	
8-54	1392-401-210-10	ARM, SHIFT B	1	
8-55	1426-621-018-00	SPRING, TENSION	1	
8-56	V411-160-012-00	WASHER/M12	1	
8-57	V710-140-010-00	RING, SNAP/E10	1	
8-58	1352-402-001-00	WIRE, CHOKE	1	
8-59	1392-301-002-00	STAY, CHOKE WIRE	1	
8-60	V111-166-001-40	SCREW/M6x14	1	
8-61	V401-160-006-00	WASHER, SP/M6	1	
8-62	V413-160-006-00	WASHER/M6	1	
8-63	V413-160-010-00	WASHER/M10	1	

www.emc-motoculture.com

Fig.9 WHEEL

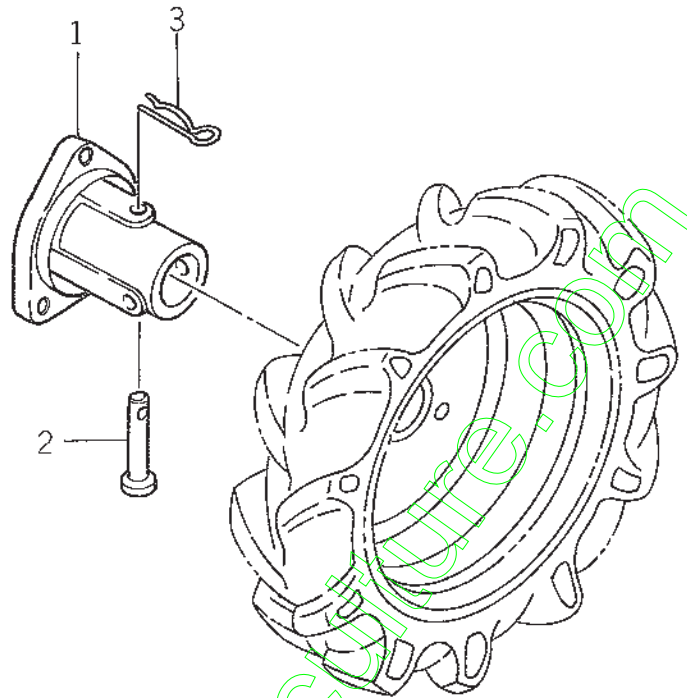

Ref.No.	Parts No.	Description	Q'ty	Remarks
9- 1	1340-241-001-00	BOSS, WHEEL	2	
9- 2	1365-241-002-00	PIN, WHEEL BOSS	4	
9- 3	1305-241-001-00	PIN, HAIR	4	

Fig.10 BONNET and FUEL TANK

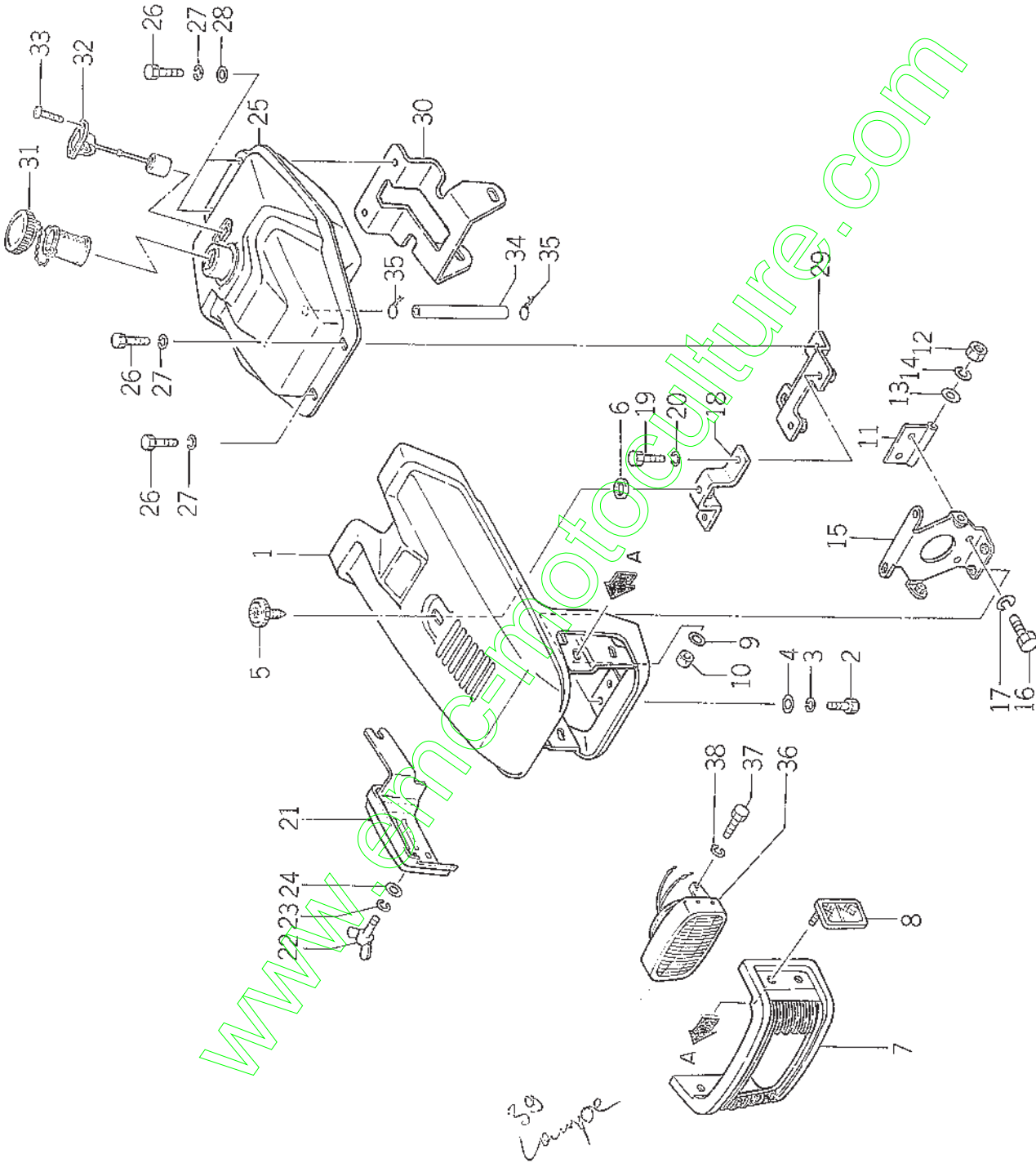

Ref.No.	Parts No.	Description	Q'ty	Remarks
10- 1	1392-601-200-00	BONNET	1	
10- 2	V201-260-801-60	BOLT/M8x16	2	
10- 3	V401-160-008-00	WASHER, SP/M8	2	
10- 4	V413-160-008-00	WASHER/M8	2	
10- 5	1376-601-003-00	KNOB, SET 35	1	
10- 6	1352-601-003-00	SUPPORT	1	
10- 7	1392-601-001-10	GRILLE, FRONT	1	
10- 8	1392-601-002-00	MARKER, SIDE	2	
10- 9	V413-160-005-00	WASHER/M5	4	
10-10	V300-260-005-00	NUT/M5	4	
10-11	1390-601-210-00	STAY, BONNET A	1	
10-12	V300-260-008-00	NUT/M8	1	
10-13	V413-160-008-00	WASHER/M8	1	
10-14	V401-160-008-00	WASHER, SP/M8	1	
10-15	1390-601-220-00	STAY, BONNET B	1	
10-16	V201-260-801-60	BOLT/M8x16	2	
10-17	V401-160-008-00	WASHER, SP/M8	2	
10-18	1392-601-220-00	SUPPORT, BONNET	1	
10-19	V201-260-802-00	BOLT/M8x20	2	
10-20	V401-160-008-00	WASHER, SP/M8	2	
10-21	1390-601-230-00	COVER, SIDE	1	
10-22	V270-160-601-50	BOLT, WING/M6x15	2	
10-23	V401-160-006-00	WASHER, SP/M6	2	
10-24	V413-160-006-00	WASHER/M6	2	
10-25	1392-606-200-00	TANK, FUEL	1	
10-26	V201-260-801-60	BOLT/M8x16	4	
10-27	V401-160-008-00	WASHER, SP/M8	4	
10-28	V413-160-008-00	WASHER/M8	2	
10-29	1390-606-210-00	STAY, TANK A	1	
10-30	1390-606-220-00	STAY, TANK B	1	
10-31	1352-606-200-00	CAP, TANK ASSY	1	
10-32	1392-606-230-00	GAUGE, FUEL ASSY	1	
10-33	V111-165-001-20	SCREW/M5x12	2	
10-34	1390-606-001-00	PIPE, FUEL	1	
10-35	V590-130-909-00	WIRE/0.9x90	2	
10-36	1365-621-200-00	LAMP, HEAD ASSY	1	
10-37	V200-260-601-60	BOLT/M6x16	2	
10-38	V401-160-006-00	WASHER, SP/M6	2	
39	1365 621 20000	Lampe		

Fig.11 MARKS

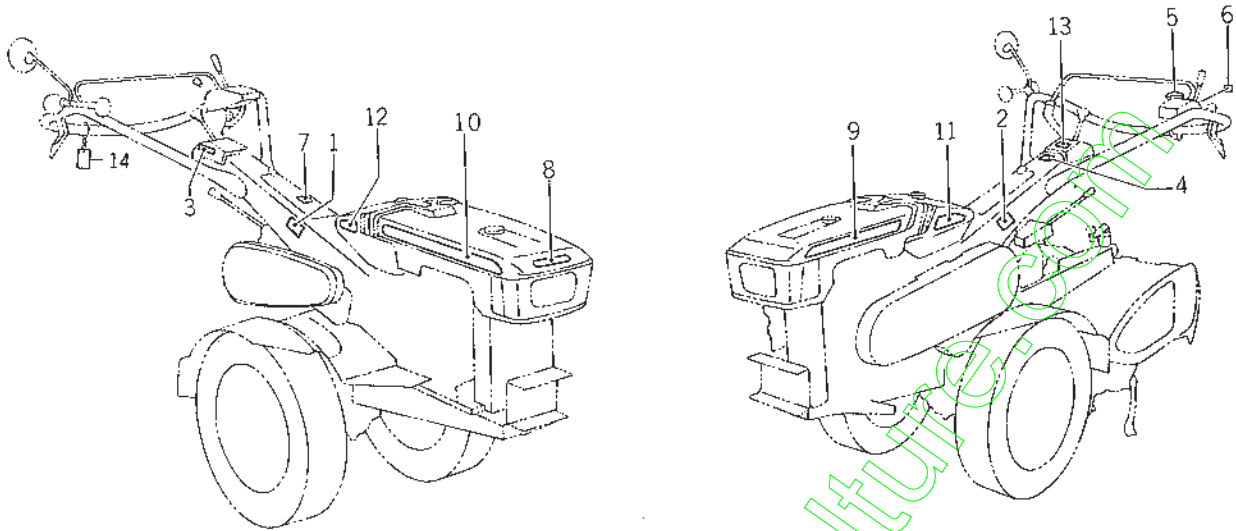

Ref.No.	Parts No.	Description	Q'ty	Remarks
11- 1	1372-952-001-00	MARK, CAUTION A	1	
11- 2	1372-952-002-00	MARK, CAUTION B	1	
11- 3	1370-962-002-00	MARK, STAND	1	
11- 4	1324-957-012-00	MARK/MADE IN JAPAN	1	HANDLE FRAME
11- 5	1392-941-002-00	MARK, CLUTCH	1	CLUTCH BOX
11- 6	1352-952-003-00	MARK, BRAKE	1	CLUTCH BOX
11- 7	1390-942-001-00	MARK, MODEL	1	
11- 8	1386-901-001-00	MARK, HEAT	1	
11- 9	1392-901-003-10	MARK, BONNET L	1	
11-10	1392-901-004-10	MARK, BONNET R	1	
11-11	1390-903-003-10	MARK, SIDE L	1	
11-12	1390-903-004-10	MARK, SIDE R	1	
11-13	1392-901-013-00	MARK, PANEL	1	
11-14	1364-902-009-10	TAG, OIL CAUTION	1	HANDLE PIPE

Fig.12 TOOLS

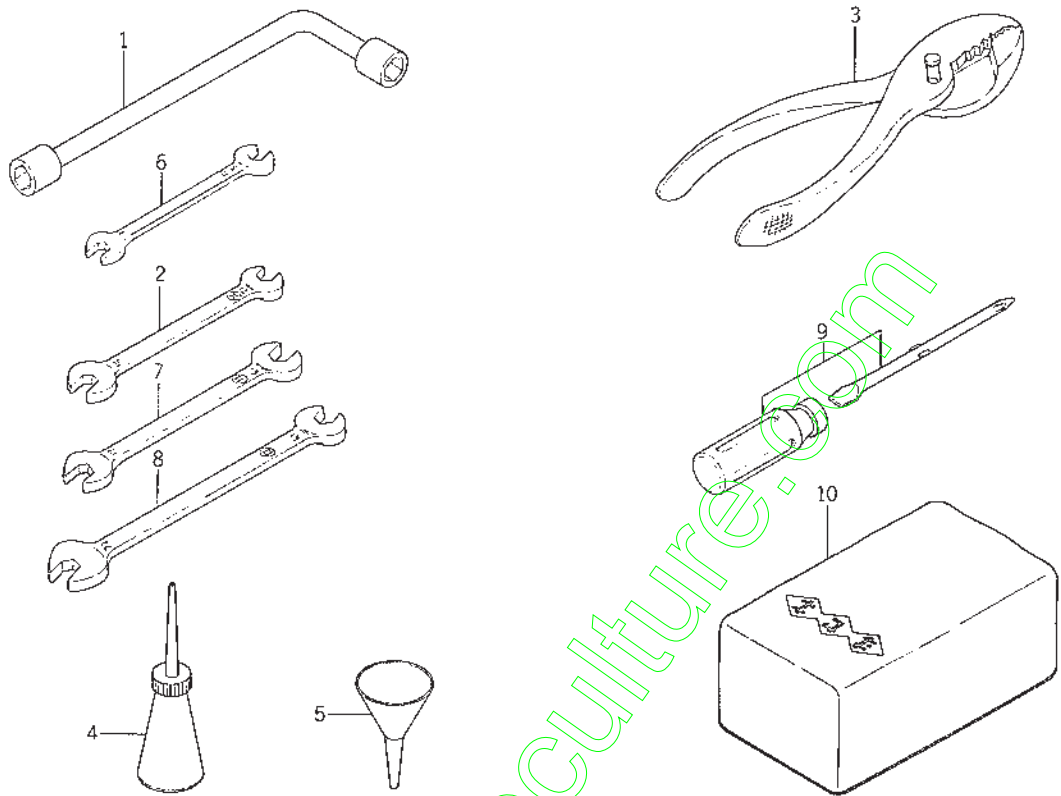

Ref.No.	Parts No.	Description	Q'ty	Remarks
12- 1	1305-906-001-00	SPANNER, BOX/L	1	
12- 2	V920-551-201-40	SPANNER/12-14	1	
12- 3	V936-250-015-00	PLIERS/150	1	
12- 4	1352-906-001-00	OILER	1	
12- 5	1352-906-002-00	FUNNEL	1	
12- 6	V920-550-801-00	SPANNER/8-10	1	
12- 7	V920-551-301-70	SPANNER/13-17	1	
12- 8	V920-551-902-20	SPANNER/19-22	1	
12- 9	1381-906-001-00	DRIVER	1	
12-10	1351-906-003-00	COVER, SHEET	1	

NUMERICAL INDEX

www.emc-motoculture.com

www.emc-motoculture.com

NUMERICAL PARTS INDEX

ENGINE

Parts Code	Ref No.	Parts Code	Ref No.	Parts Code	Ref No.
5110-R06-10X-XX	24	5145-966-143-AX	C-1-25	5158-002-111-AX	34
5112-B06-30X-XX	77	5145-986-138-AX	C-1-14	5158-011-181-AX	3
5114-096-812-00	63	5145-986-157-AX	C-1-11	5158-011-231-AX	7
5122-113-454-00	R-1-13	5151-927-432-00	116	5158-011-233-AX	9
5127-506-116-00	C-1-7	5153-533-455-00	R-1-14	5158-011-310-AX	12
5130-B06-12X-XX	11, 75, 134	5154-707-214-AX	55, 118	5158-011-311-AX	A-1-1
5130-B06-16X-XX	95	5154-707-441-AX	54, 117	5158-011-312-AX	A-1-3
5130-B08-28X-XX	103	5154-830-851-BX	140	5158-011-313-AX	A-1-4
5130-B08-35X-XX	104	5156-013-482-AX	131	5158-011-327-AX	A-1-2
5130-G10-45X-XX	5	5156-216-561-CX	66	5158-011-388-AX	13
5131-226-116-00	C-1-28	5157-011-111-AX	1	5158-011-482-AX	74
5136-2A8-168-00	125	5157-011-121-AX	2	5158-012-112-AX	35
5136-502-371-00	50, 219	5157-013-010-AX	45	5158-012-113-AX	36
5136-506-112-00	C-1-4	5157-013-111-AX	44	5158-012-116-AX	37
5136-506-114-00	C-1-5	5157-211-181-AX	4	5158-012-121-AX	38
5136-506-128-00	C-1-23	5157-211-400-AX	16	5158-012-211-AX	39
5136-506-134-00	C-1-13	5157-211-431-AX	17	5158-012-310-AX	40
5136-506-510-02	65	5157-211-432-AX	18	5158-013-121-AX	46
5136-506-512-00	F-1-2	5157-211-433-AX	21	5158-013-122-AX	47
5136-506-517-00	F-1-1	5157-211-434-AX	22	5158-013-217-AX	49
5136-506-518-00	F-1-4	5157-211-445-AX	23	5158-013-240-BX	51
5136-506-519-00	F-1-3	5157-211-531-AX	14	5158-013-245-AX	52
5136-506-522-00	F-1-6	5157-211-611-AX	71	5158-014-124-CX	99
5136-506-527-00	67	5157-211-631-AX	72	5158-014-231-AX	56
5136-796-812-00	70	5157-213-210-AX	48	5158-014-235-AX	100
5144-011-341-AX	15	5157-213-430-AX	138	5158-015-110-AX	107
5144-015-121-BX	108	5157-213-432-AX	R-1-1	5158-015-122-AX	111
5144-015-135-AX	113	5157-213-453-AX	R-1-12	5158-015-147-AX	109
5144-015-383-AX	87, 88	5157-214-110-BX	53	5158-015-210-AX	76
5144-015-388-AX	89	5157-216-100-AX	59	5158-015-231-BX	80
5144-053-092-AX	110	5157-216-102-AX	C-1-12	5158-015-232-BX	81
5144-996-127-AX	C-1-22	5157-216-113-AX	C-1-15	5158-015-310-AX	82
5144-996-159-AX	C-1-26	5157-216-113-AX	C-1-15	5158-015-314-AX	83
		5157-216-129-AX	C-1-18	5158-015-317-BX	84
		5157-216-134-AX	C-1-17	5158-015-321-AX	90
		5157-216-142-AX	C-1-8	5158-015-335-AX	85
		5157-216-155-AX	C-1-19	5158-015-337-AX	86
				5158-016-126-AX	C-1-21
				5158-016-132-AX	C-1-20
				5158-016-181-AX	60
				5158-016-184-AX	61
				5158-016-732-AX	126

Parts Code	Ref No.	Parts Code	Ref No.	Parts Code	Ref No.
5158-017-411-AX	115	5180-B06-12X-XX	19	5702-A04-100-0X	69
5158-018-103-AX	120	5180-B06-25X-XX	127		
5158-018-111-BX	119	5180-B06-30X-XX	128		
5158-018-124-AX	121				
5158-018-164-AX	123	5183-B08-25X-XX	42		
5158-018-165-AX	124				
5158-018-465-BX	122	5187-B06-67X-XX	139		
5158-211-632-BX	73				
5158-218-410-AX	135	5188-633-452-00	R-1-11		
5158-224-120-AX	98				
5158-226-133-AX	C-1-27	5214-B05-16A-XX	96		
5158-226-852-AX	62				
5158-228-161-AX	132	5311-B06-00X-XX	78, R-1-2		
5158-235-382-AX	92				
5158-236-115-AX	C-1-6	5312-B05-00A-XX	97		
5158-236-122-AX	C-1-16				
5158-236-130-AX	C-1-24	5314-B10-00X-XX	25		
5158-236-139-AX	C-1-1	5314-B14-00A-XX	130		
5158-254-165-AX	101				
5158-256-103-AX	C-1-10	5317-R08-00X-XX	32		
5164-203-442-BX	R-1-4	5322-015-351-00	93		
5164-203-445-BX	R-1-9	5322-015-352-00	94		
5164-203-446-AX	R-1-8				
5164-203-449-BX	R-1-6	5410-B06-00X-XX	114		
5164-513-441-AX	R-1-10	5410-B08-00X-XX	102		
5164-513-456-AX	R-1-5	5410-B10-00X-XX	6		
5164-703-448-AX	R-1-7				
5164-701-232-00	8	5411-B06-00X-XX	20, 26, 79, 27		
5164-701-442-00	30				
5164-913-274-00	41	5461-F06-00A-XX	28, R-1-3		
		5461-F08-00X-XX	33		
5165-506-137-AX	C-1-3	5461-F10-00A-XX	29		
5166-706-101-AX	C-1-2	5463-H10-00X-XX	68		
5166-708-161-00	133				
5166-715-381-AX	91	5511-A07-35X-XX	43		
5171-G08-18X-XX	31	5551-A08-16X-XX	105		
5172-708-418-BX	136	5554-A06-00X-XX	112		
5172-708-419-AX	137				
5172-906-141-00	C-1-9	5601-A62-06X-XX	57, 106		

Parts Code	Ref No.	Parts Code	Ref No.	Parts Code	Ref No.
1302-225-003-00	4-2, 4-7	1352-219-100-00	3-8	1352-600-052-00	6-20
		1352-222-001-00	3-13	1352-601-003-00	10-6
1305-241-001-00	9-3	1352-222-002-00	3-14	1352-606-200-00	10-31
1305-906-001-00	12-1	1352-224-002-00	3-20	1352-616-001-00	1-9
1305-931-003-00	1-31, 2-21	1352-224-004-00	3-22	1352-616-002-00	1-10, 1-17
		1352-229-001-00	4-1	1352-616-003-00	1-21
1310-225-005-00	3-25	1352-229-002-00	4-4	1352-621-001-00	6-48, 8-50
		1352-229-003-10	4-6	1352-621-003-00	6-21
1317-201-004-00	5-8	1352-229-004-00	4-9	1352-621-004-00	6-22
1317-406-002-00	8-34	1352-229-005-00	4-11	1352-906-001-00	12-4
1317-621-002-00	6-47	1352-229-006-00	4-18	1352-906-002-00	12-5
		1352-229-007-00	4-20	1352-917-001-00	3-34
1324-205-002-00	3-35, 3-46, 5-9, 5-23,	1352-229-100-00	4-14	1352-917-002-00	3-42
1324-353-004-00	7-14	1352-301-001-00	6-10	1352-917-003-00	3-38
1324-353-005-00	7-15	1352-301-002-00	6-11	1352-917-004-00	3-41
1324-957-012-00	11-4	1352-311-100-00	6-13	1352-917-005-00	3-45
		1352-400-051-00	8-33-1	1352-931-001-00	1-26
		1352-400-052-00	8-32-1	1352-931-002-00	1-27
1340-217-004-00	3-5, 3-12	1352-402-001-00	8-58	1352-952-003-00	11-6
1340-241-001-00	9-1	1352-403-001-10	8-26		
		1352-403-002-00	8-29	3563-102-002-00	8-25
1343-216-002-00	2-30	1352-403-003-00	8-31		
1343-216-003-00	2-31	1352-404-004-00	8-10	1365-202-002-00	5-15
		1352-404-005-00	8-11	1365-216-001-30	2-1
1351-906-003-00	12-10	1352-404-007-00	8-16	1365-216-002-30	2-4
		1352-404-009-00	8-18	1365-216-003-00	2-13
1352-006-100-00	1-7	1352-404-010-00	8-19	1365-216-004-00	2-22
1352-106-001-00	1-32	1352-404-200-10	8-1	1365-216-005-00	2-3
1352-106-002-00	1-8	1352-404-300-10	8-51	1365-224-001-00	3-16
1352-161-004-00	1-22	1352-404-400-20	8-52	1365-224-002-00	3-19
1352-201-202-00	5-4	1352-404-600-20	8-15	1365-224-003-00	3-21
1352-202-001-00	5-14	1352-404-800-00	8-21	1365-225-001-00	3-27
1352-202-300-00	5-49	1352-405-100-00	8-7	1365-225-100-00	3-24
1352-209-001-00	5-21	1352-406-002-00	8-36	1365-229-001-00	4-16
1352-209-002-00	5-22	1352-406-003-00	8-37	1365-241-002-00	9-2
1352-209-003-10	5-27	1352-406-004-00	8-38	1365-301-200-10	6-7
1352-209-004-00	5-28	1352-406-200-00	8-32	1365-600-051-20	6-46
1352-209-005-10	5-31	1352-406-210-00	8-33	1365-611-001-00	5-51
1352-209-100-00	5-26	1352-416-001-10	8-45	1365-611-002-00	5-52
1352-216-004-00	2-9	1352-416-002-10	8-46	1365-616-200-00	1-16
1352-217-002-00	3-4	1352-416-003-00	8-49	1365-616-300-00	1-20
1352-217-003-00	3-6	1352-416-100-20	8-40	1365-621-200-00	10-36
1352-217-004-00	3-7	1352-416-200-00	8-44		

Parts Code	Ref No.	Parts Code	Ref No.	Parts Code	Ref No.
1366-651-002-00	6-23	1390-201-003-10	5-3	1392-616-200-00	1-40
		1390-201-004-00	5-12	1392-621-001-00	6-49
1368-301-100-40	6-1	1390-203-200-00	5-44	1392-901-003-10	11-9
		1390-203-220-00	5-45	1392-901-004-10	11-10
1370-962-002-00	11-3	1390-217-001-00	3-1	1392-901-013-00	11-13
		1390-219-001-00	3-9	1392-941-002-00	11-5
1372-121-215-00	6-51	1390-226-001-00	3-29		
1372-351-000-00	7-0-1	1390-226-002-00	3-31	1414-117-004-00	8-41
1372-351-001-00	7-8	1390-226-200-00	3-28		
1372-351-002-00	7-9	1390-601-210-00	10-11	1421-621-038-00	7-28
1372-351-003-10	7-13	1390-601-220-00	10-15		
1372-351-004-00	7-18	1390-601-230-00	10-21	1426-621-018-00	8-55
1372-351-005-00	7-23	1390-606-001-00	10-34		
1372-351-200-10	7-1	1390-606-210-00	10-29	1427-621-026-00	7-26
1372-351-210-00	7-2	1390-606-220-00	10-30		
1372-351-220-00	7-27	1390-612-200-00	5-37	1703-101-020-00	4-17
1372-401-001-10	8-5	1390-612-210-00	5-42		
1372-401-002-00	8-17	1390-612-220-00	5-54	2101-230-001-00	8-53
1372-402-001-00	8-23	1390-903-003-10	11-11		
1372-406-001-00	8-35	1390-903-004-10	11-12	3746-172-013-00	6-50
1372-451-200-10	8-24	1390-930-200-10	2-16		
1372-952-001-00	11-1	1390-931-200-00	1-30, 2-20	7954-205-101-00	2-12
1372-952-002-00	11-2	1390-942-001-00	11-7		
				8057-006-000-00	2-25
1376-402-003-00	7-25	1392-101-200-00	1-1	8057-006-002-00	2-26
1376-601-003-00	10-5	1392-121-001-00	1-35	8057-006-003-00	2-27
		1392-204-200-00	5-18		
1380-401-003-00	8-6	1392-301-001-00	6-42	V111-165-001-00	6-8
		1392-301-002-00	8-59	V111-165-001-20	10-33
1381-906-001-00	12-9	1392-301-003-00	6-43	V111-165-002-50	6-52
		1392-301-005-00	6-45	V111-166-001-00	5-53
1385-202-001-00	5-46	1392-301-200-00	6-38	V111-166-001-40	6-39, 8-60
		1392-401-001-00	8-2		
1386-622-200-00	6-0-1	1392-401-200-00	6-16	V200-160-601-20	1-23
1386-622-201-00	6-27	1392-401-210-10	8-54	V200-260-601-00	2-23
1386-622-202-00	6-29	1392-601-001-10	10-7	V200-260-601-20	2-14, 3-32,
1386-622-203-00	6-31	1392-601-002-00	10-8		4-12, 5-32
1386-622-204-00	6-30	1392-601-200-00	10-1	V200-260-601-60	2-10, 10-37
1386-622-205-00	6-33	1392-601-220-00	10-18	V200-260-603-50	7-21
1386-901-001-00	11-8	1392-606-200-00	10-25		
		1392-606-230-00	10-32	V201-260-801-60	5-19, 5-41,
1390-201-001-10	5-1	1392-611-001-00	5-36		5-55, 6-17,
1390-201-002-00	5-2	1392-611-200-00	5-35		7-19, 10-2,

Parts Code	Ref No.	Parts Code	Ref No.	Parts Code	Ref No.
V201-260-801-60	10-16, 10-26	V401-160-008-00	1-14, 1-19,	V500-153-001-80	8-39
V201-260-802-00	1-41, 3-36,		3-37, 3-40,	V500-153-002-00	7-17
	3-39, 3-47,		3-44, 3-48,	V500-154-003-50	7-12
	5-11, 5-24,		5-6, 5-10,	V500-162-001-50	8-48
	10-19		5-20, 5-25,		
V201-260-802-50	2-5		5-39, 5-56,	V580-140-301-50	8-22
V201-260-803-50	2-8, 3-43,		6-18, 7-20,	V580-140-301-80	6-12
	5-5		8-13, 10-3	V580-140-402-20	8-3, 8-42
V201-260-807-50	8-12		10-14, 10-17,	V580-140-502-80	8-27
V201-260-808-08	1-12		10-20, 10-27		
V201-261-004-50	1-36	V401-160-010-00	1-37, 7-6	V590-102-007-00	8-43
V201-261-005-00	6-24	V401-160-012-00	1-4, 1-29,	V590-130-908-00	8-28
V201-261-012-00	6-2		2-18, 5-16,	V590-130-909-00	10-35
V201-261-012-50	6-3		7-4	V590-130-910-00	8-4
V201-261-206-00	1-28	V401-160-016-00	7-11		
V201-461-002-50	7-5	V401-260-006-00	2-11, 2-15,	V600-110-620-20	3-10
V201-461-204-50	6-14, 7-3		2-24, 4-13,	V600-110-620-30	3-15
V201-461-207-50	1-2, 2-17		5-34, 6-35	V600-110-620-80	3-26
		V401-260-008-00	2-6, 6-36	V600-110-630-40	3-2, 3-17
V270-160-601-50	10-22	V401-260-010-00	5-30, 6-5,	V600-116-204-50	3-3, 3-11
			6-25, 6-37	V600-150-630-20	5-47
V300-260-005-00	10-10, 6-53	V401-260-012-00	6-15		
V300-260-006-00	1-24, 6-34	V410-160-008-00	8-47	V680-200-001-00	4-3, 4-8
V300-260-008-00	1-13, 2-7,	V411-160-005-00	6-44	V704-140-015-00	5-50
	5-7, 5-43,	V411-160-006-00	1-25	V704-140-020-00	3-18
	6-19, 6-32,	V411-160-012-00	8-56		
	8-14, 10-12			V705-140-035-00	3-23
V300-260-010-00	1-6, 1-38,	V413-160-005-00	12-9	V705-140-042-00	5-48
	6-6, 6-26,	V413-160-006-00	5-33, 6-41,		
	6-28		8-62, 10-24	V710-140-010-00	8-57
V300-260-012-00	1-3, 2-19,	V413-160-008-00	1-15, 5-38,		
	2-29, 5-17		8-8, 10-4,	V720-101-900-90	4-5, 4-10
V321-260-016-00	7-10		10-13, 10-28	V720-101-901-00	4-21
V340-160-008-00	5-40	V413-160-010-00	1-33, 1-39,	V720-102-401-00	3-30, 4-19
			5-29, 6-4,	V720-102-401-60	4-15
			7-7, 8-63		
V371-160-008-00	1-18	V413-160-012-00	7-16	V781-300-000-60	2-2
V401-160-005-00	6-9	V500-151-601-20	8-30	V817-200-040-00	5-13
V401-160-006-00	3-33, 6-40,	V500-152-001-40	8-9, 8-20		
	7-22, 8-61,	V500-152-501-50	7-24	V920-550-801-00	12-6
	10-23, 10-38	V500-152-502-00	1-34	V920-551-201-40	12-2
		V500-153-001-50	1-11		

Parts Code	Ref No.	Parts Code	Ref No.	Parts Code	Ref No.
V920-551-301-70	12-7				
V920-551-902-20	12-8				
V936-250-015-00	12-3				
W201-261-003-50	1-5				
W201-261-204-00	2-28				

www.emc-motoculture.com

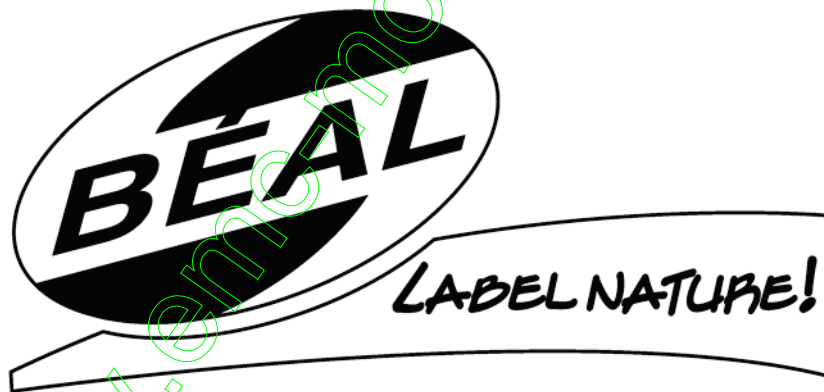

**Yvan Béal - 21, av. de l'Agriculture - B.P 16
Z.I. du Brézet - 63014 Clermont-Ferrand Cedex 2
Tél: 04 73 91 93 51 - Télécopie : 04 73 90 23 11
www.yvanbeal.fr - E-mail : info@yvanbeal.fr
R.C.S. B 304 973 886 - S.A.S. au capital de 612 000 €**