

ILLUSTRATED PARTS BREAKDOWN

**HUSQVARNA
10 HP LAWN RIDER
MODEL NO. H1036A
954 00 03-12**

LT100

www.emc-motoculture.com

ILLUSTRATED PARTS BREAKDOWN

ELECTRICAL

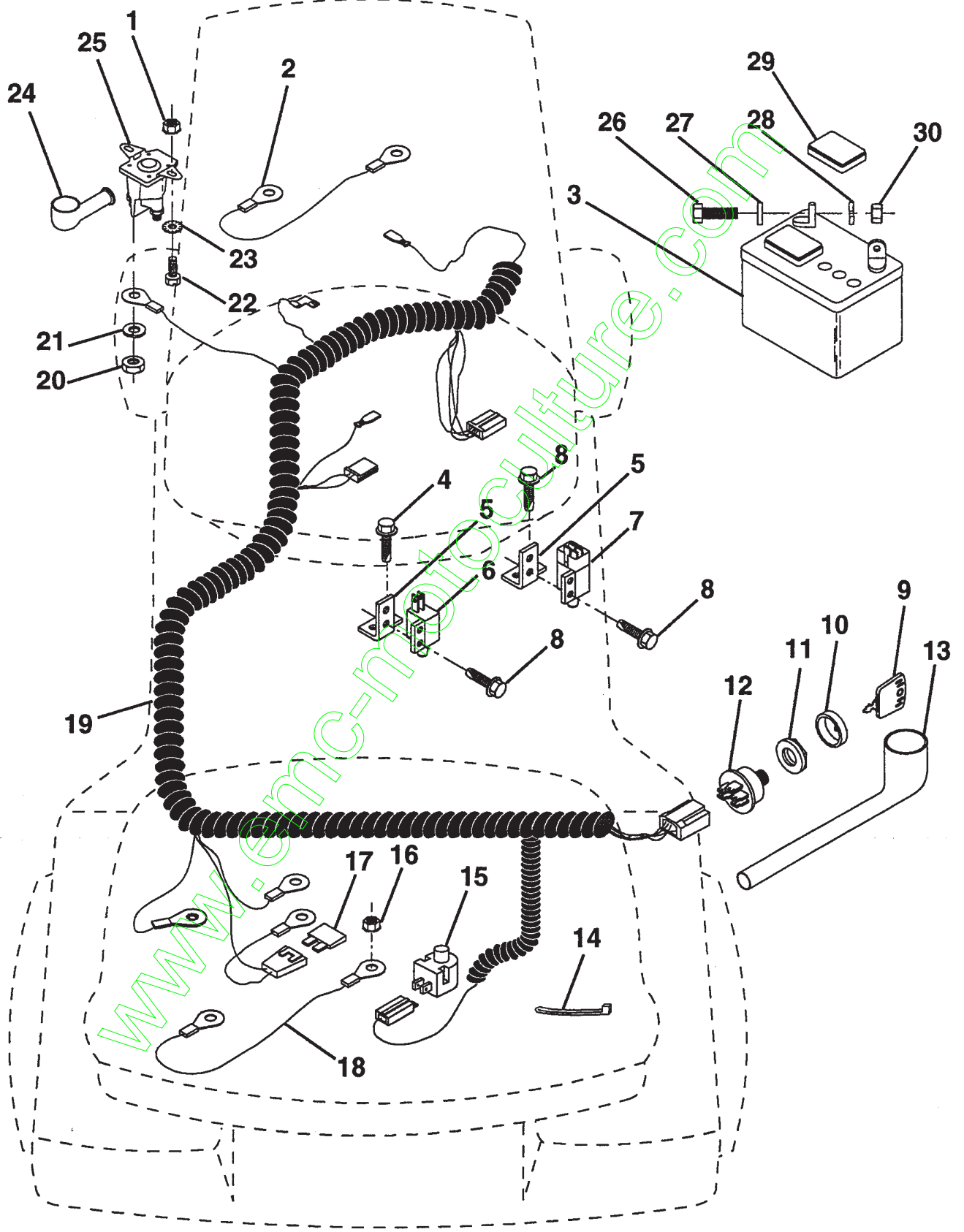

ILLUSTRATED PARTS BREAKDOWN

ELECTRICAL

KEY NO.	PART NO.	DESCRIPTION	KEY NO.	PART NO.	DESCRIPTION
1	873510400	Nut, Hex Keps 1/4-20	17	532108824	Fuse
2	532131562	Assembly, Cable	18	532000596	Assembly, Cable
3	532121265	Battery	19	532132223	Harness, Ignition
4	817211008	Screw, Hex Wsh. Tap #10-16 x 1/2	20	873350400	Nut, Hex Jam 1/4-20
5	532108236	Bracket, Switch	21	810090400	Washer, Lock 1/4
6	532104445	Switch, Interlock	22	874780408	Bolt, Fin Hex 1/4-20 UNC x 1/2 Gr. 5
7	532109553	Switch, Interlock	23	811050400	Washer, Lock Ext. Tooth 1/4
8	817021008	Screw, Hex Hd. Tap #10-24 x 1/2	24	532124783	Cover, Terminal
9	532122147	Key, Molded	25	532109081	Solenoid
10	532123620	Cover, Key Ignition	26	874760412	Bolt, Hex Hd. 1/4-20 UNC x 3/4
11	532124211	Nut, Ignition	27	819091016	Washer 9/32 x 5/8 x 16
12	532125104	Switch, Ignition	28	810040400	Washer, Lock 1/4
13	532124083	Cover, Ignition Switch	29	532121264	Cap, Battery
14	532124756	Tie, Cable	30	873220400	Nut, Fin Hex 1/4-20 UNC
15	532121305	Switch, Plunger			
16	873510500	Nut, Hex, Keps 5/16-18			

NOTE: All component dimensions given in U.S. inches
1 inch = 25.4 mm

HARDWARE SHOWN LARGER FOR EASIER IDENTIFICATION

www.emc-motocult.com

ILLUSTRATED PARTS BREAKDOWN

FENDER / CHASSIS

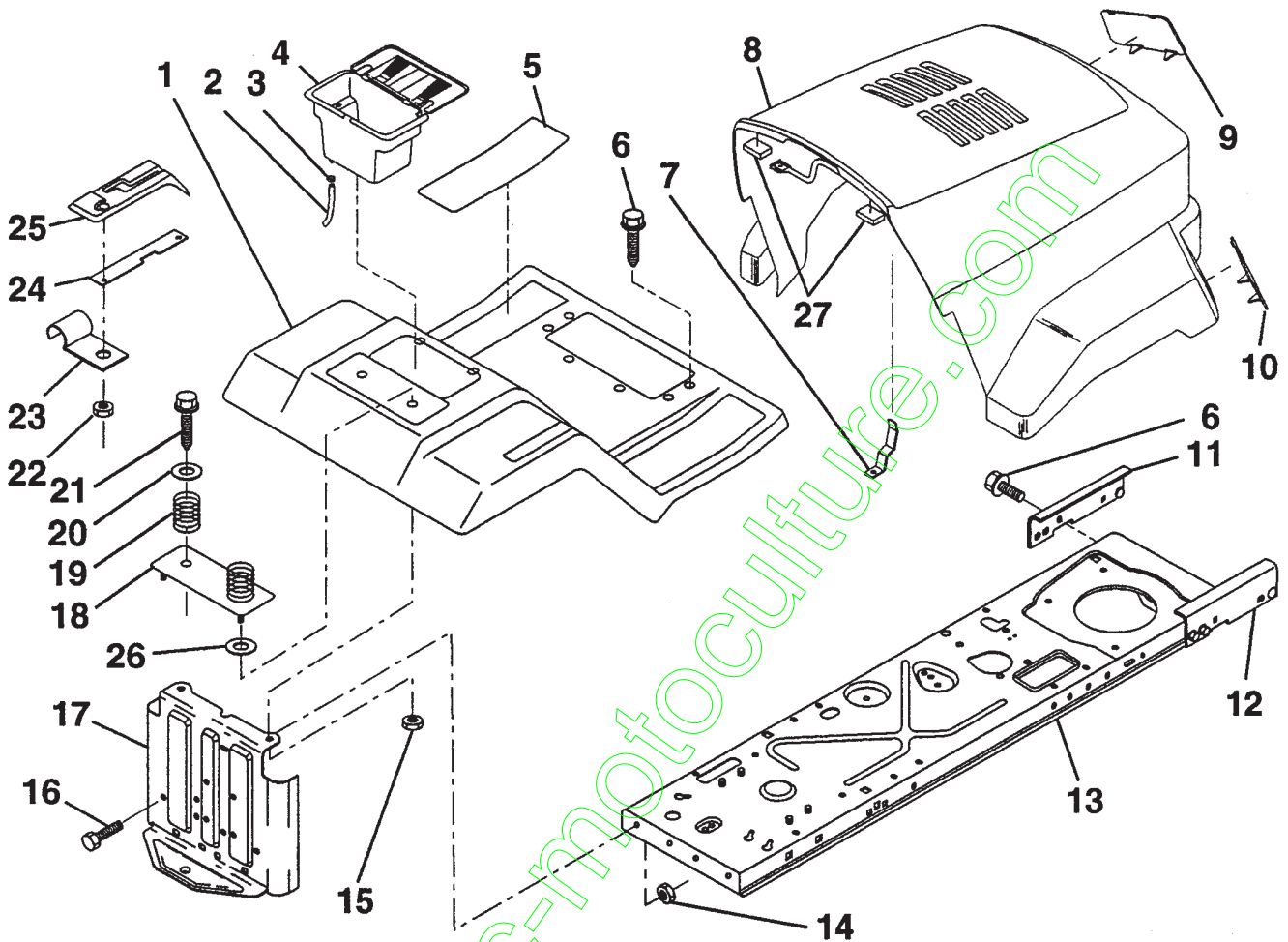

KEY NO.	PART NO.	DESCRIPTION	KEY NO.	PART NO.	DESCRIPTION
1	532125141	Fender/Footrest	14	873680500	Nut, Crownlock 5/16-18
2	532105687	Tube, Battery Drain	15	873680400	Nut, Crownlock 1/4-20 UNC
3	532109596	Clamp, Hose	16	874760512	Bolt, Hex Hd. 5/16-18 UNC x 3/4
4	532129965	Case, Battery	17	532127880	Drawbar
5	532124144	Pad, Footrest	18	532125142	Plate, Asm. Battery
6	817490512	Screw, Hex Wsh. Thrdol. 5/16-18 x 3/4	19	532124181	Spring, Compression, Seat
7	532131318	Latch, Hood	20	819132012	Washer 13/32 x 1-1/4 x 12 Ga.
8	532131053	Hood/Grill Asm. (Includes Key Nos. 21 and 22)	21	817490612	Bolt, Hex 3/8-16 Tapping
9	532130986	Lens, L.H.	22	532124346	Nut, Self-Threading, Washer Head 3/16
10	532130985	Lens, R.H.	23	532126470	Clip, Insulated
11	532128449	Bracket, Asm. Pivot Frame, L.H.	24	532124602	Bar, Shift Lock
12	532128808	Bracket, Asm. Pivot Frame, R.H.	25	532126996	Console, Shift Control
13	532123645	Assembly, Frame	26	819091413	Washer 9/32 x 7/8 x 13 Ga.
			27	532126938	Bumper, Hood
			--	532131319	Cover, Light Socket Hole

HARDWARE SHOWN LARGER FOR EASIER IDENTIFICATION

ILLUSTRATED PARTS BREAKDOWN

SEAT

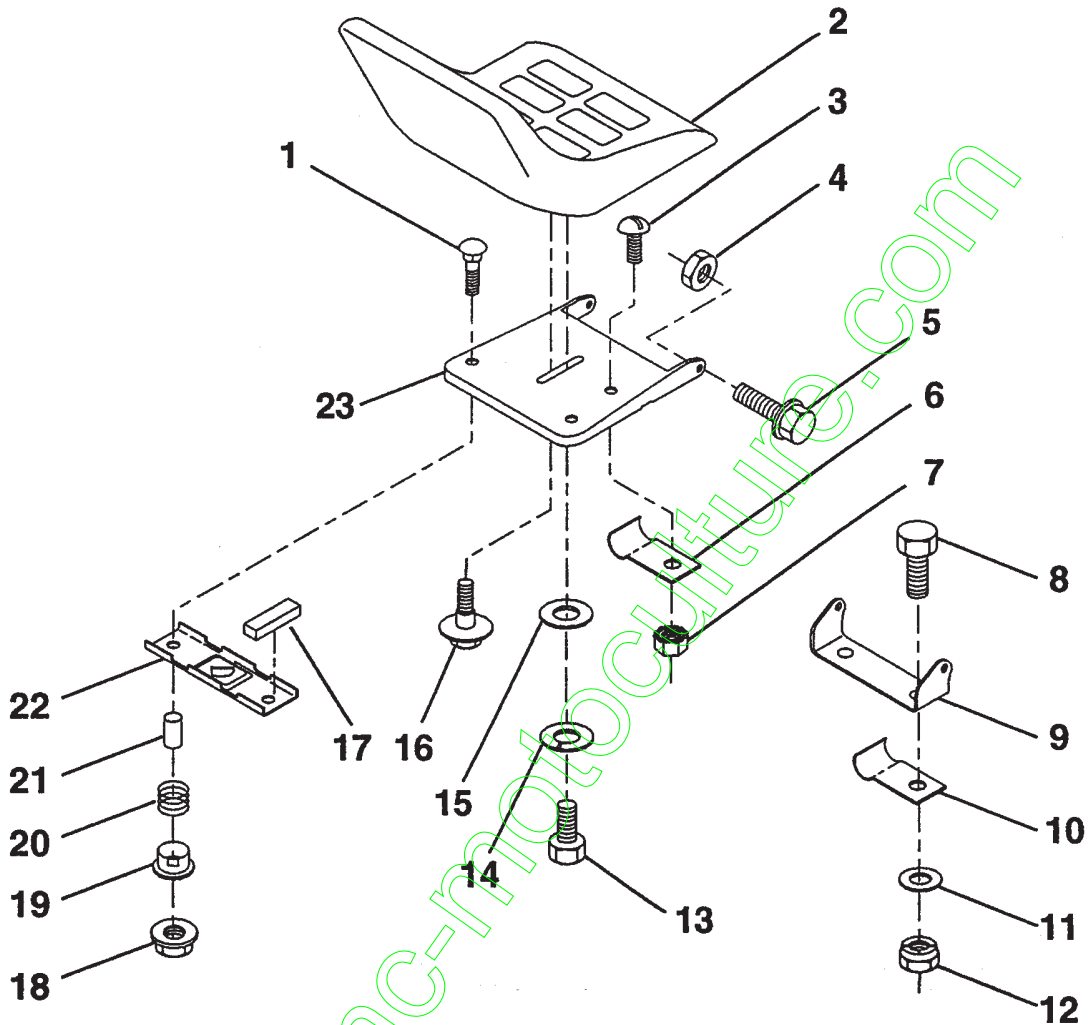

KEY NO.	PART NO.	DESCRIPTION
1	872170410	Bolt, Carriage 1/4-20 x 1-1/4
2	532130875	Seat
3	874641008	Screw, Slotted Pan Head #10-32 x 1/2
4	873680500	Nut, Crownlock 5/16-18
5	532105529	Bolt, Shoulder 5/16-18 UNC
6	532124967	Clip, Insulated
7	873951000	Nut, Keps #10-32 UNF
8	874760612	Bolt, Fin Hex 3/8-16 UNC x 3/4
9	532126656	Bracket, Pivot Seat
10	532126471	Clip, Insulated
11	819131210	Washer 12/32 x 3/4 x 10 Ga.
12	873680600	Nut, Crownlock 3/8-16 UNC

KEY NO.	PART NO.	DESCRIPTION
13	874780814	Bolt, Fin Hex 1/2-13 UNC x 7/8 Gr. 5
14	810040800	Washer, Lock Hvy Helical Spring
15	819171912	Washer, 17/32 x 1-3/16 x 12 Ga.
16	532127018	Bolt, Shoulder
17	532121251	Strip, Foam
18	532123976	Nut, Hex Large Flange Lock
19	532121248	Bushing, Snap
20	532121250	Spring, Compression
21	532121249	Spacer, Split 28 Id. x .88 Lg.
22	532121246	Bracket, Switch, Mounting
23	532124294	Pan, Seat

HARDWARE SHOWN LARGER FOR EASIER IDENTIFICATION

ILLUSTRATED PARTS BREAKDOWN

DASH

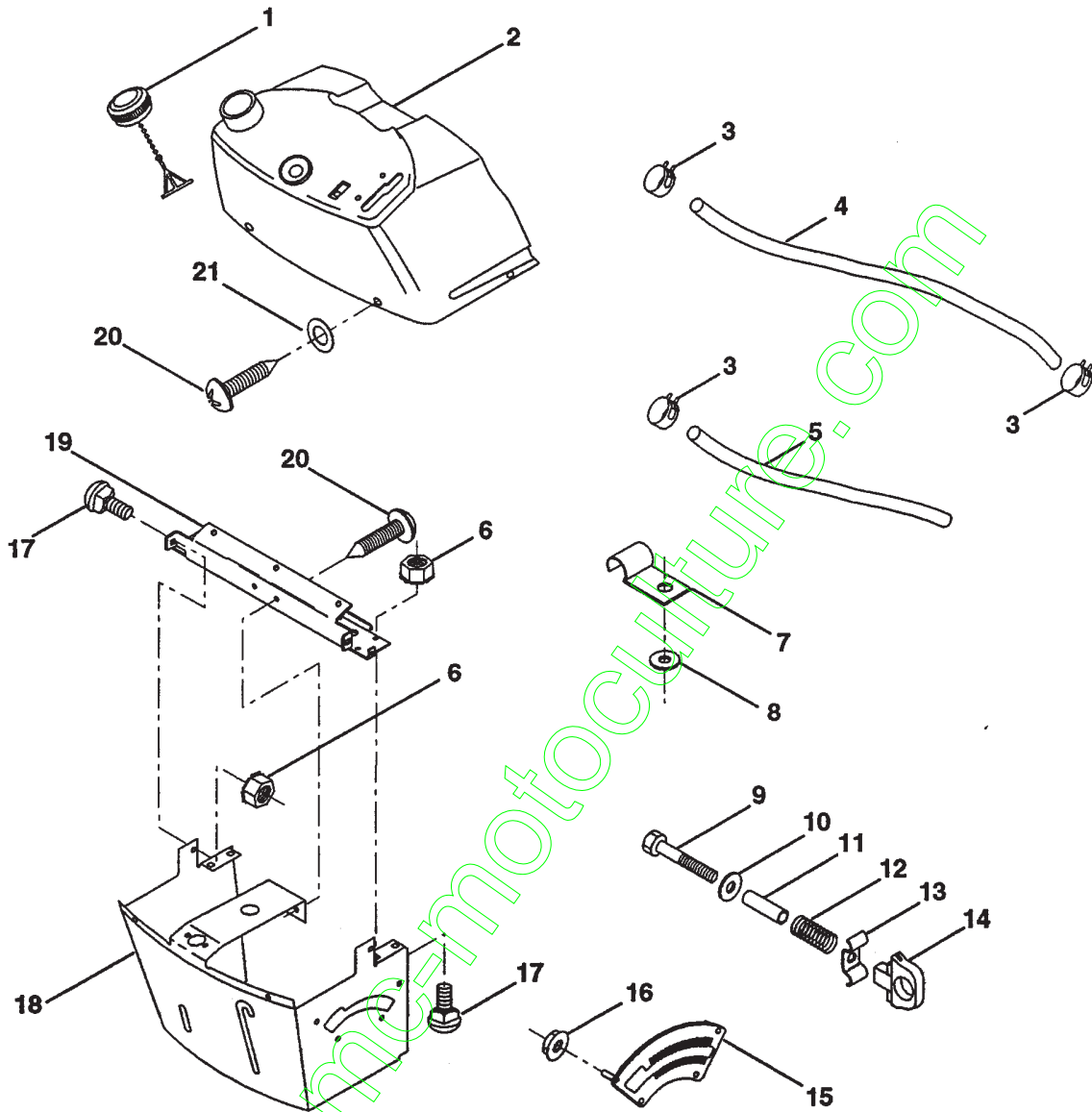

KEY NO.	PART NO.	DESCRIPTION
1	532127399	Cap, Fuel
2	532130915	Assembly, Dash & Fuel Tank
3	532123487	Clamp, Hose
4	532008544	Line, Fuel
5	532008548	Line, Fuel
6	873510400	Nut, Hex, Keps 1/4-20
7	532124996	Clip, Fuel Line
8	819091216	Washer 9/32 x 3/4 x 16 Ga.
9	874760428	Bolt, Hex, Fin 1/4-20 x 1-3/4
10	819091413	Washer 11/32 x 11/16 x 16 Ga.
11	532121249	Spacer, Split

KEY NO.	PART NO.	DESCRIPTION
12	532003720	Spring
13	532126450	Clip, Height Adjustment
14	532126115	Knob, Height Stop
15	532122023	Adjustment, Quadrant Height
16	532124346	Nut, Self-Threading 3/16-18
17	872110404	Bolt, Carriage 1/4-20 x 1/2 Gr. 5
18	532130745	Support Assembly, Dash
19	532130722	Brace, Cross
20	532130052	Screw, Self-Tapping 1/4-20 x 1/2
21	819090816	Washer 9/32 x 1/2 x 16 Ga.

HARDWARE SHOWN LARGER FOR EASIER IDENTIFICATION

ILLUSTRATED PARTS BREAKDOWN

STEERING WHEEL

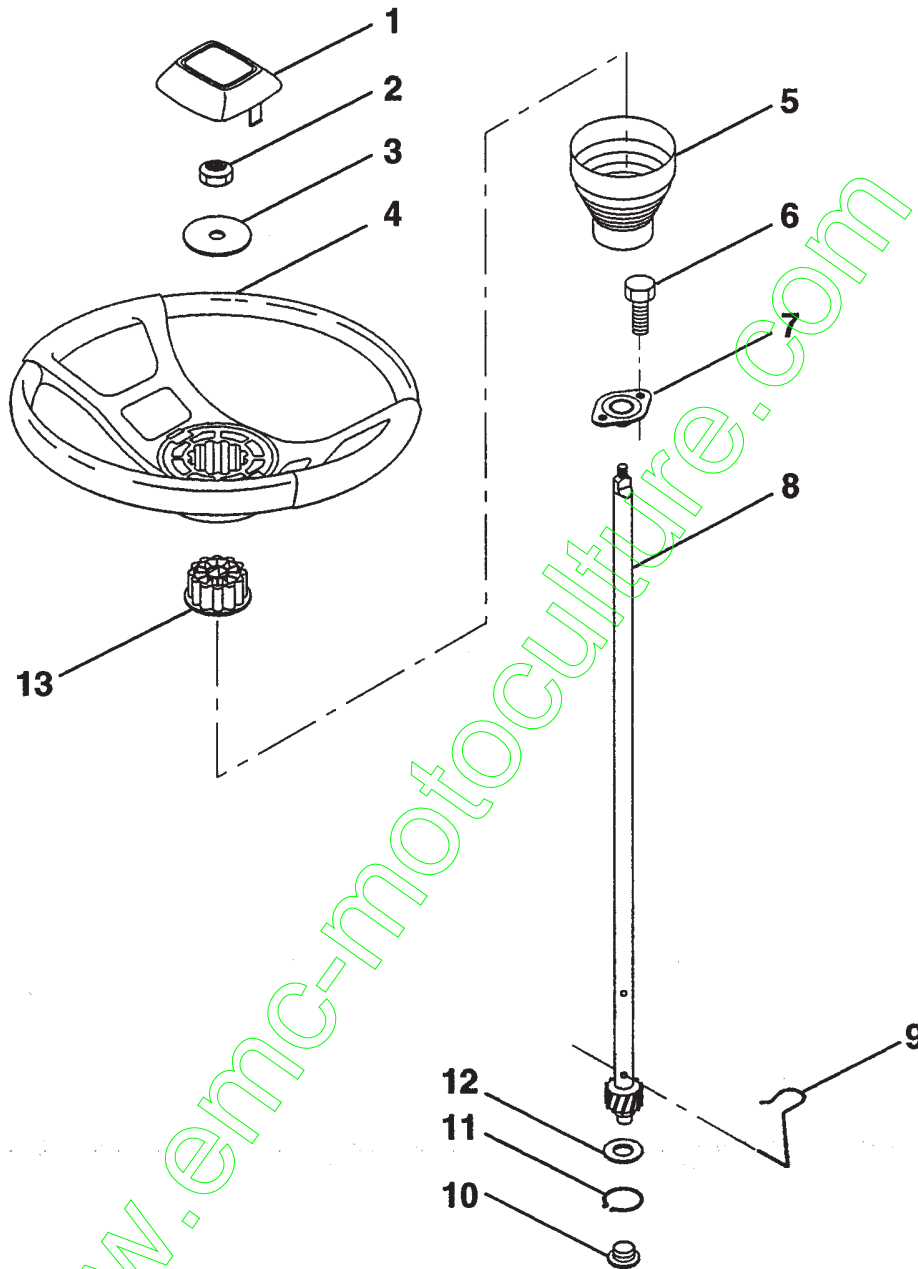

KEY NO.	PART NO.	DESCRIPTION
1	532124416	Insert, Wheel, Steering
2	532124701	Locknut 3/8-24 UNF
3	819133808	Washer 12/32 x 2-3/8 x 8 Ga.
4	532124415	Wheel, Steering
5	532127396	Sleeve, Steering
6	817431008	Screw, Hex #10-16 x 1/2 TY-B
7	532102803	Bushing, Steering

KEY NO.	PART NO.	DESCRIPTION
8	532123651	Shaft, Steering
9	532124210	Clip, Steering
10	532123438	Bushing, Lower, Steering
11	812000045	Ring, Retaining
12	819211616	Washer 21/32 x 1 x 16 Ga.
13	532104820	Adaptor, Wheel, Steering

HARDWARE SHOWN LARGER FOR EASIER IDENTIFICATION

ILLUSTRATED PARTS BREAKDOWN

SECTOR GEAR / AXLE SUPPORT

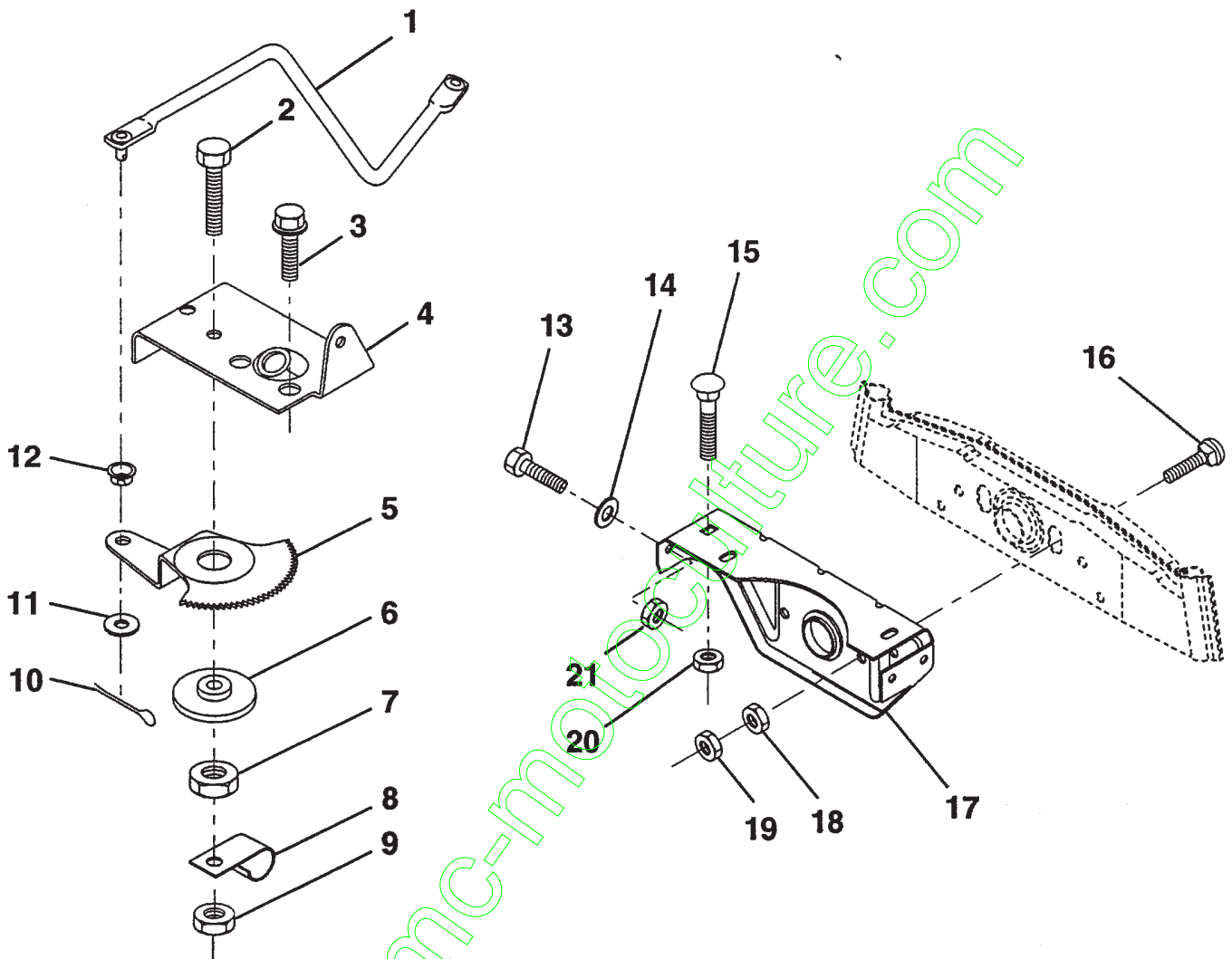

KEY NO.	PART NO.	DESCRIPTION
1	532124093	Link, Drag
2	874780828	Bolt, Fin Hex 1/2-13 x 1-3/4
3	817490508	Screw, Hex Thrdrol 5/16-18 x 1/2
4	532121925	Plate, Steering Support
5	532121926	Gear, Sector
6	532121927	Bushing
7	873030800	Nut, Heavy Hex Top Lock 1/2-13 UNC
8	532126472	Clip, Insulated
9	873680800	Nut, Crownlock 3/8-16
10	876020412	Pin, Cotter 1/8 x 3/4

KEY NO.	PART NO.	DESCRIPTION
11	819131316	Washer, 13/32 x 13/16 x 16 Ga.
12	532126847	Bushing
13	874760516	Bolt, Hex Hd. 5/16-18 UNC x 1
14	819111416	Wahser 11/32 x 7/8 x 16 Ga.
15	872110606	Bolt, Carriage 3/8-16 UNC x 3/4
16	872140622	Bolt, Carriage
17	532121912	Support, Front Axle
18	873220600	Nut, Fin Hex 3/8-16 UNC
19	873930600	Nut, Centerlock 3/8-16 UNC
20	873680600	Nut, Crownlock 3/8-16 UNC
21	873680500	Nut, Crownlock 5/16-18

HARDWARE SHOWN LARGER FOR EASIER IDENTIFICATION

ILLUSTRATED PARTS BREAKDOWN

FRONT AXLE

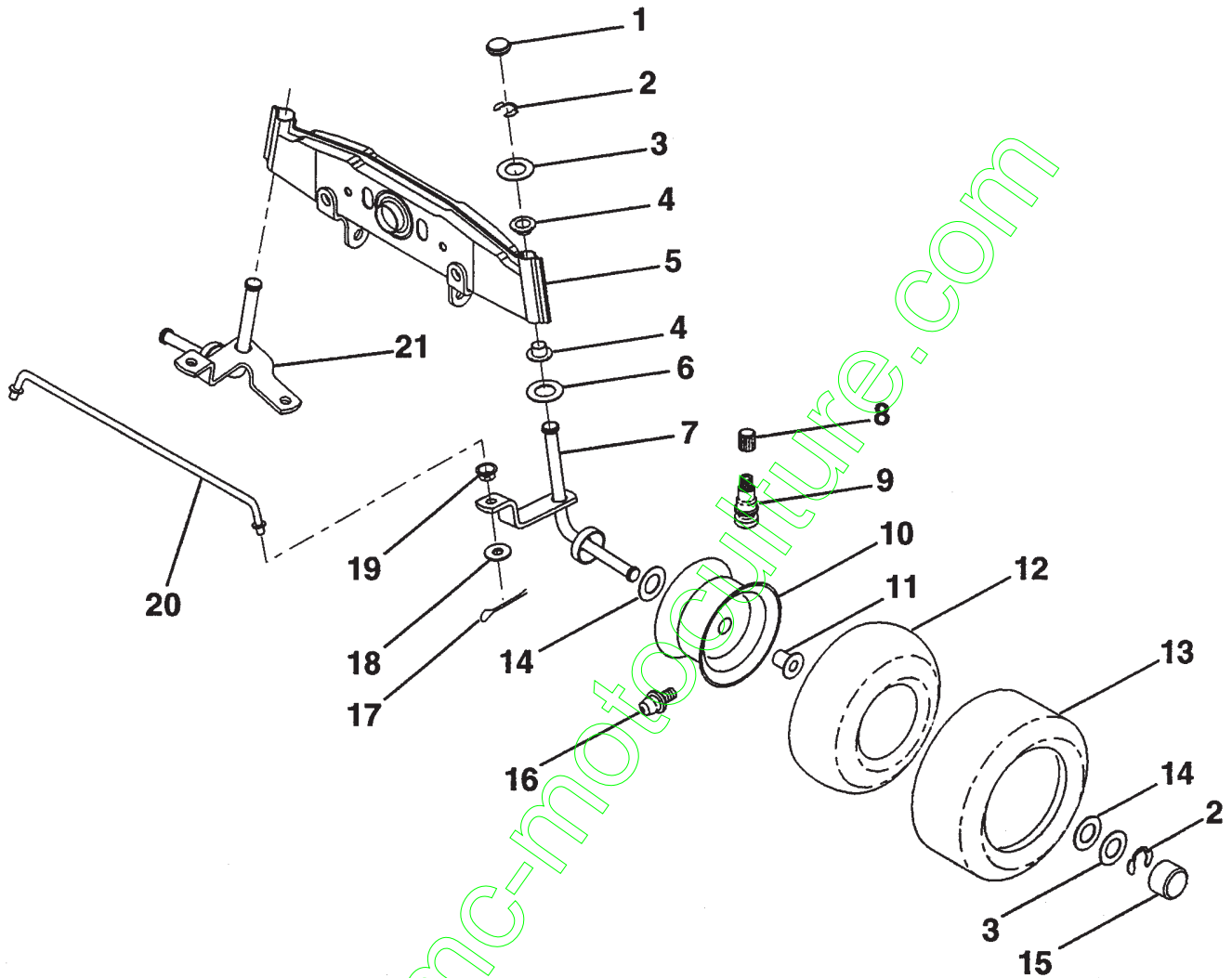

KEY NO.	PART NO.	DESCRIPTION
1	532121232	Cap, Spindle
2	812000029	Ring, Clip
3	532121748	Washer 25/32 x 1-5/8 x 16 Ga.
4	532121922	Nyloner
5	532128543	Axle, Front
6	532124931	Bearing, Thrust
7	532121919	Spindle, R.H. Asm.
8	532059192	Cap, Valve
9	532065139	Stem, Valve
10	532124972	Rim
11	532124959	Bearing, Flange

KEY NO.	PART NO.	DESCRIPTION
12	532059904	Tube
13	532124142	Tire, Front
14	532121749	Washer 25/32 x 1-1/4 x 16 Ga.
15	532104757	Cap, Axle
16	532124957	Fitting, Grease
17	876020412	Pin, Cotter 1/8 x 3/4
18	819131316	Washer 13/32 x 13/16 x 16 Ga.
19	532126847	Bushing
20	532121924	Rod, Tie
21	532121916	Spindle, L.H. Asm.

HARDWARE SHOWN LARGER FOR EASIER IDENTIFICATION

ILLUSTRATED PARTS BREAKDOWN

BRAKE / REAR MOWER LIFT ASSEMBLY

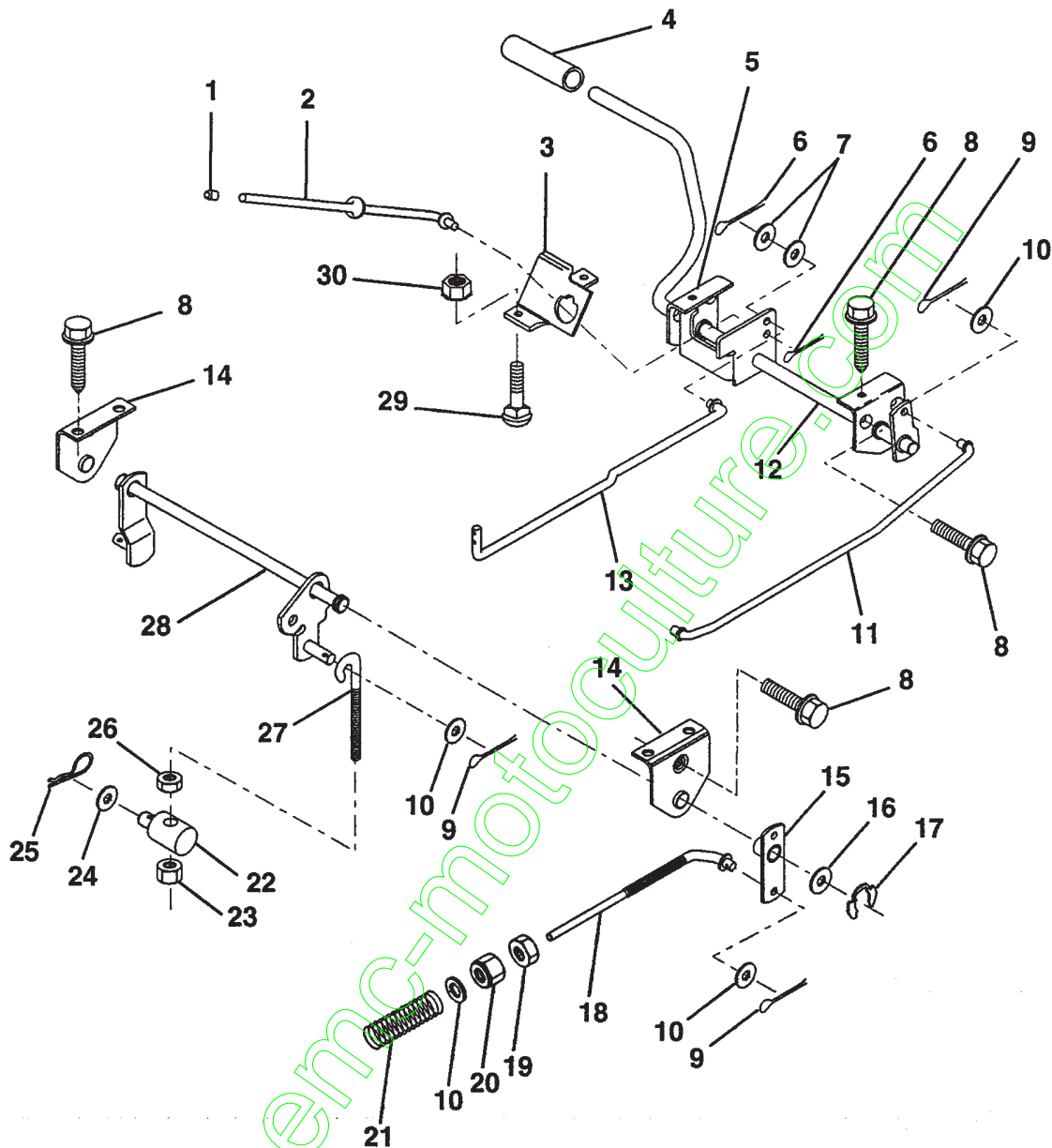

KEY NO.	PART NO.	DESCRIPTION	KEY NO.	PART NO.	DESCRIPTION
1	532071673	Cap, Plunger	16	819251816	Washer 25/32 x 1-1/8 x 16 Ga.
2	532123436	Rod, Parking Brake	17	812000034	Ring, Klip
3	532123437	Bracket, Parking Brake	18	532131460	Rod, Rear Brake
4	532008156	Cover, Pedal	19	873350600	Nut, Hex, Jam 3/8-16 UNC
5	532122504	Bracket, Clutch/Brake Pedal, L.H.	20	873800600	Locknut, Hex w/Washer Insert 3/8-16 UNC
6	876020312	Pin, Cotter 3/32 x 3/4	21	532106888	Spring, Brake Rod
7	819131016	Washer 13/32 x 5/8 x 16 Ga.	22	532127378	Trunnion, Lift
8	817490508	Screw, Hex, Thd. Roll. 5/16-18 x 1/2	23	873680600	Nut, Crownlock 3/8-16 UNC
9	876020412	Pin, Cotter 1/8 x 3/4	24	819132012	Washer 13/32 x 1-1/4 x 12 Ga.
10	819131316	Washer 13/32 x 13/16 x 16 Ga.	25	532124961	Spring, Retainer
11	532123543	Rod, Brake Front	26	873930600	Nut, Centerlock 3/8-16 UNC
12	532129567	Assembly, Clutch/Brake Pedal	27	532127369	Link, Threaded
13	532123394	Rod, Clutch	28	532127358	Assembly, Rear Mower Lift
14	532121978	Bracket, Lift, Shaft	29	872110506	Bolt, Carriage 5/16-18 UNC x 3/4
15	532123641	Assembly, Brake, Pivot, Arm	30	873510500	Nut, Keps 5/16-16 UNC

HARDWARE SHOWN LARGER FOR EASIER IDENTIFICATION

ILLUSTRATED PARTS BREAKDOWN

ENGINE / THROTTLE

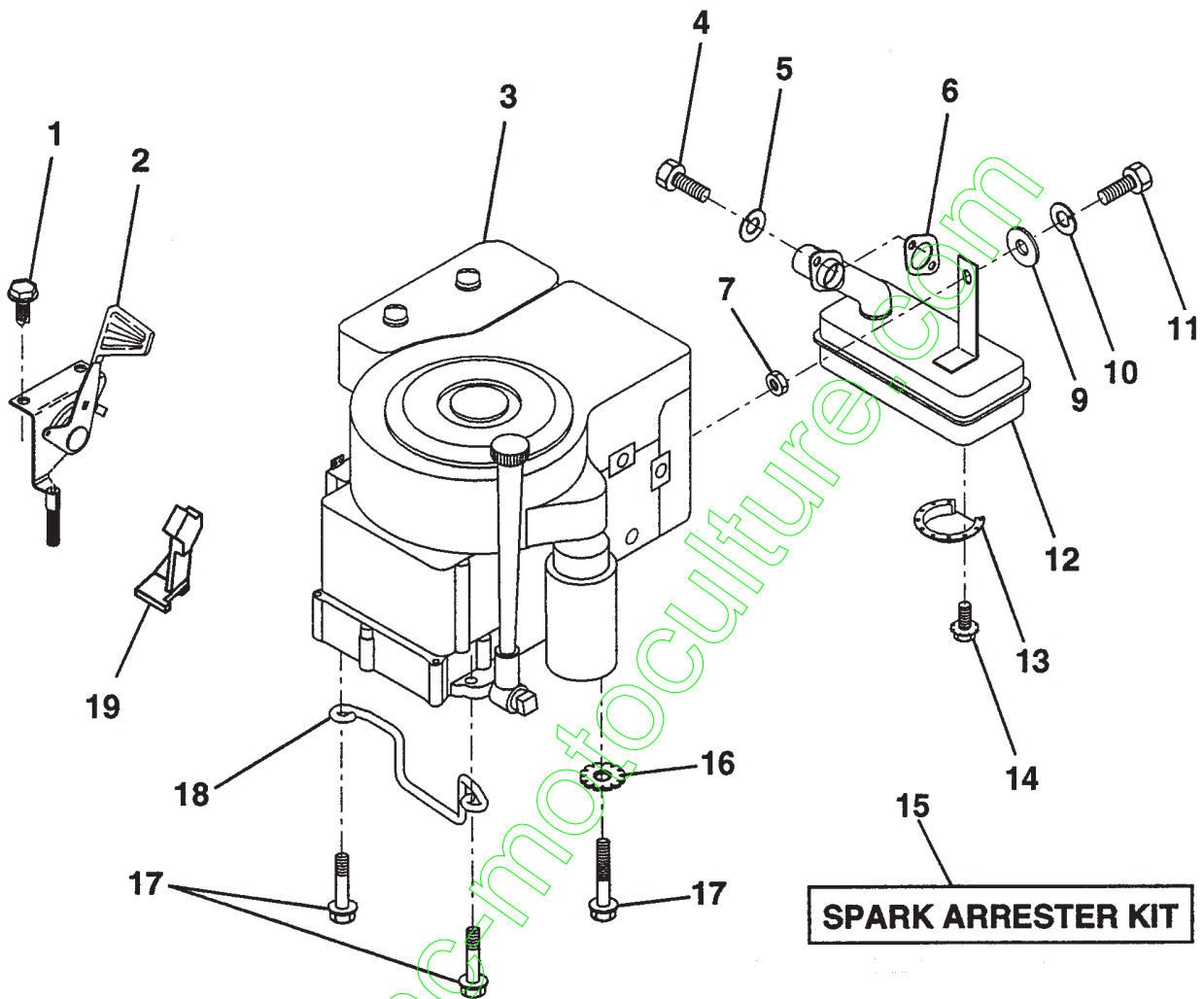

KEY NO.	PART NO.	DESCRIPTION
1	817720408	Screw, Hex Thd. Cut 1/4-20 x 1/2
2	532133025	Control, Throttle
3	532121797	Engine, Briggs and Stratton Model No. 255707
4	871070512	Screw, Hex, Cap 5/16-18 x 3/4
5	810040500	Washer, Lock Heavy Helical Spring 5/16
6	532125593	Gasket, Exhaust
7	873220500	Nut, Hex 5/16-18
9	819101216	Washer 5/16 x 3/4 x 16
10	810040400	Washer, Lock Heavy Helical Spring 1/4

KEY NO.	PART NO.	DESCRIPTION
11	874780420	Bolt, Hex Fin. 1/4-20 UNC x 1-1/2
12	532123676	Muffler
13	532101326	Deflector, Muffler
14	817030808	Screw, Spiderlock Hex Hd. 8 x 1/2 ABTPS
15	532121851	Arrester, Spark (Optional equipment)
16	811050600	Lock, Washer Ext. Tooth 3/8
17	817490624	Screw, Hex Wsh Hd Thdrol 3/8-16 x 1-1/2
18	532126636	Keeper, Ground Drive Belt Stop, Throttle
19	532133097	

HARDWARE SHOWN LARGER FOR EASIER IDENTIFICATION

ILLUSTRATED PARTS BREAKDOWN

GROUND DRIVE

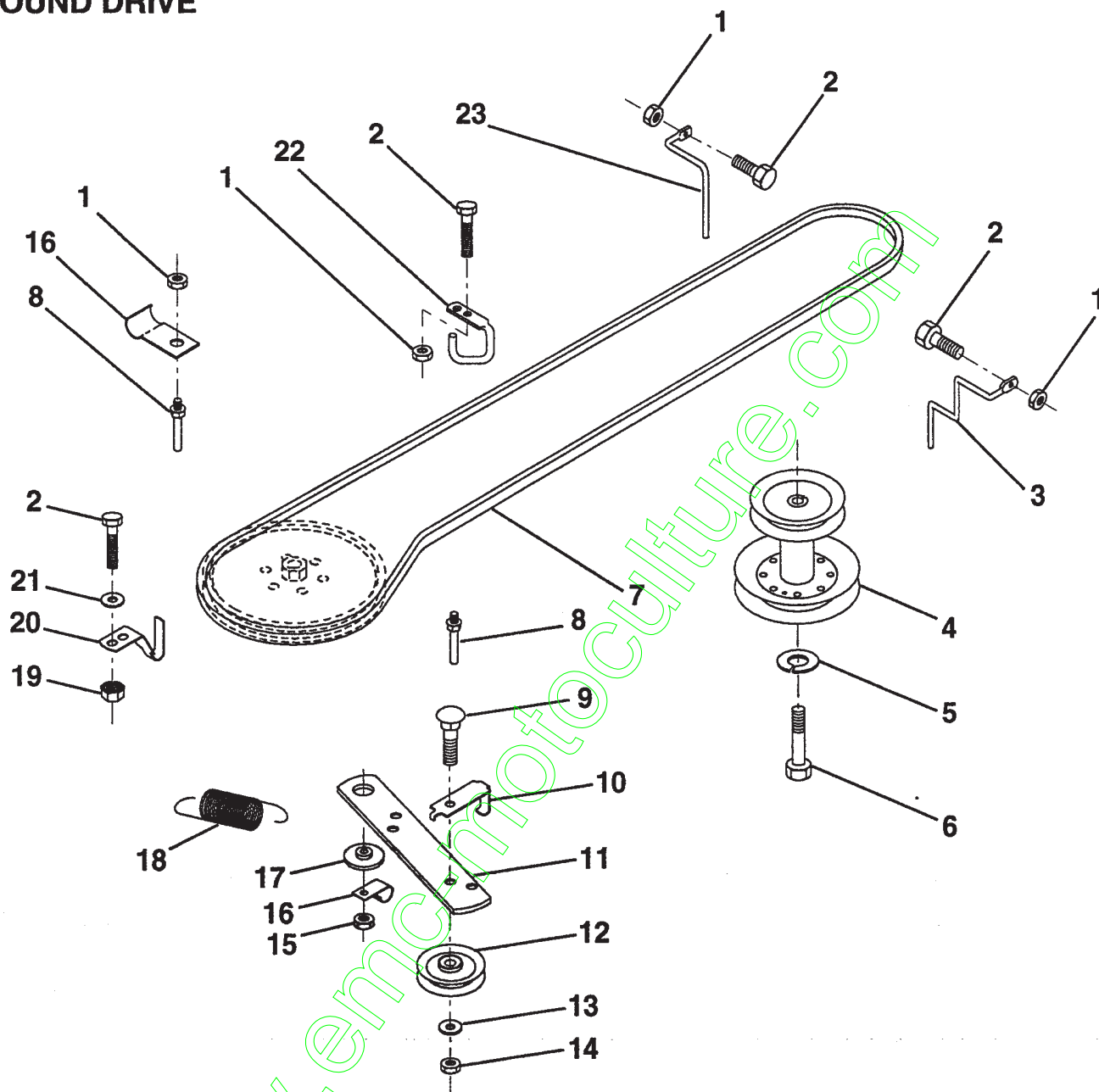

KEY NO.	PART NO.	DESCRIPTION	KEY NO.	PART NO.	DESCRIPTION
1	873680500	Nut, Crownlock 5/16-18	13	819131316	Washer 13/32 x 13/16 x 16 Ga.
2	874760512	Bolt, Hex Hd 5/16-18 UNC x 3/4	14	873930600	Nut, Centerlock 3/8-16 UNC
3	532131205	Keeper, Mower Drive, R. H.	15	873680600	Nut, Crownlock 3/8-16 UNC
4	532123400	Pulley, Engine	16	532126471	Clip, Insulated
5	810040700	Washer, Lock 7/16	17	532122052	Spacer, Retainer
6	871130720	Bolt, Fin Hex 7/16-20	18	532131459	Spring Extension
7	532126520	Traction, V-Belt Drive	19	873510500	Nut, Keps 5/16-18 UNC
8	532123405	Keeper, T/A Ground Drive Belt	20	532123891	Keeper, T/A Ground Drive Belt
9	872140612	Bolt, Carr. 3/8-16 UNC x 1-1/2	21	819111016	Washer 11/32 x 5/8 x 16 Ga.
10	532123396	Keeper, Belt Ground Drive Idler	22	532123404	Keeper, Frame Ground Drive Belt
11	532123395	Arm, Ground Drive Clutch	23	532131204	Keeper, Mower Drive, L. H.
12	532004859	Idler, Flat			

HARDWARE SHOWN LARGER FOR EASIER IDENTIFICATION

ILLUSTRATED PARTS BREAKDOWN

TRANSAXLE

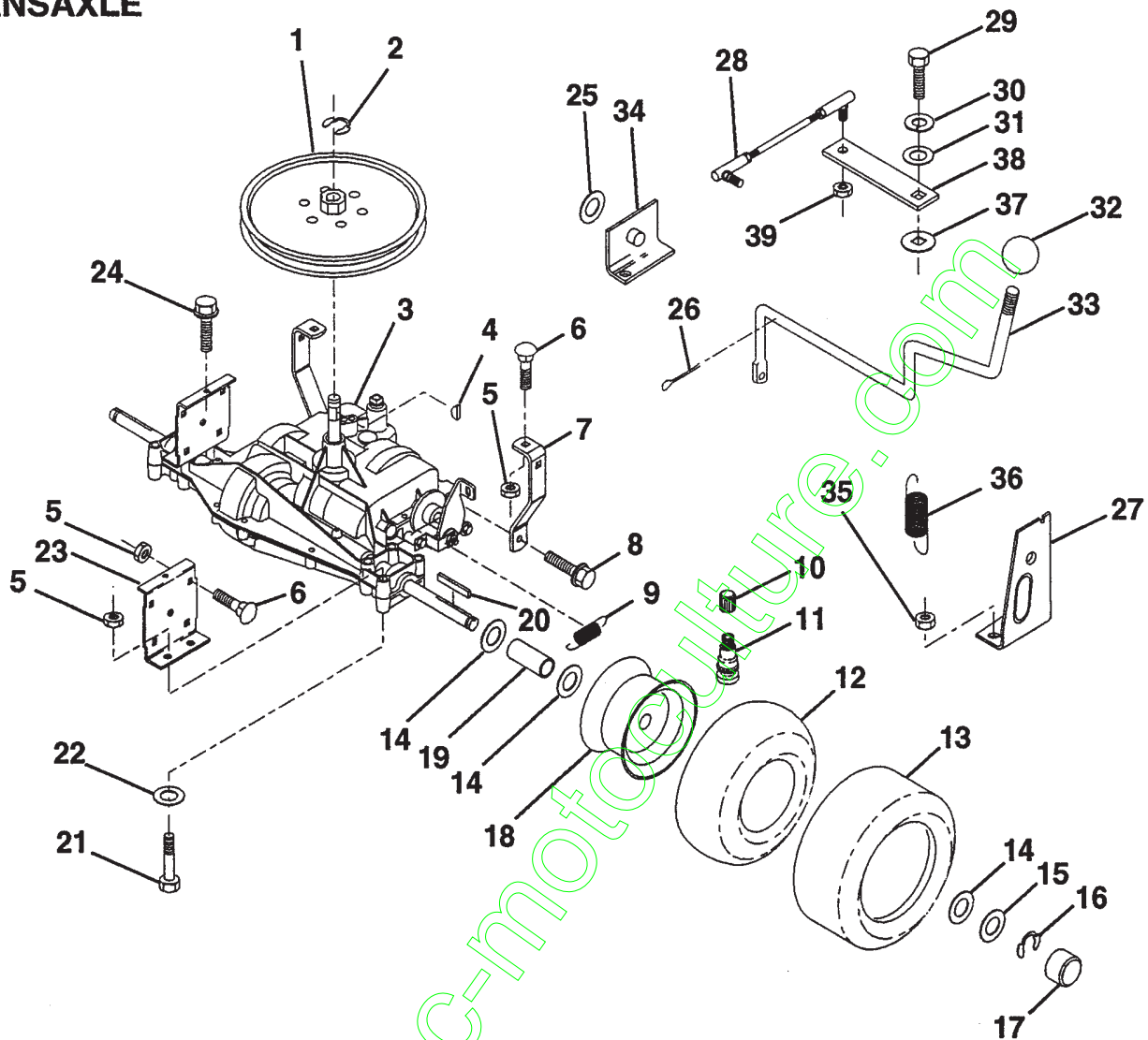

KEY NO.	PART NO.	DESCRIPTION	KEY NO.	PART NO.	DESCRIPTION
1	532123385	Pulley	20	532123583	Key, Square
2	812000028	Ring, Retainer	21	874760540	Bolt, Fin Hex 5/16-18 x 2-1/2
3	532127052	Transaxle, Peerless 4 speed Model No. 930-026	22	819111116	Washer 11/32 x 11/16 x 16 Ga.
4	532125096	Key, Woodruff #9	23	532123377	Bracket, Transaxle
5	873680500	Nut, Crownlock 5/16-18	24	817490512	Screw 5/16-18 x 3/4
6	872140506	Bolt, Carriage 5/16-18 UNC x 3/4	25	819171616	Washer 17/32 x 1 x 16 Ga.
7	532123378	Strap, Torque	26	876020416	Pin, Cotter 1/8 x 1
8	817490508	Screw, Hex Thdrol 5/16-18 x 1/2	27	532128084	Support, Handle Shift R. H.
9	532110422	Spring, Brake	28	532126293	Link, Shift
10	532059192	Cap, Valve	29	871040412	Bolt, Fin Hex 1/4-28 UNF x 3/4 Gr. 8
11	532065139	Stem, Valve	30	810040400	Washer, Lock 1/4
12	532008134	Tube	31	819091210	Washer 9/32 x 3/4 x 10 Ga.
13	532124143	Tire, Rear	32	532106933	Knob, Shift Control
14	532121749	Washer 25/32 x 1-1/4 x 16 Ga.	33	532128215	Shift Rod
15	532121748	Washer 35/32 x 1-5/8	34	532124600	Support, Handle Shift L. H.
16	812000001	E-Ring	35	873510500	Nut, Keps 5/16-18
17	532104757	Hub, Cap	36	532128085	Extension, Spring
18	532124973	Rim	37	532105701	Washer, Shift Plate
19	532123409	Spacer	38	532126292	Arm, Shift
			39	873810500	Nut, Hex Nylon

HARDWARE SHOWN LARGER FOR EASIER IDENTIFICATION

ILLUSTRATED PARTS BREAKDOWN

MOWER LIFT LEVER

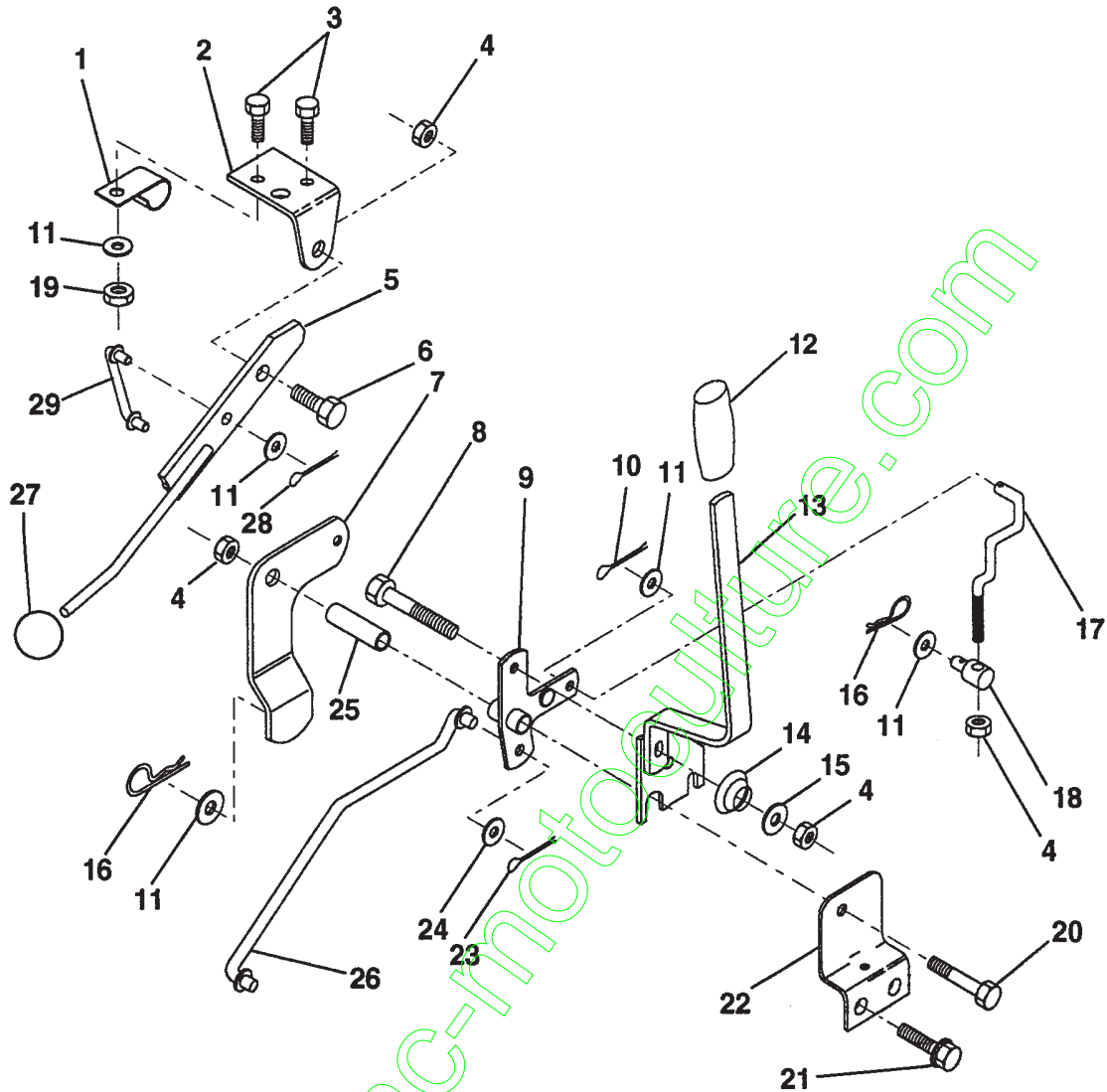

KEY NO.	PART NO.	DESCRIPTION	KEY NO.	PART NO.	DESCRIPTION
1	532126470	Clip, Insulated	16	532124961	Retainer, Spring
2	532122018	Bracket, Mower Clutch	17	532127359	Link, Front Lift
3	874780408	Bolt, Fin Hex 1/4-20 UNC x 1/2 Gr. 5	18	532133205	Trunnion, Threaded 3/8-16
4	873680600	Nut, Crownlock 3/8-16 UNC	19	873680400	Nut, Crownlock 1/4-20
5	532123417	Assembly, Clutch Lever	20	874760644	Bolt, Fin Hex 3/8-16 UNC x 2-3/4
6	532106451	Bolt, Shoulder	21	817490508	Screw, Hex Thdrol. 5/16-18 x 1/2
7	532123491	Assembly, Mower Clutch Arm	22	532121929	Bracket, Mower Height
8	874760636	Bolt, Hex 3/8-16 UNC x 2-1/4	23	876020416	Pin, Cotter 1/8 x 1
9	532121930	Assembly, Bracket Lift	24	819171616	Washer 17/32 x 1 x 16 Ga.
10	876020412	Pin, Cotter 1/8 x 3/4	25	532121933	Tube, Spacer
11	819131316	Washer 13/32 x 13/16 x 16 Ga.	26	532121934	Rod, Mower Lift
12	532131861	Grip, Handle	27	532106932	Knob
13	532127028	Assembly, Lift Handle	28	876020312	Pin, Cotter 3/32 x 3/4
14	532123496	Spring, Compression	29	532123671	Link, Mower Clutch
15	819131212	Washer 13/32 x 3/4 x 12 Ga.			

HARDWARE SHOWN LARGER FOR EASIER IDENTIFICATION

ILLUSTRATED PARTS BREAKDOWN

MOWER DECK

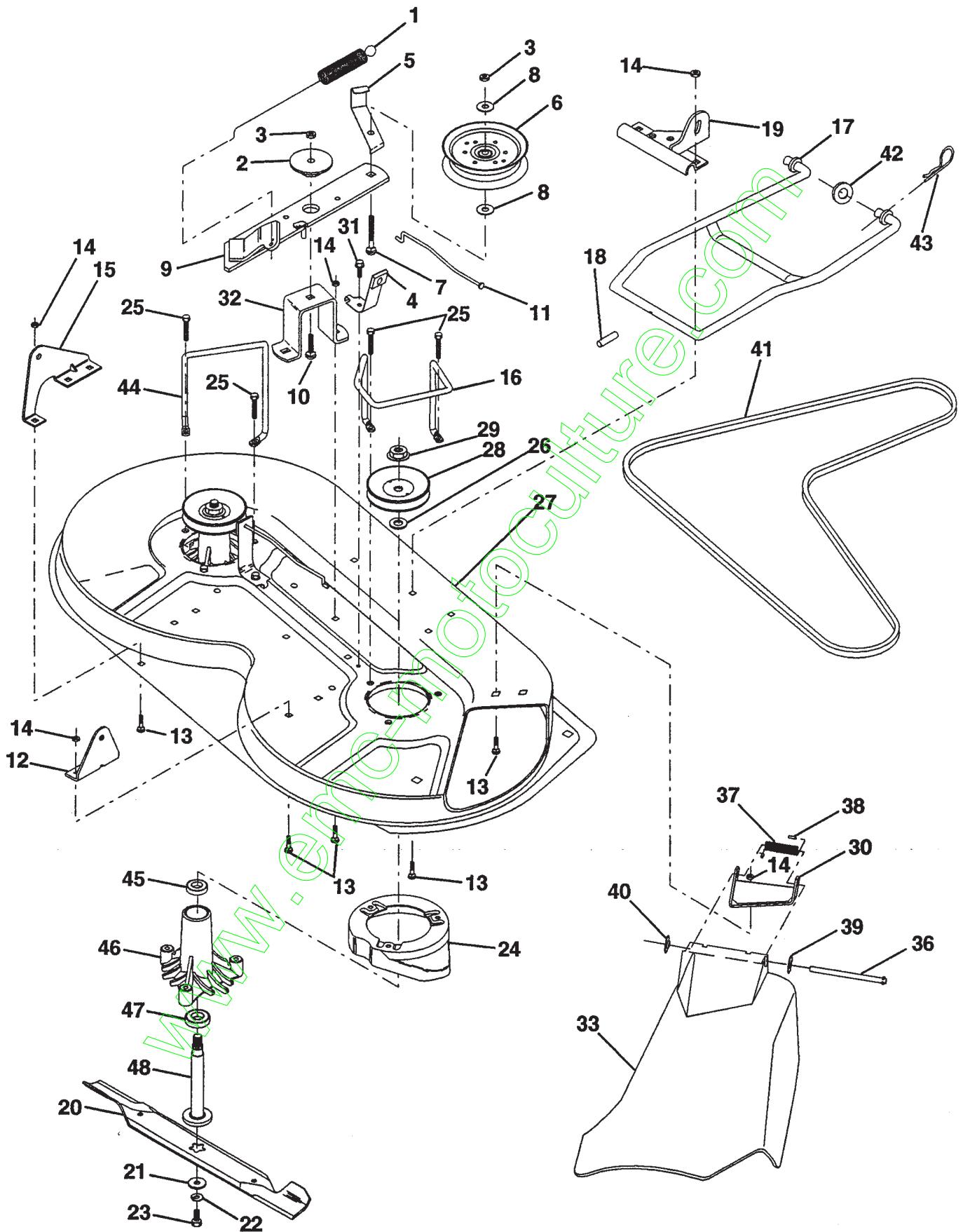

ILLUSTRATED PARTS BREAKDOWN

MOWER DECK

KEY NO.	PART NO.	DESCRIPTION	KEY NO.	PART NO.	DESCRIPTION
1	532127743	Spring, Mower Clutch	25	532078158	Bolt 5/16-18 x 1-1/4
2	532122052	Spacer, Retainer	26	532129963	Washer .150 Thk.
3	873680600	Nut, Crownlock	27	532129983	Deck Assembly
4	532130840	Brake Asm.	28	532129207	Pulley, Mandrel
5	532131251	Guide, Belt Idler	29	873040900	Nut, Flangelock 9/16
6	532121316	Pulley, Flat Idler	30	532126361	Bracket, Asm. Deflector
7	872110616	Bolt, Carr. 3/8-16 x 2 Gr. 5	31	817490508	Screw, Hex Wsh. Thdrol. 5/16-18 x 1/2
8	819131410	Washer 13/21 x 7/8 x 10 Ga.	32	532122051	Arm, Support Idler Mower
9	532127744	Arm Asm., Idler Mower	33	532131560	Deflector
10	872110608	Bolt, Carriage 3/8-16 x 1	36	532121980	Rod, Hinge
11	532130841	Rod, Brake	37	532123713	Spring, Torsion Deflector
12	532127356	Bracket, Lift R. H. Rear	38	532105304	Cap, Sleeve
13	872140505	Bolt, Carriage 5/16-18 x 5/8	39	819111016	Washer 11/32 x 5/8 x 16 Ga.
14	873680500	Nut, Crownlock 5/16-18	40	532110452	Push Nut
15	532127357	Bracket, Lift L. H. Rear	41	532131264	V-Belt
16	532130837	Keeper, R. H.	42	819171616	Washer 11/32 x 5/8 16 Ga.
17	532128508	Link, Asm. Mower Stabilizer	43	532124660	Retainer, Spring
18	532128511	Pin, Drive	44	532130836	Keeper, L. H.
19	532127380	Bracket, Asm. Front	45	532110485	Bearing
20	532127841	Blade	46	532130794	Mandrel Asm. (Includes Key No.'s 22, 23, 26, 29 and 45-48)
21	532129962	Washer, Hard	47	532129895	Bearing
22	810030600	Washer, Lock 3/8	48	532128285	Shaft, Mandrel
23	532850857	Bolt 3/8-24 x 1-1/4 Gr. 8			
24	532128961	Stripper			

HARDWARE SHOWN LARGER FOR EASIER IDENTIFICATION

www.emc-motocult.com

ILLUSTRATED PARTS BREAKDOWN

DECALS

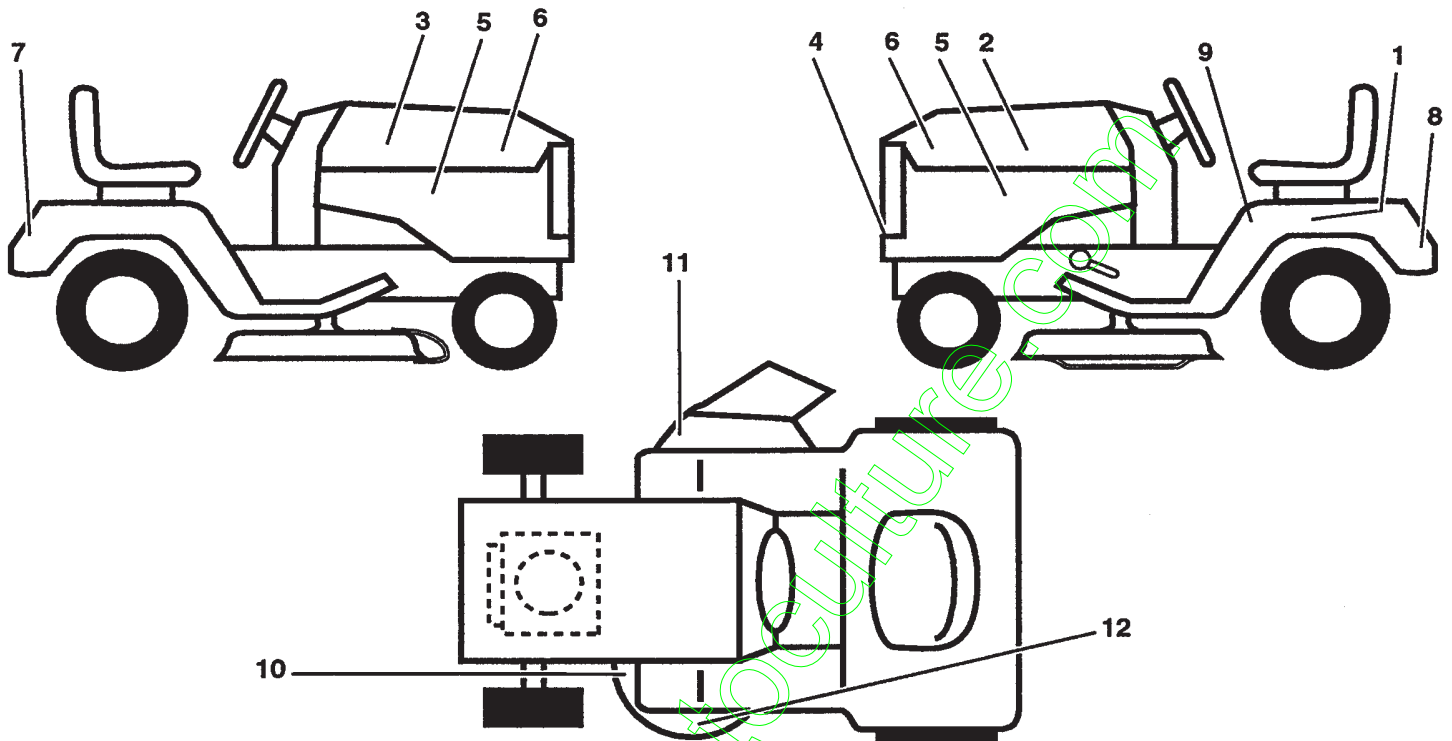

KEY PART NO.	PART NO.	DESCRIPTION	KEY PART NO.	PART NO.	DESCRIPTION
1	532121549	Decal, Caution, Battery			
2	532131579	Decal, Stripe, R.H. Hood			
3	532131580	Decal, Stripe, L.H. Hood			
4	532125989	Decal, Grill			
5	532131581	Decal, Side Panel			
6	532131660	Decal, Hood			
7	532131582	Decal, Logo, Fender			
8	532126187	Decal, Certification			
--	532125690	Decal, 100 DBA			
9	532126155	Decal, Instruction, Warning, (Swedish/Danish/Finnish/Norwegian)			
--	532126156	Decal, Instruction, Warning, (French/German/English/Dutch)			
--	532126348	Decal, Instruction, Warning, (Spanish/Italian)			
10	532126193	Decal, Caution, Deflector, (Swedish/Danish/Finnish/Norwegian)			
--	532126194	Decal, Caution, Deflector, (French/German/English/Dutch)			
--	532126347	Decal, Caution, Deflector, (Spanish/Italian)			
11	532126191	Decal, Warning, Cut Finger, (Swedish/Danish/Finnish/Norwegian)			
--	532126192	Decal, Warning, Cut Finger, (English/French/German/Dutch)			
--	532126345	Decal, Warning, Cut Finger, (Spanish/Italian)			
12	532126195	Decal, Rotating Blades, (Swedish/Danish/Finnish/Norwegian)			
--	532126196	Decal, Rotating Blades, (English/French/German/Dutch)			
--	532126346	Decal, Rotating Blades, (Spanish/Italian)			
--	532101539	Sheet, Instruction, Tractor, 15 Degree Slope, (English)			
--	532101572	Sheet, Instruction, Tractor, 15 Degree Slope, (French)			
--	532131074	Manual, Operator's (Swedish/Danish/Finnish/Norwegian)			
--	532131075	Manual, Operator's (French/German/English/Dutch/Spanish/Italian)			