

LT 130



1.1997

Spare parts

Ersatzteile

Pièces détachées

Reserve onderdelen

Repuestos

Reservdelar

Replaces

Ersetzt

Remplace

Vervangt

Reemplaza

Ersätter

REPAIR PARTS

A TRACTOR - MODEL NO. LT130 (HE1336D), PRODUCT NO. 954 82 00-81 HOOD

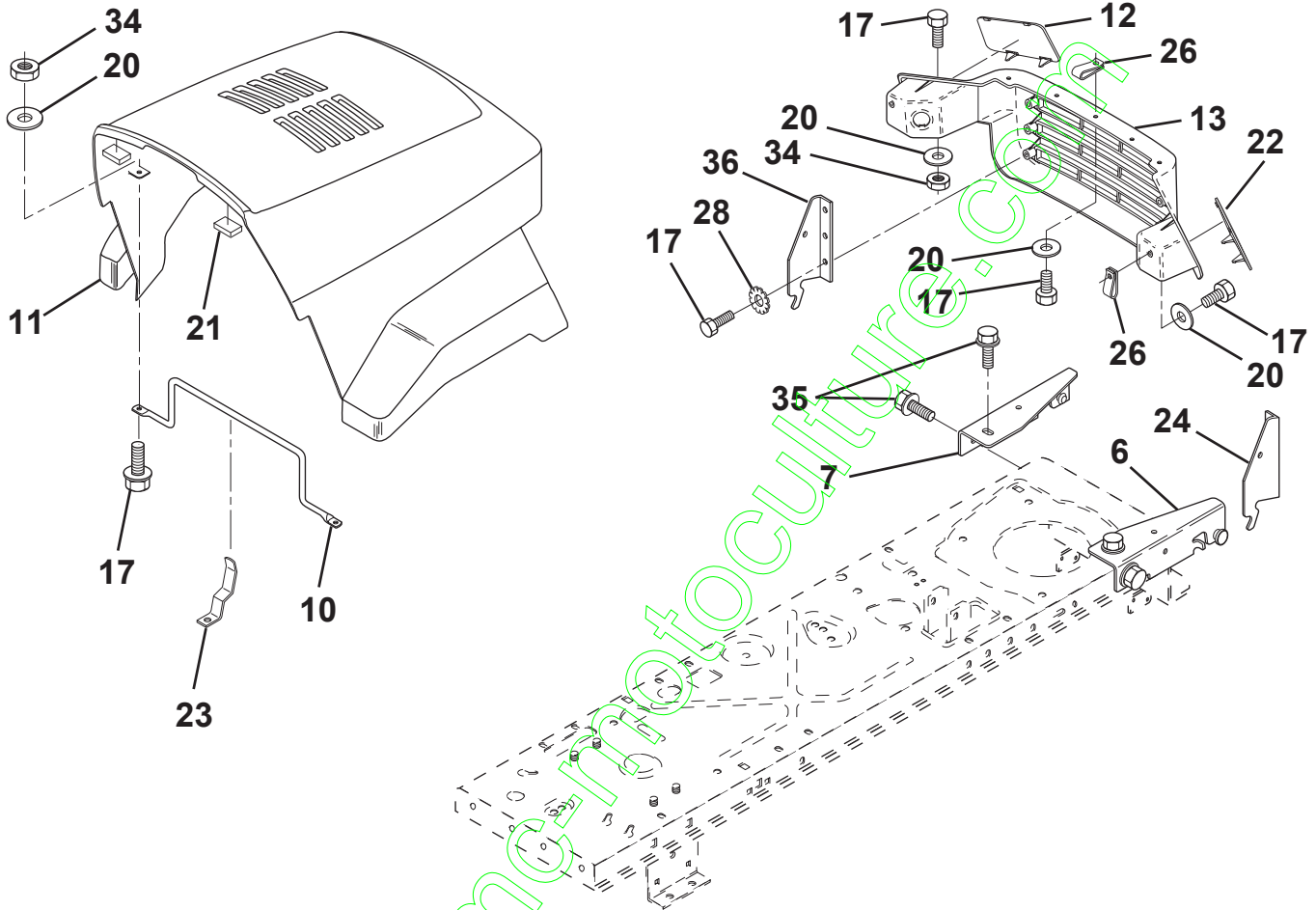

KEY NO.	PART NO.	DESCRIPTION
6	532140051	Bracket, Asm. Pivot Frame RH
7	532140050	Bracket, Asm. Pivot Frame LH
10	532130850	Brace, Hood
11	532140142	Hood
12	532130986	Lens, LH
13	532130984	Grille
17	874780410	Bolt, Fin Hex 1/4-20 x 5/8
20	819091016	Washer, Flat 1/4
21	532126938	Bumper, Hood
22	532130985	Lens RH

KEY NO.	PART NO.	DESCRIPTION
23	532139969	Latch, Hood
24	532142873	Bracket, Pivot Hood RH
26	532052921	Clip, Tinnerman
28	811050400	Washer, Lock Ext. Tooth 1/4
34	873680400	Nut, Fin Hex 1/4-20
35	817490512	Screw, Thdrol 5/16-18 x 3/4
36	532128445	Bracket, Pivot Hood LH

NOTE: All component dimensions given in U.S. inches
1 inch = 25.4 mm

HARDWARE SHOWN LARGER FOR EASIER IDENTIFICATION

B

FENDER/CHASSIS

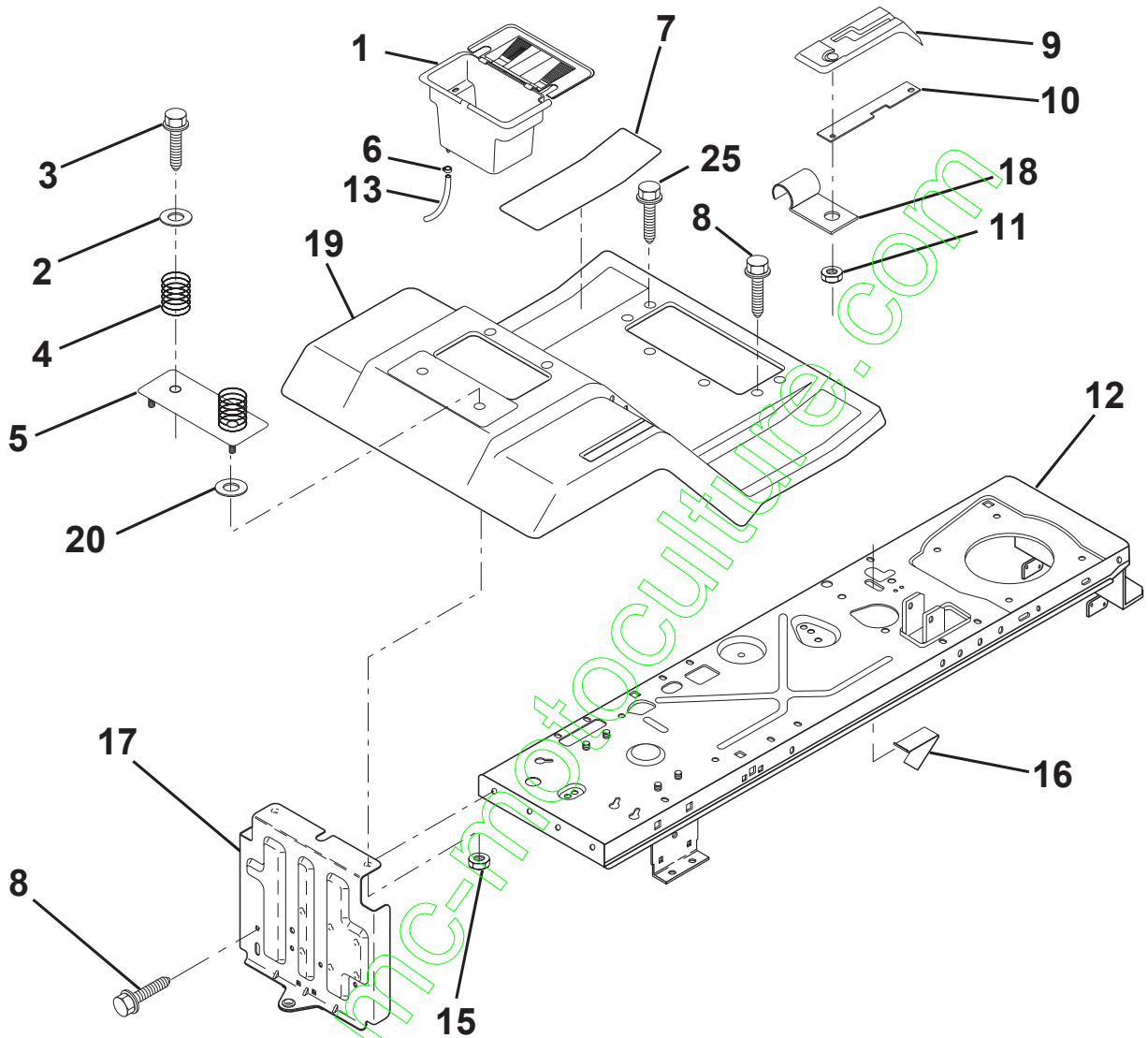

KEY NO.	PART NO.	DESCRIPTION
1	532144940	Case, Battery
2	819132012	Washer 13/32 x 1-1/4 x 12 Ga.
3	817490612	Screw, Hex Wsh. Thrdrol. 3/8-16 x 3/4
4	532124181	Spring, Compression, Seat
5	532125142	Plate, Asm. Battery
6	532109596	Clamp, Hose
7	532126700	Pad, Footrest
8	817490512	Screw, Hex Wsh. Thrdrol. 5/16-18 x 3/4
9	532126995	Console, Shift Control
10	532139783	Plate, Shift Lock
11	532124346	Nut, Self-Threading, Wsh Hd 3/16

KEY NO.	PART NO.	DESCRIPTION
12	532145190	Assembly, Frame
13	532109238	Tube, Battery Drain
15	873640400	Nut, Keps 1/4-20 UNC
16	532141736	Switch Actuator
17	532140782	Drawbar
18	532126470	Clip, Insulated
19	532141393	Fender/Footrest
20	819091413	Washer 9/32 x 7/8 x 13 Ga.
25	817190516	Screw Hex 5/16-18 x 1

NOTE: All component dimensions given in U.S. inches
1 inch = 25.4 mm

HARDWARE SHOWN LARGER FOR EASIER IDENTIFICATION

C

SEAT

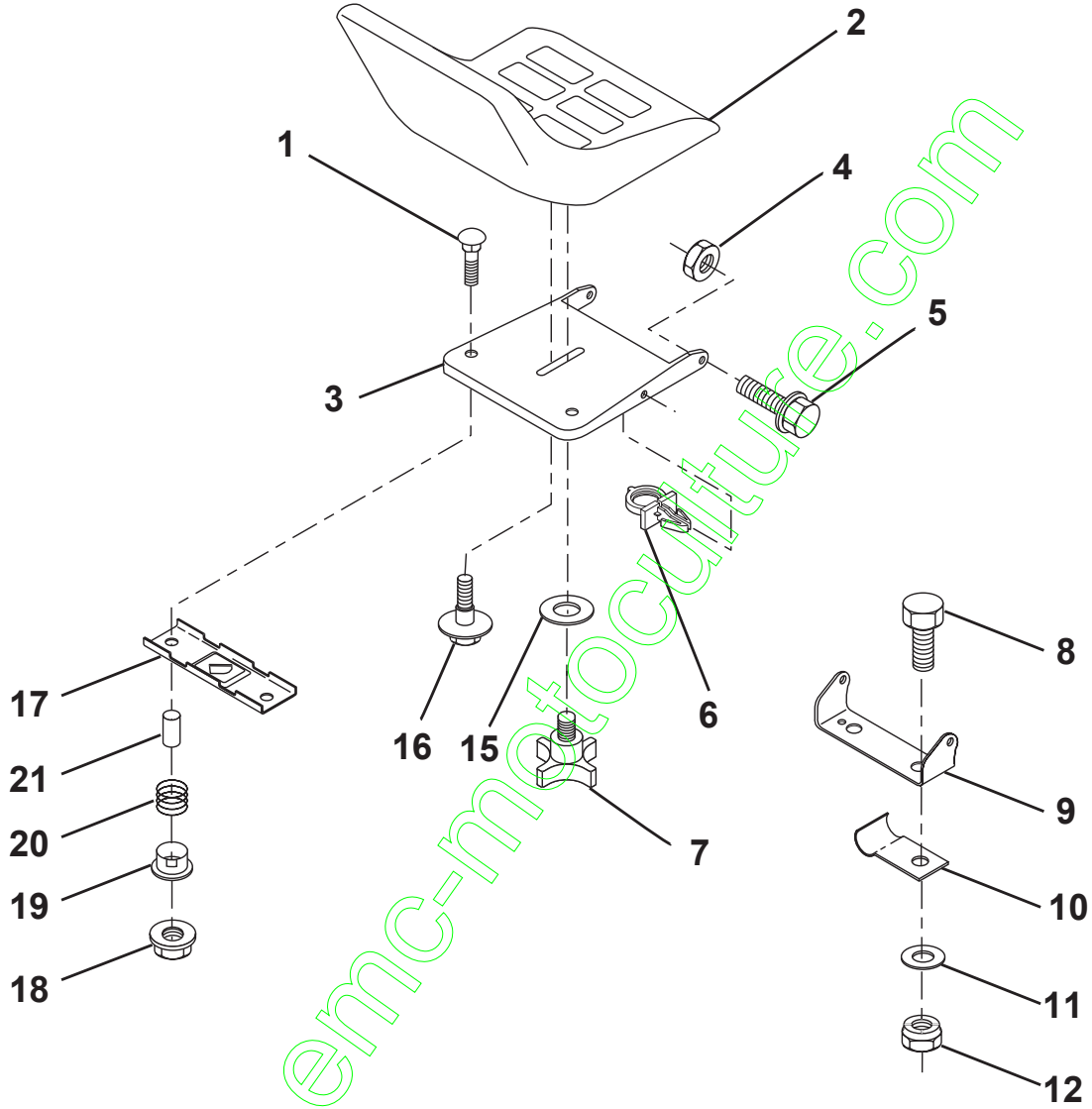

KEY NO.	PART NO.	DESCRIPTION
1	872050411	Bolt, Carriage 1/4-20 x 1-3/8
2	532140838	Seat
3	532155925	Pan, Seat
4	873800500	Nut, Lock Hex w/Ins. 5/16-18
5	532153236	Bolt, Shoulder 5/16-18
6	532145006	Clip, Push-In
7	532120068	Knob, Seat
8	874760616	Bolt, Fin Hex 3/8-16 UNC x 1
9	532140551	Bracket, Pivot Seat
10	532126471	Clip, Insulator
11	819133210	Washer 12/32 x 2 x 10 Ga.

KEY NO.	PART NO.	DESCRIPTION
12	873800600	Nut, Lock Hex w/Wsh 3/8-16
15	819171912	Washer, 17/32 x 1-3/16 x 12 Ga.
16	532127018	Bolt, Shoulder
17	532121246	Bracket, Switch, Mounting
18	532123976	Nut, Hex Large Flange Lock
19	532121248	Bushing, Snap
20	532121250	Spring, Compression
21	532134300	Spacer, Split 28 Id. x .96 Lg.

NOTE: All component dimensions given in U.S. inches
1 inch = 25.4 mm

HARDWARE SHOWN LARGER FOR EASIER IDENTIFICATION

D

DASH

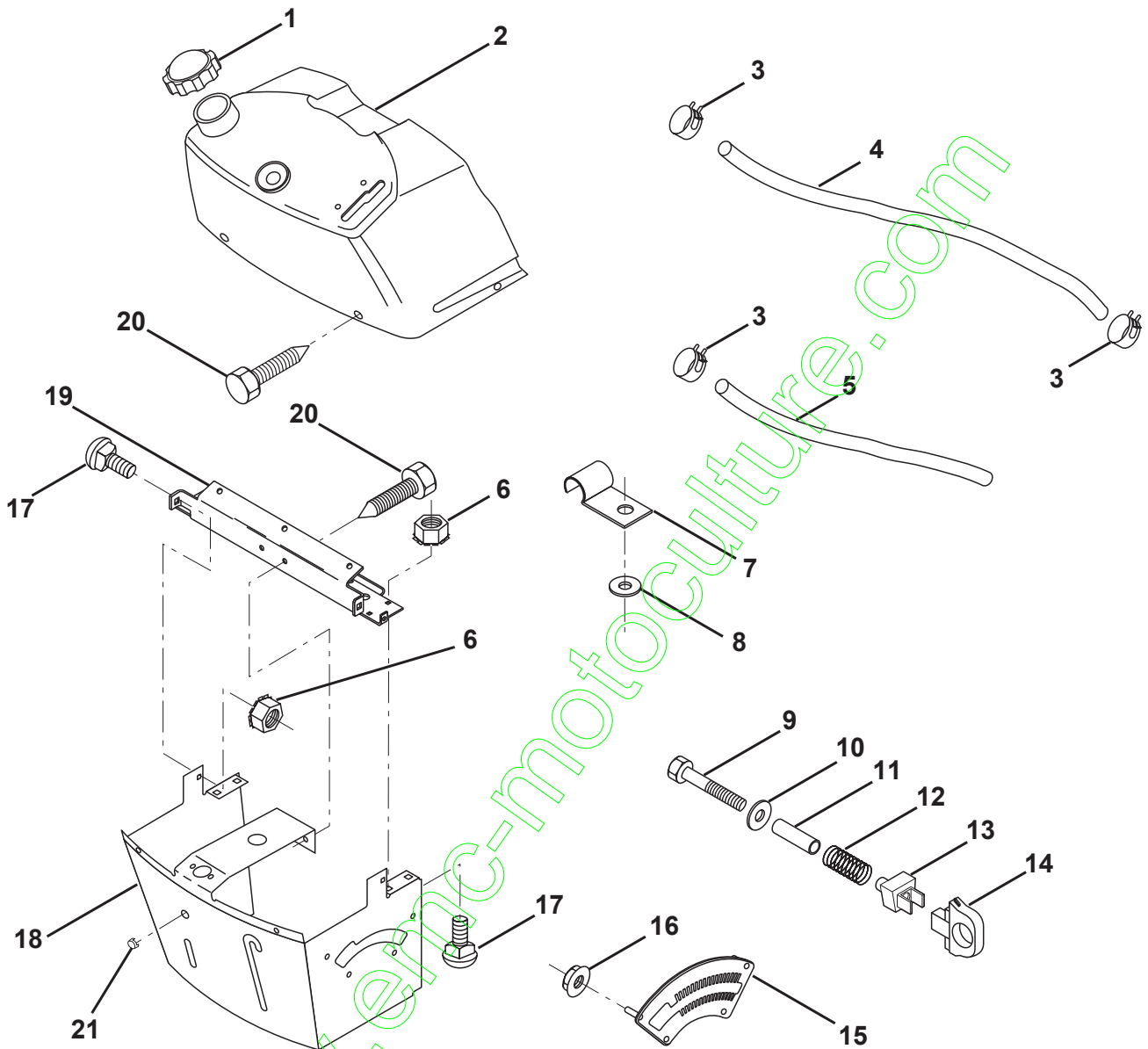

KEY NO.	PART NO.	DESCRIPTION
1	532142187	Cap, Fuel
2	532138395	Assembly, Dash & Fuel Tank
3	532123487	Clamp, Hose
4	532008544	Line, Fuel
5	532008548	Line, Fuel
6	873640400	Nut, Hex, Keps 1/4-20
7	532124996	Clip, Fuel Line
8	819091216	Washer 9/32 x 3/4 x 16 Ga.
9	874760428	Bolt, Hex, Fin 1/4-20 x 1-3/4
10	819091413	Washer 11/32 x 11/16 x 16 Ga.
11	532121249	Spacer, Split
12	532003720	Spring

KEY NO.	PART NO.	DESCRIPTION
13	532126450	Clip, Height Adjustment
14	532126115	Knob, Height Stop
15	532122023	Adjustment, Quadrant Height
16	532124346	Nut, Self-Threading 3/16-18
17	872110404	Bolt, Carriage 1/4-20 x 1/2 Gr. 5
18	532130745	Support Assembly, Dash
19	532134744	Brace, Cross
20	817060408	Screw, Self-Tapping 1/4-20 x 1/2
21	532134014	Plug Dome Black

NOTE: All component dimensions given in U.S. inches
1 inch = 25.4 mm

HARDWARE SHOWN LARGER FOR EASIER IDENTIFICATION

E

STEERING WHEEL

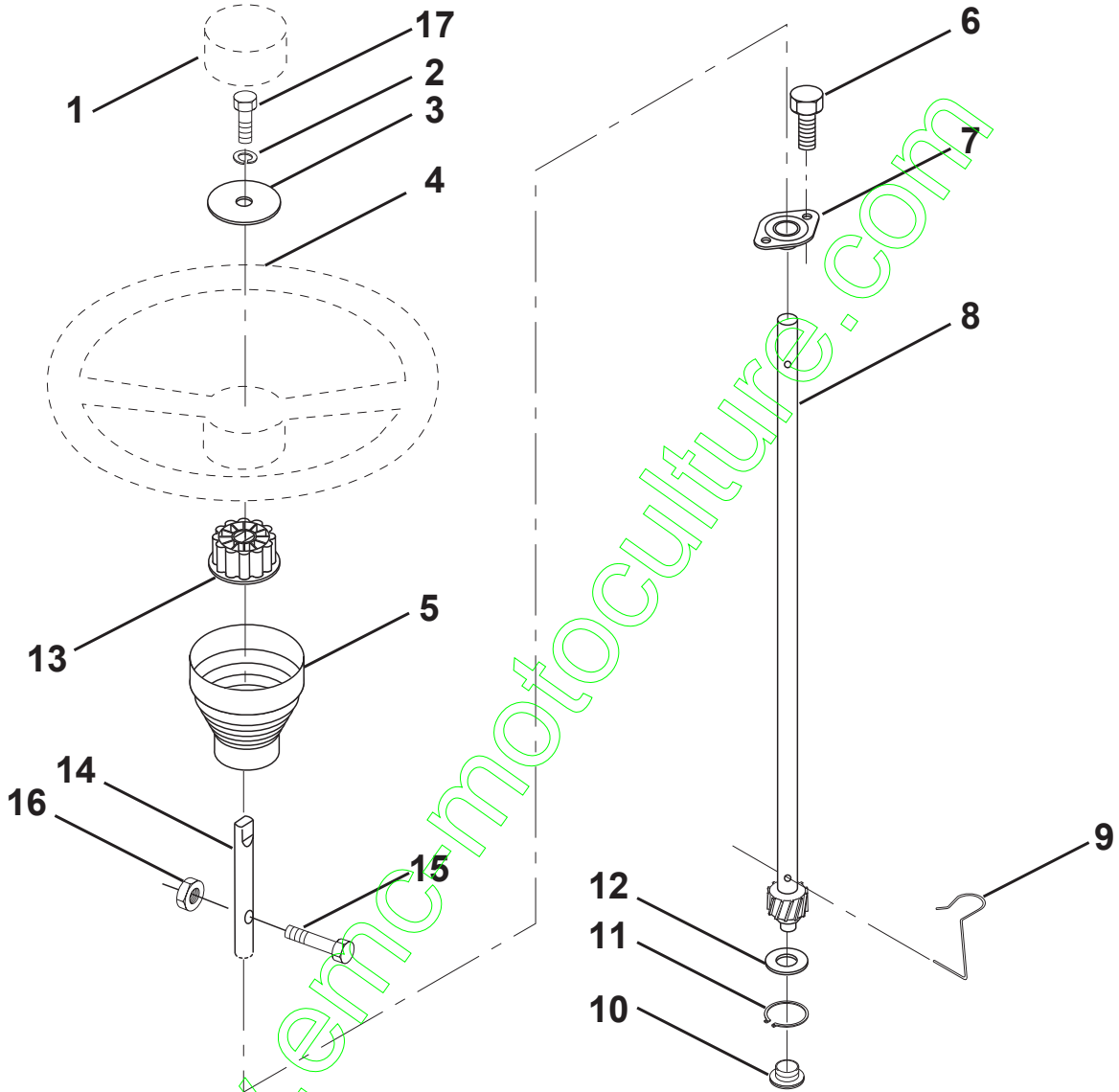

KEY NO.	PART NO.	DESCRIPTION
1	532124416	Insert, Wheel, Steering
2	810040600	Washer, Lock Hvy Hlcl
3	819133808	Washer 12/32 x 2-3/8 x 8 Ga.
4	532124415	Wheel, Steering
5	532127396	Sleeve, Steering
6	532152927	Screw TT #10-32 x 5 x 3/8 Flange
7	532155104	Bushing Steering
8	532147391	Shaft, Steering
9	532124210	Clip, Steering
10	532123438	Bushing, Lower, Steering

KEY NO.	PART NO.	DESCRIPTION
11	812000045	Ring, Retaining
12	819211616	Washer 21/32 x 1 x 16 Ga.
13	532100711	Adaptor, Wheel, Steering
14	532153720	Extension Shaft Steering
15	874780520	Bolt Fin Hex 5/16-18 Unc x 1-1/4
16	873800500	Nut, Lock Hex w/Ins. 5/16-18
17	874780616	Bolt Fin Hex 3/8-16 UNC x 1

NOTE: All component dimensions given in U.S. inches
1 inch = 25.4 mm

HARDWARE SHOWN LARGER FOR EASIER IDENTIFICATION

F

ENGINE

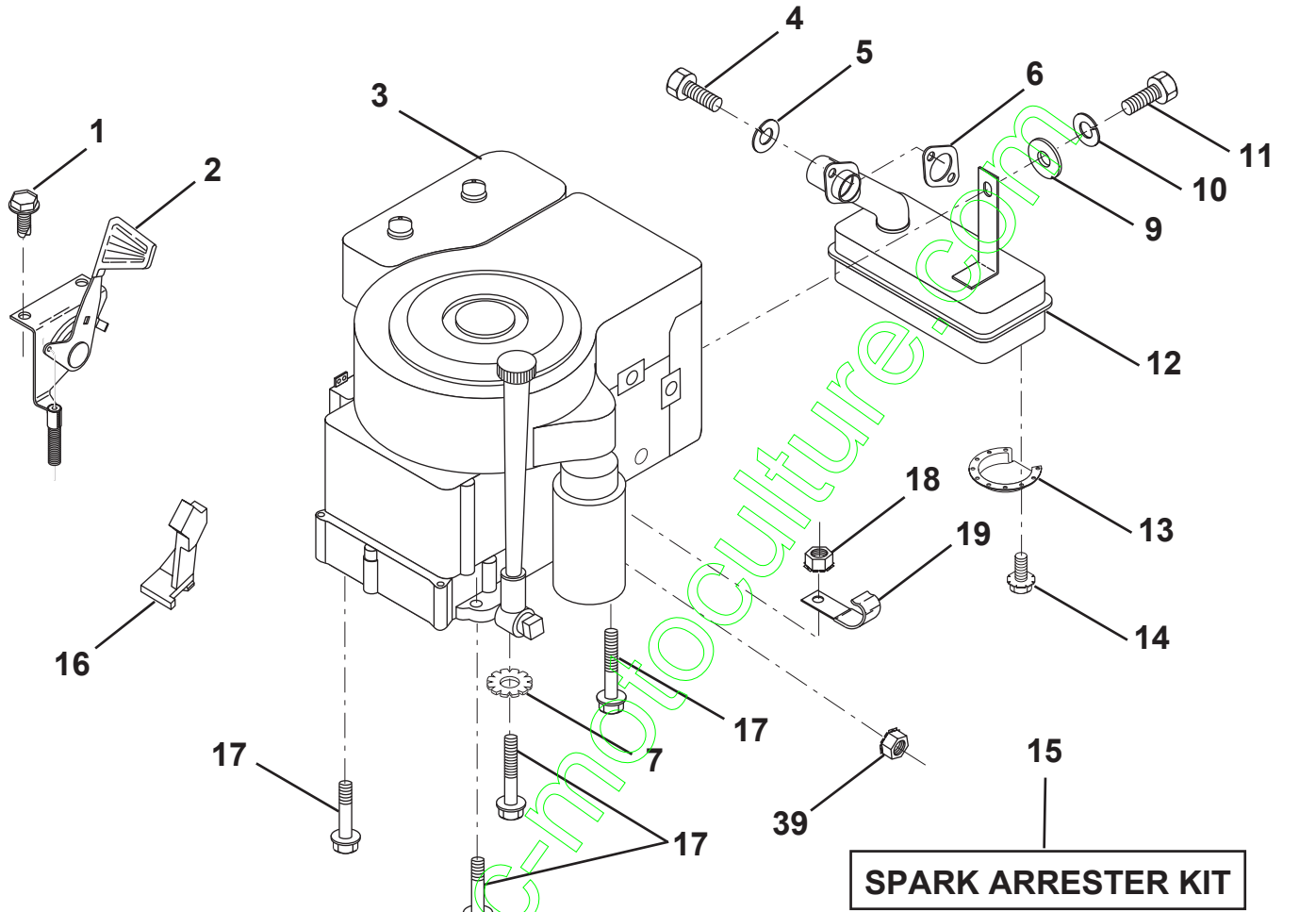

KEY NO.	PART NO.	DESCRIPTION
1	817060408	Screw, Hex Thd. Cut 1/4-20 x 1/2
2	532133025	Control, Throttle
3	-----	Engine
4	871070512	Screw, Hex, Cap 5/16-18 x 3/4
5	810040500	Washer, Lock Heavy Helical Spring 5/16
6	532272293	Gasket, Exhaust
7	811050600	Washer Lock Ext. Tooth 3/8
9	819101216	Washer 5/16 x 3/4 x 16
10	810040400	Washer, Lock Heavy Helical Spring 1/4
11	-----	Bolt, Hex Fin. (Order from Eng. Mfg.)
12	532137437	Muffler

KEY NO.	PART NO.	DESCRIPTION
13	532101326	Deflector, Muffler
14	817030808	Screw, Spiderloc
15	532137180	Arrester, Spark (Optional equipment)
16	532127951	Stop, Throttle
17	817490624	Screw, Hex Washer Head, Thdrol. 3/8-16 x 1-1/2
18	873510600	Nut, Keps Hex 3/8-16
19	532124996	Clip, Line Fuel
39	532128861	Nut, Flange 1/4-20

NOTE: All component dimensions given in U.S. inches
1 inch = 25.4 mm

HARDWARE SHOWN LARGER FOR EASIER IDENTIFICATION

G

SECTOR GEAR / AXLE SUPPORT

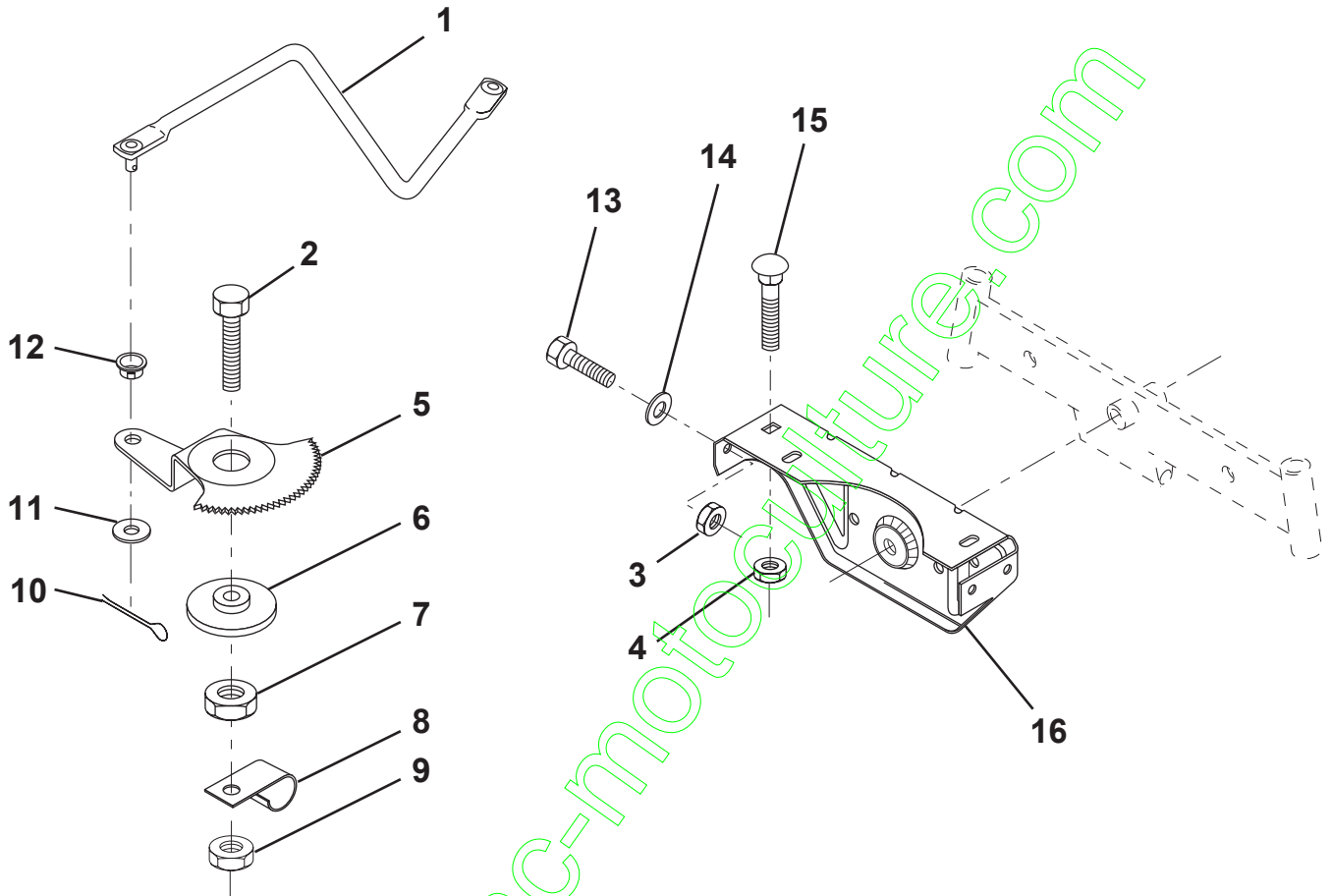

KEY NO.	PART NO.	DESCRIPTION
1	532132566	Link, Drag
2	874780828	Bolt, Fin Hex 1/2-13 x 1-3/4
3	873680500	Nut, Crownlock 5/16-18
4	873680600	Nut, Crownlock 3/8-16
5	532121926	Gear, Sector
6	532121927	Bushing
7	873030800	Nut, Heavy Hex Top Lock 1/2-13UNC
8	532126472	Clip, Insulated
9	873680800	Nut, Crownlock 3/8-16

KEY NO.	PART NO.	DESCRIPTION
10	876020412	Pin, Cotter 1/8 x 3/4
11	819131316	Washer, 13/32 x 13/16 x 16 Ga.
12	532126847	Bushing
13	874760512	Bolt, Hex Hd. 5/16-18 UNC x 3/4
14	819111416	Washer 11/32 x 7/8 x 16 Ga.
15	872110606	Bolt, Carriage 3/8-16 UNC x 3/4
16	532137096	Support, Front Axle

NOTE: All component dimensions given in U.S. inches
1 inch = 25.4 mm

HARDWARE SHOWN LARGER FOR EASIER IDENTIFICATION

H

FRONT AXLE

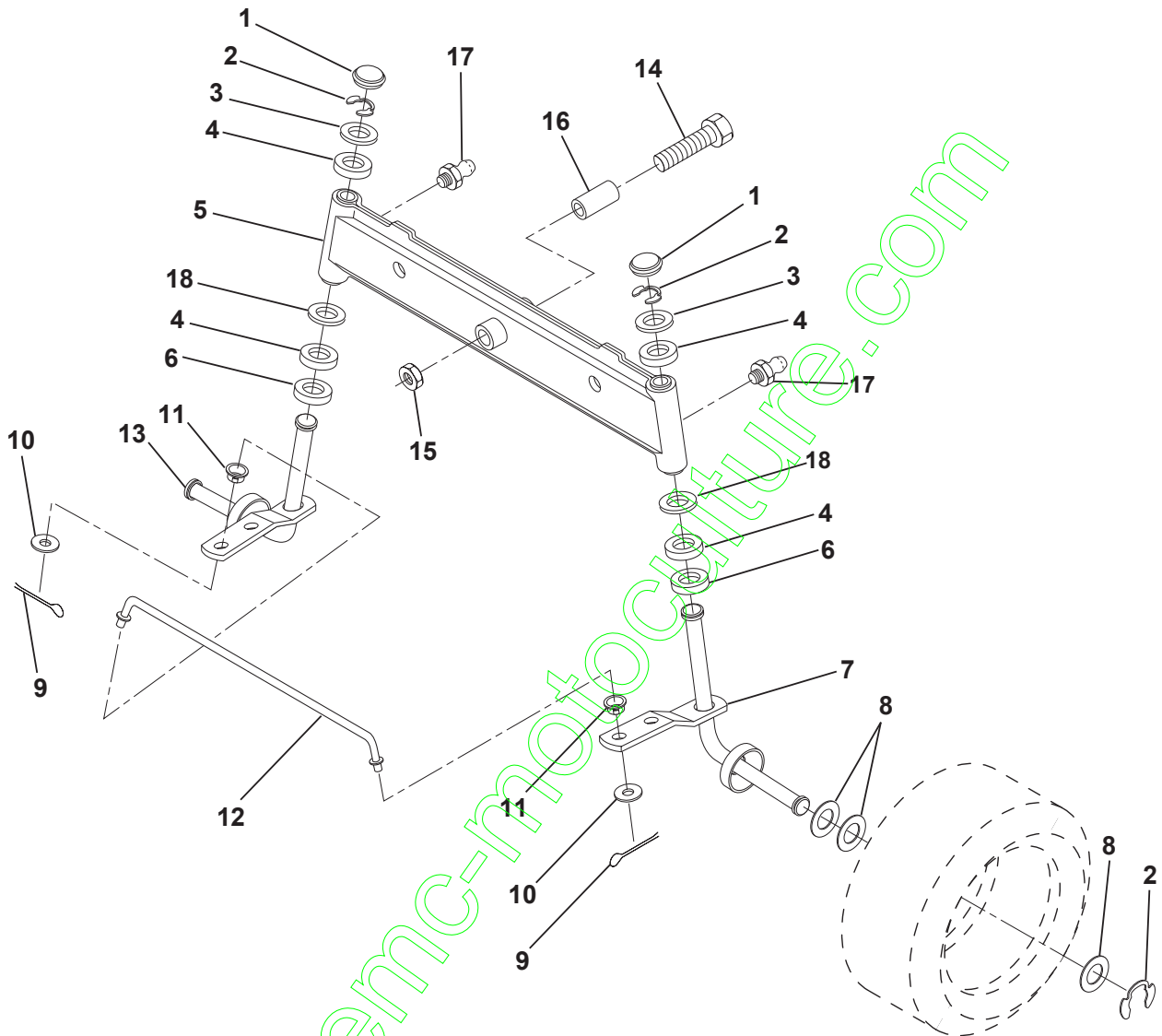

KEY NO.	PART NO.	DESCRIPTION
1	532121232	Cap, Spindle
2	812000029	Ring, Clip
3	532121748	Washer 25/32 x 1-5/8 x 16 Ga.
4	532124937	Bearing, Col Strg.
5	532142033	Axle, Front
6	532124931	Bearing, Thrust
7	532137062	Spindle, R.H. Asm.
8	532121749	Washer 25/32 x 1-1/4 x 16 Ga.
9	876020412	Pin, Cotter 1/8 x 3/4
10	819131316	Washer 13/32 x 13/16 x 16 Ga.

KEY NO.	PART NO.	DESCRIPTION
11	532126847	Bushing
12	532130465	Rod, Tie
13	532137061	Spindle, L.H. Asm.
14	874011056	Bolt, Hex 5/8-11 x 3-1/2
15	873901000	Locknut, Flange 5/8-11
16	532110438	Spacer, Bearing
17	532124836	Fitting, Grease
18	819272016	Washer 27/32 x 1-1/4 x 16 Ga.

NOTE: All component dimensions given in U.S. inches
1 inch = 25.4 mm

HARDWARE SHOWN LARGER FOR EASIER IDENTIFICATION

J

BRAKE / REAR MOWER LIFT ASSEMBLY

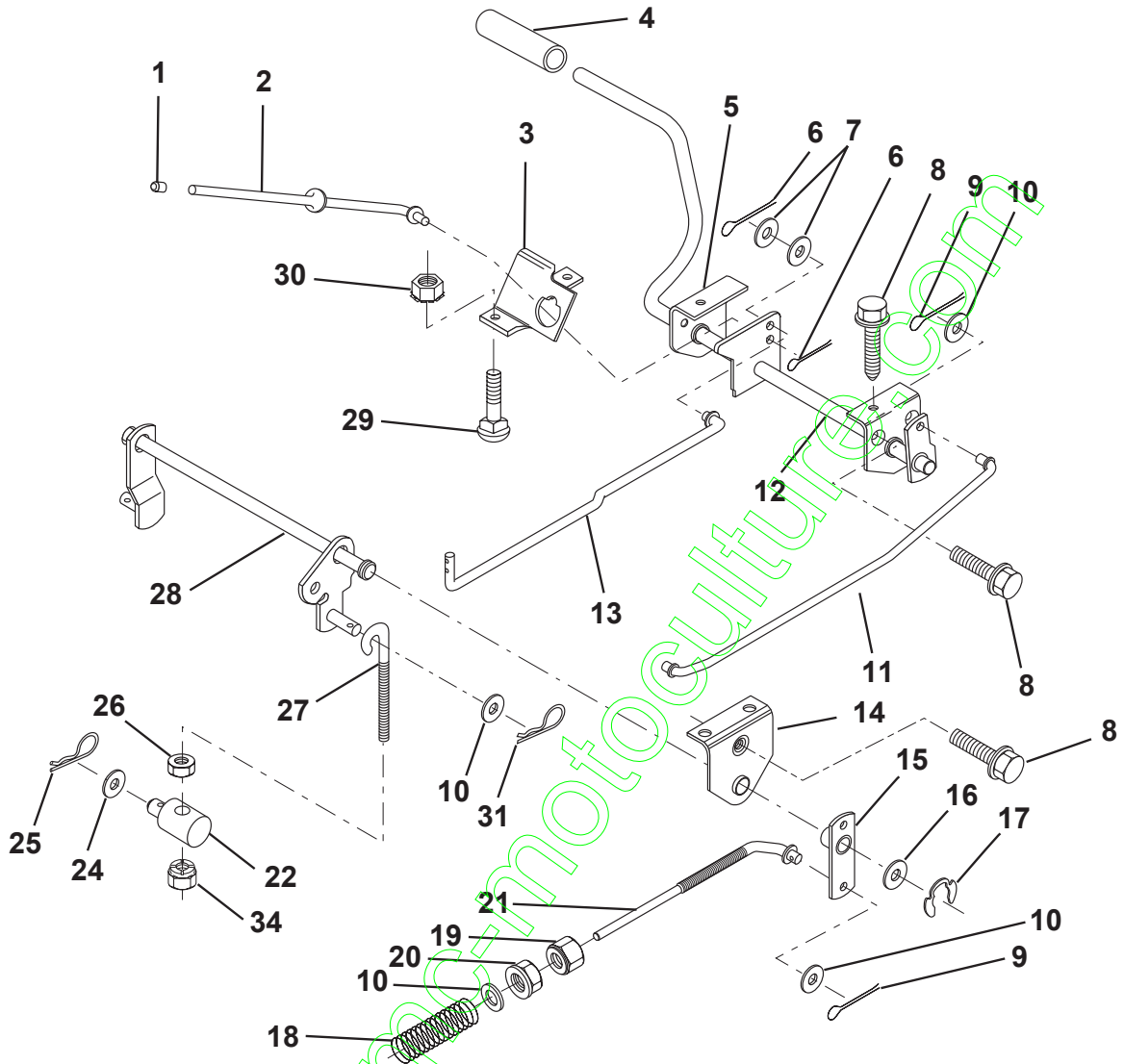

KEY NO.	PART NO.	DESCRIPTION	KEY NO.	PART NO.	DESCRIPTION
1	532071673	Cap, Plunger	17	812000034	Ring, Klip
2	532123436	Rod, Parking Brake	18	532151332	Spring, Brake Rod
3	532123437	Bracket, Parking Brake	19	873350600	Nut, Hex, Jam 3/8-16 UNC
4	532008156	Cover, Pedal	20	873800600	Nut, Lock Hex W/ns. 3/8-16
5	532122504	Bracket, Clutch/Brake Pedal, L.H.	21	532131460	Rod, Rear Brake
6	876020312	Pin, Cotter 3/32 x 3/4	22	532144585	Trunnion, Lift
7	819131016	Washer 13/32 x 5/8 x 16 Ga.	24	819132012	Washer 13/32 x 1-1/4 x 12 Ga.
8	817490508	Screw, Hex, Thd. Roll. 5/16-18 x 1/2	25	532124961	Spring, Retainer
9	876020412	Pin, Cotter 1/8 x 3/4	26	873930600	Nut, Centerlock 3/8-16 UNC
10	819131316	Washer 13/32 x 13/16 x 16 Ga.	27	532127369	Link, Threaded
11	532123543	Rod, Brake Front	28	532140776	Assembly, Rear Mower Lift
12	532139933	Assembly, Clutch/Brake Pedal	29	872110506	Bolt, Carriage 5/16-18 UNC x 3/4
13	532123394	Rod, Clutch	30	873510500	Nut, Keps 5/16-16 UNC
14	532121978	Bracket, Lift, Shaft	31	532124660	Retainer, Spring
15	532133332	Assembly, Brake, Pivot, Arm	34	873680600	Nut, Crownlock
16	819251816	Washer 25/32 x 1-1/8 x 16 Ga.			

NOTE: All component dimensions given in U.S. inches
1 inch = 25.4 mm

HARDWARE SHOWN LARGER FOR EASIER IDENTIFICATION

K

GROUND DRIVE

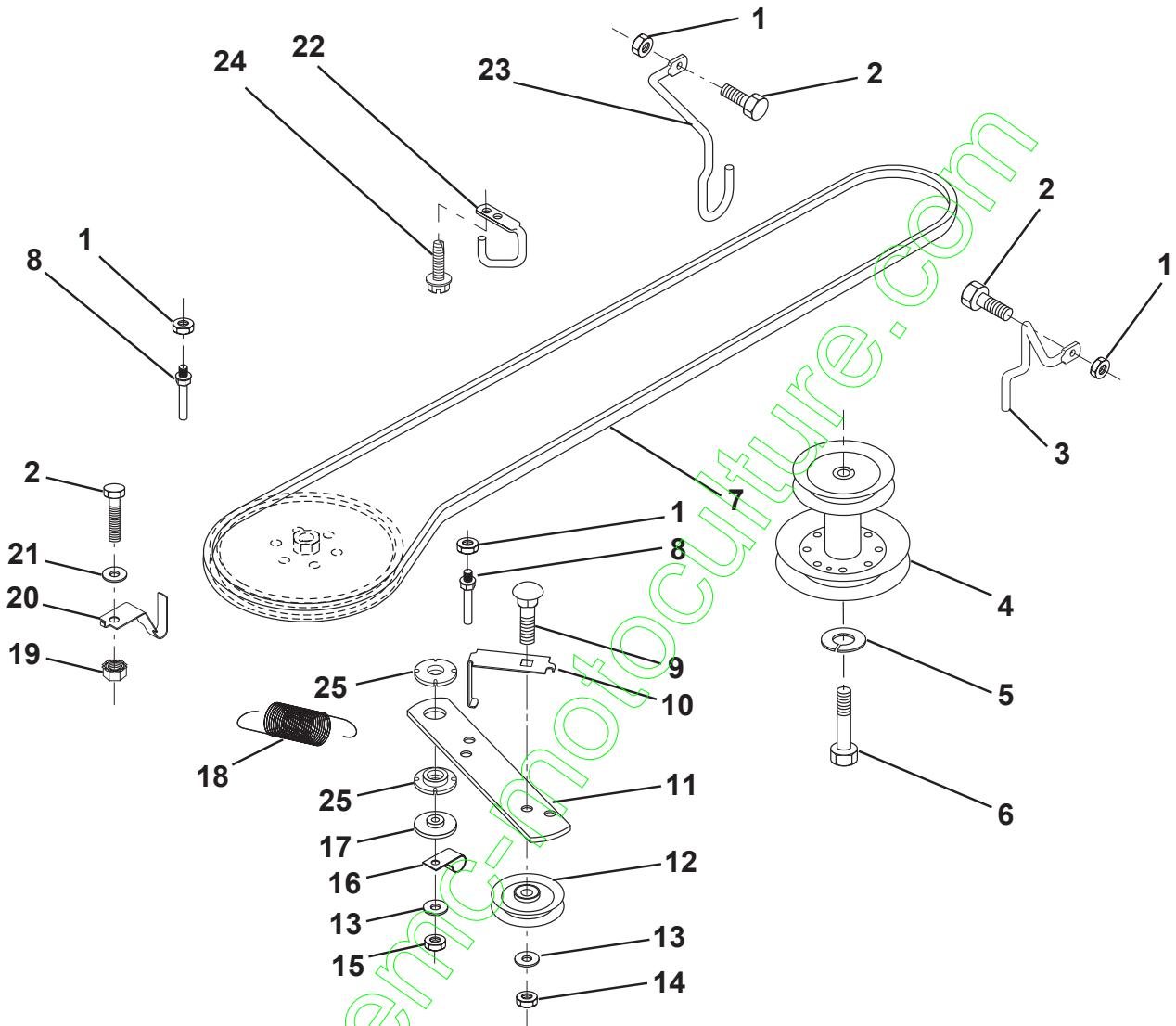

KEY NO.	PART NO.	DESCRIPTION
1	873680500	Nut Crownlock 5/16-18
2	874760512	Bolt, Hex Hd 5/16-18 UNC x 3/4
3	532141342	Keeper, Mower Drive, R. H.
4	532138029	Pulley, Engine
5	810040700	Washer, Lock 7/16
6	871170744	Bolt Hex 7/16-20 Gr. 5
7	531005025	Traction V-Belt, Drive
8	532123405	Keeper, T/A Ground Drive Belt
9	872140612	Bolt, Carr. 3/8-16 UNC x 1-1/2
10	532123396	Keeper, Belt Ground Drive Idler
11	532150926	Arm, Ground Drive Clutch
12	532123674	Idler, Flat
13	819131316	Washer 13/32 x 13/16 x 16 Ga.

KEY NO.	PART NO.	DESCRIPTION
14	873930600	Nut, Centerlock 3/8-16 Unc
15	873680600	Nut, Crownlock 3/8-16
16	532126471	Clip, Insulated
17	532150932	Spacer, Retainer
18	532131459	Spring Extension
19	873510500	Nut, Keps 5/16-18 UNC
20	532139919	Keeper, T/A Ground Drive Belt
21	819111016	Washer 11/32 x 5/8 x 16 Ga.
22	532123404	Keeper, Frame Ground Drive Belt
23	532140916	Keeper, Mower Drive, L. H.
24	817720408	Screw, Thd Cut 1/4-20 x 1/2
25	532150935	Bushing Nylon

NOTE: All component dimensions given in U.S. inches
1 inch = 25.4 mm

HARDWARE SHOWN LARGER FOR EASIER IDENTIFICATION

L

TRANSAXLE

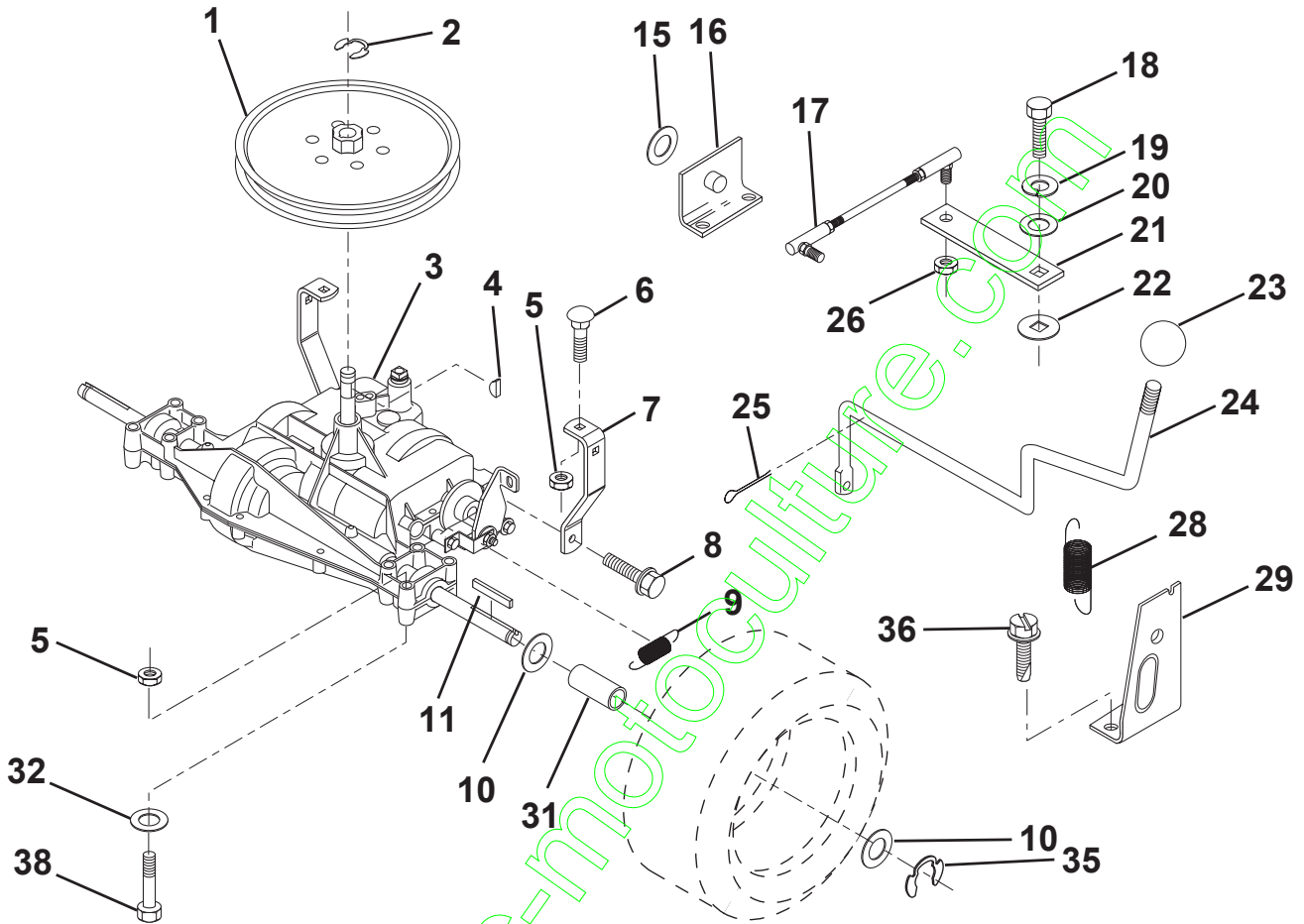

KEY NO.	PART NO.	DESCRIPTION
1	532123385	Pulley
2	812000028	Ring, Retainer
3	-----	Transaxle
4	532125096	Key, Woodruff #9
5	873680500	Nut, Crownlock 5/16-18
6	872140506	Bolt, Carriage 5/16-18 UNC x 3/4
7	532123378	Strap, Torque
8	817490512	Screw 5/16-18 x 3/4
9	532146682	Spring, Brake
10	532121749	Washer 25/32 x 1-1/4 x 16 Ga.
11	532123583	Key, Square
15	819171616	Washer 17/32 x 1 x 16 Ga.
16	532124600	Support, Handle Shift LH
17	532126293	Link, Shift
18	874550412	Bolt, Fin Hex 1/4-28 UNF x 3/4 Gr. 8
19	810040400	Washer, Lock 1/4
20	819091210	Washer 9/32 x 3/4 x 10 Ga.

KEY NO.	PART NO.	DESCRIPTION
21	532126292	Arm, Shift
22	532105701	Washer, Shift Plate
23	532121274	Knob, Duckhead
24	532128215	Rod, Shift
25	876020416	Pin, Cotter 1/8 x 1
26	873810500	Locknut 5/16-24 UNF
28	532128085	Spring, Extension
29	532128084	Support, Handle Shift RH
31	532137057	Spacer, Axle
32	819111116	Washer 11/32 x 11/16 x 16 Ga.
35	812000001	E-Ring
36	817720408	Screw, Thdcut 1/4-20 x 1/2
38	874490544	Bolt, Hex, Flngnd 5/16-18

NOTE: All component dimensions given in U.S. inches
1 inch = 25.4 mm

HARDWARE SHOWN LARGER FOR EASIER IDENTIFICATION

O

MOWERLIFTLEVER

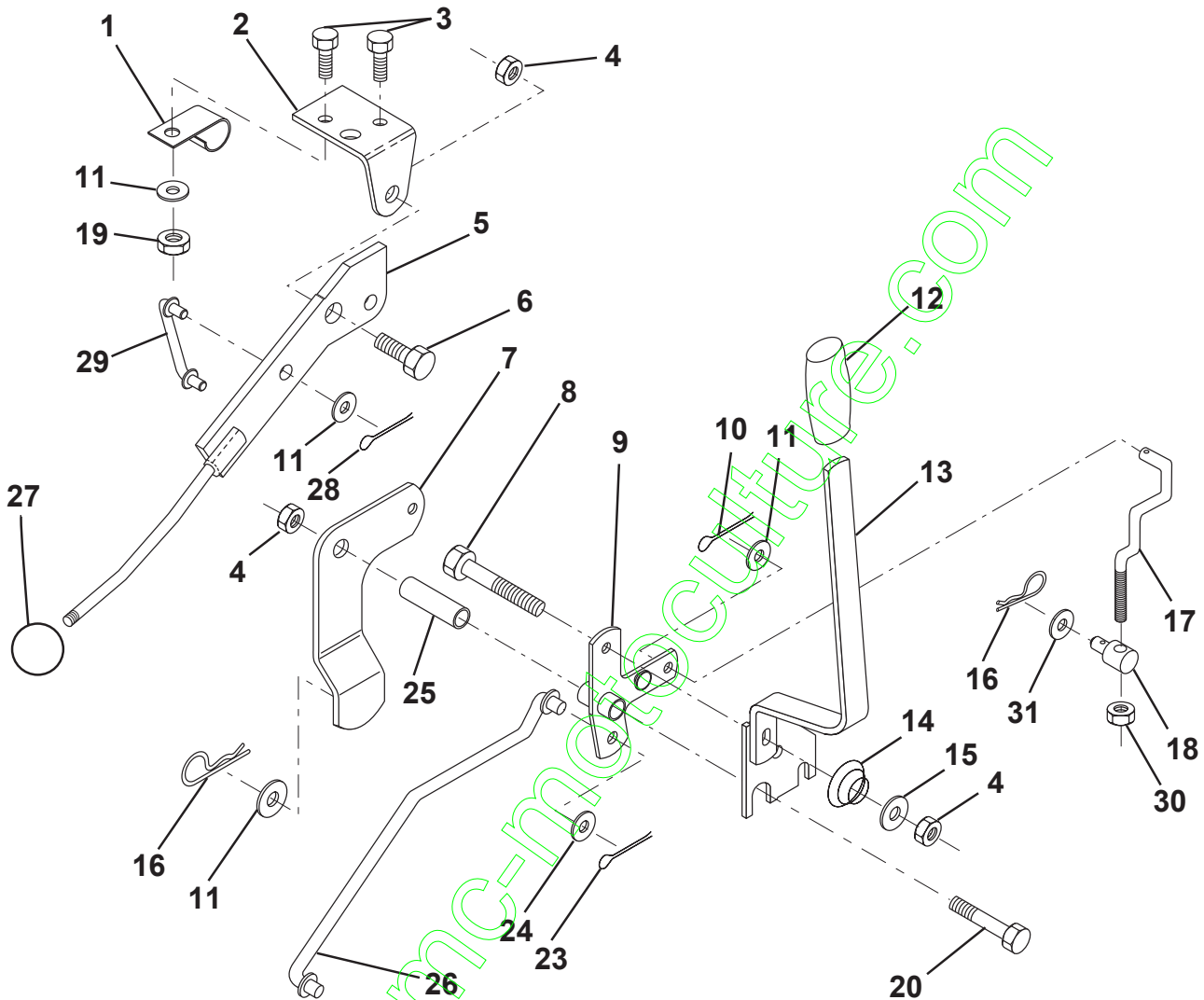

KEY NO.	PART NO.	DESCRIPTION
1	532126470	Clip, Insulated
2	532122018	Bracket, Mower Clutch
3	871110408	Bolt, Fin. Hex 1/4-20 UNC x 1/2
4	873680600	Nut, Crownlock 3/8-16 UNC
5	532145187	Assembly, Clutch Lever
6	532106451	Bolt, Shoulder
7	532135371	Assembly, Mower Clutch Arm
8	874760636	Bolt, Hex 3/8-16 UNC x 2-1/4
9	532121930	Assembly, Bellcrank Lift
10	876020412	Pin, Cotter 1/8 x 3/4
11	819131316	Washer 13/32 x 13/16 x 16 Ga.
12	532122027	Grip, Handle
13	532139352	Assembly, Lift Handle
14	532123496	Spring, Compression
15	819131212	Washer 13/32 x 3/4 x 12 Ga.
16	532124961	Retainer, Spring

KEY NO.	PART NO.	DESCRIPTION
17	532127359	Link, Front Lift
18	532142028	Trunnion, Threaded 3/8-16
19	873680400	Nut, Crownlock 1/4-20
20	874760644	Bolt, Fin. Hex 3/8-16 UNC x 2-3/4
23	876020416	Pin, Cotter 1/8 x 1
24	819171612	Washer 17/32 x 1 x 12 Ga.
25	532121933	Tube, Spacer
26	532141470	Rod, Mower Lift
27	532121466	Knob
28	876020312	Pin, Cotter 3/32 x 3/4
29	532131655	Link, Mower Clutch
30	873350600	Nut, Hex Jam 3/8-16
31	819132012	Washer 13/32 x 1-1/4 x 12 Ga.

NOTE: All component dimensions given in U.S. inches
1 inch = 25.4 mm

HARDWARE SHOWN LARGER FOR EASIER IDENTIFICATION

M

MOWERDECK

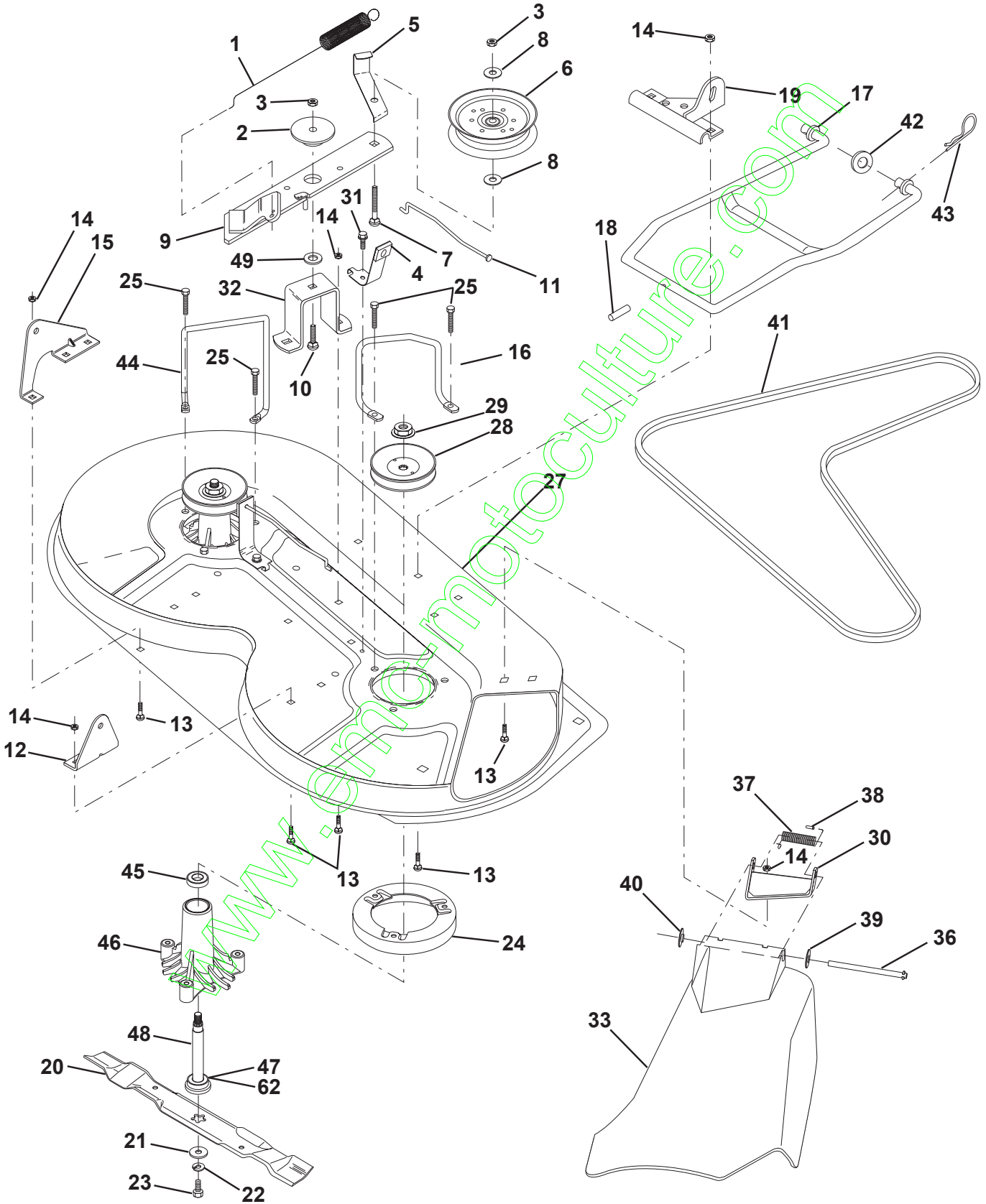

M

MOWERDECK

KEY NO.	PART NO.	DESCRIPTION	KEY NO.	PART NO.	DESCRIPTION
1	532140064	Spring, Mower Clutch	30	532136631	Bracket, Asm. Deflector
2	532122052	Spacer, Retainer	31	817490508	Screw, Hex Wsh. Thdrol. 5/16-18 x 1/2
3	873680600	Nut, Crownlock 3/8 - 16	32	532122051	Arm, Support Idler Mower
4	532130840	Brake Asm.	33	532139083	Deflector
5	532131251	Guide, Belt Idler	36	532121980	Rod, Hinge
6	532121316	Pulley, Idler Flat	37	532123713	Spring, Torsion Deflector
7	872110616	Bolt, Carr. 3/8-16 x 1-3/4 Gr. 5	38	532105304	Cap, Sleeve
8	819131410	Washer 13/21 x 7/8 x 10 Ga.	39	819111016	Washer 11/32 x 5/8 x 16 Ga.
9	532127744	Arm Asm., Idler Mower	40	532110452	Pushnut
10	872140610	Bolt, Carriage 3/8-16 x 1-1/4	41	531005026	V-Belt
11	532130841	Rod, Brake	42	819171616	Washer 11/32 x 5/8 16 Ga.
12	532127356	Bracket, Lift R. H. Rear	43	532124660	Retainer, Spring
13	872140506	Bolt, Carriage 5/16-18 x 3/4	44	532140608	Keeper, L. H.
14	873680500	Nut, Crownlock 5/16-18	45	532110485	Bearing
15	532127357	Bracket, Lift L. H. Rear	46	532128774	Housing, Mandrel Vented
16	532153298	Keeper, R. H.	47	532129895	Bearing
17	532128508	Link, Asm. Mower Stabilizer	48	532137645	Shaft, Mandrel (Includes Key No. 47)
18	532128511	Pin, Drive	49	532133943	Washer, Hardened
19	532127380	Bracket, Asm. Front	62	532153390	Washer Felt
20	531005023	Blade, High Lift	-	532130794	Mandrel Asm. (Includes Key Nos. 22-23, 26, 29 and 45-48)
21	532140296	Washer, Hardened	--	532156866	Deck, Mower Complete
22	810030600	Washer, Lock 3/8			
23	532850857	Bolt 3/8-24 x 1-1/4 Gr. 8			
24	532140329	Stripper			
25	532138776	Bolt 5/16-18 x 1-1/4			
27	532156600	Deck Assembly			
28	532153531	Pulley, Mandrel			
29	532137266	Nut, Flangelock 9/16			

NOTE: All component dimensions given in U.S. inches
1 inch = 25.4 mm

HARDWARE SHOWN LARGER FOR EASIER IDENTIFICATION

R

DECALS

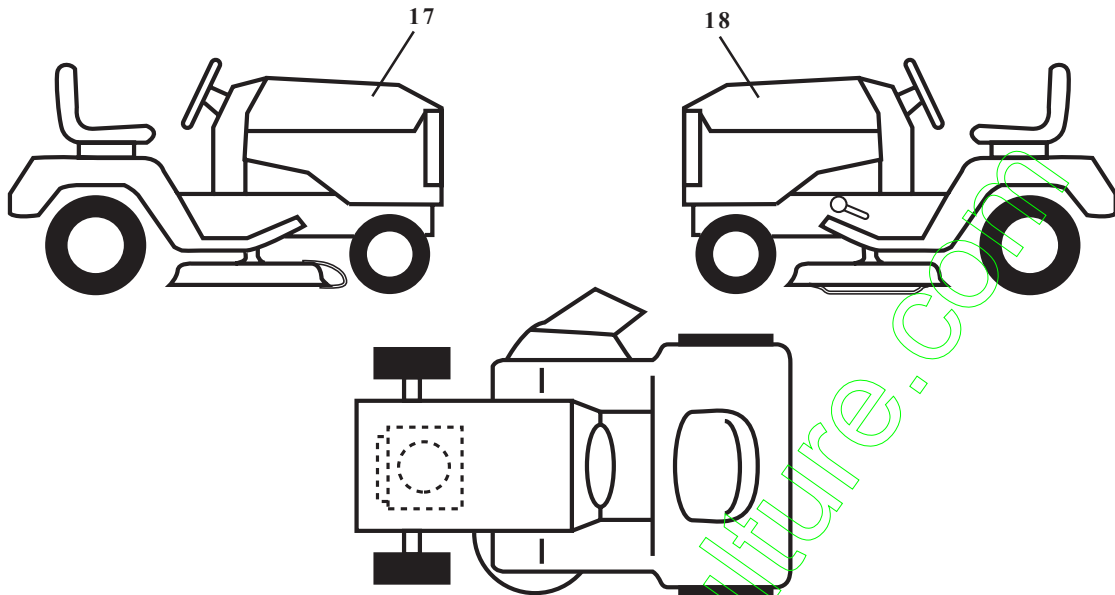

KEY NO.	PART NO.	DESCRIPTION
17	532151986	Decal, Hood LT130
18	532151987	Decal, Hood LT130

R

WHEELS & TIRES

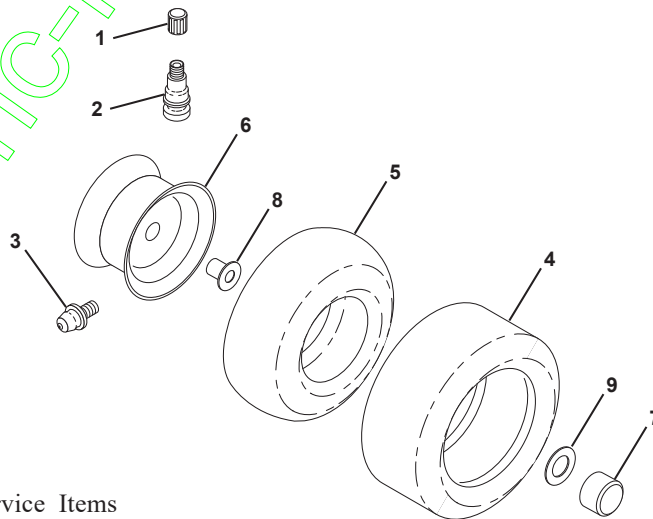

KEY NO.	PART NO.	DESCRIPTION
1	532059192	Cap, Valve
2	532065139	Stem, Valve
3	532124957	Fitting, Grease\ (Front Wheels Only)
4	532137422	Tire, Front
4	532132703	Tire, Rear
5	532059904	Tube, Front (Optional Service Items Only)
5	532008134	Tube, Rear (Optional Service Items Only)
6	532142039	Rim, Front
6	532141652	Rim, Rear
7	532104757	Cap, Hub
8	532124959	Bearing Flange
9	532121748	Washer 25/32 x 1-5/8 x 16 Ga.

NOTE: All component dimensions given in U.S. inches