

LT16 A

Spare parts
Ersatzteile
Pièces détachées
Reserve onderdelen
Repuestos
Reservdelar

www.emc-motoculture.com

TRACTOR - MODEL NO. LT16A (JLT16H42A), PRODUCT NO. 954 13 00-61 SCHEMATIC

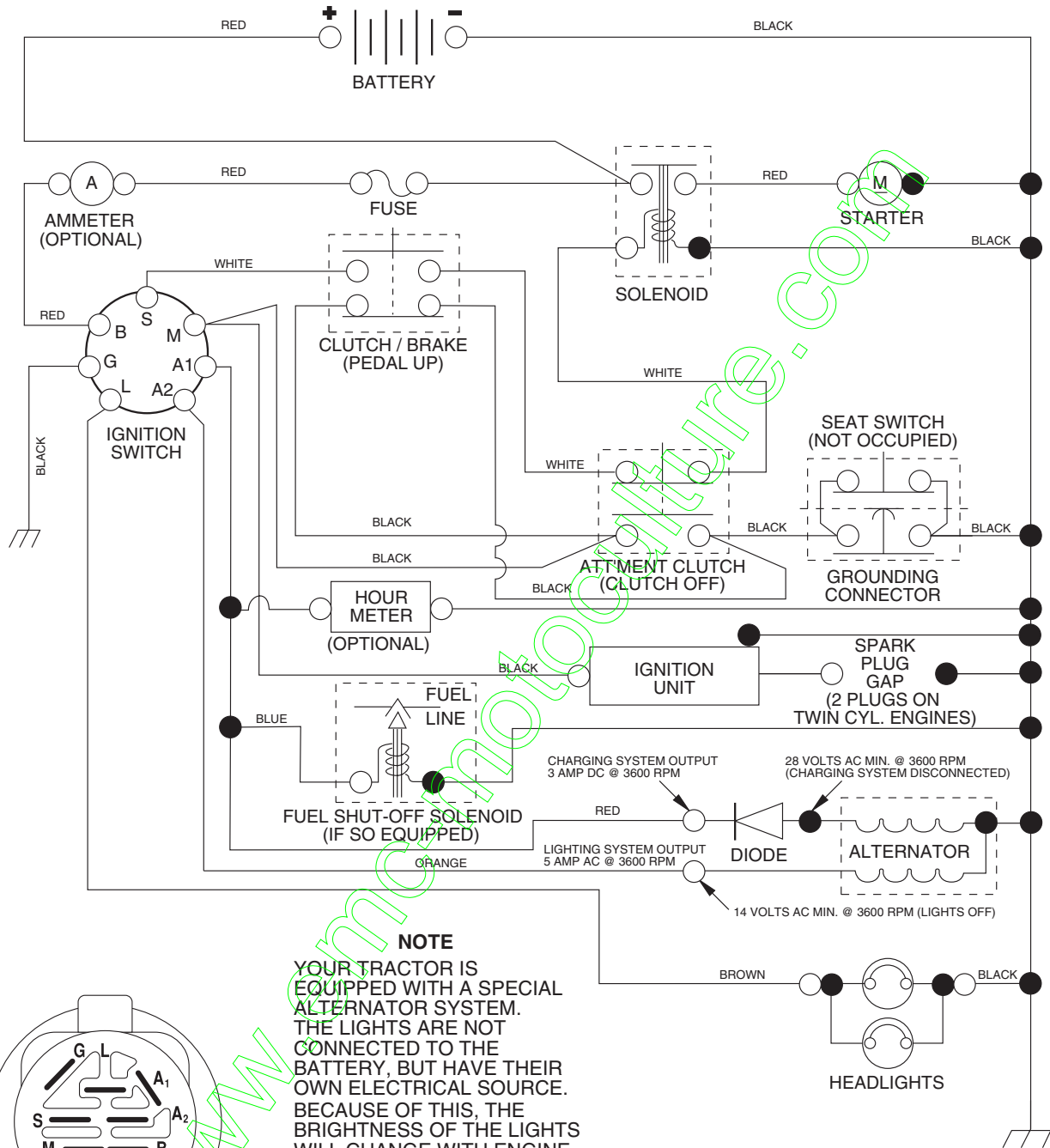

NOTE

YOUR TRACTOR IS EQUIPPED WITH A SPECIAL ALTERNATOR SYSTEM. THE LIGHTS ARE NOT CONNECTED TO THE BATTERY, BUT HAVE THEIR OWN ELECTRICAL SOURCE. BECAUSE OF THIS, THE BRIGHTNESS OF THE LIGHTS WILL CHANGE WITH ENGINE SPEED. AT IDLE THE LIGHTS WILL DIM. AS THE ENGINE IS SPEEDED UP, THE LIGHTS WILL BECOME THEIR BRIGHTEST.

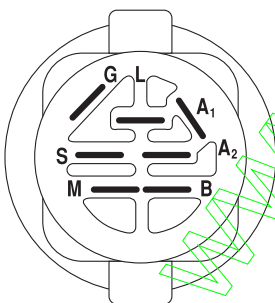

IGNITION SWITCH

POSITION	CIRCUIT	"MAKE"
OFF	M+G+A1	NONE
RUN/LIGHT	B+A1	A2+L
RUN	B+A1	NONE
START	B + S + A1	NONE

WIRING INSULATED CLIPS

NOTE: IF WIRING INSULATED CLIPS WERE REMOVED FOR SERVICING OF UNIT, THEY SHOULD BE REPLACED TO PROPERLY SECURE YOUR WIRING.

NON-REMOVABLE CONNECTIONS

REMOVABLE CONNECTIONS

REPAIR PARTS

TRACTOR - MODEL NO. LT16A (JLT16H42A), PRODUCT NO. 954 13 00-61
ELECTRICAL

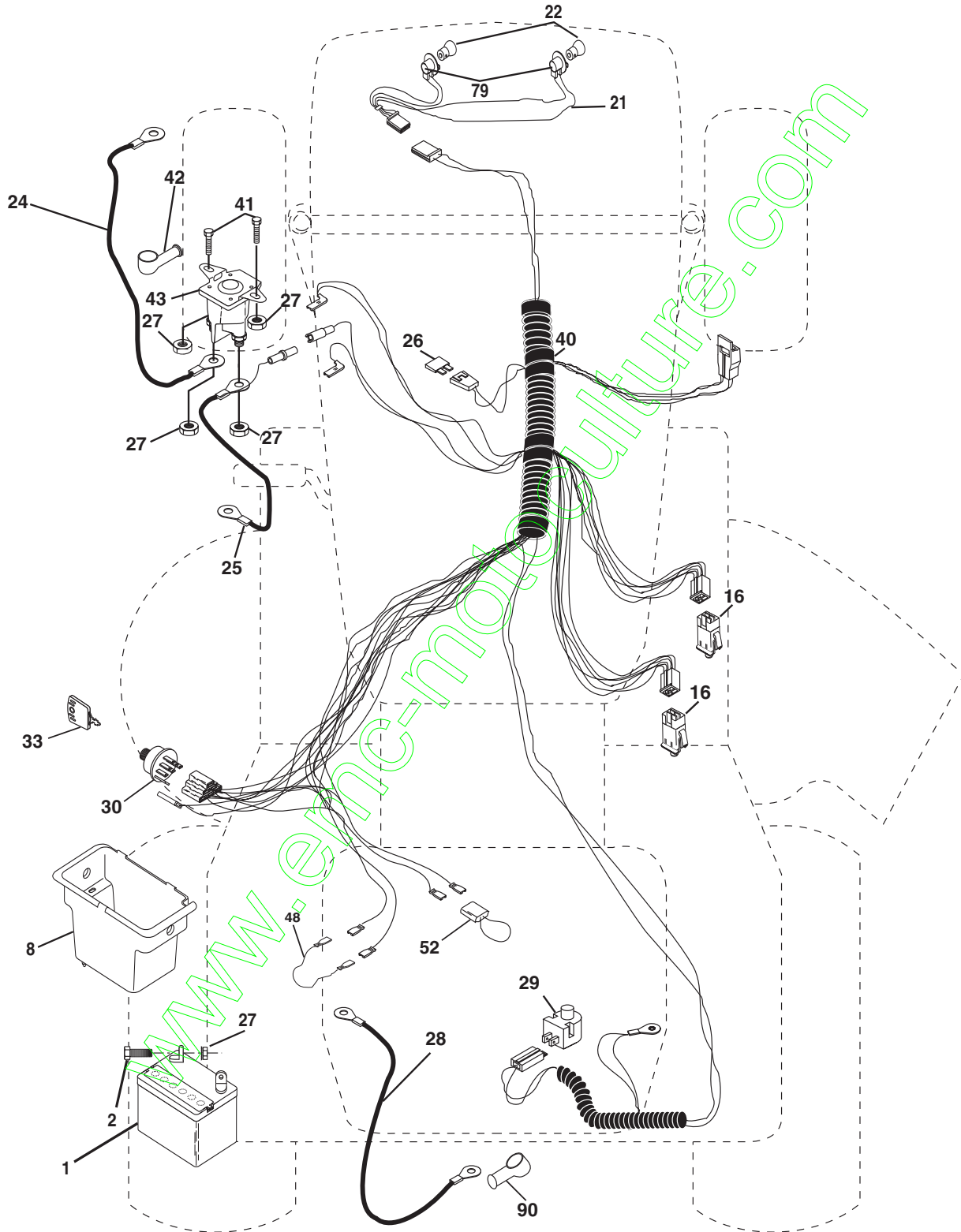

REPAIR PARTS

TRACTOR - MODEL NO. LT16A (JLT16H42A), PRODUCT NO. 954 13 00-61
ELECTRICAL

KEY NO.	PART NO.	DESCRIPTION
1	532 1634-65	Battery 12 Volt 28 AMP
2	874 7604-12	Bolt Hex Hd 1/4-20unc X 3/4
8	532 1766-89	Case Battery Mech Hinge
16	532 1761-38	Switch Interlock Push-In
21	532 1756-88	Harness Asm Light W/4152]
22	532 0041-52	Bulb Light #1156
24	532 1247-80	Cable Battery 6 Ga 11" red
25	532 1461-47	Cable Battery 6 Ga 44" red w/16 wire
26	532 1751-58	Fuse
27	873 5104-00	Nut Keps Hex 1/4-20 Unc
28	532 1247-73	Cable Ground 6 Ga 12" black
29	532 1213-05	Switch Plunger Nc Gray
30	532 1755-66	Switch Ign
33	532 1404-01	Key Ign Molded Generic
40	532 1797-20	Harness Ign.
41	871 1104-08	Bolt Blk Fin Hex 1/4 - 20 x 1/2
42	532 1315-63	Cover Terminal Red
43	532 1788-61	Solenoid
48	532 1408-44	Adapter Ammeter Rectangular
52	532 1419-40	Protection Wire Loop
89	532 1804-49	Cover Terminal Battery

NOTE: All component dimensions given in U.S. inches.
1 inch = 25.4 mm.

REPAIR PARTS

TRACTOR - MODEL NO. LT16A (JLT16H42A), PRODUCT NO. 954 13 00-61
CHASSIS AND ENCLOSURES

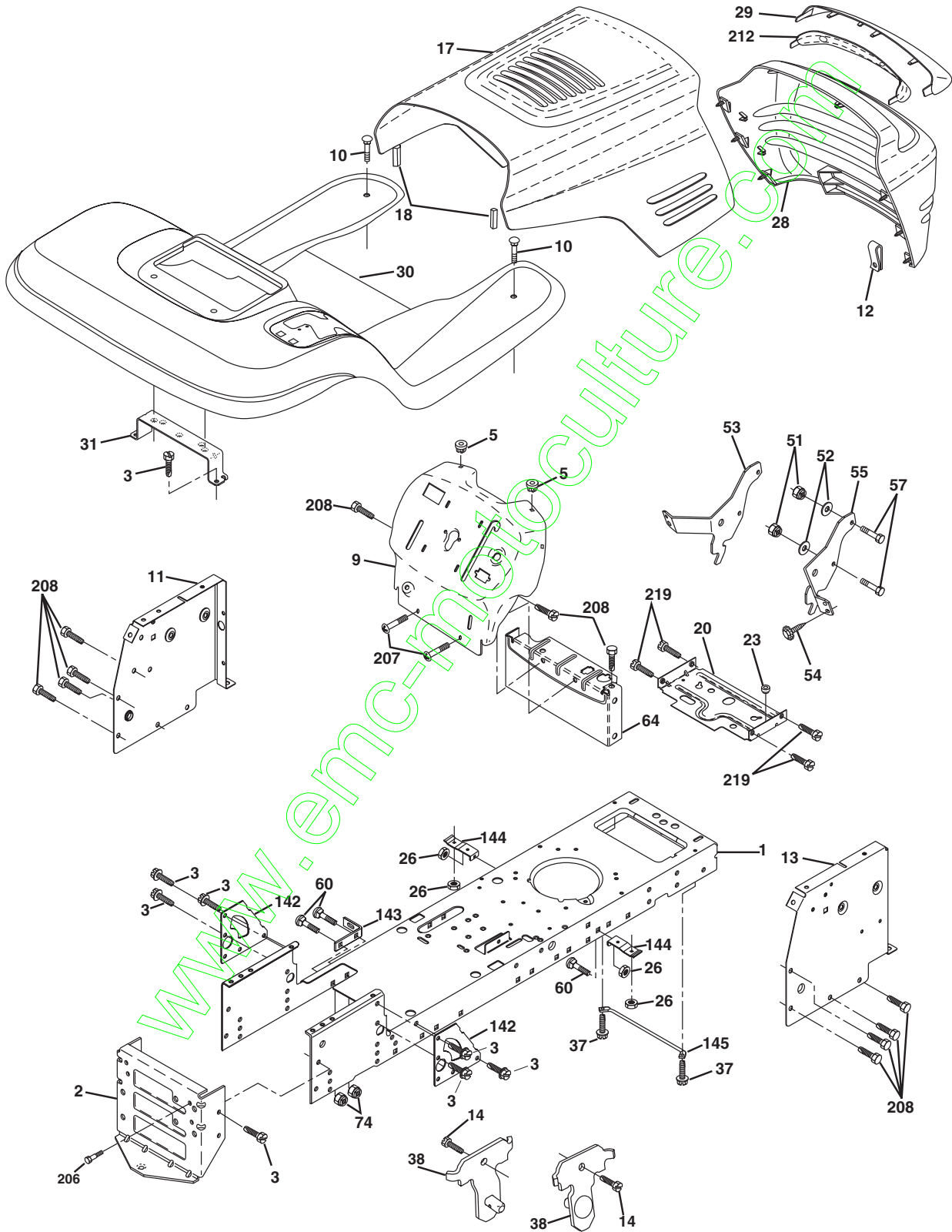

REPAIR PARTS

TRACTOR - MODEL NO. LT16A (JLT16H42A), PRODUCT NO. 954 13 00-61
CHASSIS AND ENCLOSURES

KEY NO.	PART NO.	DESCRIPTION
1	532 17 46-19	Chassis
2	532 17 65-54	Drawbar
3	817 06 06-12	Screw 3/8-16x3/4
5	532 15 52-72	Bumper Hood/Dash
9	532 17 21-51	Dash P/L
10	872 14 06-08	Bolt Carriage 3/8-16 x 1
11	532 17 49-96	Panel Dash Lh
12	532 14 56-60	Clip Tinnerman Grille P/L
13	532 17 21-06	Panel Dash Rh
14	817 49 06-08	Screw Thdrol 3/8-16 x 1/2
17	532 15 07-60	Hood LT/PL with Louvers
18	532 16 46-55	Bumper Hood
20	532 18 06-79	Plate Mtg Battery Fuel Tank Fr
23	532 12 40-28	Bushing
26	873 80 06-00	Nut Lock Hex W/Ins 3/8-16 UNC
28	532 17 93-51	Grille/Lens Asm
29	532 17 90-14	Lens LT/PL Grille Shark Plain
30	532 18 12-05	Fender Footrest
31	532 13 99-76	Bracket Support Fender
37	817 49 05-08	Screw Thdrol 6/16-18 x 1/2 TYT
38	532 17 57-10	Bracket Asm Pivot Mower Rear
51	873 80 04-00	Nut Lock Hex W/Ins 1/4-20
52	819 09 14-16	Washer 9/32 x 7/8 x 16 Ga.
53	532 14 52-01	Bracket Pnt. Pickoff LH
54	532 16 14-64	Screw Hex Wshd 8-18 x 7/8
55	532 14 52-02	Bracket Grille Pickoff RH
57	874 78 04-12	Bolt Hex 1/4-20 x 3/4
60	872 14 06-06	Bolt Rdhd Sqnk 3/8-16unc x 3/4
64	532 15 47-98	Dash Lower STLT
74	873 68 06-00	Nut Crownlock 3/8-16 UNC
142	532 17 57-02	Plate Reinforcement STLT
143	532 15 49-66	Bracket Swaybar Chassis
144	532 17 55-82	Bracket Pnt Footrest STLT
145	532 15 65-24	Rod Pivot Chassis/Hood
206	532 17 01-65	Bolt Shoulder 5/16-18 TT
207	817 67 05-08	Screw Thdrol 5/16-18 x 1/2 TY TT
208	817 67 06-08	Screw Thdrol 3/8-16 x 1/2 TY TT
212	532 16 59-19	Insert Lens Reflective
219	817 00 05-12	Screw 5/16-18 x 3/4
-	532 00 54-79	Plug Button

NOTE: All component dimensions given in U.S. inches
1 inch = 25.4 mm

REPAIR PARTS

TRACTOR - MODEL NO. LT16A (JLT16H42A), PRODUCT NO. 954 13 00-61
DRIVE

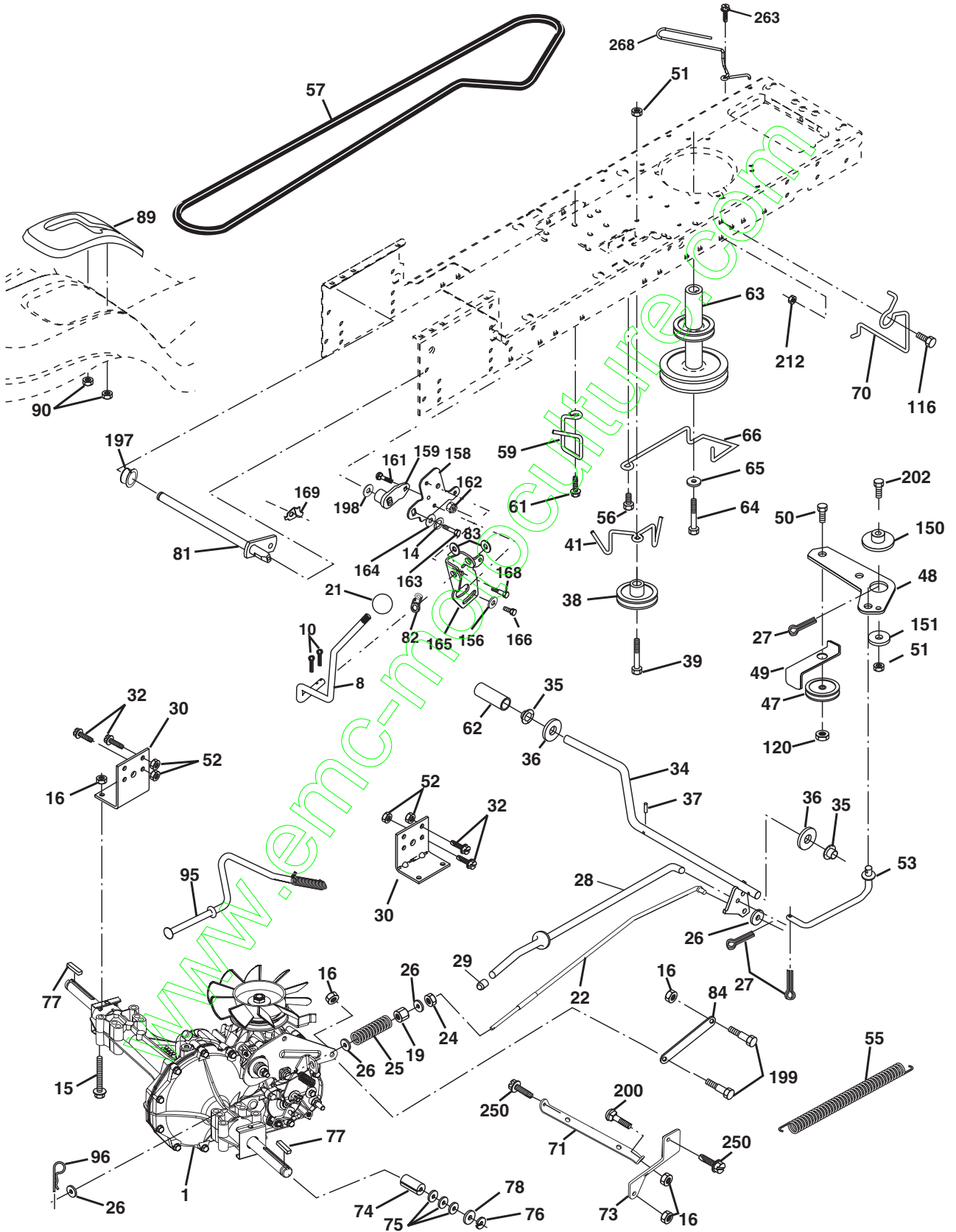

REPAIR PARTS

TRACTOR - MODEL NO. LT16A (JLT16H42A), PRODUCT NO. 954 13 00-61 DRIVE

KEY NO.	PART NO.	DESCRIPTION	KEY NO.	PART NO.	DESCRIPTION
1	-----	Transaxle Hydro Gear 314-0510 Order parts from transaxle manufacturer	66	532 15 47-78	Keeper Belt Engine
8	532 16 58-66	Rod Shift Fender Adjust Lt	70	532 18 02-18	Keeper Belt Engine
10	876 02 04-16	Pin Cotter 1/8 x 1 CAD	71	532 16 91-83	Strap Torque Lh Hydro
14	810 04 04-00	Washer Lock Hvy Helical	73	532 16 91-82	Strap Torque Rh Hydro
15	874 49 05-44	Bolt Fin Hex 5/16-18 x Gr. 5	74	532 13 70-57	Spacer, Axle
16	873 80 05-00	Nut Lock Hex W/Ins 5/16-18	75	532 12 17-49	Washer 25/32 x 1-1/4 x 16 Gauge
19	873 80 06-00	Nut Lock Hex W/Wsh 3/8-16 Unc	76	812 00 00-01	E-Ring
21	532 13 05-64	Knob 1/2-13	77	532 12 35-83	Key, Square
22	532 16 94-98	Rod, Brake Hydro	78	532 12 17-48	Washer 25/32 x 1-5/8 x 16 Gauge
24	873 35 06-00	Nut	81	532 16 55-96	Shaft Asm. Cross Tapered
25	532 10 68-88	Spring, Brake Rod	82	532 16 57-11	Spring Torsion T/A
26	819 13 13-16	Washer	83	819 17 12-16	Washer 17/32 x 3/4 x 16 Ga.
27	876 02 04-12	Pin Cotter 1/8 x 3/4 CAD.	84	532 16 95-94	Link Transaxle
28	532 17 57-65	Rod, Parking Brake	89	532 16 66-02	Console, Shift
29	532 07 16-73	Cap, Parking Brake	90	532 12 43-46	Nut Self-thd Wsh-hd 1/4 Zinc
30	532 16 95-92	Bracket, Transaxle	95	532 17 02-01	Control Asm Bypass Hydro
32	874 76 05-12	Bolt Hex Hd 5/16-18 Unc x 3/4	96	532 12 47-88	Retainer Spring 1" Zinc/Cad
34	532 17 55-78	Shaft, Foot Pedal	116	872 14 06-08	Bolt Rdhd Sq Neck 3/8-16 x 1
35	532 12 01-83	Bearing, Nylon	120	873 90 06-00	Nut Lock Flg 3/8-16
36	819 21 16-16	Washer	150	532 17 54-56	Spacer Retainer
37	532 12 49-63	Pin, Roll	151	819 13 32-10	Washer 13/32 x 2 10 Ga.
38	532 17 91-14	Pulley, Composite, Flat	156	532 16 60-02	Washer Srted 5/16 ID x 1.125
39	874 76 06-48	Bolt	158	532 16 55-89	Bracket Shift Mount
41	532 17 55-56	Keeper, Belt Idler	159	532 16 54-94	Hub Tapered Flange Shift Lt
47	532 12 77-83	Pulley, Idler, V-Groove	161	872 14 04-06	Bolt Rdhd Sqnk 1/4-20 x 3/4 Gr 5
48	532 15 44-07	Bellcrank Clutch Grnd Drv STL	162	873 68 04-00	Nut Crownlock 1/4-20 Unc
49	532 12 32-05	Retainer, Belt	163	874 78 04-16	Bolt Hex Fin 1/4-20 Unc x 1 Gr 5
50	872 11 06-12	Bolt	164	819 09 10-10	Washer 5/8 x .281 x 10 Ga
51	873 68 06-00	Nut	165	532 16 56-23	Bracket Pivot Lever
52	873 68 05-00	Nut Crownlock 5/16-18 UNC	166	532 16 68-80	Screw 5/16-18 x 5/8
53	532 10 57-10	Link, Clutch	168	532 16 54-92	Bolt Shoulder 5/16-18 x .561
55	532 10 57-09	Spring, Return, Clutch	169	532 16 55-80	Plate Fastening Lt
56	817 06 06-20	Screw 3/8-16 x 1	197	532 16 96-13	Nyliner Snap-In 5/8" ID
57	532 14 02-94	V-Belt, Ground Drive	198	532 16 95-93	Washer Nyl 7/8 ID x .105" Hyd
59	532 16 96-91	Keeper, Center Span	199	532 16 96-12	Bolt Shoulder 5/16-18 Unc
61	817 12 06-14	Screw 3/8-16 x 3/4	200	872 14 05-08	Bolt Rdhd Sqnk 5/16-18 Unc x 1
62	532 12 48-72	Cover, Pedal	202	872 11 06-14	Bolt Carr Sh 3/8-16 x 1-3/4
63	532 18 02-19	Pulley, Engine	212	532 14 52-12	Nut Hex Flg Lock
64	871 17 07-64	Bolt, Hex	250	817 06 06-12	Screw 3/8-16 x .75 SMGML Tap R2
65	810 04 07-00	Washer	263	817 00 06-12	Screw 3/8-16 x 3/4
			268	532 18 24-02	Guard Muffler

NOTE: All component dimensions given in U.S. inches
1 inch = 25.4 mm

REPAIR PARTS

TRACTOR - MODEL NO. LT16A (JLT16H42A), PRODUCT NO. 954 13 00-61
STEERING ASSEMBLY

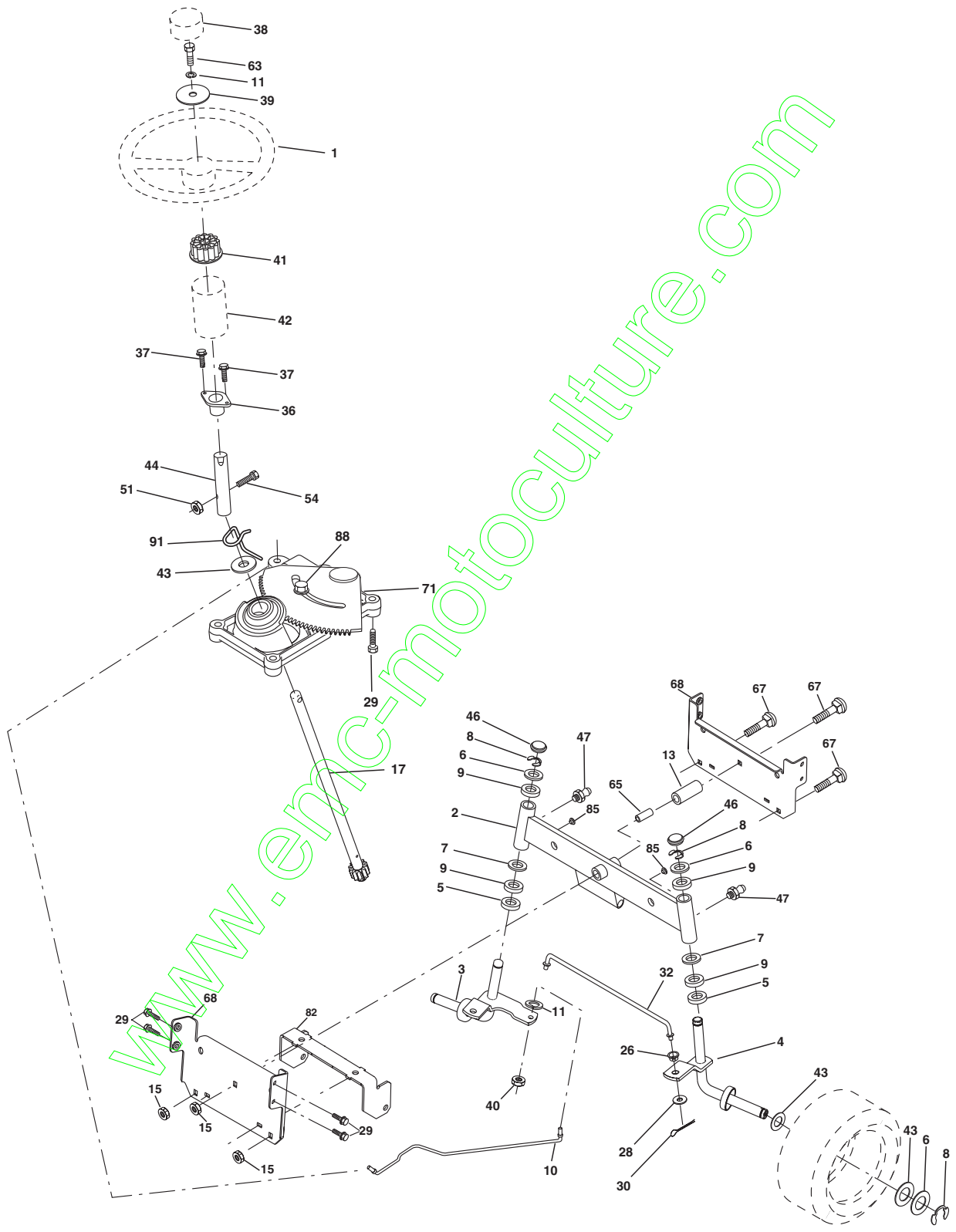

REPAIR PARTS

TRACTOR - MODEL NO. LT16A (JLT16H42A), PRODUCT NO. 954 13 00-61
STEERING ASSEMBLY

KEY NO.	PART NO.	DESCRIPTION
1	532 17 20-92	Wheel Steering
2	532 17 51-31	Axle Asm STMP Dropped STL
3	532 16 98-40	Spindle Asm LH
4	532 16 98-39	Spindle Asm RH
5	532 12 49-31	Bearing Race Thrust Harden
6	532 12 17-48	Washer 25/32 X 1-5/8 X 16 Ga
7	819 27 20-16	Washer 27/32 X 1-1/4 X 16 Ga
8	812 00 00-29	Ring Klip #15304-75
9	532 12 49-37	Bearing Col Strg Blk
10	532 17 51-21	Link Drag
11	810 04 06-00	Washer Lock Hvy Hlcl Spr 3/8
13	532 13 65-18	Spacer Brg Axle Front
15	532 14 52-12	Nut Hex Flange Lock
17	532 17 78-76	Shaft Asm Strg
26	532 12 68-47	Bushing Link Drag
28	819 13 14-16	Washer 13/32 X 7/8 X 16ga.
29	817 06 06-12	Screw 3/8-16x3/4
30	876 02 04-12	Pin Cotter 1/8 X 3/4 Cad.
32	532 13 04-65	Rod Tie
36	532 15 50-99	Bushing Strg
37	532 15 29-27	Screw
38	532 17 20-93	Insert Cap Strg Wh
39	819 13 24-11	Washer 13/32 X 1-1/20 x 11 Ga
40	532 12 47-01	Lock nut
41	532 15 99-45	Adaptor Wheel Strg
42	532 16 96-33	Boot Steering Shaft
43	532 12 17-49	Washer 25/32 X 1 1/4 X 16 Ga
44	532 15 37-20	Extension Steering Shaft LR/LT
46	532 12 12-32	Cap Spindle Fr Top Blk
47	532 18 32-26	Fitting Grease
51	873 80 05-00	Nut Lock Hex w/Ins 5/16-18
54	874 78 05-20	Bolt Fin Hex 5/16-18 Unc x 1-1/4
63	874 78 06-16	Bolt Fin Hex 3/8-16unc x 1 Gr. 5
65	532 16 03-67	Spacer Brace Axle
67	872 14 06-18	Bolt Rdhd Sq 3/8-16 x 2-1/4
68	532 16 98-27	Axle, Brace
71	532 17 51-46	Steering Asm
82	532 16 98-35	Bracket Susp Chassis Front
85	532 13 38-35	Fastner Christmas Tree
88	532 17 51-18	Bolt Shoulder 7/16-20
91	532 17 55-53	Clip Steering

NOTE: All component dimensions given in U.S. inches.
1 inch = 25.4 mm.

REPAIR PARTS

TRACTOR - MODEL NO. LT16A (JLT16H42A), PRODUCT NO. 954 13 00-61
ENGINE

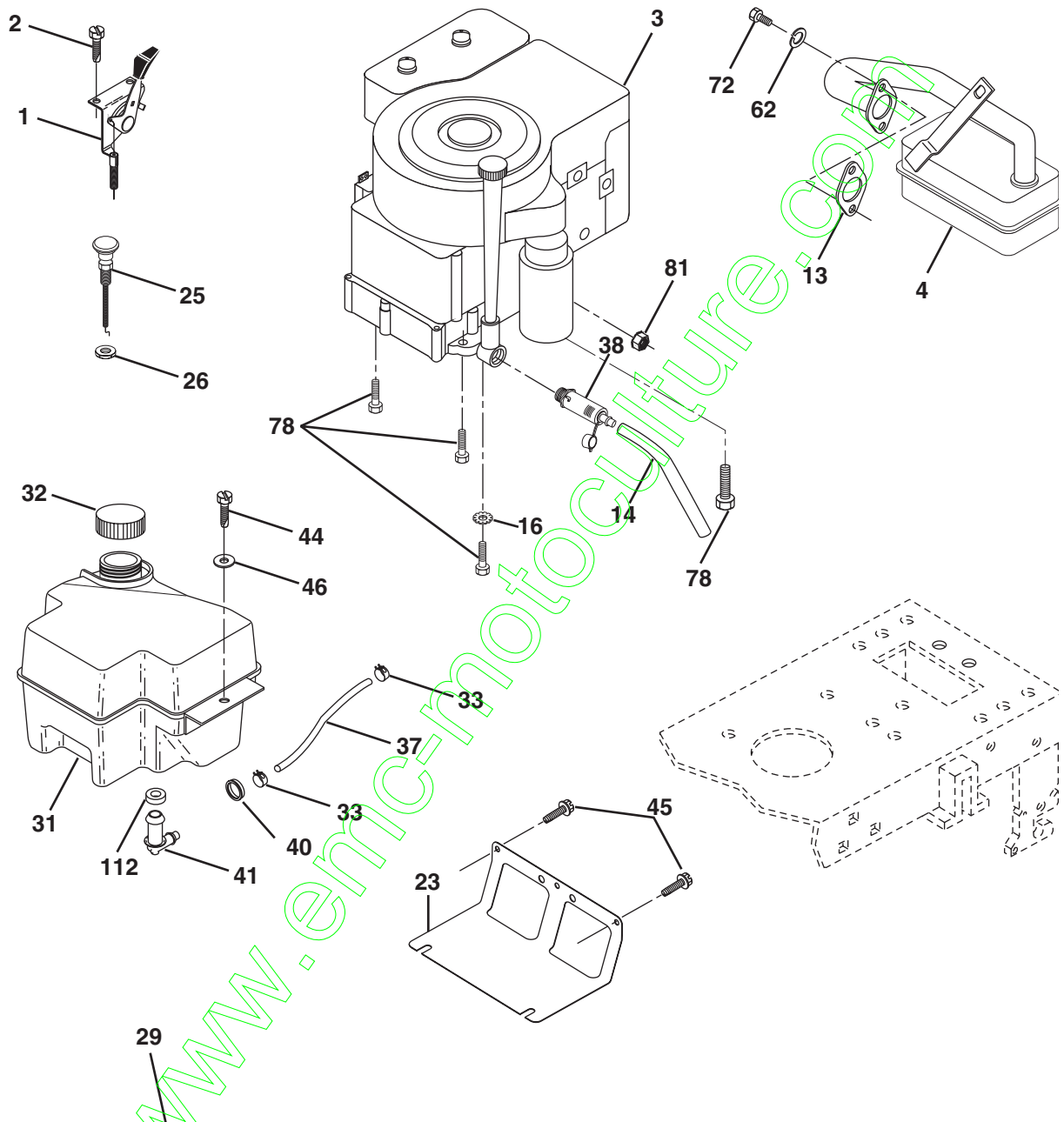

OPTIONAL EQUIPMENT
Spark Arrester

REPAIR PARTS

TRACTOR - MODEL NO. LT16A (JLT16H42A), PRODUCT NO. 954 13 00-61
ENGINE

KEY NO.	PART NO.	DESCRIPTION
1	532 17 05-51	Control Th/ch B&S EEC Flag
2	817 72 04-08	Screw Hex Thd Cut 1/4-20 x 5/8 T
3	-----	Engine B&S Model No. 31G777 Order parts from engine manufacturer
4	532 13 73-52	Muffler LT B&S
13	532 16 52-91	Gasket
14	532 14 84-56	Tube Drain Oil Easy
16	811 05 06-00	Washer Lock Ext Tooth 3/8
23	532 16 98-37	Shield Brn/Dbr Guard
25	532 18 09-45	Control Choke 1 Cyl .02
26	873 92 06-00	Nut Keps 3/8-24 Unf
29	532 13 71-80	Kit Spark Arrestor (Flat Scrn)
31	532 18 06-45	Tank Fuel Front 2 00
32	532 14 05-27	Cap Asm Fuel W/sym Vented
33	532 12 34-87	Clamp Hose Black
37	532 13 70-40	Line Fuel 20"
38	532 14 83-15	Plug Drain Oil Easy
40	532 12 40-28	Bushing Shap Nyl Blk Fuel Line
41	532 13 92-77	Stem Tank Fuel
44	817 67 04-12	Screw Hexwsh Thdrol 1/4-20x3/4
45	817 00 06-12	Screw Hexwsh 3/8-16 x 3/4
46	819 09 14-16	Washer 9/32 X 7/8 X 16 Ga
62	810 04 05-00	Washer Lock Hvy Hlcl Spr 5/16
72	871 07 05-12	Screw Hexhd Cap 5/16-18x 3/4
78	817 06 06-20	Screw 3/8-16 x1-1/4
81	873 51 04-00	Nut Keps Hex 1/4-20 unc
112	532 12 49-52	Bushing

NOTE: All component dimensions given in U.S. inches
1 inch = 25.4 mm

REPAIR PARTS

TRACTOR - MODEL NO. LT16A (JLT16H42A), PRODUCT NO. 954 13 00-61
SEAT ASSEMBLY

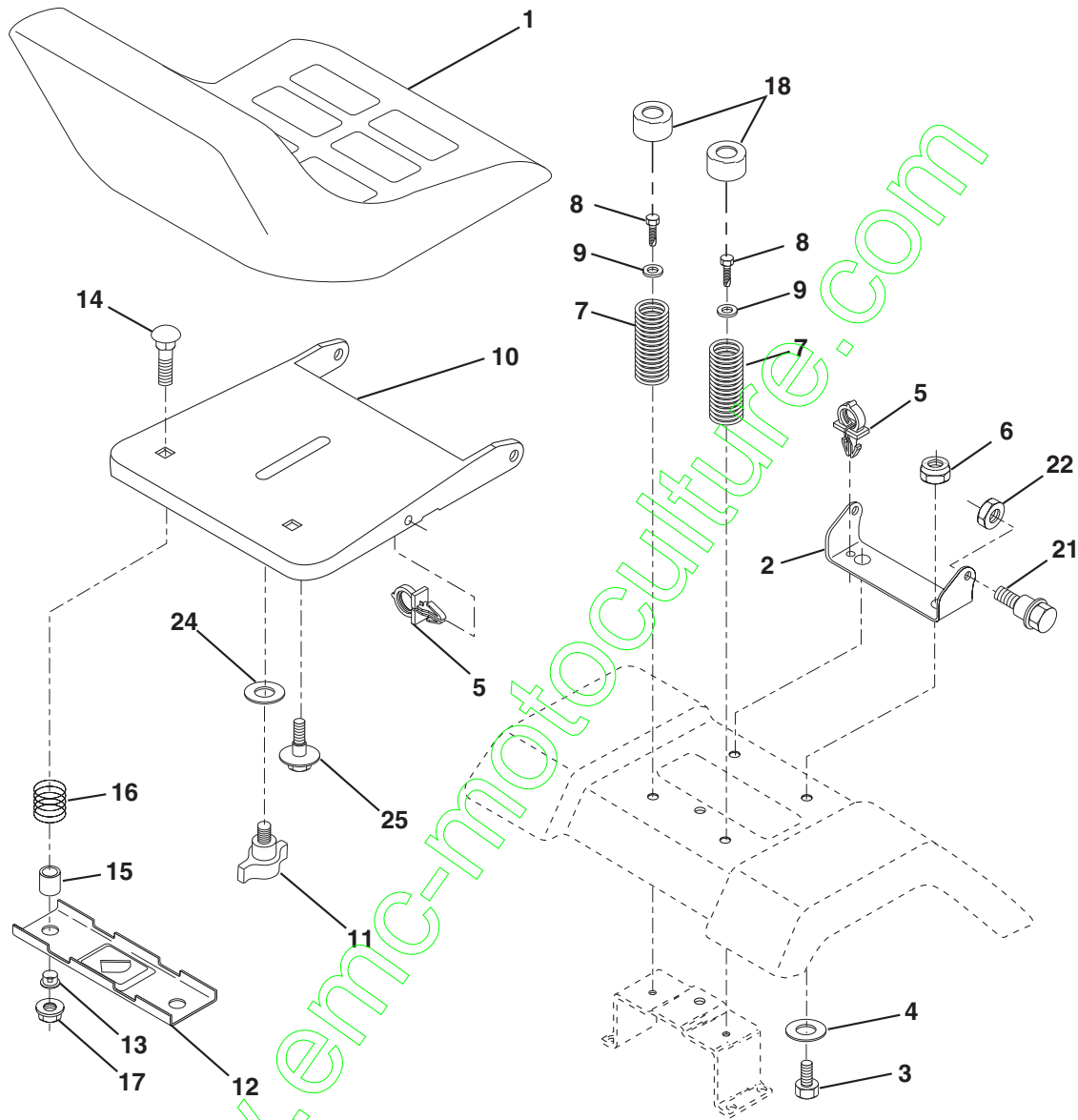

KEY NO.	PART NO.	DESCRIPTION
1	532 14 01-17	Seat
2	532 14 05-51	Bracket Pivot Seat 8 720
3	871 11 06-16	Bolt Fin Hex 3/8-16unc X 1
4	819 13 16-10	Washer 13/32 X 1 X 10 Ga
5	532 14 50-06	Clip Push-In
6	8738006-00	Nut Hex w/Ins. 3/8-16 Unc
7	532 12 41-81	Spring Seat Cprsn 2 250 Blk Zi
8	8170006-16	Screw 3/8-16 X 1-1/2
9	819 13 16-14	Washer 13/32 X 1 X 14 Ga.
10	532 18 24-93	Pan Seat
11	532 16 63-69	Knob Seat
12	532 12 12-46	Bracket Mounting Switch

KEY NO.	PART NO.	DESCRIPTION
13	532 12 12-48	Bushing Snap Blk Nyl 50 Id
14	872 05 04-12	Bolt Rdhd Sqnk 1/4-20x1-1/2
15	532 13 43-00	Spacer Split 28x96 Yel Zinc
16	532 12 12-50	Spring Cprsn 1 327 Blk Pnt
17	532 12 39-76	Nut Lock 1/4 Lge Flg Gr 5 Zinc
18	532 12 42-38	Cap Spring Seat
21	532 17 18-52	Bolt Shoulder 5/16-18 Unc
22	8738005-00	Nut Hex Lock W/Ins 5/16-18
24	819 17 19-12	Washer 17/32 X 1-3/16 X 12 Ga.
25	532 12 70-18	Bolt Shoulder 5/16-18 X 62

NOTE: All component dimensions given in U.S. inches.
1 inch = 25.4 mm

REPAIR PARTS

TRACTOR - MODEL NO. LT16A (JLT16H42A), PRODUCT NO. 954 13 00-61
DECALS

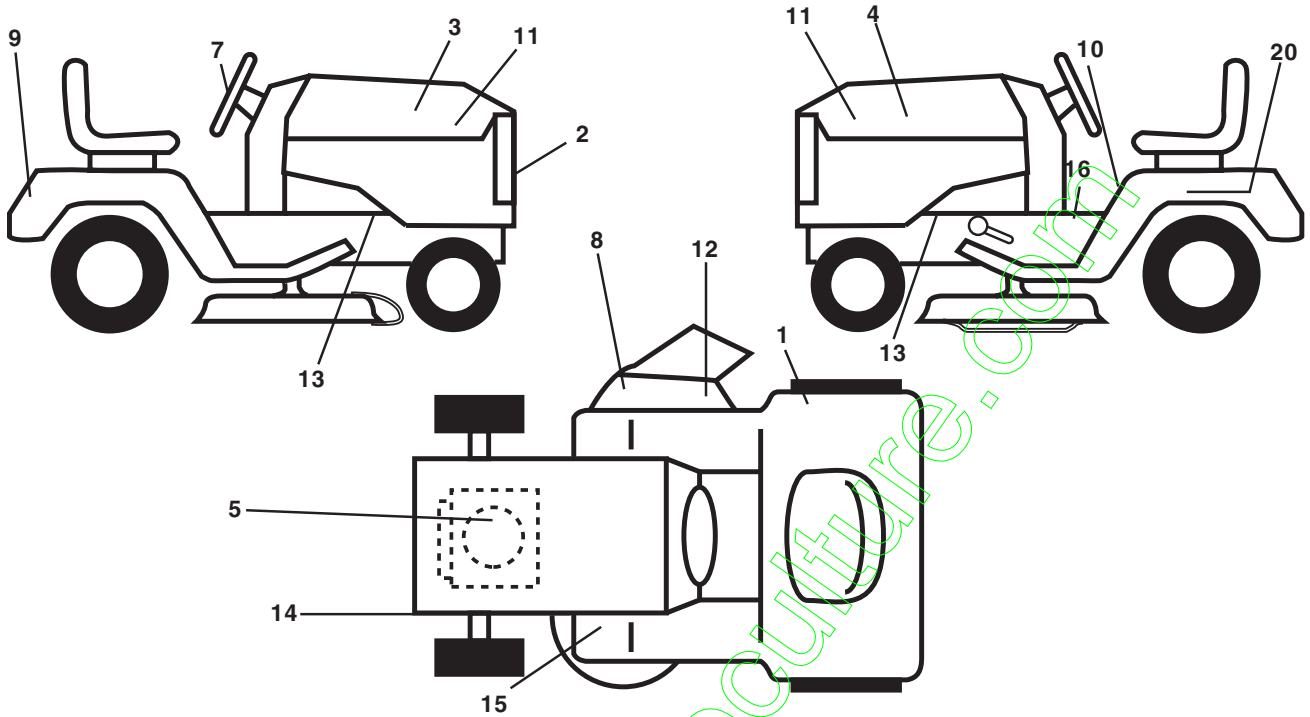

KEY NO.	PART NO.	DESCRIPTION
1	532 1804-32	Decal 100 DB/CE
2	532 1522-62	Decal Grille Jonsered Sweden
3	532 1706-00	Decal Hood RH
4	532 1706-01	Decal Hood LH
5	532 1804-34	Decal HP Engine
7	532 1705-65	Decal, Ins. Strg Whl. Jons.
8	532 1821-66	Decal Mower Cutfinger
9	532 1417-61	Decal Fender Jonsered
10	532 1454-98	Decal Read Owner's Manual Syms.
11	532 1629-27	Decal Hood Insert
12	532 1791-28	Decal Deck "B" "42"
13	532 1597-36	Decal Chassis Hot Muffler

KEY NO.	PART NO.	DESCRIPTION
14	532 1603-96	Decal V-Belt Schematic
15	532 1597-37	Decal Brake/Clutch Symbol Lt
16	532 1408-37	Decal Saddle Brake Parking
20	532 1450-05	Decal Bat Dan/Psn
--	532 1712-84	Pad Footrest LH STLT
--	532 1712-85	Pad Footrest RH STLT
--	532 1383-11	Decal Handle Lift Height Adjust
--	532 1692-10	Decal By Pass Lt Hydro
--	532 1625-98	Decal Drawbar Load Limit
--	532 1800-40	Manual Operator's (Euro.)
--	532 1800-41	Manual Operator's (Scan.)

WHEELS & TIRES

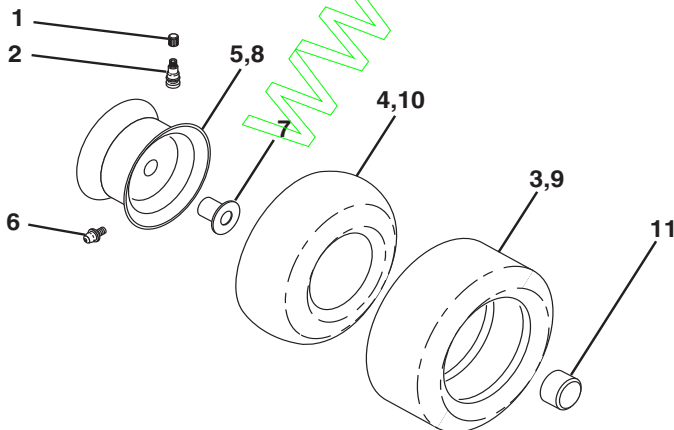

KEY NO.	PART NO.	DESCRIPTION
1	532 0591-92	Cap Valve Tire
2	532 0651-39	Stem Valve
3	532 1062-22	Tire F Ts 15 X 6 0 - 6 Service
4	532 0599-04	Tube Front (Service Item Only)
5	532 1383-36	Rim Asm 6"front Silver Service
6	532 1249-57	Fitting Grease (Front Wheel Only)
7	532 1249-59	Bearing Flange (Front Wheel Only)
8	532 1383-37	Rim Asm 8"rear Silver Service
9	532 1220-82	Tire R Ts 20x10-8 C Service
10	532 1249-26	Tube Rear (Service Item Only)
11	532 1750-39	Cap Axle Blk 1 50 X 1 00
--	532 1443-34	Sealant, Tire (10 oz. Tube)

NOTE: All component dimensions given in U.S. inches
1 inch = 25.4 mm

REPAIR PARTS

TRACTOR - MODEL NO. LT16A (JLT16H42A), PRODUCT NO. 954 13 00-61
MOWER DECK

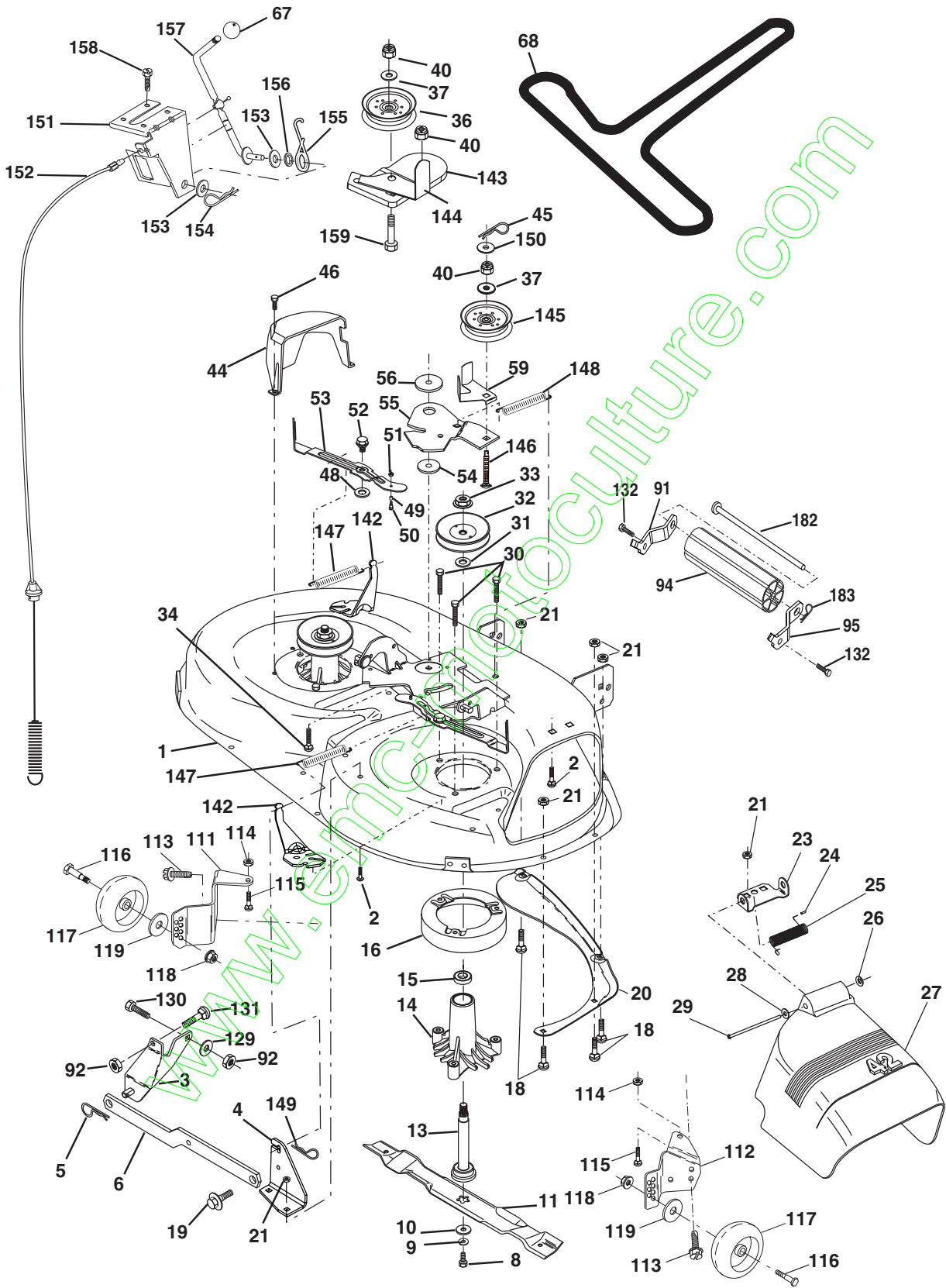

REPAIR PARTS

TRACTOR - MODEL NO. LT16A (JLT16H42A), PRODUCT NO. 954 13 00-61 MOWER DECK

KEY NO.	PART NO.	DESCRIPTION	KEY NO.	PART NO.	DESCRIPTION
1	532 1658-92	Housing Asm Mower	91	532 18 05-32	Bracket Asm Noseroller LH
2	872 14 05-06	Bolt Rdhd Sqnk 5/16-18unc X3/4	92	873 80 06-00	Nut Lock Hex w/ins. 3/8-16 UNC
3	532 13 80-17	Bracket Asm Fr Sway Bar 38/42	94	532 13 22-64	Roller Nose 38 & 42
4	532 16 54-60	Bracket Asm Deck 42"sway Bar	95	532 18 05-33	Bracket Asm Noseroller RH
5	532 12 46-70	Retainer Spring	111	532 17 92-92	Bracket Gauge Wheel Lh
6	532 17 80-24	Arm Suspension Rear	112	532 17 92-93	Bracket Gauge Wheel Rh
8	532 85 08-57	Bolt 3/8-24x1 25 Gr8 Patched	113	817 06 05-08	Screw Tapping 5/16-18 Unc
9	810 03 06-00	Washer Lock Hvy 3/8 Unplated	114	873 51 05-00	Nut Keps 5/16-18 UNC
10	532 14 02-96	Washer Hard Blade Mower Vented	115	872 11 05-05	Bolt Carriage 5/16-18unc x 1/2
11	532 13 84-98	Blade Mower High Lift"	116	532 12 48-42	Bolt Shoulder
13	532 13 76-45	Shaft Asm W/lower Bearing	117	532 16 57-46	Wheel Gauge
14	532 12 87-74	Housing Mandrel Vented(machd)	118	873 93 06-00	Nut Centerlock 3/8-16 UNC
15	532 11 04-85	Bearing Ball Mandrel	119	819 12 14-14	Washer 3/8 x 7/8 x 14 Ga.
16	532 17 44-93	Stripper Round Mower	129	819 13 13-12	Washer 13/32 x 13/16 x 12 Ga.
18	872 14 05-05	Bolt Carr 5/16-18 X 5/8	130	874 78 06-16	Bolt Fin Hex 3/8-16 UNC x 1 Gr. 5
19	532 13 28-27	Bolt Shoulder	131	872 14 06-08	Bolt Rdhd Sqnk 3/8-16 x 1
20	532 15 97-70	Baffle Vortex	132	817 06 06-12	Screw 3/8-16 x .75
21	873 68 05-00	Nut Crown Lock 5/16-18	142	532 16 58-90	Arm Spring Brake Mower
23	532 17 75-63	Bracket Deflector Mower 42"	143	532 15 71-09	Bracket Arm Idler 42"
24	532 10 53-04	Cap Sleeve 80x 112 Blk Mower	144	532 15 86-34	Keeper Belt 42" Clutch Cable
25	532 12 37-13	Spring Torsion Deflector 2 52	145	532 16 58-88	Pulley Idler Flat
26	532 11 04-52	Nut Push Phos & Oil	146	532 17 19-77	Bolt Carriage Idler
27	532 17 18-59	Shield Deflector	147	532 17 97-48	Spring Extension
28	819 11 10-16	Washer 11/32 X 5/8 X 16 Ga	148	532 16 90-22	Spring Return Idler
29	532 13 14-91	Rod Hinge 42"6 75 Wlg	149	532 16 58-98	Retainer Spring Yellow
30	532 17 39-84	Screw Thdrol Washer Head	150	819 09 12-16	Washer 9/32 x 3/4 x 16 Ga.
31	532 12 99-63	Washer Spacer Mower Vented	151	532 16 96-70	Bracket Clutch Cable
32	532 15 35-35	Pulley Mandrel	152	532 18 15-55	Clutch Cable 42"
33	532 17 83-42	Nut 9/16top Lock Flng Cntr	153	532 16 96-74	Washer Flat 3/8" Type B
34	872 11 06-14	Bolt RDHD 3/8-16 UNC x 2-3/4 Gr.5	154	532 16 96-75	Spring Retainer
36	532 13 14-94	Pulley Idler Flat 3 060	155	532 16 96-71	Spring Retention Lvr Cltch Cab
37	819 13 13-16	Washer 13/32 X 13/16 X 16 Ga	156	532 16 96-72	Spacer Clutch Cable
40	873 68 06-00	Nut Lock 3/8-16 Unc	157	532 16 96-69	Rod Clutch Cable 3/8"
44	532 14 00-88	Guard Mandrel LH Black	158	817 72 04-08	Screw Hex Thd Cut 1/4-20 x 5/8
45	532 12 47-88	Spring Retainer 1" Zinc/cad	159	872 14 06-14	Bolt Rdhd Sqn 3/8-16 Unc x 1-3/4
46	532 13 77-29	Screw Thdrol 1/4-20x5/8	160	817 06 06-12	Screw 3/8-16 x .75
48	532 13 39-44	Washer Hardened Samllr	182	532 17 91-26	Rod Noseroller
49	532 17 42-84	Roller Asm Cam Follower 42" dec	183	532 16 35-52	Retainer Spring
50	532 13 13-40	Bolt Shldr 10-24 Zinc Gr 5 42"	--	532 18 13-85	Replacement Mower, Complete
51	532 06 91-80	Nut Lock #10-24 Unc	--	532 13 07-94	Mandrel Assembly (Includes Housing, Shaft and Shaft Hardware Only-Pulley Not Included)
52	532 13 98-88	Bolt Shoulder 5/16-18 Unc Blkz			
53	532 13 18-45	Arm Asm Pad Brake			
54	532 13 39-43	Washer Hardened			
55	532 15 50-46	Arm Idler 42"mower LT/YT			
56	532 16 57-23	Spacer Retainer Mower			
59	532 14 10-43	Guard, Belt			
67	532 10 69-32	Knob Rd 3/8-16 Plstc Thds Blk			
68	532 18 02-15	V-Belt Mower			

NOTE: All component dimensions given in U.S. inches
1 inch = 25.4 mm

REPAIR PARTS

TRACTOR - MODEL NO. LT16A (JLT16H42A), PRODUCT NO. 954 13 00-61
MOWER LIFT

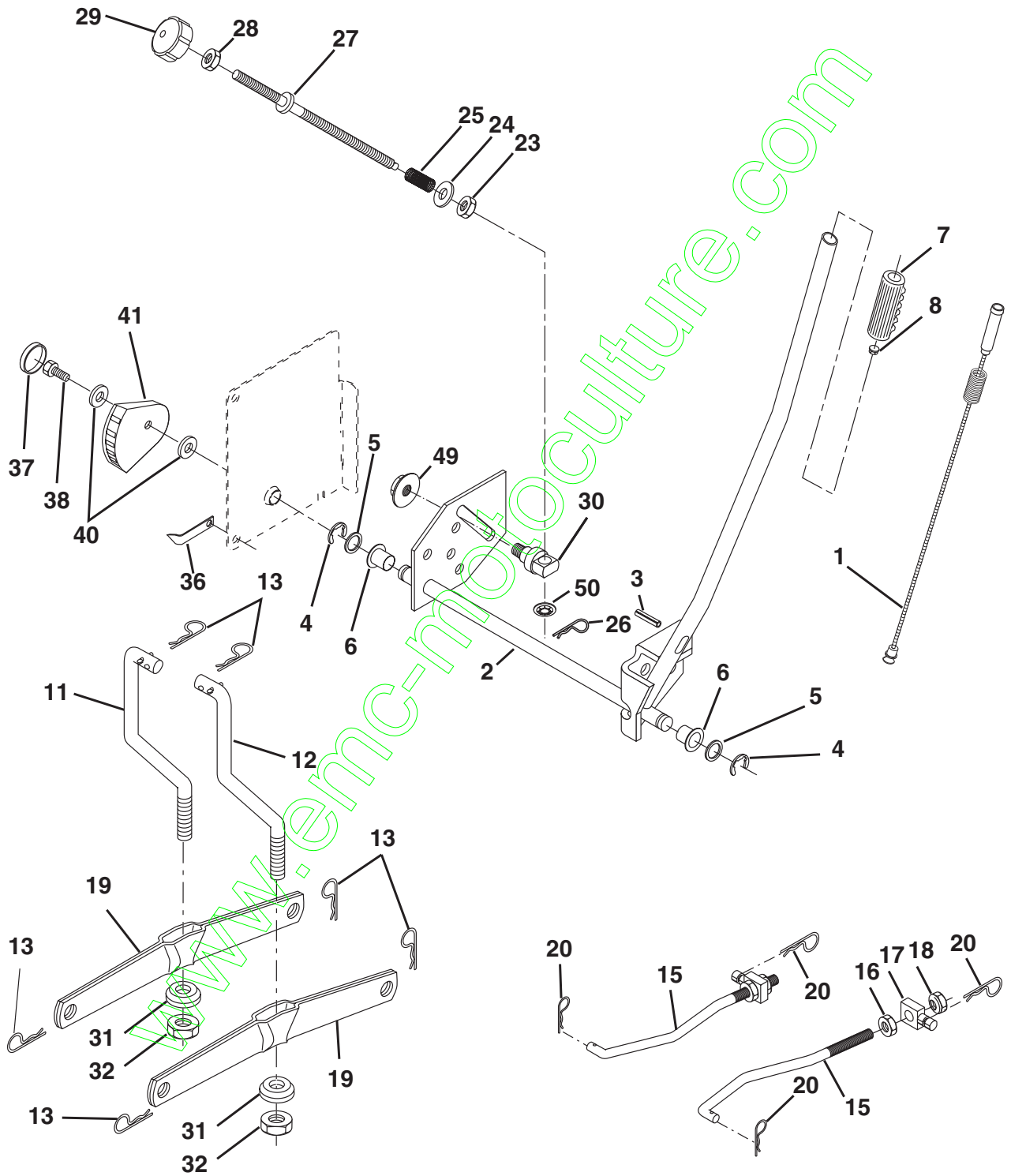

REPAIR PARTS

TRACTOR - MODEL NO. LT16A (JLT16H42A), PRODUCT NO. 954 13 00-61
MOWER LIFT

KEY NO.	PART NO.	DESCRIPTION
1	532 1594-60	Wire Asm Inner W/plunger
2	532 1594-71	Shaft Asm Lift RH
3	532 1057-67	Pin Groove 1 500 Zinc
4	8120000-02	E Ring #5133-62
5	8192116-21	Washer 21/32 X 1 X 21 Ga
6	532 1201-83	Bearing Nylon Blk 629 Id
7	532 1256-31	Grip Handle Flute Blk.
8	532 1223-65	Button Plunger
11	532 1398-65	Link Lift LH Fixed Length
12	532 1398-66	Link Lift RH Fixed Length
13	532 1246-70	Retainer Spring
15	532 1732-88	Link Front
16	873 3508-00	Nut Jam Hex 1/2-13 Unc
17	532 1756-89	Trunnion Blk Zinc
18	873 8008-00	Nut Lock w/wsh 1/2-13 Unc
19	532 1398-68	Arm Suspension Rear
20	532 1635-52	Retainer Spring
23	532 1108-07	Nut Special
24	819 1310-16	Washer 13/32 X 5/8 X 16 Ga
25	532 1248-74	Spring 2-1/8"
26	532 1694-84	Retainer Clip
27	532 1269-71	Rod Adj Lift Zinc 7.49 Wrk Lg
28	873 3506-00	Nut Hex Jam 3/8-16 Unc
29	532 1380-57	Knob Inf 3/8-16 Unc Blk W/sym
30	532 1502-33	Trunnion Dp Stop Dbl Thds PLT
31	532 1698-65	Bearing Pvt Lift
32	873 5406-00	Nut Crownlock 3/8-24
36	532 1550-97	Pointer Pnt Height ind .505
37	532 1239-35	Plug Hole Blk 1.485/1.515 Dia.
38	817 0605-16	Screw 5/16-18 x 1
40	819 1124-10	Washer 11/32 x 1-1/2 10 Ga.
41	532 1550-98	Scale Ind. Height Blk.
49	532 1452-12	Nut Hex Flange Lock
50	532 1104-52	Nut Push Phos & Oil

NOTE: All component dimensions given in U.S. inches
1 inch = 25.4 mm