

LT2115 CMA

Spare parts
Ersatzteile
Pièces détachées
Reserve onderdelen
Repuestos
Reservdelar

www.emc-motoculture.com

TRACTOR- -MODEL NO. LT2115CMA (J2115CAA), PRODUCT NO. 954 13 02-16 SCHEMATIC

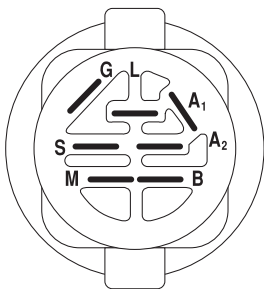
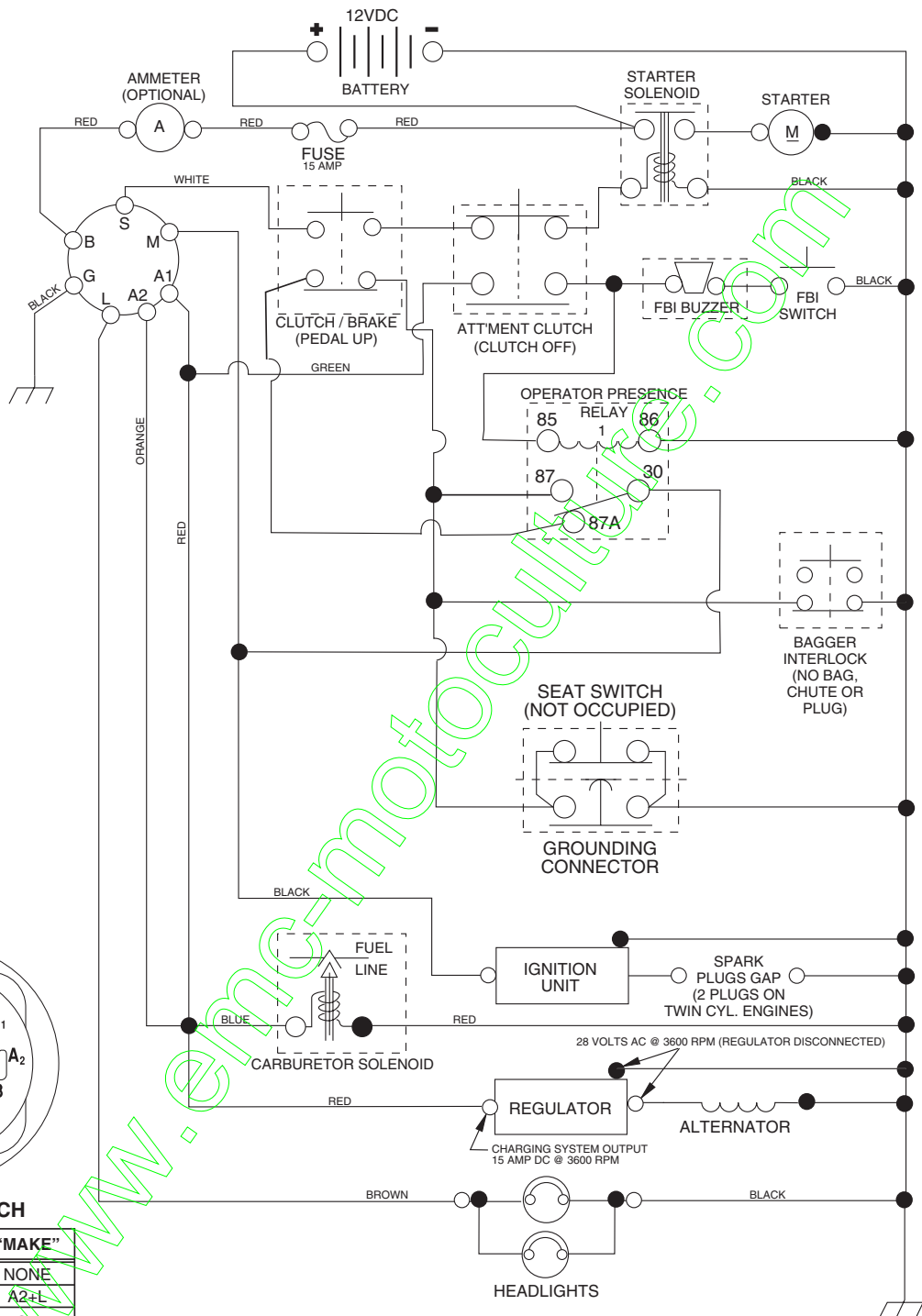

IGNITION SWITCH

POSITION	CIRCUIT	"MAKE"
OFF	M+G+A1	NONE
RUN/LIGHT	B+A1	A2+L
RUN	B+A1	NONE
START	B + S + A1	NONE

WIRING INSULATED CLIPS
NOTE: IF WIRING INSULATED CLIPS WERE REMOVED FOR SERVICING OF UNIT, THEY SHOULD BE REPLACED TO PROPERLY SECURE YOUR WIRING.

PTO SWITCH

POSITION	CIRCUIT
OFF	C + G, B + H
ON	C + F, B + E, A + D

REMOVABLE CONNECTIONS

NON-REMOVABLE CONNECTIONS

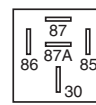

RELAY

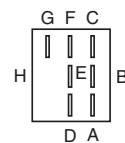

REPAIR PARTS

TRACTOR- -MODEL NO. LT2115CMA (J2115CMAA), PRODUCT NO. 954 13 02-16
ELECTRICAL

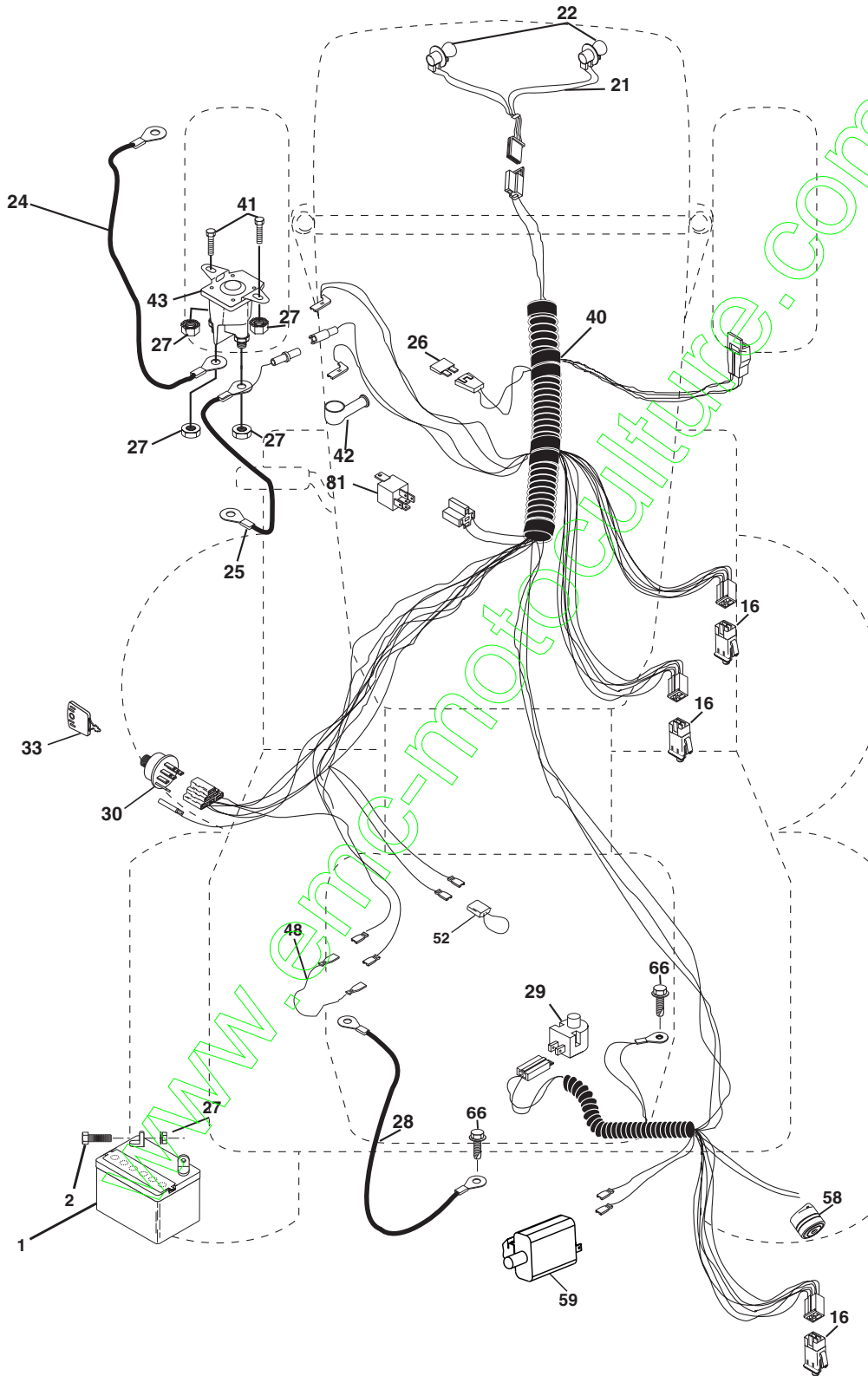

REPAIR PARTS

TRACTOR- -MODEL NO. LT2115CMA (J2115CMAA), PRODUCT NO. 954 13 02-16
ELECTRICAL

KEY NO.	PART NO.	DESCRIPTION
1	532 14 49-27	Battery
2	874 76 04-12	Bolt Hex Hd 1/4-20 unc x 3/4
16	532 17 61-38	Switch Interlock
21	532 17 56-88	Harness Asm Light W/4152J
22	532 00 41-52	Bulb Light #1156
24	532 12 47-80	Cable Starter 6 Ga. 11" Red
25	532 16 59-87	Cable Battery Crd 56" Red
26	532 17 51-58	Fuse
27	873 51 04-00	Nut Keps Hex 1/4-20 unc
28	532 12 77-25	Cable Ground 6 Ga. 18" Black
29	532 12 13-05	Switch Plunger Normal Op Gray
30	532 17 55-66	Switch Ignition
33	532 14 04-01	Key Ign
40	532 18 80-36	Harness Ign
41	871 11 04-08	Bolt Flk Fin Hex 1/4-20 unc x 1/2
42	532 13 15-63	Cover Terminal Red
43	532 17 88-61	Solenoid
48	532 14 08-44	Adapter Ammeter Rectangular
52	532 14 19-40	Protection Wire Loop
58	532 16 94-19	Buzzer Crd
59	532 18 03-79	Switch FBI CRD
66	817 49 06-08	Screw Thdrol 3/8-16 x 1/2 Ty-Tt
81	532 10 97-48	Relay Asm

NOTE: All component dimensions given in U.S. inches.
1 inch = 25.4 mm

REPAIR PARTS

TRACTOR- -MODEL NO. LT2115CMA (J2115CMAA), PRODUCT NO. 954 13 02-16
CHASSIS AND ENCLOSURES

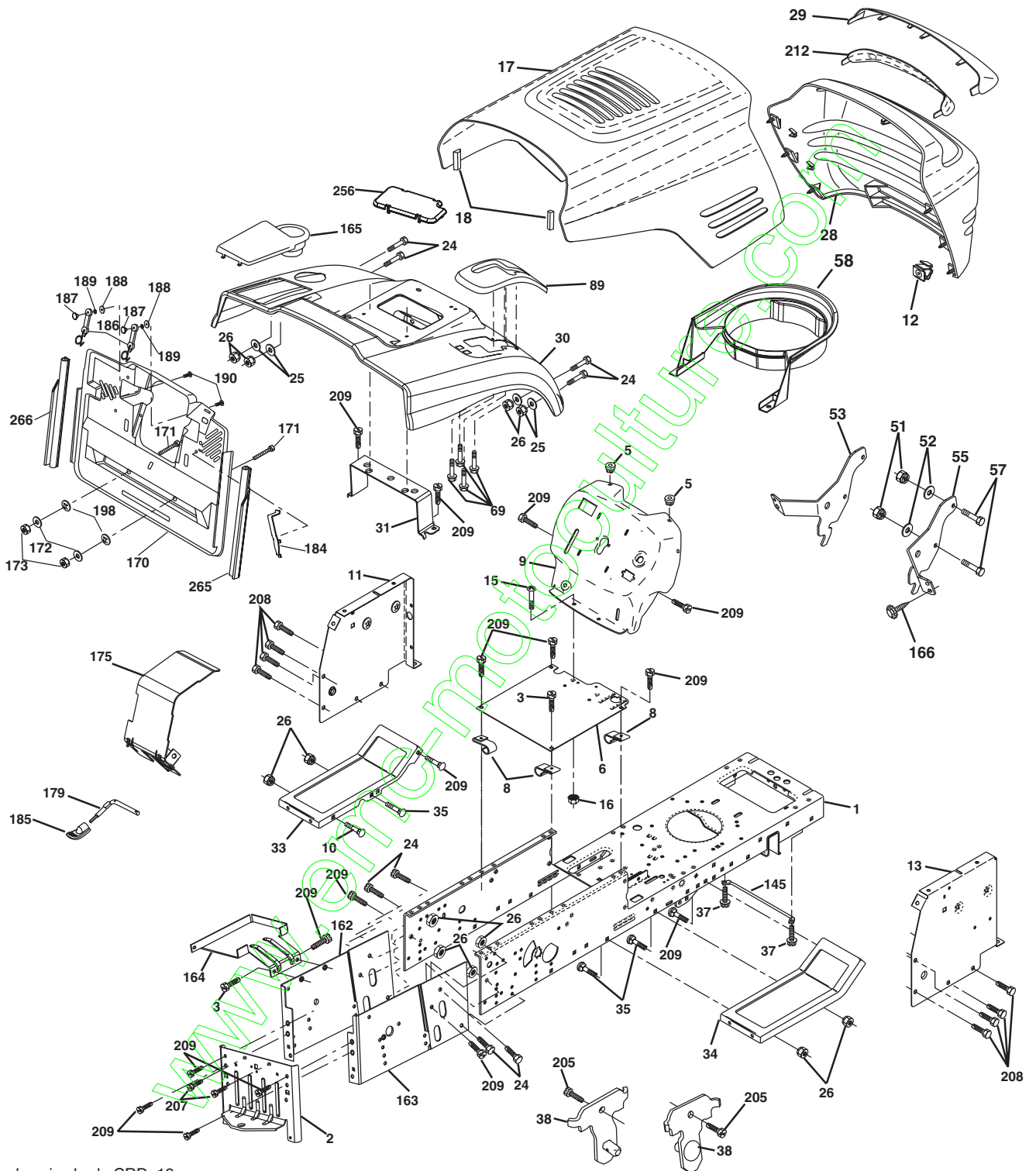

chassis-shark_CRD_13

REPAIR PARTS

TRACTOR- -MODEL NO. LT2115CMA (J2115CMAA), PRODUCT NO. 954 13 02-16 CHASSIS AND ENCLOSURES

KEY NO.	PART NO.	DESCRIPTION	KEY NO.	PART NO.	DESCRIPTION
1	532 17 46-20	Chassis	69	532 14 24-32	Screw Hex 1/4-1/2 unc
2	532 18 03-84	Drawbar	89	532 18 13-60	Console
3	817 06 06-12	Screw 3/8-16 x 3/4	145	532 15 65-24	Rod Pivot Chassis/Hood
5	532 15 52-72	Bumper Hood/Dash	162	532 18 03-82	Bracket Exten Chassis Lh CRD
6	532 18 44-19	Saddle	163	532 18 03-83	Bracket Exten Chassis Rh CRD
8	532 12 64-71	Clip Insulator 13/32 Mtg. Hole	164	532 16 56-05	Support Battery CRD
9	532 18 54-80	Dash	165	532 18 13-56	Cover Battery
10	872 14 06-08	Bolt, Carriage 3/8-16 x 3/4	170	532 17 88-62	Backplate Asm CRD
11	532 17 49-96	Panel, Dash, L.H.	171	872 14 06-20	Bolt Rdhd Sqnk 3/8-16 x 2-1/2 Gr. 5
12	532 14 56-60	Clip Tinnerman	172	819 13 20-16	Washer 13/32 x 1-1/4 x 16 Ga.
13	532 17 21-06	Panel, Asm. Dash R.H.	173	873 51 06-00	Nut, Keps Hex 3/8-16 unc
15	874 18 05-12	Screw, Machine, Truss Head 5/16-18 unc x 3/4	175	532 18 82-03	Guard Trap
16	873 51 05-00	Nut	179	532 18 82-02	Rod Pivot FBI CRD
17	532 15 07-60	Hood	184	532 17 46-62	Bracket Actuator Bagger CRD
18	532 18 49-21	Bumper Hood	185	532 18 11-01	Knob Rod Brake Parking
24	874 78 06-16	Bolt	186	532 16 07-93	Latch Asm Mulch/Bagger
25	819 13 13-12	Washer 13/32 x 13/16 x 12 Ga.	187	532 12 50-04	Nut Weld
26	873 80 06-00	Nut	188	819 06 12-16	Washer #10
28	532 17 93-51	Grille /Lens Asm	189	810 07 10-00	Washer Lock #10
29	532 17 90-14	Lens, Grille	190	871 08 10-10	Screw Pan Hd Phillip 10-24 x 5/8
30	532 18 13-59	Fender	198	532 16 89-37	Nut, Push
31	532 16 51-56	Bracket, Fender Support	205	817 49 06-08	Screw Thdrol 3/8-16 x 1/2
33	532 18 11-93	Footrest, L.H.	207	817 67 05-08	Screw 5/16-18 x 1/2
34	532 18 11-94	Footrest, R.H.	208	817 67 06-08	Screw Thdrol 3/8-16 x 1/2
35	872 11 06-06	Bolt	209	817 00 06-12	Screw Hex Wsh Thdrol 3/8-16
37	817 49 05-08	Screw Thdrol 5/16-18 x 1/2 TYT	212	532 16 59-19	Insert Lens Reflective
38	532 18 17-48	Bracket Asm Pivot Mower Rear	256	532 18 13-61	Cover Fender
51	873 80 04-00	Nut Lock w/Insert 1/4-20	265	532 18 57-04	Seal RH Side Bagger
52	819 09 14-16	Washer 9/32 x 7/8 x 16 Ga.	266	532 18 57-03	Seal LH Side Bagger
53	532 14 52-01	Bracket Grille LH	--	532 00 54-79	Plug
54	532 17 18-75	Screw Hwhd Hi-Lo #13-16 x 5/8			
55	532 14 52-02	Bracket grille RH			
57	874 78 04-12	Bolt Fin Hex 1/4-20 unc x .75			
58	532 18 46-43	Duct Air			

NOTE: All component dimensions given in U.S. inches.
1 inch = 25.4 mm.

REPAIR PARTS

TRACTOR- -MODEL NO. LT2115CMA (J2115CMAA), PRODUCT NO. 954 13 02-16 DRIVE

KEY NO.	PART NO.	DESCRIPTION	KEY NO.	PART NO.	DESCRIPTION
1	-----	Transaxle Hydro Gear 321-0510 (Order parts from transaxle manufacturer)	112	819 09 12-10	Washer 9/32 x 3/4 x 10 Ga.
8	532 16 56-19	Rod, Shift Fender Adjust Lt	120	873 90 06-00	Nut Lock Flg. 3/8-16 unc
9	532 18 03-54	Clutch Asm Noram	145	874 49 05-44	Bolt Hex FGHD 5/16-18 x Gr 5
10	876 02 04-16	Pin, Cotter 1/8 x 1	150	532 16 58-50	Bushing, Bellcrank Grnd Dr
14	810 04 04-00	Washer, Lock Hvy Helical	151	819 13 32-10	Washer 13/32 x 2 x 10 Ga.
16	873 80 05-00	Nut Lock Hex W/Ins 5/16-18 unc	156	532 16 60-02	Washer Srted 5/16 ID x 1.125
19	873 80 06-00	Nut Lock Hex w/Ins 3/8-16 unc	158	532 16 55-89	Bracket Shift Mount
21	532 12 12-74	Knob Duckhead 1/4-13 unc Blk	159	532 18 39-00	Hub Shift
22	532 17 56-07	Rod, Brake	160	819 29 20-16	Washer 29/32 x 1-1/4 x 16 Ga.
24	873 35 06-00	Nut	161	872 14 04-06	Bolt Rdhd Sqnk 1/4-20 x 3/4 Gr 5
25	532 10 68-88	Spring, Rod, Brake	162	873 68 04-00	Nut Crownlock 1/4-20 unc
26	819 13 13-16	Washer 13/32 x 13/16 x 16 Ga.	163	874 78 04-16	Bolt Hex Fin 1/4-20 unc x 1 Gr 5
27	876 02 04-12	Pin, Cotter 1/8 x 3/4	165	532 16 56-23	Bracket Pivot Lever
28	532 17 57-65	Rod, Parking Brake	166	817 49 05-10	Screw 5/16-18 x 5/8
29	532 07 16-73	Cap, Parking Brake	167	532 16 55-88	Bracket Support Shift CRD
30	532 16 95-92	Bracket, Mfg. Transaxle	168	532 16 54-92	Bolt Shoulder 5/16-18 x .561
34	532 17 55-78	Shaft, Asm Pedal Foot CRD	169	532 16 55-80	Plate Fastening Lt
35	532 12 01-83	Bearing, Nylon	171	817 49 06-08	Screw Thdrol 3/8-16 x 1/2 Ty-Tt
36	819 21 16-16	Washer 21/32 x 1 x 16 Ga.	172	532 17 02-71	Shaft Asm Shifter Frt CRD
37	532 12 49-63	Pin, Roll 3/16 x 1"	177	532 16 59-32	Keeper Flat Idler 3.06" CRD
38	532 16 59-36	Pulley Flat Composite 3.06"	178	532 16 59-33	Keeper Belt Idler 1.88" CRD
39	874 76 06-44	Bolt Fin Hex 3/8-16 unc x 2-3/4	179	532 12 09-58	Washer Sintered
40	532 12 49-65	Spacer, Split 395 x 59 Bzp	180	532 16 56-30	Pulley, Idler, Flat 1.88"CRD
42	819 13 13-12	Washer 13/32 x 13/16 x 12 Ga.	181	532 18 02-11	Bracket Idler Ground Drive CRD
43	819 11 10-12	Washer 11/32 x 5/8 x 12 Ga.	182	532 18 26-82	Keeper Belt 2.5" Od V-Idler CRD
47	532 12 77-83	Pulley, Idler, V Groove Plasic	183	532 18 60-07	Pulley V-Idler 2.50" Od CRD
48	532 15 44-07	Bellcrank Clutch Grnd Drv	184	817 49 06-44	Screw Hexwsh Thdrol 3/8-16 x 2-3/4
49	532 12 32-05	Retainer, Belt Style Spring	185	532 17 00-08	Link Shift
50	872 11 06-12	Bolt Carr. Sh. 3/8-16 x 1-1/2 Gr. 5	186	532 16 56-14	Hub Tapered Round CRD
51	873 68 06-00	Nut, Crownlock 3/8-16 unc	187	817 58 05-20	Screw Thdrol 5/16-18 x 1.25
52	873 68 05-00	Nut Crownlock 5/16-18	197	532 16 96-13	Nyliner Snap-In 5/8
53	532 10 57-10	Link, Clutch 7.66	199	532 16 96-12	Bolt Shoulder 5/16-18 unc
55	532 10 57-09	Spring, Return, Clutch	200	872 14 05-08	Bolt RDHD SQNK 5/16-18 x 1
56	817 06 06-20	Screw 3/8-16 x 1-1/4	203	871 17 07-80	Bolt Hex 7/16-20 x 5
57	532 17 01-40	V-Belt Kev 112" 0650 CRD	207	532 16 98-45	Washer Nylon Rear
62	532 12 48-72	Cover, Pedal	214	532 17 56-09	Shaft Asm. Brake
65	810 04 07-00	Washer	215	532 17 56-52	Rod Brake Hydro
66	532 15 47-78	Keeper, Belt Engine F-Proof	253	532 17 50-28	Bracket Cable Chassis
71	532 16 91-82	Strap, Torque, Rh	254	817 00 06-16	Screw 3/8-16 x 1
73	532 16 91-83	Strap, Torque, Lh	255	532 17 56-08	Brace Shaft Brake Mtg.
74	532 13 70-57	Spacer, Split	258	532 17 80-62	Clip Retainer
75	532 12 17-49	Washer 25/32 x 1-1/4 x 16 Ga.	259	532 18 02-12	Bracket Pulley
76	812 00 00-01	Ring, E	261	532 13 14-94	Pulley Idler
77	532 12 35-83	Key, Square	263	817 00 06-12	Screw 3/8-16 x 3/4
78	532 12 17-48	Washer 25/32 x 1-5/8 x 16 Ga.	264	532 18 19-95	Bracket Clutch Mounting
81	532 17 00-06	Asm, Shaft, Cross Rear	265	532 18 20-13	Spacer Idler Chassis
82	532 16 57-11	Spring, Torsion	266	532 18 20-61	Shield Idler Mower
83	819 17 12-16	Washer 17/32 x 3/4 x 16 Ga.	267	872 14 06-26	Bolt 3/8-16 x 3-1/4
84	532 17 00-07	Link, Transaxle	269	532 18 24-02	Guard Muffler RH
95	532 17 00-15	Control Asm Bypass Hydro			
96	532 12 47-88	Spring, Retainer 1"			

NOTE: All component dimensions given in U.S. inches
1 inch = 25.4 mm

REPAIR PARTS

TRACTOR- -MODEL NO. LT2115CMA (J2115CMAA), PRODUCT NO. 954 13 02-16
STEERING ASSEMBLY

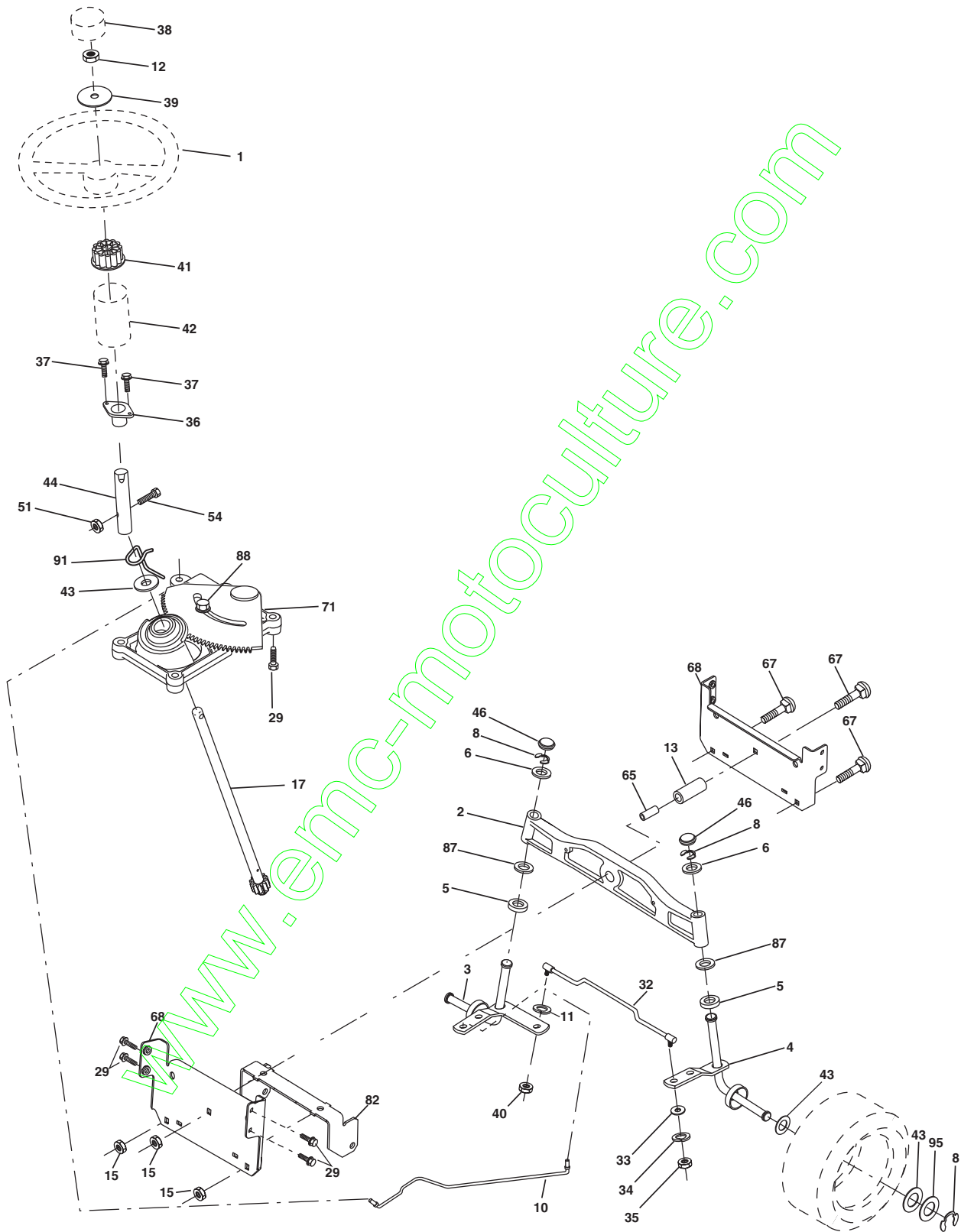

steering_pl.it_29

REPAIR PARTS

TRACTOR- -MODEL NO. LT2115CMA (J2115CMAA), PRODUCT NO. 954 13 02-16
STEERING ASSEMBLY

KEY NO.	PART NO.	DESCRIPTION
1	532 17 20-92	Steering Wheel
2	532 18 47-06	Front Axle Assembly
3	532 16 98-40	Spindle Assembly, L.H.
4	532 16 98-39	Spindle Assembly, R.H.
5	532 12 49-31	Bearing, Race, Thrust, Hardened
6	532 12 17-48	Washer 25/32 x 1-5/8 x 16 Ga.
8	812 00 00-29	Ring, Klip
10	532 17 51-21	Link, Drag
11	810 04 06-00	Washer, Lock
12	873 94 08-00	Nut Hex Jam Toplock 1/2-20 unf
13	532 13 65-18	Spacer Axle
15	532 14 52-12	Nut Hex Flange Lock
17	532 18 06-41	Shaft Assembly, Steering
29	817 00 06-12	Screw 3/8-16 x 3/4
32	532 17 01-62	Rod, Tie
33	819 11 12-16	Washer 11/32 x 3/4 x 16 Ga.
34	810 04 05-00	Washer Lock Hvy Hlcl Spr 5/16
35	873 54 05-00	Crownlock Nut 5/16-24 unf
36	532 15 50-99	Bushing, Steering
37	532 15 29-27	Screw TT #10-32 x 5 x 3/8 Flange
38	532 17 20-93	Cap Wheel Steering
39	819 18 24-11	Washer 9/16 ID x 1 1/2 OD 11 G
40	873 54 06-00	Nut Crownlock 3/8-24 unf
41	532 15 99-45	Adaptor, Steering Wheel
42	532 16 96-33	Boot, Steering
43	532 12 17-49	Washer 25/32 x 1-1/4 x 16 Ga.
44	532 18 06-40	Extension Steering
46	532 12 12-32	Cap, Spindle
51	873 54 04-00	Nut Crownlock 1/4-28
54	871 13 04-20	Bolt Hex 1/4-28 unf x 1-1/4 Gr. 8
65	532 16 03-67	Spacer Axle
67	872 11 06-18	Bolt Rdhd Sq 3/8-16 x 2-1/4
68	532 16 98-27	Brace Axle
71	532 17 51-46	Steering Asm.
82	532 16 98-35	Bracket Susp. Chassis Front
87	532 17 39-66	Washer Flat .781 x 1-1/2 x .14
88	532 17 51-18	Bolt Shoulder 7/16-20 unc
91	532 17 55-53	Clip Steering
95	532 18 89-67	Washer

NOTE: All component dimensions given in U.S. inches.
1 inch = 25.4 mm.

REPAIR PARTS

TRACTOR- -MODEL NO. LT2115CMA (J2115CMAA), PRODUCT NO. 954 13 02-16
SEAT ASSEMBLY

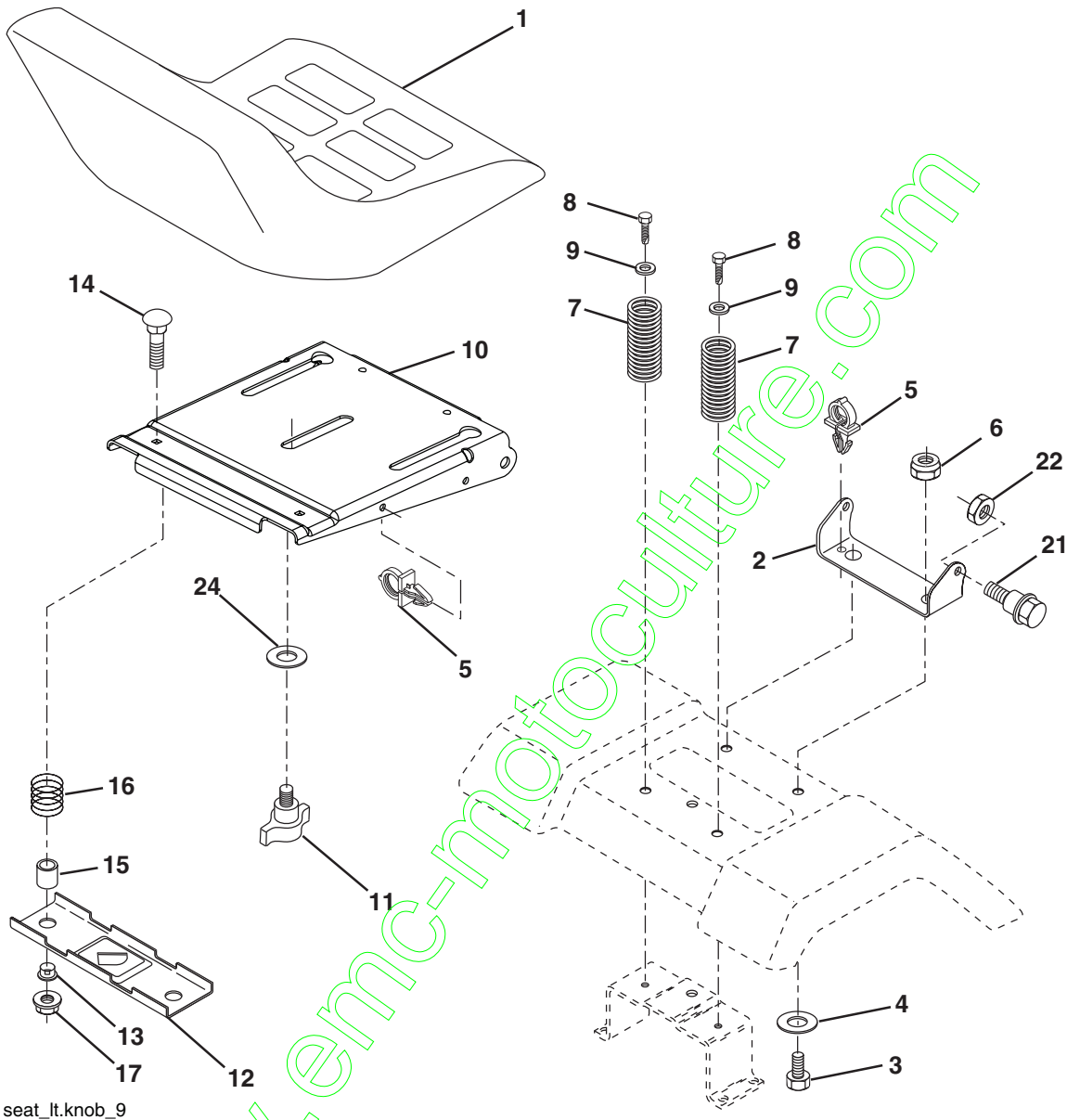

seat_lt.knob_9

KEY NO.	PART NO.	DESCRIPTION
1	532 18 87-05	Seat
2	532 18 01-66	Bracket Pnt Pivot Fender
3	871 11 06-16	Bolt Fin Hex 3/8-16 x 1
4	819 13 16-10	Washer Flat 13/32 x 1 x 10 Ga.
5	532 14 50-06	Clip Push In Hinged
6	873 80 06-00	Nut Lock Hex W/Ins 3/8-16
7	532 12 41-81	Spring Seat Cprsn 2 250 Blk Zi
8	817 00 06-16	Screw 3/8-16 x 1.5
9	819 13 16-14	Washer 13/32 x 1 x 14 Ga
10	532 18 01-86	Pan Pnt Seat
11	532 16 63-69	Knob Seat Adj. Wingnut
12	532 12 12-46	Bracket Pnt Mounting Switch

KEY NO.	PART NO.	DESCRIPTION
13	532 12 12-48	Bushing Snap Blk Nyl 50 Id
14	872 05 04-12	Bolt Rdhd Sht Nk 1/4-20 x 1-1/2
15	532 13 43-00	Spacer Split
16	532 12 12-50	Spring Cprsn
17	532 12 39-76	Nut Lock 1/4 Lge Flg Gr. 5 Zinc
21	532 17 18-52	Bolt Shoulder 5/16-18 unc-2A
22	873 80 05-00	Nut Hex Lock w/Ins 5/16-18
24	819 17 19-12	Washer 17/32 x 1-3/16 x 12 Ga.

NOTE: All component dimensions given in U.S. inches.
1 inch = 25.4 mm

REPAIR PARTS

TRACTOR- -MODEL NO. LT2115CMA (J2115CMAA), PRODUCT NO. 954 13 02-16
DECALS

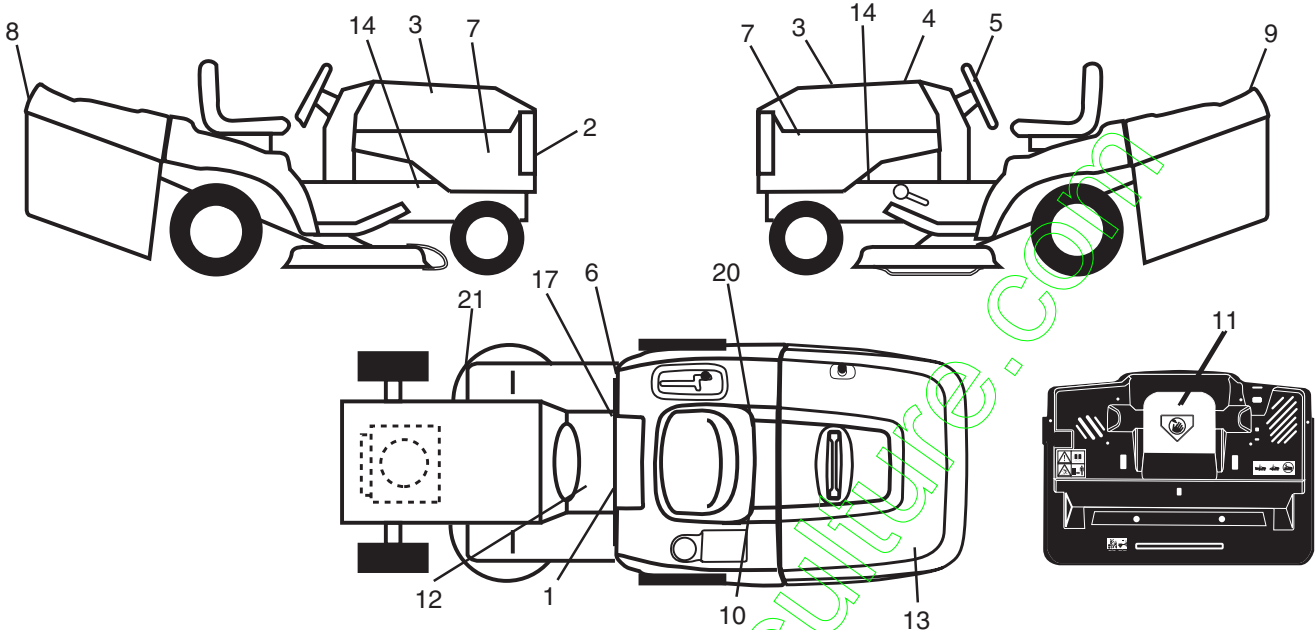

KEY NO.	PART NO.	DESCRIPTION
1	532 14 54-98	Decal Read Owner's Manual Sym
2	532 18 51-85	Decal Grille
3	532 18 95-53	Decal Hood
4	532 18 91-48	Decal Replacement
5	532 18 57-73	Decal Wheel Steering
6	532 18 04-32	Decal 100 DBA
7	532 18 88-76	Decal Hood
8	532 18 88-27	Decal Fender
9	532 18 39-30	Decal Fender Logo
10	532 14 50-05	Decal Bat Dan/Poi P/L Sym Wpn
11	532 18 21-66	Decal Mower Cut Finger Symbol

KEY NO.	PART NO.	DESCRIPTION
12	532 15 97-37	Decal Brake/Clutch Symbol Lt
13	532 18 39-31	Decal Bagger
14	532 15 97-36	Decal Chassis Hot Muffler
17	532 14 08-37	Decal Saddle Brake Parking
20	532 16 69-60	Decal Bypass Fender CRD
21	532 16 62-86	Decal Hex Belt Sch 92 CRD
—	532 13 83-11	Decal Lift Handle
—	532 18 10-90	Pad Footrest RH
—	532 18 10-91	Pad Footrest LH
—	532 18 26-21	Decal Bagger Frame
—	532 18 83-93	Manual Operator's (Euro)
—	532 18 83-94	Manual Operator's (Scan)

WHEELS & TIRES

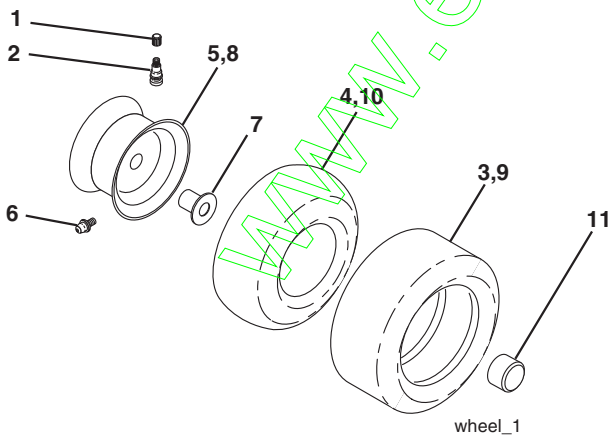

KEY NO.	PART NO.	DESCRIPTION
1	532 05 91-92	Cap Value Tire
2	532 06 51-39	Stem Value
3	532 10 62-22	Tire F Ts 15 x 6 0 - 6 Service
4	532 05 99-04	Tube Inner Front #35060
5	532 13 83-36	Rim Asm 6" front Silver Service
6	532 12 49-57	Fitting Grease
7	532 12 49-59	Bearing Flange
8	532 13 83-37	Rim Asm 8"rear Silver Service
9	532 12 20-82	Tire R Ts 20 x 10-8 Service
10	532 12 49-26	Tube Rear 9 5 x 8 Service
11	532 17 50-39	Cap Axle Blk 1 50 x 1 00
--	532 14 43-34	Sealant, Tire (10 oz. tube)

NOTE: All component dimensions given in U.S. inches
1 inch = 25.4 mm

REPAIR PARTS

TRACTOR- -MODEL NO. LT2115CMA (J2115CMAA), PRODUCT NO. 954 13 02-16
ENGINE

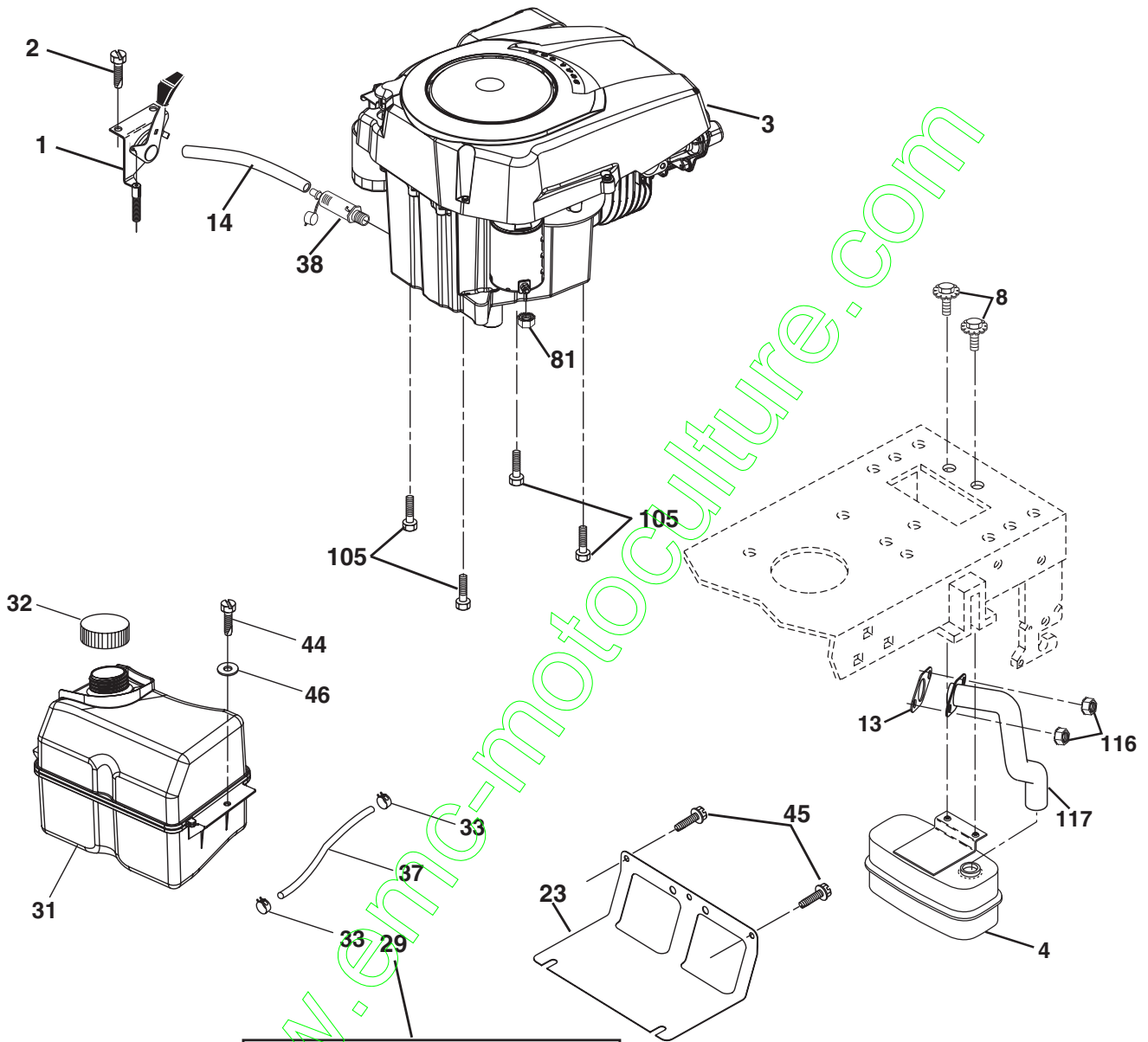

OPTIONAL EQUIPMENT
Spark Arrester

engine-kohler_42

REPAIR PARTS

TRACTOR- -MODEL NO. LT2115CMA (J2115CMAA), PRODUCT NO. 954 13 02-16
ENGINE

KEY NO.	PART NO.	DESCRIPTION
1	532 17 08-05	Control Throt/Ck
2	817 72 04-08	Screw Hex Thd Cut 1/4-20 x 1/2
3	-----	Engine Kohler Model SV470 (Order parts from engine manufacturer)
4	532 18 86-55	Muffler
8	532 17 18-77	Bolt 5/16-18 unc x 3/4 w/Sems
13	532 18 59-09	Gasket Muffler
14	532 14 84-56	Tube Drain Oil Easy
23	532 16 98-37	Shield Brn/Dbr Guard
29	532 13 71-80	Kit Spark Arrestor (Flat Scrn)
31	532 18 55-34	Tank Fuel 2.00
32	532 14 05-27	Cap Asm Fuel W/sym Vented
33	532 12 34-87	Clamp Hose Blk
37	532 13 70-40	Line Fuel
38	532 18 16-54	Plug Drain Oil Easy
44	817 67 04-12	Screw Hexwsh thdrol 1/4-20 x 3/4
45	817 00 06-12	Screw Hexwsh Thdr 3/8-16 x 3/4
46	819 09 14-16	Washer 9/32 x 7/8 x 16 Ga.
81	873 51 04-00	Nut Keps Hex 1/4-20 unc
105	817 12 06-16	Screw 3/8-16 x 1
116	532 18 43-62	Nut Hex Flange Toplock M8-1.25
117	532 18 86-54	Tube Exhaust

NOTE: All component dimensions given in U.S. inches
1 inch = 25.4 mm

REPAIR PARTS

TRACTOR- -MODEL NO. LT2115CMA (J2115CMAA), PRODUCT NO. 954 13 02-16
MOWER LIFT

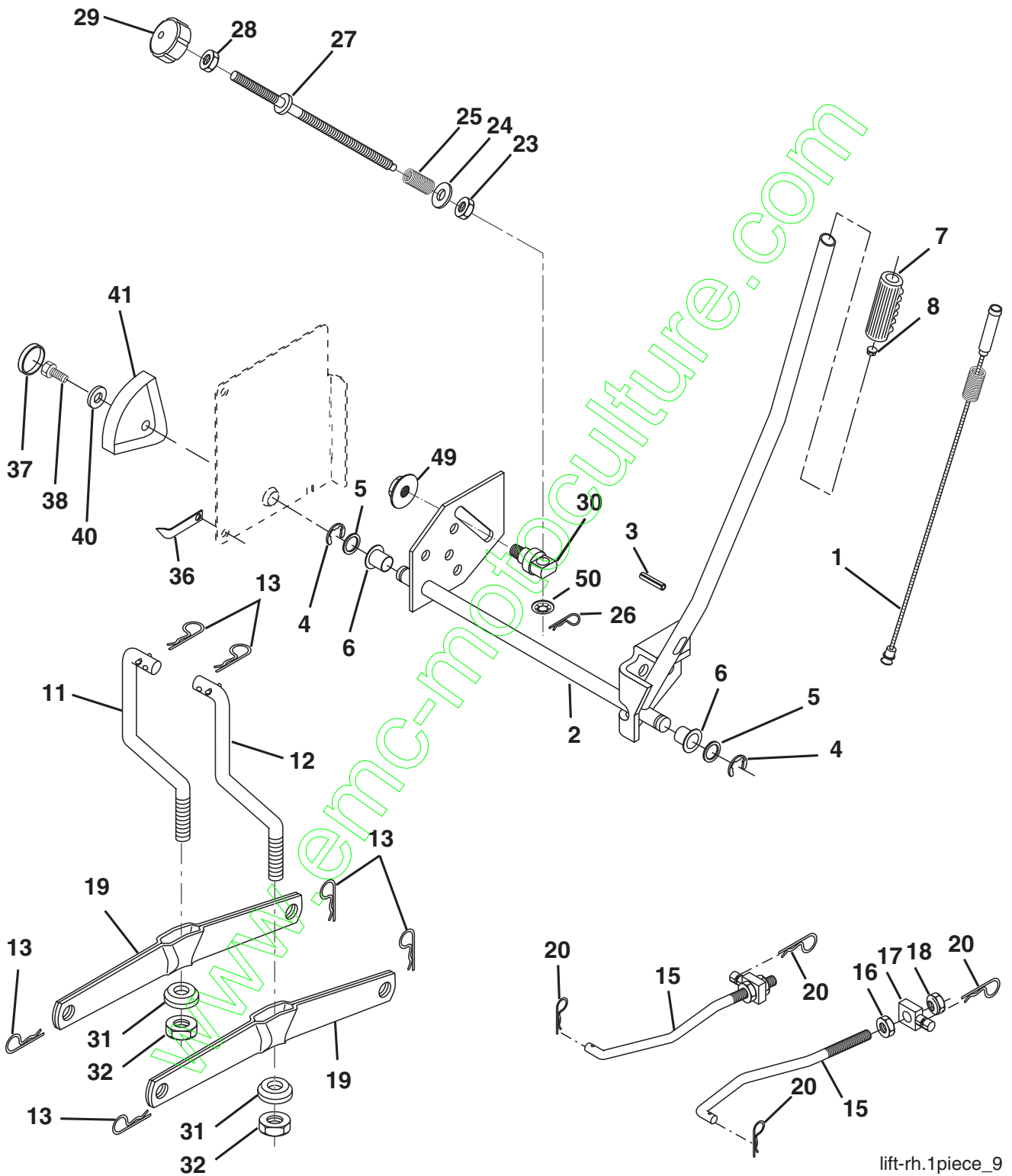

REPAIR PARTS

TRACTOR- -MODEL NO. LT2115CMA (J2115CMAA), PRODUCT NO. 954 13 02-16
MOWER LIFT

KEY NO.	PART NO.	DESCRIPTION
1	532 15 94-60	Washer Asm Inner Spring W/Plunger
2	532 15 94-71	Shaft Asm. Lift
3	532 10 57-67	Pin Groove
4	812 00 00-02	E Ring #5133-62
5	819 21 16-21	Washer 21/32 x 1 x 21 Ga.
6	532 12 01-83	Bearing Nylon
7	532 12 56-31	Grip Handle Fluted
8	532 12 45-26	Button Plunger Black
11	532 16 58-29	Link Asm Lift L.H.
12	532 16 58-31	Link Asm Lift R.H.
13	532 12 46-70	Retainer Spring
15	532 17 32-88	Link Front
16	873 35 08-00	Nut Jam Hex 1/2-13 unc
17	532 17 56-89	Trunnion Blk Zinc
18	873 80 08-00	Nut Lock w/wsh 1/2-13 unc
19	532 13 98-68	Arm Suspension Mower
20	532 16 35-52	Retainer Spring
23	532 11 08-07	Nut Special
24	819 13 10-16	Washer 13/32 x 5/8 x 16 Ga.
25	532 12 48-74	Spring 2-1/8"
26	532 16 94-84	Retainer Clip
27	532 12 69-71	Rod Adj Lift Zinc 7.49 Wrk Lg
28	873 35 06-00	Nut Hex Jam 3/8-16 Unc
29	532 13 80-57	Knob Inf 3/8-16 Unc Blk w/sym
30	532 15 02-33	Trunnion Infin Height
31	532 16 98-65	Bearing, Pvt. Lift.
32	873 54 06-00	Nut Crownlock 3/8-24
36	532 15 50-97	Pointer Height Indicator
37	532 12 39-35	Plug Hole Blk 1.485/1.515 Dia
38	817 06 05-16	Screw 5/16-18 x 1
40	819 11 24-10	Washer 11/32 x 1-1/2 x 10 Ga.
41	532 12 39-34	Scale Ind Height Blk
49	532 14 52-12	Nut hex Flange Lock
50	532 11 04-52	Nut Push Phos & Oil

NOTE: All component dimensions given in U.S. inches
1 inch = 25.4 mm

REPAIR PARTS

TRACTOR- -MODEL NO. LT2115CMA (J2115CMAA), PRODUCT NO. 954 13 02-16
MOWER

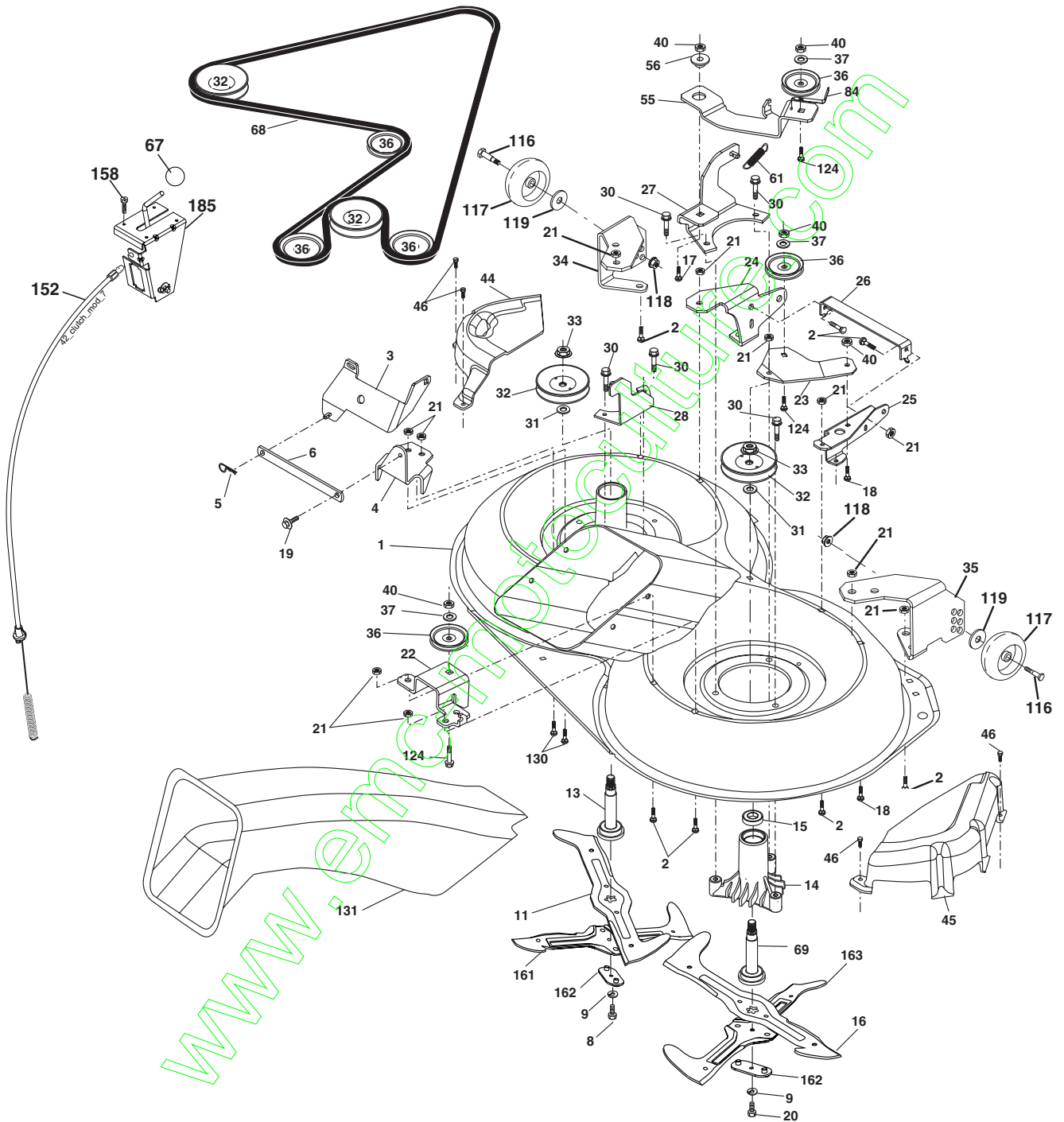

36(92cm)_deck-elect.(CRD)_1
36 GW med/wide/std

REPAIR PARTS

TRACTOR- -MODEL NO. LT2115CMA (J2115CMAA), PRODUCT NO. 954 13 02-16
MOWER

KEY NO.	PART NO.	DESCRIPTION	KEY NO.	PART NO.	DESCRIPTION
1	532 16 55-52	Housing Asm. Mower	40	873 68 06-00	Nut Crownlock 3/8-16 unc
2	872 14 05-06	Bolt Rdhd Sqnk 5/16-18 unc x 3/4	44	532 17 55-38	Cover Mandrel Lh
3	532 16 55-69	Bracket Asm. S-Bar Chass	45	532 17 55-39	Cover Mandrel Rh
4	532 16 55-58	Bracket Bar Sway Deck	46	532 13 77-29	Screw Thd Roll 1/4-20 x 5/8
5	532 12 46-70	Retainer Spring	55	532 16 54-45	Arm Idler
6	532 16 55-57	Bar Sway	56	532 16 57-23	Spacer Retainer Mower
8	532 18 17-12	Bolt 3/8-24 x 1.25 Gr. 8 Patched	61	532 16 59-45	Spring Tension Belt
9	810 03 06-00	Washer Lock Hvy 3/8 Unplated	67	532 10 69-32	Knob
11	532 18 63-85	Blade 3-1 Lh	68	532 18 02-17	Hex-Belt
13	532 13 76-45	Shaft Asm. W/Lower Bearing	69	532 16 54-82	Shaft Asm W/Lwr Brg Rh Thd CRD
14	532 12 87-74	Housing Mandrel Vented (Machd)	84	532 15 60-85	Keeper Belt Idler
15	532 11 04-85	Bearing Ball Mandrel	116	532 18 42-19	Bolt Shoulder
16	532 18 63-86	Blade 3-1 Rh	117	532 13 39-57	Wheel Gage Donut Wide
17	872 14 06-10	Bolt Carriage 3/8-16 x 1-1/4	118	873 93 06-00	Nut Centerlock 3/8-16 unc
18	872 11 06-06	Bolt Rdhd Sqnk 3/8-16 x 3/4	119	819 12 14-14	Washer 3/8 x 7/8 x 14 Ga.
19	532 13 28-27	Bolt Shoulder 5/16-18 Thd Form	124	872 11 06-12	Bolt Carr Sh 3/8-16 x 1-1/2 Gr5
20	532 18 17-13	Bolt 3/8-24 x 1.25 Gr. 8 Ptch Lhthd	130	872 11 05-06	Bolt Rdhdsqnk 5/16-18 unc x 3/4
21	873 68 05-00	Nut Crown Lock 5/16-18	131	532 16 56-61	Chute Bagger CRD 92cm
22	532 16 52-43	Bracket Idler Sprt RR	152	532 17 60-74	Cable Clutch
23	532 16 54-46	Bracket Idler Sprt RF	158	817 72 04-08	Screw Thd Cut 1/4-20 x 1/2
24	532 16 52-42	Bracket Suspension LF	161	532 18 63-87	Blade Cross LH
25	532 16 52-44	Bracket Suspension RF	162	532 18 08-78	Adapter
26	532 16 52-37	Brace Support Susp Frt	163	532 18 63-88	Blade Cross RH
27	532 16 55-68	Bracket Asm. Susp RR	185	532 18 82-34	Head Asm Cable Clutch
28	532 16 55-67	Bracket Asm. Susp LR	--	532 18 18-57	Mandrel Asm Service
30	532 17 39-84	Screw Thd Rolling	--	532 18 18-58	Mandrel Asm CRD Lh Threads SVC
31	532 18 76-90	Washer Spacer Mower Vented	--	532 18 85-23	Replacement Mower Complete (Std. Deck - Order separately gauge wheel components key nos. 116-119)
32	532 15 35-31	Mandrel Pulleys			
33	532 17 83-42	Nut Flg Top Lock			
34	532 16 52-39	Bracket Gauge Wheel Lf			
35	532 16 52-38	Bracket Gauge Wheel Rf			
36	532 14 67-63	Pulley Idler V-Groove Dim 4.25			
37	819 13 13-16	Washer 11/32 x 13/16 x 16 Ga			

NOTE: All component dimensions given in U.S. inches
1 inch = 25.4 mm

REPAIR PARTS

TRACTOR- -MODEL NO. LT2115CMA (J2115CMAA), PRODUCT NO. 954 13 02-16
BAGGER

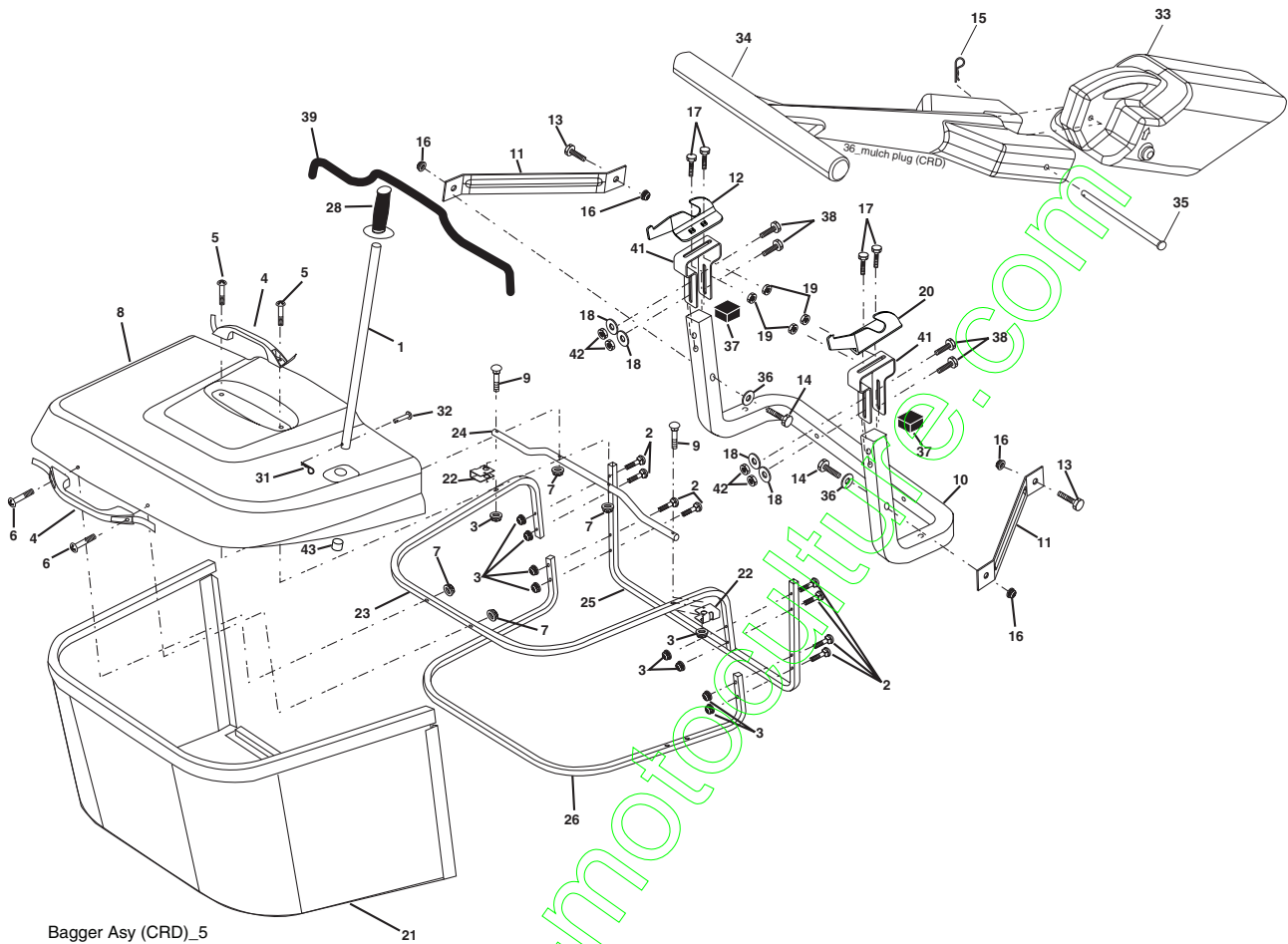

Bagger Asy (CRD)_5

KEY NO.	PART NO.	DESCRIPTION	KEY NO.	PART NO.	DESCRIPTION
1	532 16 52-49	Tube Handle Bagger CRD	20	532 16 96-84	Bracket Horiz Adj Bagger Rh
2	872 14 04-16	Bolt Carriage 1/4-20 x 2.0 Gr.5	21	532 18 08-80	Bag Asm CRD
3	532 12 39-76	Nut Lock 1/4 Lge Flg Gr. 5 Zinc	22	532 16 57-81	Bracket Side Bagger CRD
4	532 16 99-16	Handle Bagger w/Lvrs Blk CRD	23	532 16 57-82	Tube Upper Bagger CRD
5	874 98 10-24	Screw Pan Head #10-24 x 1.50 Blk	24	532 16 57-83	Tube Pivot Bagger CRD
6	874 98 10-32	Screw Pan Hd	25	532 18 01-24	Tube Front Bagger CRD
7	873 40 10-00	Nut Wiz Lock Hex Serr/Hd 10-24	26	532 16 57-85	Tube Lower Bagger CRD
8	532 18 13-54	Cover Bagger	28	532 16 57-87	Grip Handle
9	872 14 04-18	Bolt Carriage 1/4-20 x 2.25d x Gr.5	31	532 16 94-84	Retainer Clip
10	532 18 12-82	Tube Support Bagger CRD	32	532 12 68-75	Rivet Rd Hd Drilled 3/8 Dia
11	532 16 57-19	Bracket Support Upper Bag CRD	33	532 16 55-71	Plug Mulcher
12	532 16 96-85	Bracket Horiz Adj Bagger Lh	34	532 16 55-70	Handle Mulcher
13	872 11 06-06	Bolt Rdhd Sht Sqnk 3/8-16 x 3/4	35	532 16 55-72	Pin Mulcher
14	874 52 06-36	Bolt RDHD SQNK 3/8-16 x 2-1/4 Gr.5	36	819 13 20-16	Washer 13/32 x 1-1/4 x 16 Ga.
15	532 12 46-70	Retainer Spring	37	532 17 54-01	Plug Support Bagger CRD
16	873 90 06-00	Nut Lock Flg 3/8-16 unc	38	872 01 05-20	Bolt 5/16-18 x 2-1/2
17	872 14 05-06	Bolt Rdhd Sht Sqnk 5/16 -18 unc x 3/4	39	532 18 09-85	Seal
18	819 11 12-16	Washer 11/32 x 3/4 x 16 Ga.	41	532 16 96-83	Bracket Pnt Adj Pvt Bagger CRD
19	873 90 05-00	Nut Lock Hex Flange 5/16-18	42	873 80 05-00	Nut Crownlock 5/16-18 Blk D
			43	532 17 40-83	Plug Tubing End

NOTE: All component dimensions given in U.S. inches
1 inch = 25.4 mm