

# LT2117A

**Spare parts**  
**Ersatzteile**  
**Pièces détachées**  
**Reserve onderdelen**  
**Repuestos**  
**Reservdelar**

[www.emc-motoculture.com](http://www.emc-motoculture.com)

# ILLUSTRATED PARTS LIST

**MFG ID NO. 96011012600**

**CUSTOMER CATALOG NO. LT2117A**

**PRODUCT NO. 960 11 01-26**

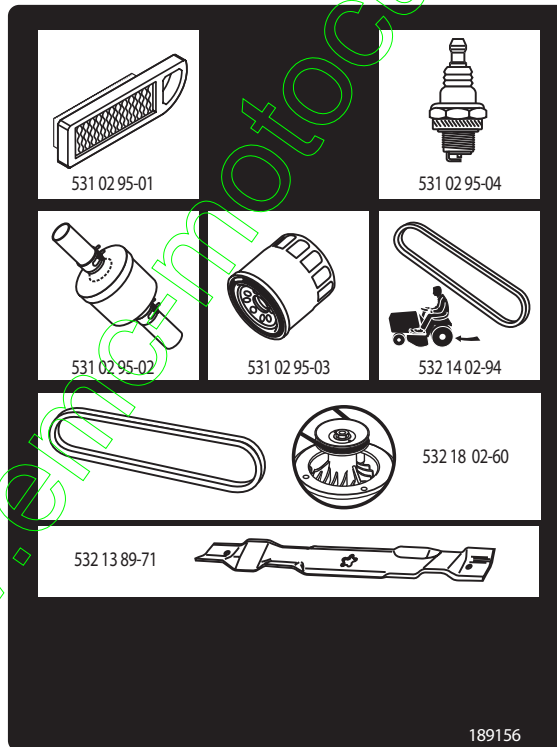

# TRACTOR - MODEL NO. LT2117A (96011012600), PRODUCT NO. 960 11 01-26 SCHEMATIC

03111\_196614

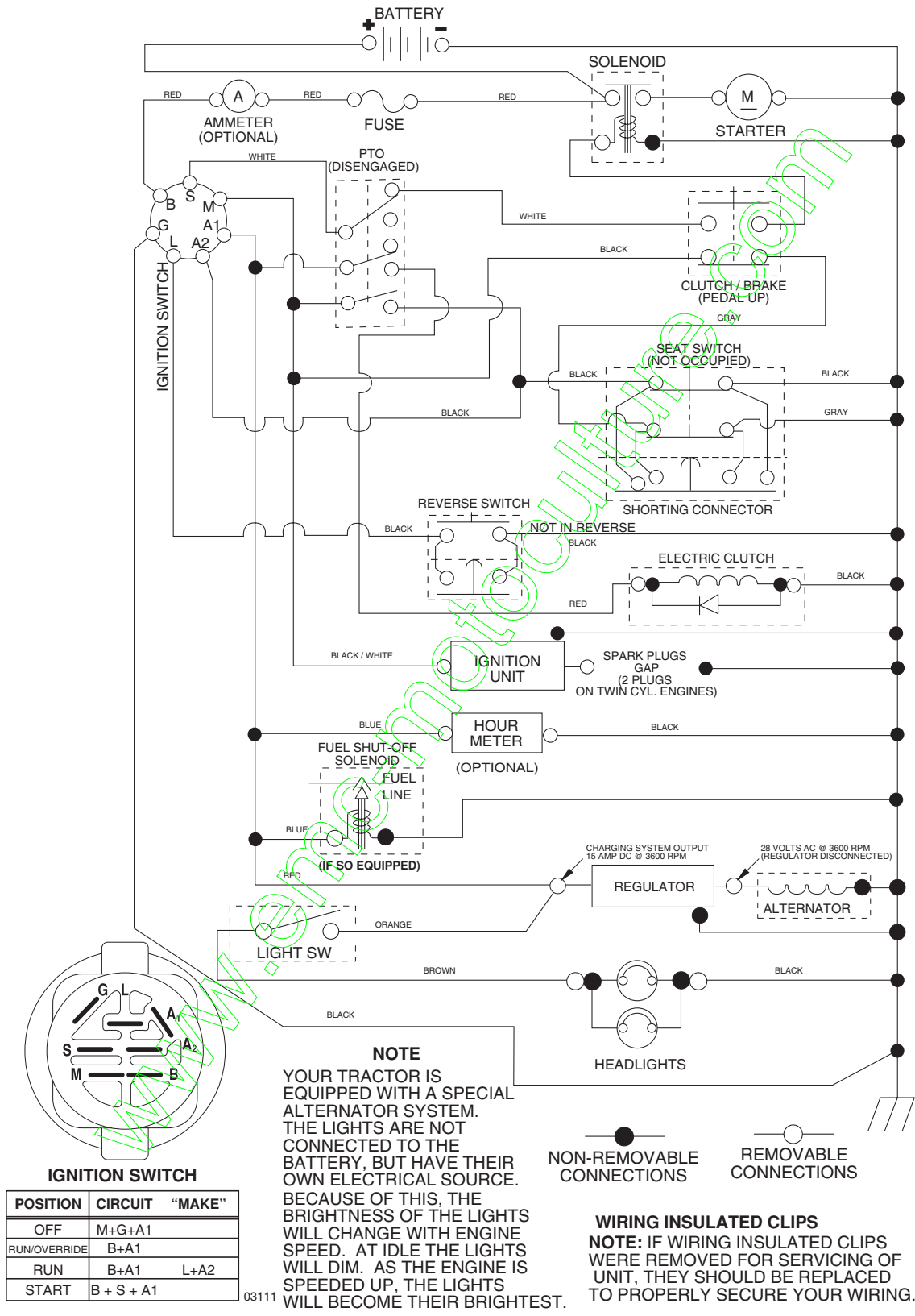

# REPAIR PARTS

TRACTOR - MODEL NO. LT2117A (96011012600), PRODUCT NO. 960 11 01-26  
ELECTRICAL

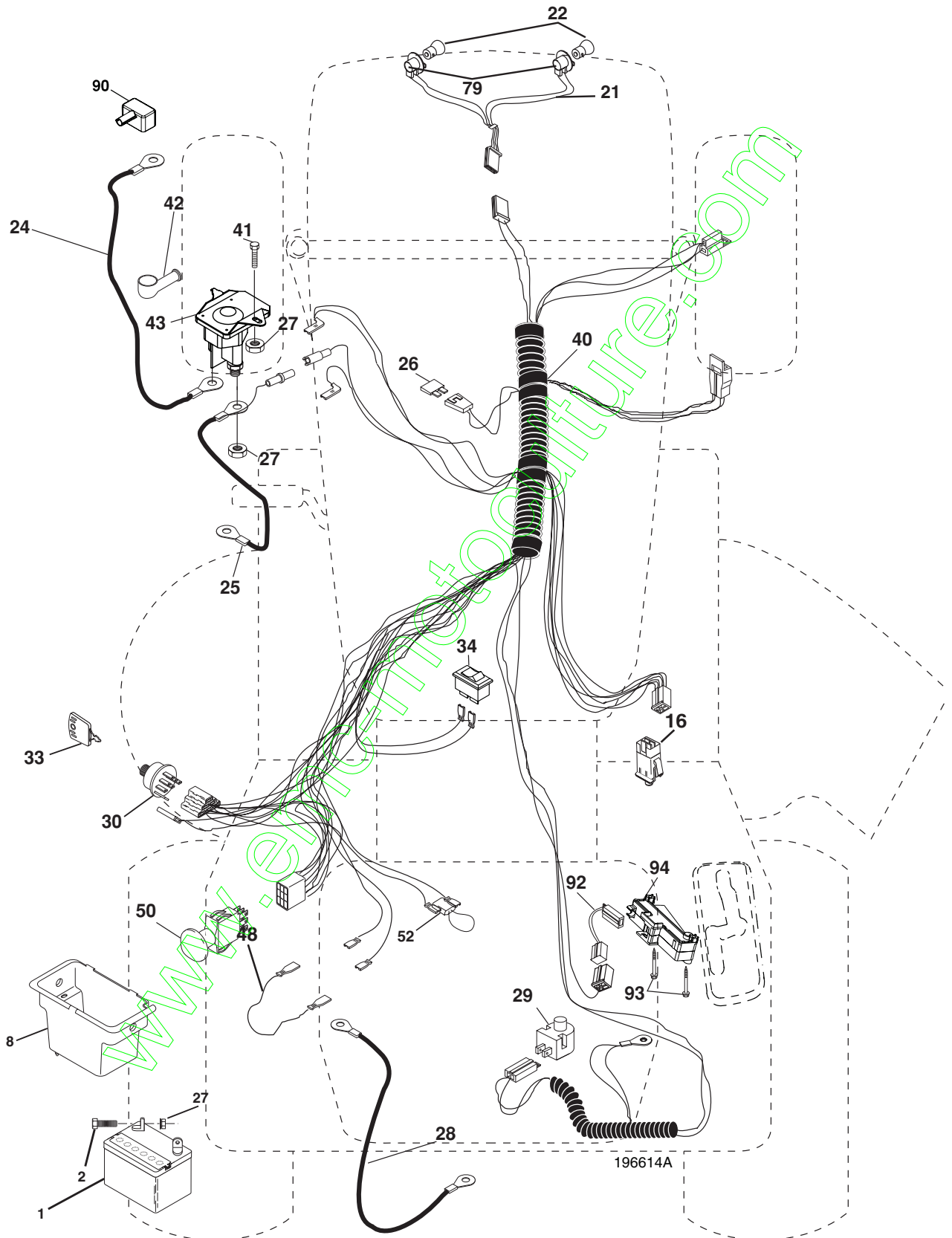

# REPAIR PARTS

TRACTOR - MODEL NO. LT2117A (96011012600), PRODUCT NO. 960 11 01-26  
ELECTRICAL

KEY NO.	PART NO.	DESCRIPTION
1	532 14 49-27	Battery
2	874 76 04-12	Bolt Hex Hd 1/4-20 unc x 3/4
8	532 17 66-89	Box Battery
16	532 17 61-38	Switch Interlock Push-In
21	532 17 56-88	Harness Asm Light W/4152J
22	532 00 41-52	Bulb Light #1156
24	532 12 47-80	Cable Battery 6 Ga. 11"red
25	532 14 61-47	Cable Battery 6 Ga. W/16 Ga. Wire 44"
26	532 17 51-58	Fuse 20 AMP
27	873 51 04-00	Nut Keps Hex 1/4-20 unc
28	532 12 47-73	Cable Ground
29	532 19 27-49	Switch Seat
30	532 19 33-50	Switch Ignition
33	532 14 04-01	Key Ign Molded Generic Delta
34	532 11 07-12	Switch Light
40	532 19 66-14	Harness Ign.
41	817 72 04-08	Screw Thd Cut 1/4-20 x 1/2
42	532 13 15-63	Cover Terminal Red
43	532 19 25-07	Solenoid
48	532 14 08-44	Adapter Ammeter
50	532 17 46-51	Switch PTO
52	532 14 19-40	Protection Wire Loop Hour Meter
79	532 17 52-42	Bulb Holder Asm
90	532 18 04-49	Cover Terminal
92	532 19 66-15	Harness Pigtail
93	532 19 25-40	Screw Plastite 10-24 x 2.0
94	532 19 18-34	Module Reverse

**NOTE:** All component dimensions given in U.S. inches  
1 inch = 25.4 mm.

# REPAIR PARTS

TRACTOR - MODEL NO. LT2117A (96011012600), PRODUCT NO. 960 11 01-26  
CHASSIS AND ENCLOSURES

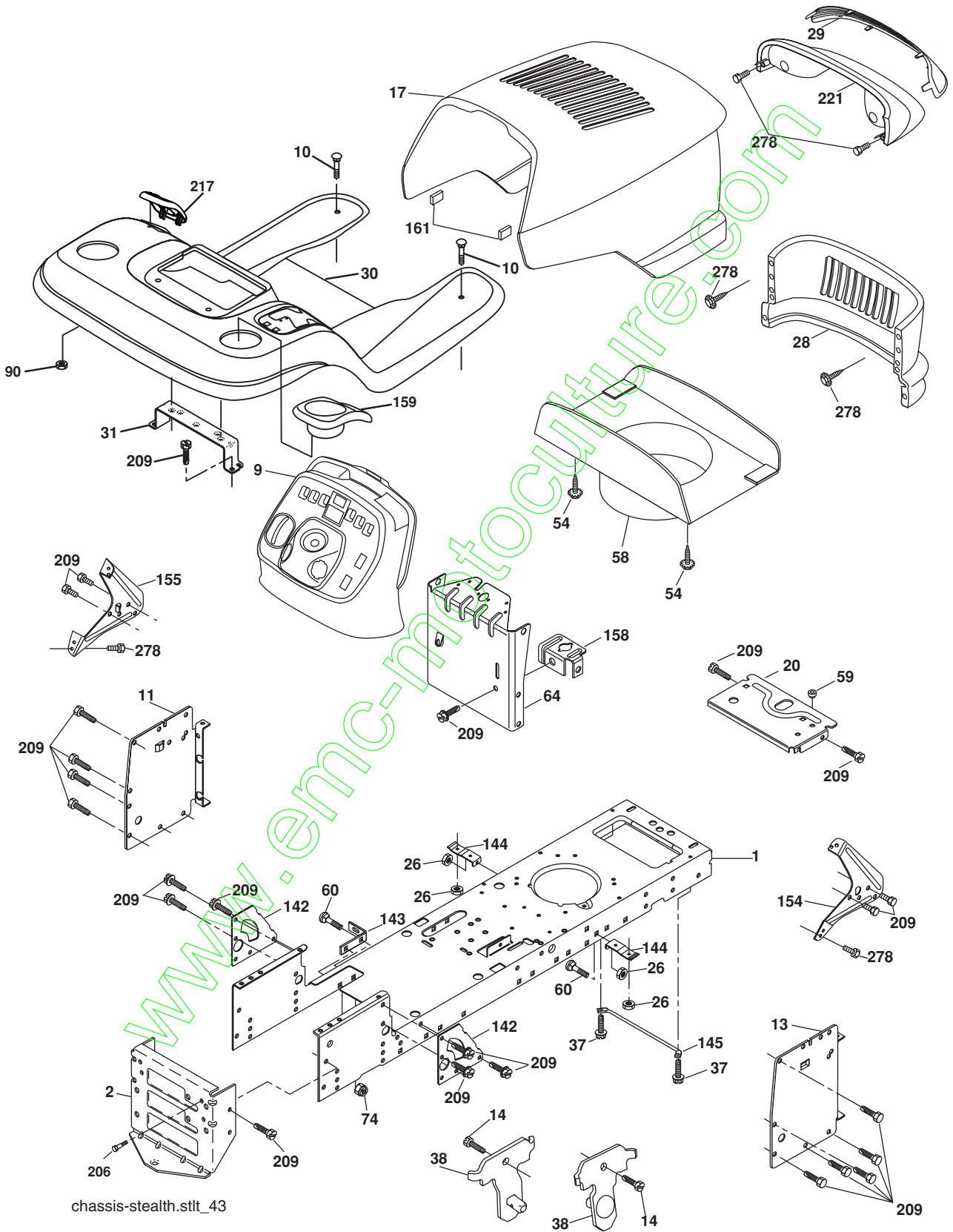

chassis-stealth.stlt\_43

# REPAIR PARTS

TRACTOR - MODEL NO. LT2117A (96011012600), PRODUCT NO. 960 11 01-26  
CHASSIS AND ENCLOSURES

KEY NO.	PART NO.	DESCRIPTION
1	532 17 46-19	Chassis Wldmt.
2	532 17 65-54	Drawbar 12 Ga
9	532 40 14-90	Dash
10	872 14 06-08	Bolt RdHd Sqnk. 3/8-16 x 1
11	532 16 72-03	Panel Asm. Dash Lh
13	532 17 82-98	Panel Dash Rh
14	817 49 06-08	Screw Thdrol 3/8-16 x 1/2
17	532 18 13-51	Hood Pnt
26	873 80 06-00	Nut Lock Hex w/Ins 3/8-16 Unc
28	532 18 13-52	Grill
29	532 17 97-61	Lens Grille
30	532 40 14-91	Fender /Ftrest Pnt STL
31	532 13 99-76	Bracket Fender
37	817 49 05-08	Screw Thdrol 5/16-18 x 1/2
38	532 17 57-10	Bracket Asm. Pvt. Mwr. Rear
54	532 19 25-12	Screw 10-32 x 5/8
58	532 17 53-51	Duct Air
60	872 14 06-06	Bolt Rdhd Sqnk 3/8-16 Unc x 3/4
64	532 17 49-97	Dash Lower
74	873 68 06-00	Nut, Crownlock 3/8-16 Unc
142	532 17 57-02	Plate Reinforcement STLT
143	532 18 66-89	Bracket Sway Bar
144	532 17 55-82	Bracket Footrest STLT
145	532 15 65-24	Rod Pivot Chassis/Hood
154	532 18 39-25	Bracket Dash STL RH
155	532 18 39-26	Bracket Dash STL LH
158	532 16 20-37	Bracket Parking Brake
159	532 18 13-55	Cupholder
161	532 16 46-55	Extrusion Bumper
206	532 17 01-65	Bolt Shoulder 5/16-18
209	817 00 06-12	Screw Hexwsh Thdr 3/8-16 x 3/4
221	532 16 18-40	Lens Bar
278	532 19 16-11	Screw 10 x 3/4 Single Lead Hex

**NOTE:** All component dimensions given in U. S. inches  
1 inch = 25.4 mm

# REPAIR PARTS

TRACTOR - MODEL NO. LT2117A (96011012600), PRODUCT NO. 960 11 01-26  
DRIVE

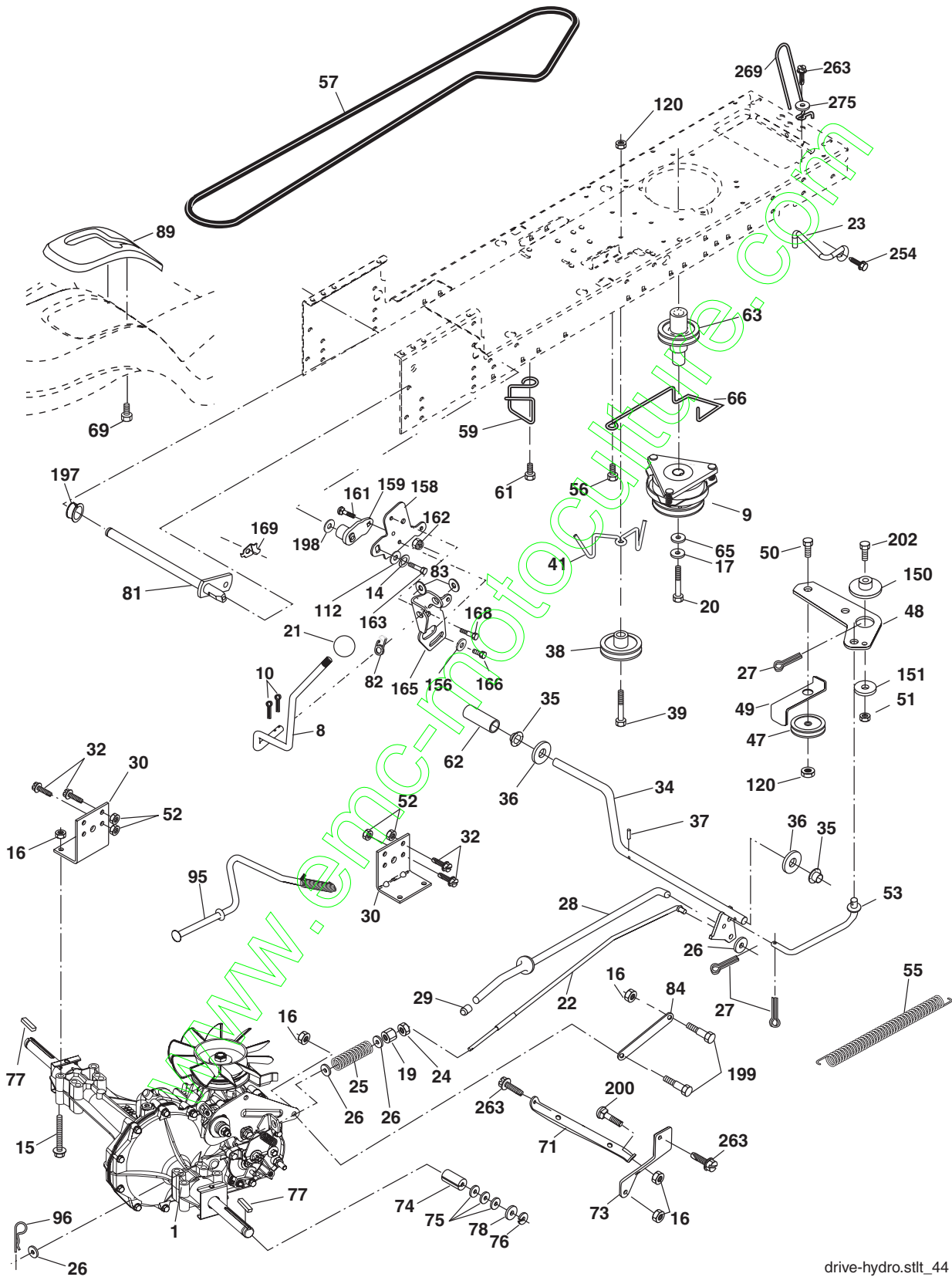



# REPAIR PARTS

**TRACTOR - MODEL NO. LT2117A (96011012600), PRODUCT NO. 960 11 01-26  
DRIVE**

KEY NO.	PART NO.	DESCRIPTION	KEY NO.	PART NO.	DESCRIPTION
1	-----	Transaxle Hydro Gear 314-0510 Order parts from transaxle manufacturer	65	810 04 07-00	Washer
8	532 19 25-02	Rod Shift Fender	66	532 15 47-78	Keeper Belt Engine Hydro
9	532 18 02-20	Clutch Electric	69	532 14 24-32	Screw Hex Wsh Hi-Lo 1/4-1/2 unc
10	876 02 04-16	Pin Cotter 1/8 x 1 CAD	71	532 16 91-83	Strap Torque Lh Hydro
14	810 04 04-00	Washer Lock Hvy Helical	73	532 16 91-82	Strap Torque Rh Hydro
15	874 49 05-44	Bolt Hex Flghd. 5/16-18 Gr.5	74	532 13 70-57	Spacer, Axle
16	873 80 05-00	Nut Lock Hex W/Ins. 5/16-18 Unc P	75	532 12 17-49	Washer 25/32 x 1-1/4 x 16 Ga.
17	532 12 61-97	Washer 1-1/2 OD x 15/32 ID x .250	76	812 00 00-01	E-Ring
19	873 80 06-00	Nut Lock Hex W/Wsh 3/8-16 Unc	77	532 12 35-83	Key, Square
20	532 17 39-37	Bolt, Hex 7/16-20 x 4 x Gr. 5-1.5	78	532 12 17-48	Washer 25/32 x 1-5/8 x 16 Ga.
21	532 13 05-64	Knob Deluxe	81	532 16 55-96	Shaft Asm Cross Tapered 510 20"
22	532 16 94-98	Rod, Brake Hydro	82	532 16 57-11	Spring Torsion T/A
23	532 19 07-36	Bracket Asm Anti Rot	83	819 17 12-16	Washer 17/32 x 3/4 x 16 Ga.
24	873 35 06-00	Locknut	84	532 16 95-94	Link Transaxle HB-0510
25	532 10 68-88	Spring, Brake Rod	89	532 19 57-46	Console, Shift
26	819 13 13-16	Washer	95	532 17 02-01	Control Asm. Bypass Hydro
27	876 02 04-12	Pin Cotter 1/8 x 3/4 CAD.	96	532 12 47-88	Retainer Spring 1" Zinc/Cad
28	532 17 57-65	Rod, Parking Brake	112	819 09 12-10	Washer 9/32 x 3/4 x 10 Ga
29	532 07 16-73	Cap, Parking Brake	120	873 90 06-00	Nut Lock Flg 3/8-16
30	532 16 95-92	Bracket, Transaxle	150	532 17 54-56	Spacer Retainer
32	874 76 05-12	Bolt Hex Hd 5/16-18 Unc x 3/4	151	819 13 32-10	Washer 13/32 x 2 x 10 Ga.
34	532 17 55-78	Shaft, Foot Pedal	156	532 16 60-02	Washer Srrtd 5/16ID x 1.125
35	532 12 01-83	Bearing, Nylon	158	532 16 55-89	Bracket Shift Mount
36	819 21 16-16	Washer	159	532 18 39-00	Hub Shift
37	532 12 49-63	Pin, Roll	161	872 14 04-06	Bolt Rdhd Sqnk 1/4-20 x 3/4 Gr 5
38	532 17 91-14	Pulley, Composite, Flat	162	873 68 04-00	Nut Crownlock 1/4-20 Unc
39	872 11 06-22	Bolt RDHD 3/8-16 Unc x Z-3/4 Gr.5	163	874 78 04-16	Bolt Hex Fin 1/4-20 Unc x 1 Gr 5
41	532 17 55-56	Keeper, Belt Idler Flat	165	532 16 56-23	Bracket Pivot Lever
47	532 12 77-83	Pulley, Idler, V-Groove	166	817 49 05-10	Screw 5/16-18 x 5/8
48	532 15 44-07	Bellcrank Grnd Clutch	168	532 16 54-92	Bolt Shoulxder 5/16-18 x .561
49	532 12 32-05	Retainer, Belt	169	532 16 55-80	Plate Fasteneing Lt
50	872 11 06-12	Bolt Carr. Sh. 3/8-16 x 1-1/2 Gr. 5	197	532 16 96-13	Nylinder Snap-In
51	873 68 06-00	Nut	198	532 16 95-93	Washer Nyl. 7/8 ID x .105"
52	873 68 05-00	Nut Crown Lock 5/16-18	199	532 16 96-12	Bolt Shoulder 5/16-18
53	532 19 96-52	Link, Clutch	200	872 14 05-08	Bolt Rdhd Sqnk 5/16-18 x 1
55	532 10 57-09	Spring, Return, Clutch	202	872 11 06-12	Bolt Carr Sh 3/8-16 x 1-1/2 Gr. 5
56	817 06 06-20	Screw 3/8-16 x 1-1/4	254	817 00 06-16	Screw 3/8-16 x 1
57	532 14 02-94	V-Belt, Ground Drive	263	817 00 06-12	Screw Hex Wsh Thdr 3/8-16 x 3/4 BL
59	532 16 96-91	Keeper, Center Span	269	532 18 24-02	Guard Muffler OHV B&S RH
61	817 12 06-14	Screw 3/8-16 x .875 SMGML Tap/R.Z	275	819 13 16-14	Washer 13/32 x 1 x 14 Ga.
62	532 12 48-72	Cover, Pedal			
63	532 17 46-07	Pulley, Engine			

**NOTE:** All component dimensions given in U.S. inches  
1 inch = 25.4 mm.

# REPAIR PARTS

TRACTOR - MODEL NO. LT2117A (96011012600), PRODUCT NO. 960 11 01-26  
STEERING ASSEMBLY

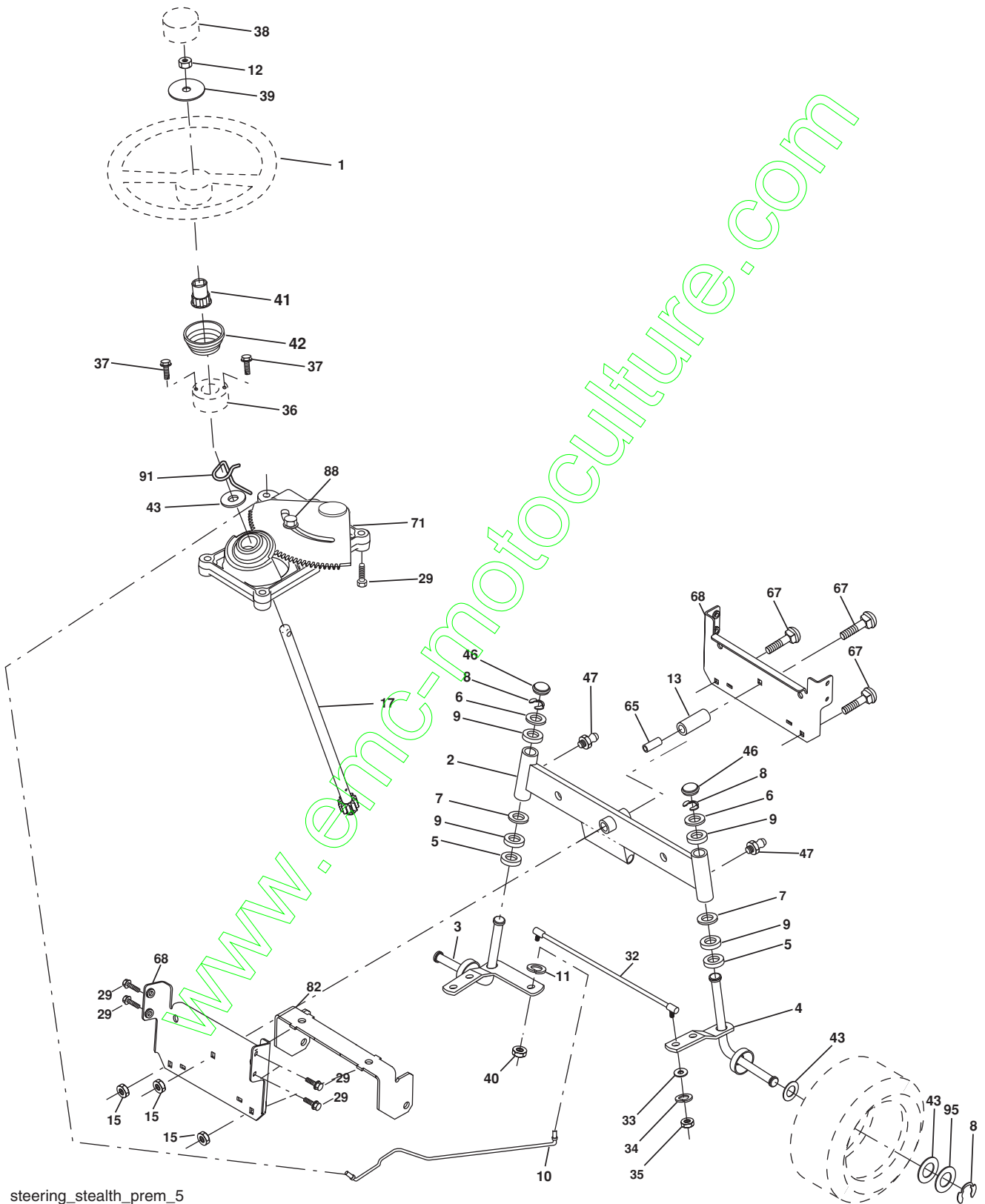

# REPAIR PARTS

TRACTOR - MODEL NO. LT2117A (96011012600), PRODUCT NO. 960 11 01-26  
STEERING ASSEMBLY

KEY NO.	PART NO.	DESCRIPTION
1	532 19 46-37	Wheel Steering
2	532 17 51-31	Axle Front
3	532 16 98-40	Spindle Asm LH
4	532 16 98-39	Spindle Asm Stmp RH
5	532 12 49-31	Bearing Race Thrust Harden
6	532 12 17-48	Washer 25/32 x 1-5/8 x 16 Ga
7	819 27 20-16	Washer 27/32 x 1-1/4 x 16 Ga.
8	812 00 00-29	Ring Klip #t5304-75
9	532 12 49-37	Bearing Col. Strg.
10	532 17 51-21	Link Drag
11	810 04 06-00	Washer Lock Hvy Hlcl Spr 3/8
12	873 94 08-00	Nut Hex Jam Top Lock 1/2-20
13	532 13 65-18	Spacer Bearing Axle Front
15	532 14 52-12	Nut Hex Flange Lock
17	532 17 78-83	Shaft Asm Strg
29	817 00 06-12	Screw 3/8-16 x .75
32	532 17 18-88	Rod Asm Tie Ball J Solid
33	819 11 12-16	Washer 11/32 x 3/4 x 16 Ga.
34	810 04 05-00	Washer Lock Hvy HLCL Spr. 5/16
35	873 54 05-00	Nut Crown Lock 5/16-24
36	532 15 51-05	Bushing Strg
37	532 15 29-27	Screw TT #32.5 x 5 x 3/8 Flange
38	532 19 46-03	Cap Wheel Steer
39	819 18 38-12	Washer 9/16 ID x 2-3/8 OD 12 Ga.
40	873 54 06-00	Nut Crownlock 3/8-24
41	532 18 67-37	Adaptor Wheel Strg
42	532 17 71-49	Boot Dash Steering
43	532 12 17-49	Washer 25/32 x 1-1/4 x 16 Ga
46	532 12 12-32	Cap Spindle Fr Top Blk
47	532 18 32-26	Fitting Grease
65	532 16 03-67	Spacer
67	872 11 06-18	Bolt Rdhd Sqnk 3/8-16 x 2-1/4
68	532 16 98-27	Brace, Axle
71	532 17 51-46	Steering Asm
82	532 19 99-78	Bracket Susp Chassis
88	532 17 51-18	Bolt Shoulder 7/16-20
91	532 17 55-53	Clip Steering
95	532 18 89-67	Washer Harden .793 x 1.637 x 060

**NOTE:** All component dimensions given in U.S. inches  
1 inch = 25.4 mm.

# REPAIR PARTS

TRACTOR - MODEL NO. LT2117A (96011012600), PRODUCT NO. 960 11 01-26  
SEAT ASSEMBLY

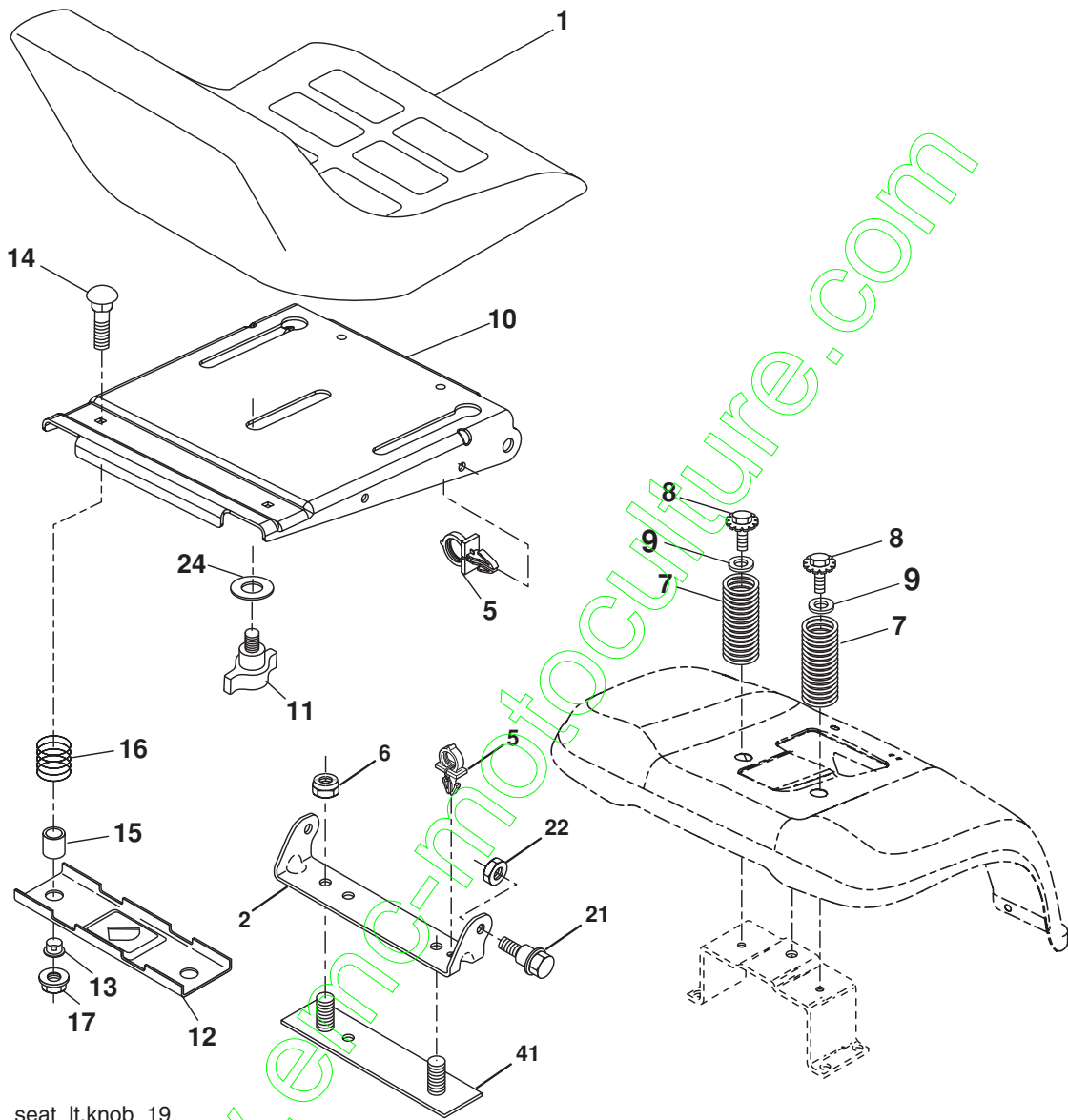

seat\_lt.knob\_19

KEY NO.	PART NO.	DESCRIPTION
1	532 18 87-06	Seat
2	532 18 01-66	Bracket Pivot Seat
6	873 80 06-00	Nut Lock Hex w/Ins. 3/8-16 unc
7	532 12 41-81	Spring Seat Cprsn 2 250 Blk Zi
8	817 00 06-16	Screw 3/8-16 x 1.5 SMGML
9	819 13 16-14	Washer 13/32 x 1 x 14 Ga.
10	532 19 56-96	Pan Seat
11	532 16 63-69	Knob Seat Adj Wingnut
12	532 17 46-48	Bracket Mounting Switch
13	532 12 12-48	Bushing Snap Blk Nyl 50 Id
14	872 05 04-12	Bolt Rdhd Sht Nk 1/4-20 x 1-1/2

KEY NO.	PART NO.	DESCRIPTION
15	532 12 12-49	Spacer Split 28 x 88 Zinc
16	532 12 37-40	Spring Cprsn 1 310 Blk Pnt
17	532 12 39-76	Nut Lock 1/4 Lge Flg Gr. 5 Zinc
21	532 17 18-52	Bolt Shoulder 5/16-18 unc-2A
22	873 80 05-00	Nut Lock 5/16-18
24	819 17 19-12	Washer 17/32 x 1-3/16 x 12 Ga.
41	532 14 06-75	Strap Asm. Fender

**NOTE:** All component dimensions given in U.S. inches  
1 inch = 25.4 mm.

# REPAIR PARTS

TRACTOR - MODEL NO. LT2117A (96011012600), PRODUCT NO. 960 11 01-26  
DECALS

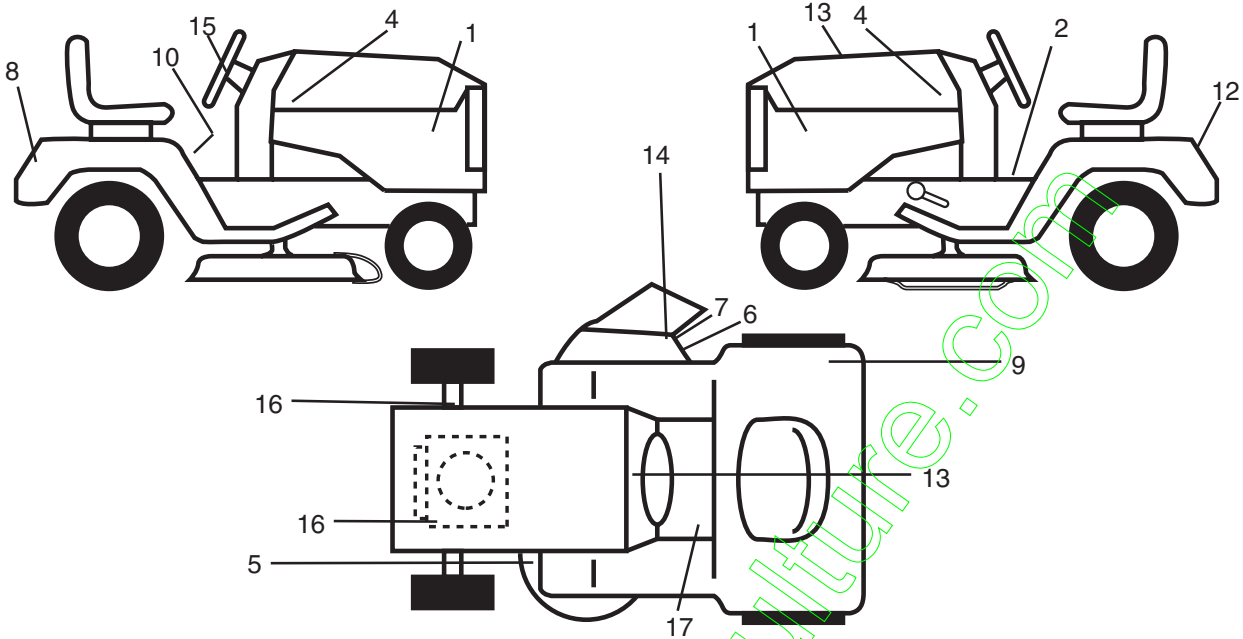

KEY NO.	PART NO.	DESCRIPTION	KEY NO.	PART NO.	DESCRIPTION
1	532 18 88-76	Decal, Side Panel	13	532 18 91-56	Decal, RPL Int
2	532 14 08-37	Decal, Brake Parking Sandle	14	532 17 91-28	Decal, Deck "B" 42"
3	532 18 65-03	Decal, Dash	15	532 18 57-73	Decal, Logo Steering Wheel Cap
4	532 18 95-53	Decal, Hood RH/LH	16	532 15 97-36	Decal, Chassis Hot Muffler
5	532 16 03-96	Decal, V-Belt Sch.	17	532 15 97-37	Decal, Brake/Clutch Symbol LT
6	532 19 63-57	Decal, Warning Cutfinger	--	532 16 25-98	Decal, Drawbar Load Limit
7	532 18 21-66	Decal, Mower Cutfinger Symbol	--	532 16 69-60	Decal, By-Pass
8	532 18 39-30	Decal, Logo, Fender	--	532 18 82-52	Pad, Footrest LH
9	532 18 04-32	Decal, 100 DB/CE	--	532 18 82-53	Pad, Footrest RH
10	532 40 03-89	Decal, Read Owners Manual	--	532 40 09-39	Manual, Operator's (Euro)
11	532 14 50-05	Decal, Bat Dan/Poi P/L Sym	--	532 40 09-40	Manual, Operators, (Scan)
12	532 18 88-36	Decal, Fender	--	532 40 14-77	Manual, Operators, (Ebloc)
			--	532 40 14-78	Manual, Operators, (Baltic)

## WHEELS & TIRES

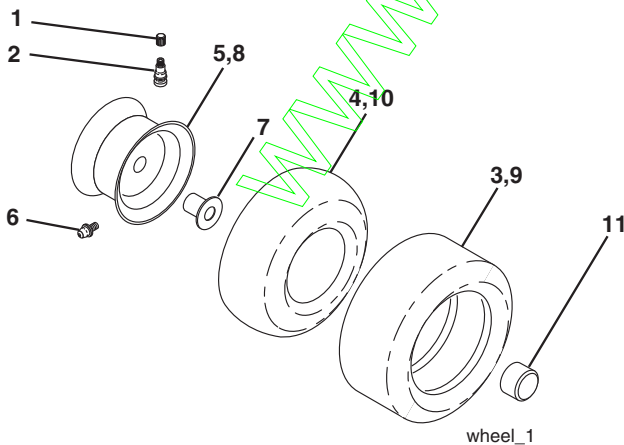

KEY NO.	PART NO.	DESCRIPTION
1	532 05 91-92	Cap Valve Tire
2	532 06 51-39	Stem Valve
3	532 10 62-22	Tire F Ts 15 x 6 0 - 6 Service
4	532 05 99-04	Tube Front (Service Item Only)
5	532 13 83-36	Rim Asm 6"front Silver Service
6	532 12 49-57	Fitting Grease (Front Wheel Only)
7	532 12 49-59	Bearing Flange (Front Wheel Only)
8	532 13 83-37	Rim Asm 8"rear Silver Service
9	532 12 20-82	Tire R Ts 20 x 10-8 C Service
10	532 12 49-26	Tube Rear (Service Item Only)
11	532 17 50-39	Cap Axle Blk 1 50 x 1 00
--	532 14 43-34	Sealant, Tire (10 oz. tube)

**NOTE:** All component dimensions given in U.S. inches  
1 inch = 25.4 mm

# REPAIR PARTS

TRACTOR - MODEL NO. LT2117A (96011012600), PRODUCT NO. 960 11 01-26  
ENGINE

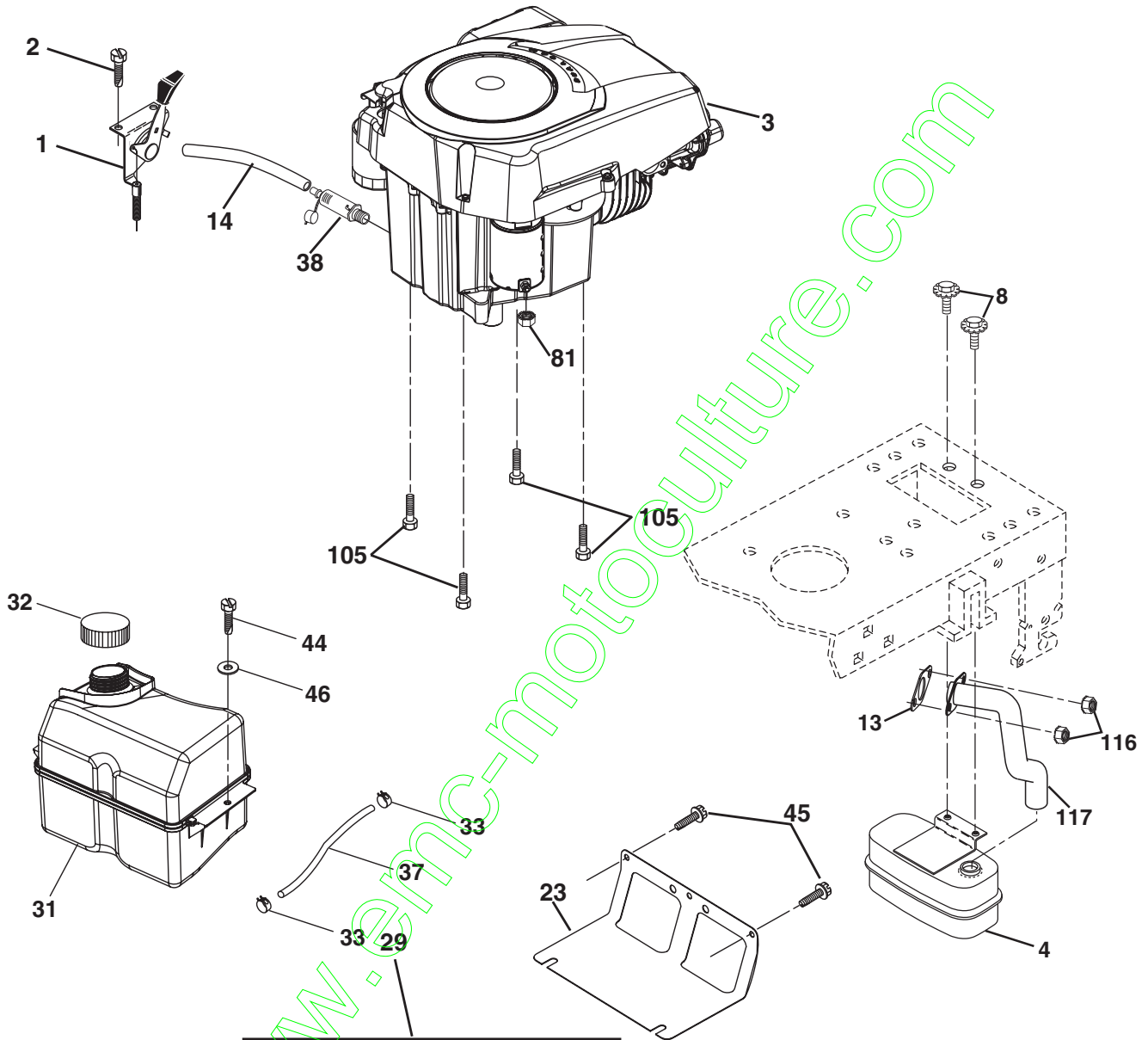

**OPTIONAL EQUIPMENT**  
**Spark Arrester**

# REPAIR PARTS

TRACTOR - MODEL NO. LT2117A (96011012600), PRODUCT NO. 960 11 01-26  
ENGINE

KEY NO.	PART NO.	DESCRIPTION
1	532 40 15-08	Control Th/ch
2	532 19 16-11	Screw 10 x 3/4 Single Lead Hex
3	-----	Engine Kohl Model No. SV530 (Order parts from engine manufacturer)
4	532 18 86-55	Muffler
8	532 17 18-77	Bolt 5/16-18 Unc x 3/4 w/Sems
13	532 18 59-09	Gasket Eng
14	532 14 84-56	Tube Drain Oil Easy
23	532 16 98-37	Shield Browning/Debris Guard
29	532 13 71-80	Kit Spark Arrestor
31	532 18 55-34	Tank Fuel
32	532 14 05-27	Cap Asm Fuel Top Vented N/Lang
33	532 12 34-87	Clamp Hose Black
37	532 13 70-40	Line Fuel
38	532 18 16-54	Plug Drain Oil Easy
44	817 67 04-12	Screw Hex Wsh THDROL 1/4-20 x 3/4
45	817 00 06-12	Screw 3/8-16 x .75 SMGML
46	819 09 14-16	Washer 9/32 x 7/8 x 16 Ga.
81	873 51 04-00	Nut Flange 1/4-20 Starter Nut
105	817 12 06-16	Screw 3/8-16 x 1
116	532 18 43-62	Nut Hex Flange Toplock M8-1.25
117	532 18 86-54	Tube Exhaust

**NOTE:** All component dimensions given in U.S. inches  
1 inch = 25.4 mm

# REPAIR PARTS

TRACTOR - MODEL NO. LT2117A (96011012600), PRODUCT NO. 960 11 01-26  
MOWER DECK

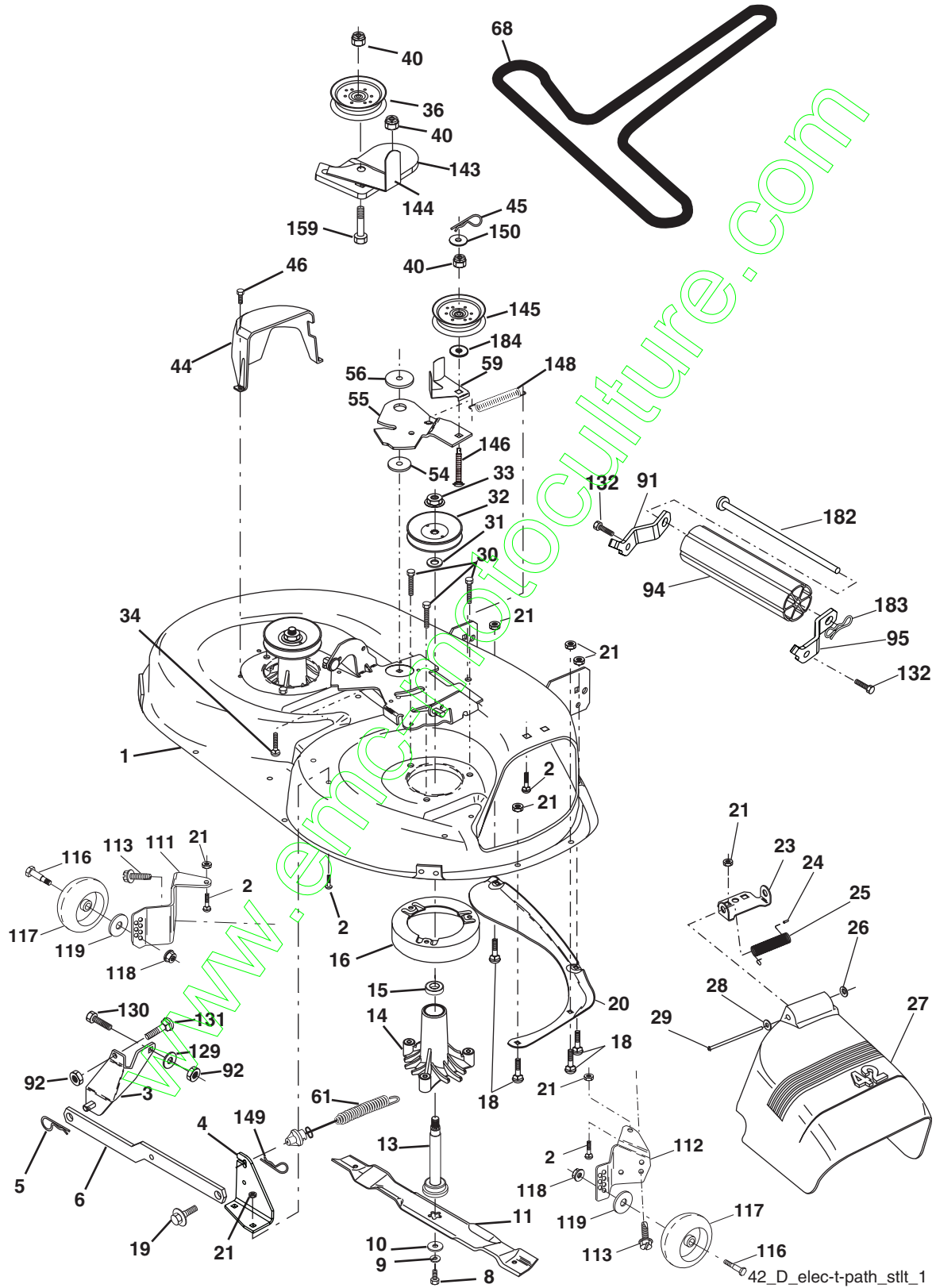



# REPAIR PARTS

**TRACTOR - MODEL NO. LT2117A (96011012600), PRODUCT NO. 960 11 01-26  
MOWER DECK**

KEY NO.	PART NO.	DESCRIPTION	KEY NO.	PART NO.	DESCRIPTION
1	532 16 58-92	Housing Asm Mower 42"94 T-Path	68	532 18 02-60	V-Belt Mower
2	872 14 05-06	Bolt Rdhd Sqnk 5/16-18 Unc x 3/4	91	532 18 05-32	Bracket Asm Noseroller LH
3	532 13 80-17	Bracket Asm Fr Sway Bar 38/42	92	873 80 06-00	Nut Lock Hex w/ins. 3/8-16 Unc
4	532 16 54-60	Bracket Asm Deck 42"sway Bar	94	532 13 22-64	Roller Nose 38 & 42
5	532 12 46-70	Retainer Spring	95	532 18 05-33	Bracket Asm Noseroller RH
6	532 17 80-24	Bar Sway Deck	111	532 17 92-92	Bracket Gauge Wheel Lh
8	532 85 08-57	Bolt 3/8-24 x 1 25 Gr8 Patched	112	532 17 92-93	Bracket Gauge Wheel Rh
9	810 03 06-00	Washer Lock Hvy 3/8 Unplated	113	817 00 05-10	Bolt 5/16-18 Hex Whs HD LCK-SERR
10	532 14 02-96	Washer Hard Blade Mower Vented	116	532 12 48-42	Bolt Shoulder
11	532 13 89-71	Blade Mower High Lift"	117	532 18 86-06	Wheel Gauge
13	532 13 76-45	Shaft Asm W/lower Bearing	118	873 93 06-00	Nut Centerlock 3/8-16 Unc
14	532 12 87-74	Housing Mandrel Vented(machd)	119	819 12 14-14	Washer 3/8 x 7/8 x 14 Ga.
15	532 11 04-85	Bearing Ball Mandrel	129	819 13 13-12	Washer 13/32 x 13/16 x 12 Ga.
16	532 17 44-93	Stripper Mower	130	874 78 06-16	Bolt Fin Hex 3/8-16 Unc x 1 Gr. 5
18	872 14 05-05	Bolt Carr 5/16-18 x 5/8	131	872 14 06-08	Bolt Rdhd Sqnk 3/8-16 Unc x1
19	532 13 28-27	Bolt Shoulder	132	817 00 06-12	Screw 3/8-16 x .75
20	532 15 97-70	Baffle Vortex 42	143	532 15 71-09	Bracket Arm Idler
21	873 68 05-00	Nut Crown Lock 5/16-18	144	532 15 86-34	Keeper Belt
23	532 17 75-63	Bracket Deflector Mower 42"	145	532 16 58-88	Pulley Idler Flat
24	532 10 53-04	Cap Sleeve 80x 112 Blk Mower	146	532 17 19-77	Bolt Carriage Idler
25	532 12 37-13	Spring Torsion Deflector 2 52	148	532 16 90-22	Spring Return Idler
26	532 11 04-52	Nut Push Phos & Oil	149	532 16 58-98	Retainer Spring Yellow
27	532 17 18-59	Shield Deflector	150	819 09 12-10	Washer 9/32 x 3/4 x 10
28	819 11 10-16	Washer 11/32 x 5/8 x 16 Ga	159	872 14 06-14	Bolt RDHD SQN 3/8-16 x 1-3/4
29	532 13 14-91	Rod Hinge 42"6 75 Wlg	182	532 17 91-26	Rod Roller Nose Standard
30	532 17 39-84	Screw Thd Rolling Hex	183	532 19 42-09	Retainer Spring
31	532 18 76-90	Washer Spacer	184	819 13 14-10	Washer 13/32 x 7/8 x 10 Ga.
32	532 15 35-35	Pulley Mandrel	--	532 13 07-94	Mandrel Assembly (Includes Housing, Shaft and Shaft Hardware Only - Pulley Not Included)
33	532 17 83-42	Nut 9/16top Lock Flng Cntr	--	532 18 19-62	Replacement Deck, Complete (Std. Deck - Order separately nose roller and gauge wheel components key nos. 91, 94-95, 132, 182, 183, 116-119)
34	872 11 06-12	Bolt Carr Sh 3/8-16 x 1-1/2 Gr.5			
36	532 13 14-94	Pulley Idler Flat 3 060			
40	873 90 06-00	Nut Lock 3/8-16 Unc			
44	532 14 00-88	Guard Mandrel LH Black			
45	532 12 47-88	Retainer Spring			
46	532 13 77-29	Screw Thdrol 1/4-20 x 5/8			
54	532 17 85-15	Washer Hardened			
55	532 15 50-46	Arm Idler 42"mower LT/YT			
56	532 16 57-23	Spacer Retainer Mower			
59	532 14 10-43	Guard, Belt			
61	532 17 48-82	Spring Ext. Elect			

**NOTE:** All component dimensions given in U.S. inches  
1 inch = 25.4 mm

# REPAIR PARTS

TRACTOR - MODEL NO. LT2117A (96011012600), PRODUCT NO. 960 11 01-26  
MOWER LIFT

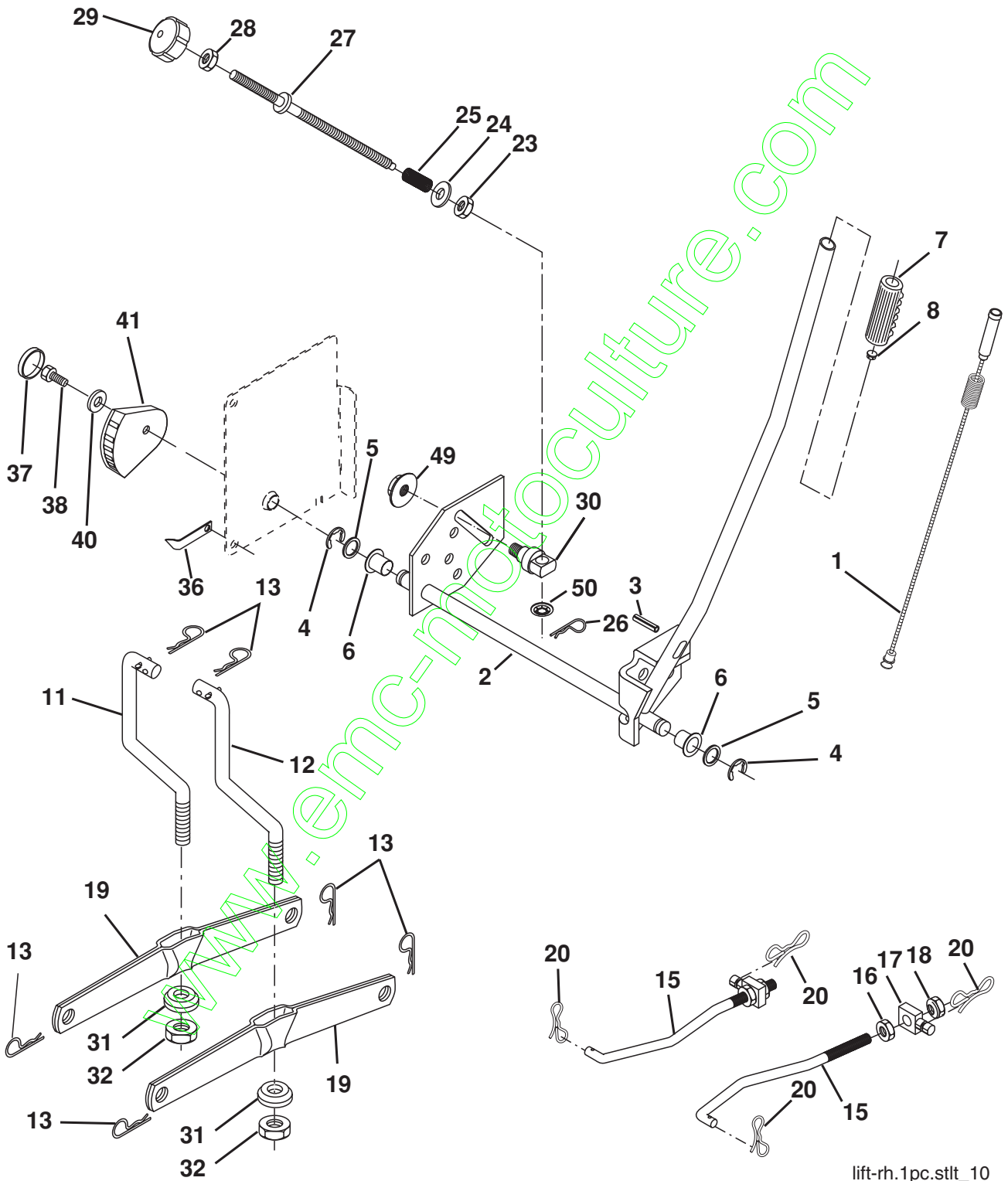

lift-rh.1pc.stlt\_10

# REPAIR PARTS

TRACTOR - MODEL NO. LT2117A (96011012600), PRODUCT NO. 960 11 01-26  
MOWER LIFT

KEY NO.	PART NO.	DESCRIPTION
1	532 19 84-17	Wire Asm Inner/Sprg W/plunger LT
2	532 19 80-70	Shaft Asm Lift
3	532 18 88-22	Pin Groove
4	812 00 00-02	E Ring #5133-62
5	819 21 16-21	Washer 21/32 x 1 x 21 Ga.
6	532 12 01-83	Bearing Nylon Blk 629 Id
7	532 12 56-31	Grip Handle Fluted Blk
8	532 12 23-65	Button Plunger Red
11	532 13 98-65	Link Lift LH Mower
12	532 13 98-66	Link Lift RH Mower
13	532 12 46-70	Retainer Spring
15	532 17 32-88	Link Front
16	873 35 08-00	Nut Jam Hex 1/2-13 Unc
17	532 17 56-89	Trunnion Blk Zinc
18	873 80 08-00	Nut Lock W/wsh 1/2-13 Unc
19	532 13 98-68	Arm Suspension Rear
20	532 19 42-09	Pin Cotter 7/16 Bow Tie Lock
23	532 11 08-07	Nut Special
24	819 13 10-16	Washer 13/32 x 5/8 x 16 Ga.
25	532 16 40-24	Spring Comp Infinite
26	532 16 94-84	Retainer Clip
27	532 16 45-43	Rod Adj Lift
28	873 35 06-00	Nut Hex Jam 3/8-16 Unc
29	532 13 80-57	Knob Inf 3/8-16 Unc
30	532 15 02-33	Trunnion Inf. Height
31	532 16 98-65	Bearing Put Lift
32	873 54 06-00	Nut Crownlock 3/8-24
36	532 15 50-97	Pointer Height Ind
37	532 12 39-35	Plug Hole
38	817 06 05-16	Screw 5/16-18 x 1 SMGML Tap/R
40	819 11 24-10	Washer 11/32 x 1-1/2 x 10 Ga.
41	532 15 50-98	Ind Height STLT
49	532 14 52-12	Nut, Hex Flange Lock
50	532 11 04-52	Nut Push Phos & Oil

**NOTE:** All component dimensions given in U.S. inches  
1 inch = 25.4 mm