

LT2118 A

Spare parts
Ersatzteile
Pièces détachées
Reserve onderdelen
Repuestos
Reservdelar

www.emc-motoculture.com

TRACTOR - MODEL NO. LT2118A (96011001000), PRODUCT NO. 954 13 02-13 SCHEMATIC

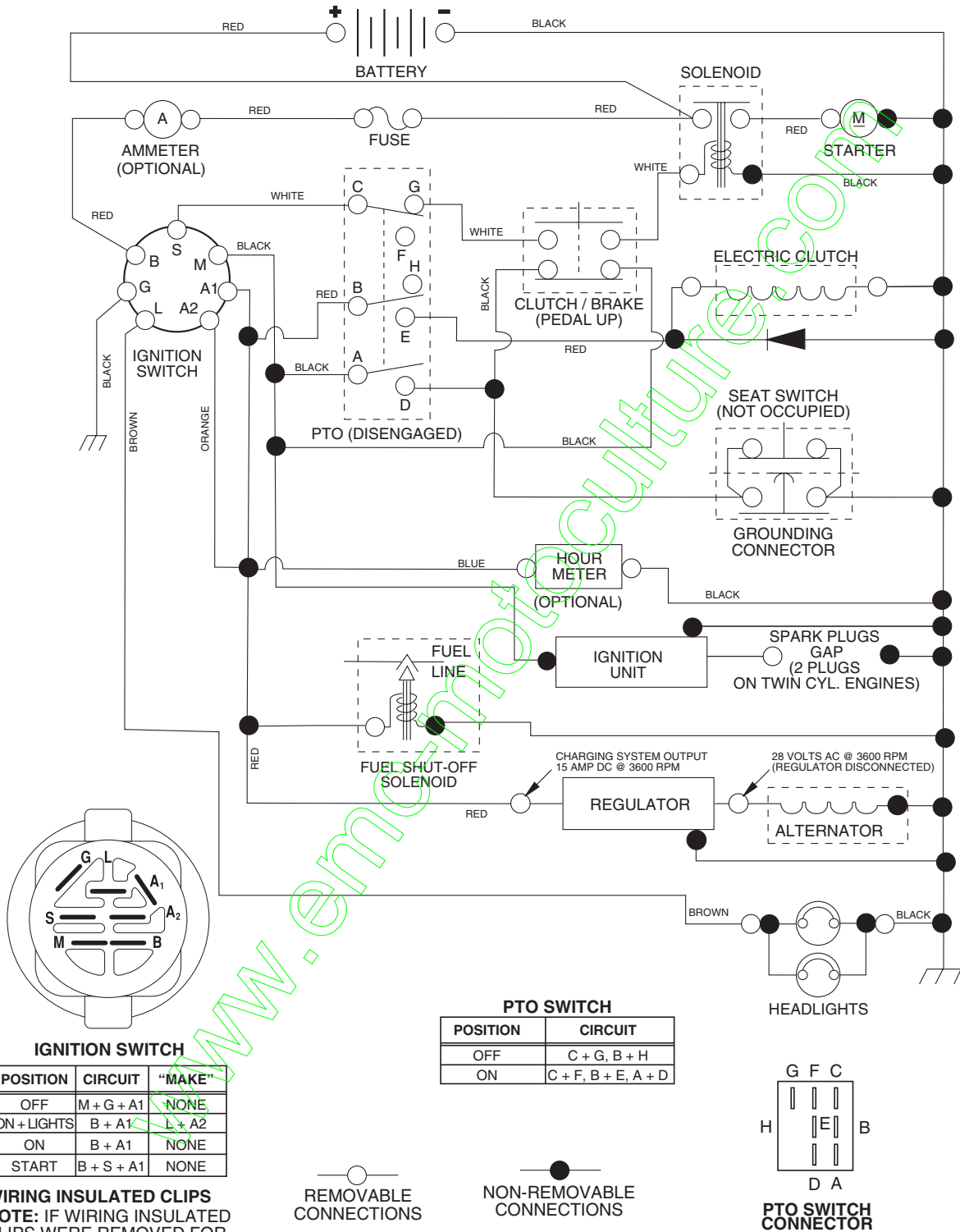

WIRING INSULATED CLIPS
NOTE: IF WIRING INSULATED CLIPS WERE REMOVED FOR SERVICING OF UNIT, THEY SHOULD BE REPLACED TO PROPERLY SECURE YOUR WIRING.

REPAIR PARTS

TRACTOR - MODEL NO. LT2118A (96011001000), PRODUCT NO. 954 13 02-13
ELECTRICAL

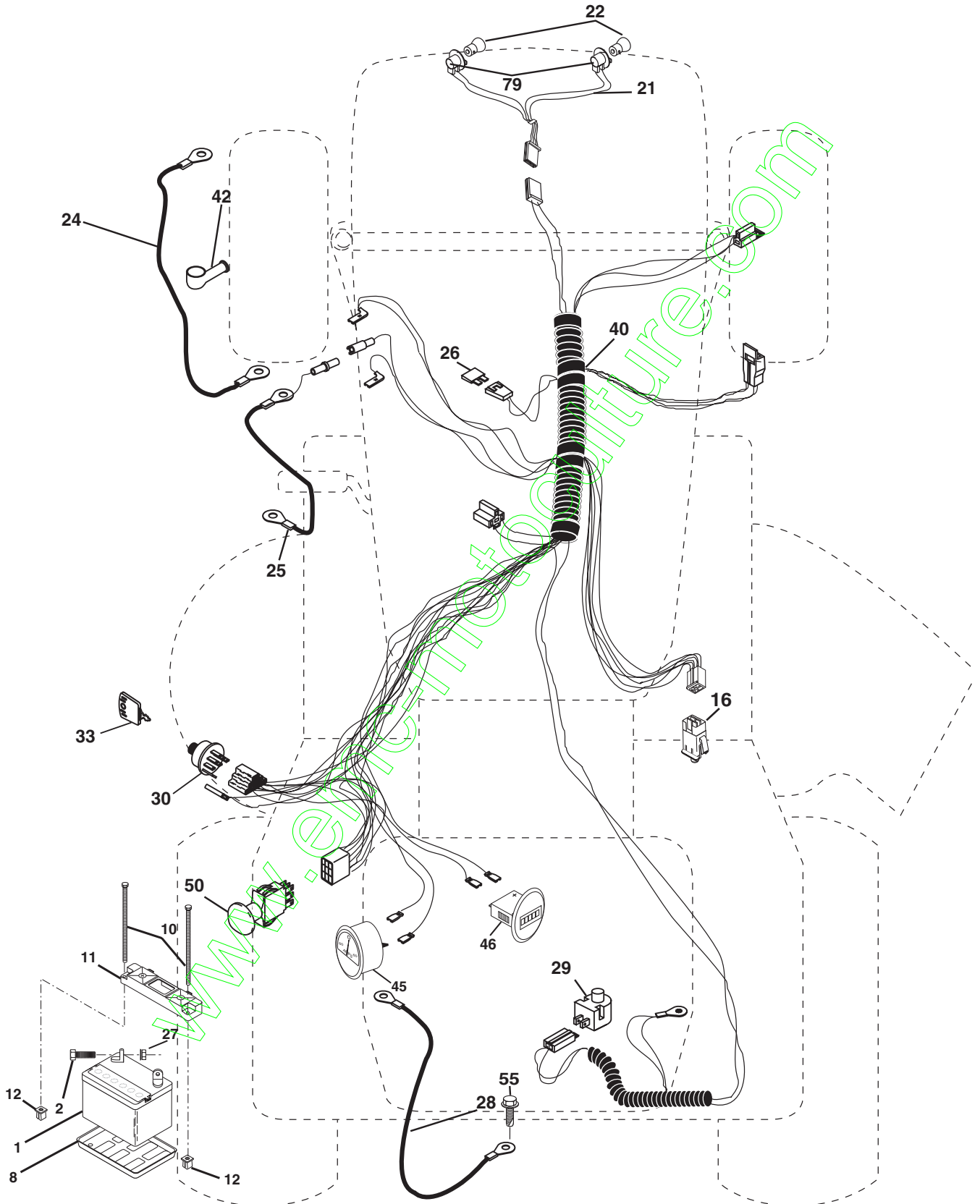

REPAIR PARTS

TRACTOR - MODEL NO. LT2118A (96011001000), PRODUCT NO. 954 13 02-13
ELECTRICAL

KEY NO.	PART NO.	DESCRIPTION
1	532 14 49-27	Battery
2	874 76 04-12	Bolt Hex Hd 1/4-20 Unc x 3/4
8	532 12 48-86	Tray Battery 7.80 x 5.25
10	532 14 52-11	Bolt Btr Frt 1/4-20 x 7.5
11	532 15 01-09	Holddown Battery Front
12	532 14 57-69	Nut Push Nylon 1/4
16	532 17 61-38	Switch Interlock Push-In
21	532 17 56-88	Harness Asm Light W/4152J
22	532 00 41-52	Bulb Light #1156
24	532 00 88-60	Cable Battery 6 Ga 11"red
25	532 18 68-46	Cable Battery 6 Ga W/pos wire
26	532 17 51-58	Fuse 20 AMP
27	873 51 04-00	Nut Keps Hex 1/4-20 Unc
28	532 14 54-91	Cable Ground
29	532 16 07-84	Switch Plunger Normal Op Olive
30	532 17 55-66	Switch Ignition Delta Push-In
33	532 14 04-01	Key Ign Molded Generic Delta
40	532 18 80-30	Harness Ign.
42	532 15 43-36	Cover Terminal Red
45	532 17 75-00	Ammeter Round Delta
46	532 17 75-01	Hourmeter Round Delta
50	532 17 46-51	Switch PTO
55	817 49 05-08	Screw Thdrol 5/16-18 x 1/2
79	532 17 52-42	Bulb Holder Asm

NOTE: All component dimensions given in U.S. inches
1 inch = 25.4 mm.

REPAIR PARTS

TRACTOR - MODEL NO. LT2118A (96011001000), PRODUCT NO. 954 13 02-13
CHASSIS AND ENCLOSURES

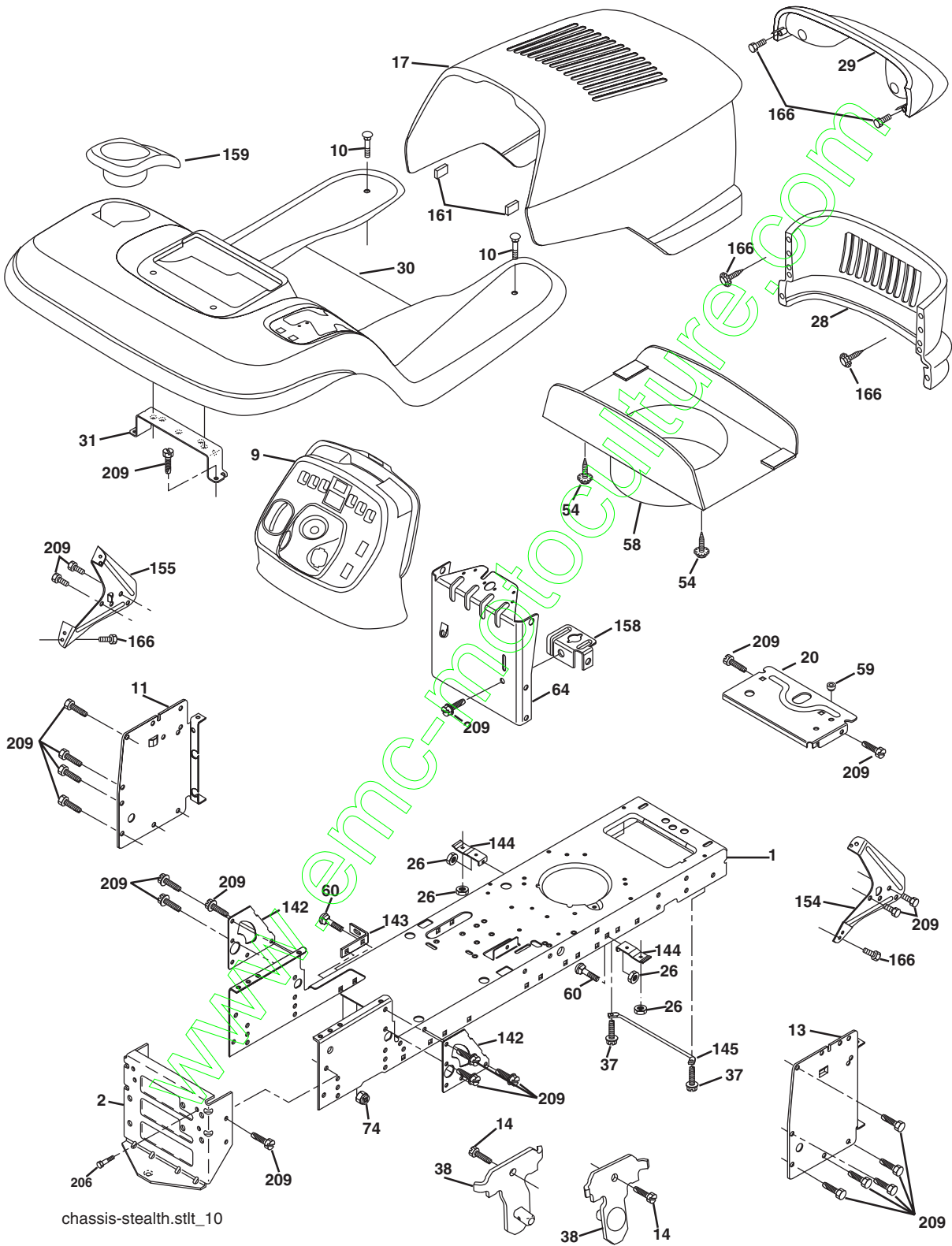

chassis-stealth.stlt_10

REPAIR PARTS

TRACTOR - MODEL NO. LT2118A (96011001000), PRODUCT NO. 954 13 02-13
CHASSIS AND ENCLOSURES

KEY NO.	PART NO.	DESCRIPTION
1	532 17 46-19	Chassis Wldmt.
2	532 17 65-54	Drawbar 12 Ga
9	532 19 13-39	Dash
10	872 14 06-08	Bolt RdHd Sqnk. 3/8-16 x 1
11	532 16 72-03	Panel Asm. Dash Lh
13	532 17 82-98	Panel Dash Rh
14	817 49 06-08	Screw Thdrol 3/8-16 x 1/2
17	532 18 13-51	Hood Pnt
20	532 16 20-26	Plate Mtg Battery
26	873 80 06-00	Nut Lock Hex w/Ins 3/8-16 Unc
28	532 18 13-52	Grill w/Clips
29	532 17 97-61	Lens Grille
30	532 18 13-53	Fender /Ftrest Pnt STL
31	532 13 99-76	Bracket Fender
37	817 49 05-08	Screw Thdrol 5/16-18 x 1/2
38	532 17 57-10	Bracket Asm. Pvt. Mwr. Rear
54	532 16 14-64	Screw Hex Wshd 8-18 x 7/8
58	532 17 53-51	Duct Air
59	532 18 74-95	Bushing Snap Split
60	872 14 06-06	Bolt Rdhd Sqnk 3/8-16 Unc x 3/4
64	532 17 49-97	Dash Lower
74	873 68 06-00	Nut, Crownlock 3/8-16 Unc
142	532 17 57-02	Plate Reinforcement STLT
143	532 18 66-89	Bracket Sway Bar
144	532 17 55-82	Bracket Footrest STLT
145	532 15 65-24	Rod Pivot Chassis/Hood
154	532 16 18-97	Bracket Dash STL RH
155	532 16 19-00	Bracket Dash STL LH
158	532 16 20-37	Bracket Parking Brake
159	532 18 13-55	Cupholder
161	532 16 46-55	Extrusion Bumper
166	532 17 18-75	Screw HWHD Hi Lo 13-16 x 3/4
206	532 17 01-65	Bolt Shoulder 5/16-18
209	817 00 06-12	Screw Hexwsh Thdr 3/8-16 x 3/4
--	532 18 78-01	Plug Dome

NOTE: All component dimensions given in U. S. inches
1 inch = 25.4 mm

REPAIR PARTS

TRACTOR - MODEL NO. LT2118A (96011001000), PRODUCT NO. 954 13 02-13
DRIVE

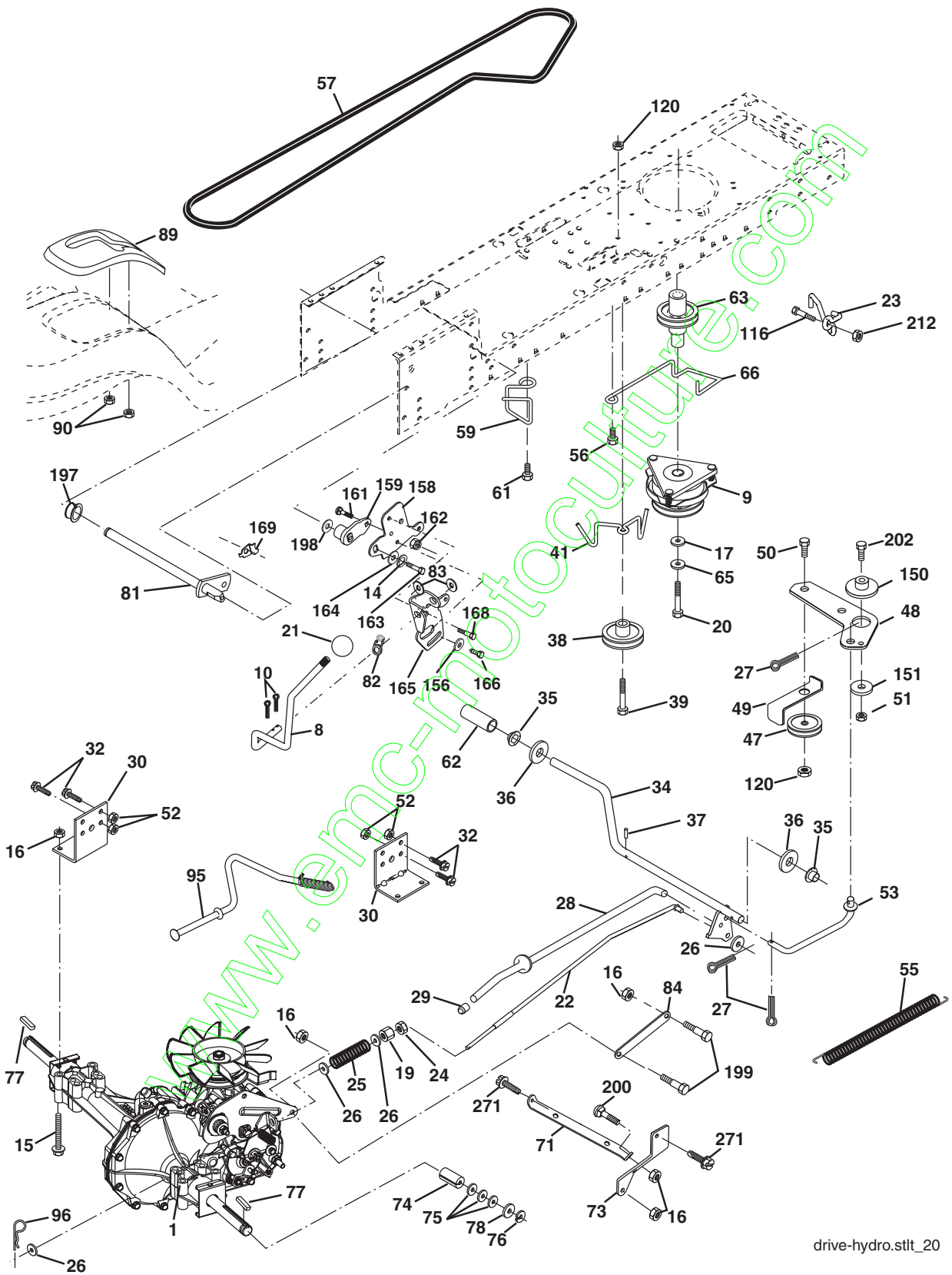

drive-hydro.stlt_20

REPAIR PARTS

**TRACTOR - MODEL NO. LT2118A (96011001000), PRODUCT NO. 954 13 02-13
DRIVE**

KEY NO.	PART NO.	DESCRIPTION	KEY NO.	PART NO.	DESCRIPTION
1	-----	Transaxle Hydro Gear 314-0510	63	532 17 46-07	Pulley, Engine
		Order parts from transaxle manufacturer	65	810 04 07-00	Washer
8	532 16 58-66	Rod Shift Fender	66	532 15 47-78	Keeper Belt Engine Hydro
9	532 18 02-20	Clutch Electric	71	532 16 91-83	Strap Torque Lh Hydro
10	876 02 04-16	Pin Cotter 1/8 x 1 CAD	73	532 16 91-82	Strap Torque Rh Hydro
14	810 04 04-00	Washer Lock Hvy Helical	74	532 13 70-57	Spacer, Axle
15	874 49 05-44	Bolt Hex Flghd. 5/16-18 Gr.5	75	532 12 17-49	Washer 25/32 x 1-1/4 x 16 Ga.
16	873 80 05-00	Nut Lock Hex W/Ins. 5/16-18 Unc P	76	812 00 00-01	E-Ring
			77	532 12 35-83	Key, Square
17	532 12 61-97	Washer 1-1/2 OD x 15/32 ID x .250	78	532 12 17-48	Washer 25/32 x 1-5/8 x 16 Ga.
			81	532 16 55-96	Shaft Asm Cross Tapered 510 20"
19	873 80 06-00	Nut Lock Hex W/Wsh 3/8-16 Unc	82	532 16 57-11	Spring Torsion T/A
			83	819 17 12-16	Washer 17/32 x 3/4 x 16 Ga.
20	532 17 39-37	Bolt, Hex 7/16-20 x 4 x Gr. 5-1.5	84	532 16 95-94	Link Transaxle HB-0510
21	532 13 05-64	Knob Deluxe	89	532 16 66-02	Console, Shift
22	532 16 94-98	Rod, Brake Hydro	90	532 12 43-46	Nut, Self Thd Wsh Hd 1/4 Zinc
23	532 17 82-89	Bracket Asm Anti Rot	95	532 17 02-01	Control Asm. Bypass Hydro
24	873 35 06-00	Locknut	96	532 12 47-88	Retainer Spring 1" Zinc/Cad
25	532 10 68-88	Spring, Brake Rod	116	872 14 06-08	Bolt RdHd Sqnk 3/8-16 Unc x 1
26	819 13 13-16	Washer	120	873 90 06-00	Nut Lock Flg 3/8-16
27	876 02 04-12	Pin Cotter 1/8 x 3/4 CAD.	150	532 17 54-56	Spacer Retainer
28	532 17 57-65	Rod, Parking Brake	151	819 13 32-10	Washer 13/32 x 2 x 10 Ga.
29	532 07 16-73	Cap, Parking Brake	156	532 16 60-02	Washer Srrted 5/16ID x 1.125
30	532 16 95-92	Bracket, Transaxle	158	532 16 55-89	Bracket Shift Mount
32	874 76 05-12	Bolt Hex Hd 5/16-18 Unc x 3/4	159	532 18 39-00	Hub Shift
34	532 17 55-78	Shaft, Foot Pedal	161	872 14 04-06	Bolt Rdhd Sqnk 1/4-20 x 3/4 Gr 5
35	532 12 01-83	Bearing, Nylon			Nut Crownlock 1/4-20 Unc
36	819 21 16-16	Washer	162	873 68 04-00	Bolt Hex Fin 1/4-20 Unc x 1 Gr 5
37	532 12 49-63	Pin, Roll	163	874 78 04-16	Washer 9/32 x 3/4 x 10 Ga.
38	532 17 91-14	Pulley, Composite, Flat			Bracket Pivot Lever
39	872 11 06-22	Bolt RDHD 3/8-16 UNC x 2-3/4 Gr. 5	164	819 09 12-10	Screw 5/16-18 x 5/8
			165	532 16 56-23	Bolt Shoulxder 5/16-18 x .561
41	532 17 55-56	Keeper, Belt Idler Flat	166	817 49 05-10	Plate Fasteneing Lt
47	532 12 77-83	Pulley, Idler, V-Groove	168	532 16 54-92	Nylinder Snap-In
48	532 15 44-07	Bellcrank Grnd Clutch	169	532 16 55-80	Washer Nyl. 7/8 ID x .105"
49	532 12 32-05	Retainer, Belt	197	532 16 96-13	Bolt Shoulder 5/16-18
50	872 11 06-12	Bolt Carr. Sh. 3/8-16 x 1-1/2 Gr. 5	198	532 16 95-93	Bolt Rdhd Sqnk 5/16-18 x 1
			199	532 16 96-12	Bolt Rdhd 3/8-16 x 1-3/4 Gr 5
51	873 68 06-00	Nut	200	872 14 05-08	Nut Hex Flange Lock
52	873 68 05-00	Nut Crown Lock 5/16-18	202	872 11 06-14	Screw Hex Wsh Thdr 3/8-16 x 3/4 BL
53	532 10 57-10	Link, Clutch	212	532 14 52-12	
55	532 10 57-09	Spring, Return, Clutch	271	817 00 06-12	
56	817 06 06-20	Screw 3/8-16 x 1-1/4			
57	532 14 02-94	V-Belt, Ground Drive			
59	532 16 96-91	Keeper, Center Span			
61	817 12 06-14	Screw 3/8-16 x .875 SMGML Tap/R.Z			
62	532 12 48-72	Cover, Pedal			

NOTE: All component dimensions given in U.S. inches
1 inch = 25.4 mm.

REPAIR PARTS

TRACTOR - MODEL NO. LT2118A (96011001000), PRODUCT NO. 954 13 02-13
STEERING ASSEMBLY

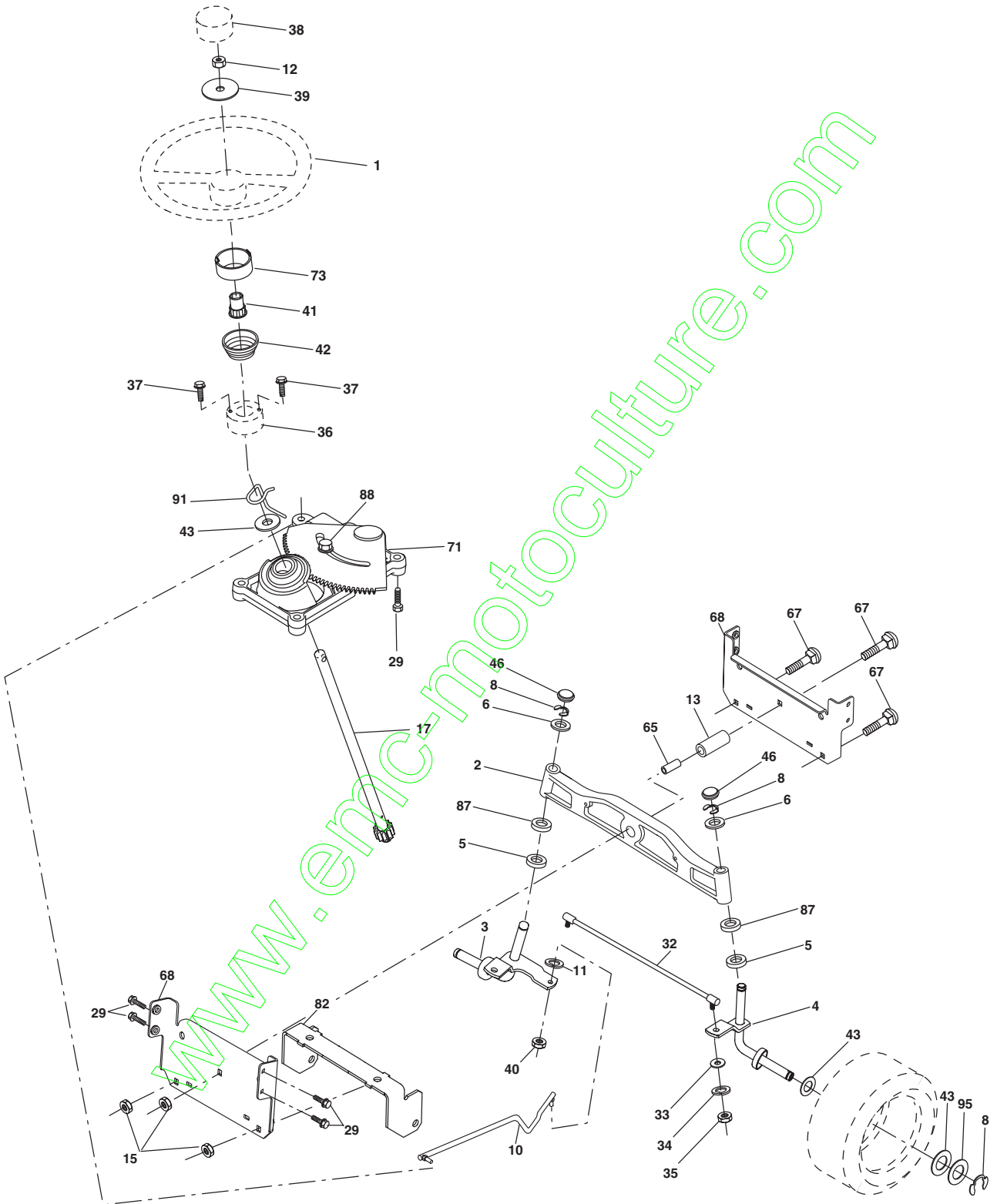

steering_stealth_prem_3

REPAIR PARTS

TRACTOR - MODEL NO. LT2118A (96011001000), PRODUCT NO. 954 13 02-13
STEERING ASSEMBLY

KEY NO.	PART NO.	DESCRIPTION
1	532 17 20-92	Wheel Steering
2	532 18 47-06	Axle Front Cast Iron
3	532 16 98-40	Spindle Asm LH
4	532 16 98-39	Spindle Asm Stmp RH
5	532 12 49-31	Bearing Race Thrust Harden
6	532 12 17-48	Washer 25/32 x 1-5/8 x 16 Ga
8	812 00 00-29	Ring Klip #t5304-75
10	532 17 51-21	Link Drag
11	810 04 06-00	Washer Lock Hvy Hlcl Spr 3/8
12	873 94 08-00	Nut Hex Jam Top Lock 1/2-20
13	532 13 65-18	Spacer Bearing Axle Front
15	532 14 52-12	Nut Hex Flange Lock
17	532 17 78-83	Shaft Asm Strg
29	817 00 06-12	Screw 3/8-16 X .75 SMGML
32	532 17 18-88	Rod Asm Tie Ball J Solid
33	819 11 12-16	Washer 11/32 x 3/4 x 16 Ga.
34	810 04 05-00	Washer Lock Hvy HLCL Spr. 5/16
35	873 54 05-00	Nut Crown Lock 5/16-24
36	532 15 51-05	Bushing Strg
37	532 15 29-27	Screw TT #32.5 x 5 x 3/8 Flange
38	532 17 20-93	Cap Wheel Steer
39	819 18 24-11	Washer 9/16 ID x 1 1/2 OD. 11 G. Zin
40	873 54 06-00	Nut Crownlock 3/8-24
41	532 15 99-45	Adaptor Wheel Strg
42	532 17 71-49	Boot Dash Steering
43	532 12 17-49	Washer 25/32 x 1-1/4 x 16 Ga
46	532 12 12-32	Cap Spindle Fr Top Blk
65	532 16 03-67	Spacer
67	872 11 06-18	Bolt Rdhd Sqnk 3/8-16 x 2-1/4
68	532 16 98-27	Brace, Axle
71	532 17 51-46	Steering Asm
73	532 18 14-49	Extension Steering
82	532 16 98-35	Bracket Susp Chassis
87	532 17 39-66	Washer Flat .781 x 1-1/2 x .14
88	532 17 51-18	Bolt Shoulder 7/16-20
91	532 17 55-53	Clip Steering
95	532 18 89-67	Washer Harden .793 x 1 .637 x 060

NOTE: All component dimensions given in U.S. inches
1 inch = 25.4 mm.

REPAIR PARTS

TRACTOR - MODEL NO. LT2118A (96011001000), PRODUCT NO. 954 13 02-13
SEAT ASSEMBLY

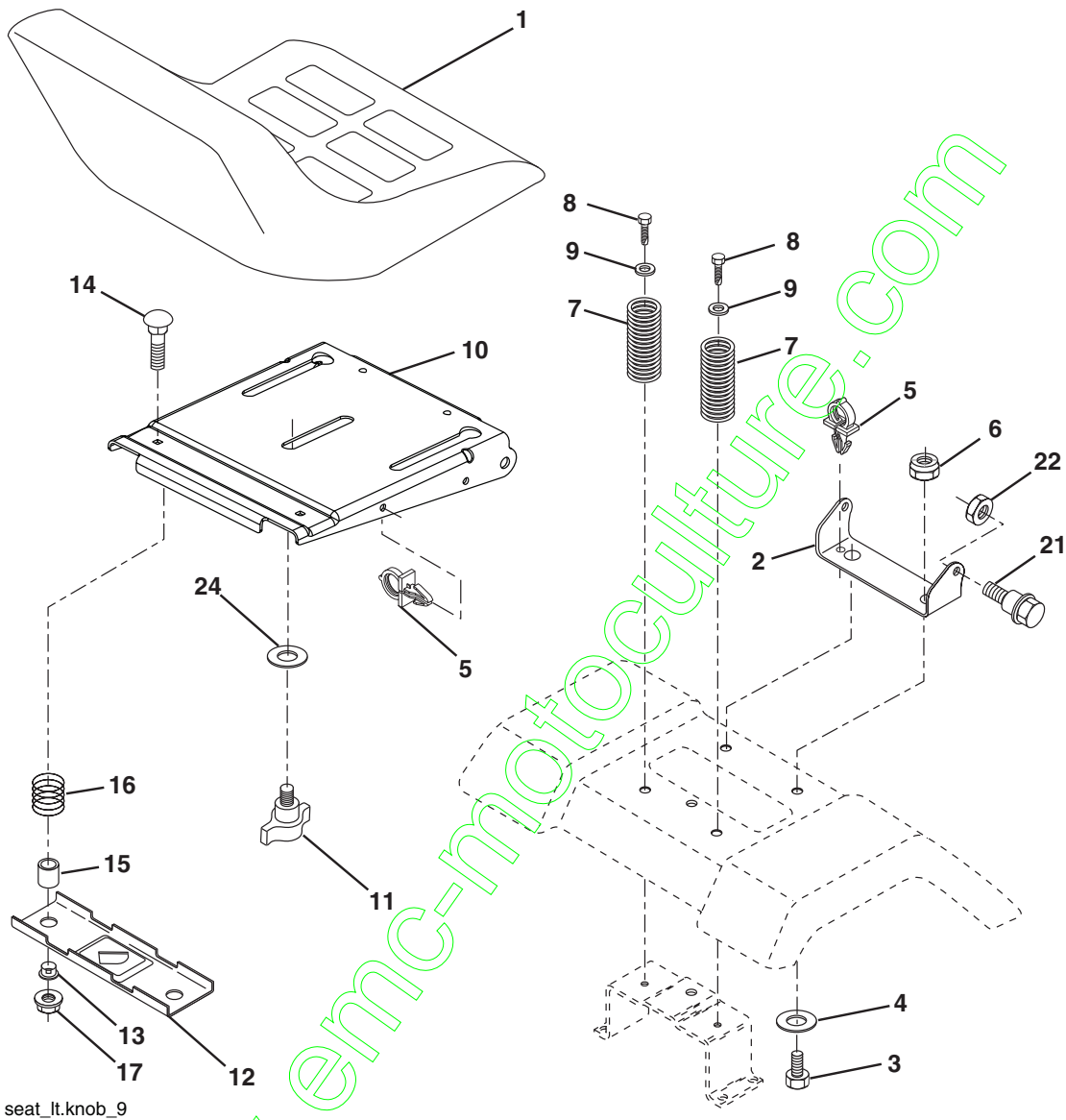

KEY NO.	PART NO.	DESCRIPTION
1	532 18 87-06	Seat
2	532 18 01-66	Bracket Pivot
3	871 11 06-16	Bolt Hex 3/8-16unc x 1
4	819 13 16-10	Washer 13/32 x 1 x 10 Ga
5	532 14 50-06	Clip Push-In Hinged
6	873 80 06-00	Nut Lock Hex w/Ins. 3/8-16 Unc
7	532 12 41-81	Spring Seat Cprsn 2 250 Blk Zi
8	817 00 06-16	Screw 3/8-16 x 1.5 SMGML
9	819 13 16-14	Washer 13/32 x 1 x 14 Ga
10	532 18 01-86	Pan Seat
11	532 16 63-69	Knob Seat Adj Wingnut

KEY NO.	PART NO.	DESCRIPTION
12	532 12 12-46	Bracket Mounting Switch
13	532 12 12-48	Bushing Snap Blk Nyl 50 Id
14	872 05 04-12	Bolt Rdhd Sht Nk 1/4-20 x 1-1/2
15	532 12 12-49	Spacer Split 28x 88 Zinc
16	532 12 37-40	Spring Cprsn 1 310 Blk Pnt
17	532 12 39-76	Nut Lock 1/4 Lge Flg Gr 5 Zinc
21	532 17 18-52	Bolt Shoulder 5/16-18 Unc-2A
22	873 80 05-00	Nut Lock 5/16-18
24	819 17 19-12	Washer 17/32 x 1-3/16 x 12 Ga

NOTE: All component dimensions given in U.S. inches
1 inch = 25.4 mm.

REPAIR PARTS

TRACTOR - MODEL NO. LT2118A (96011001000), PRODUCT NO. 954 13 02-13
DECALS

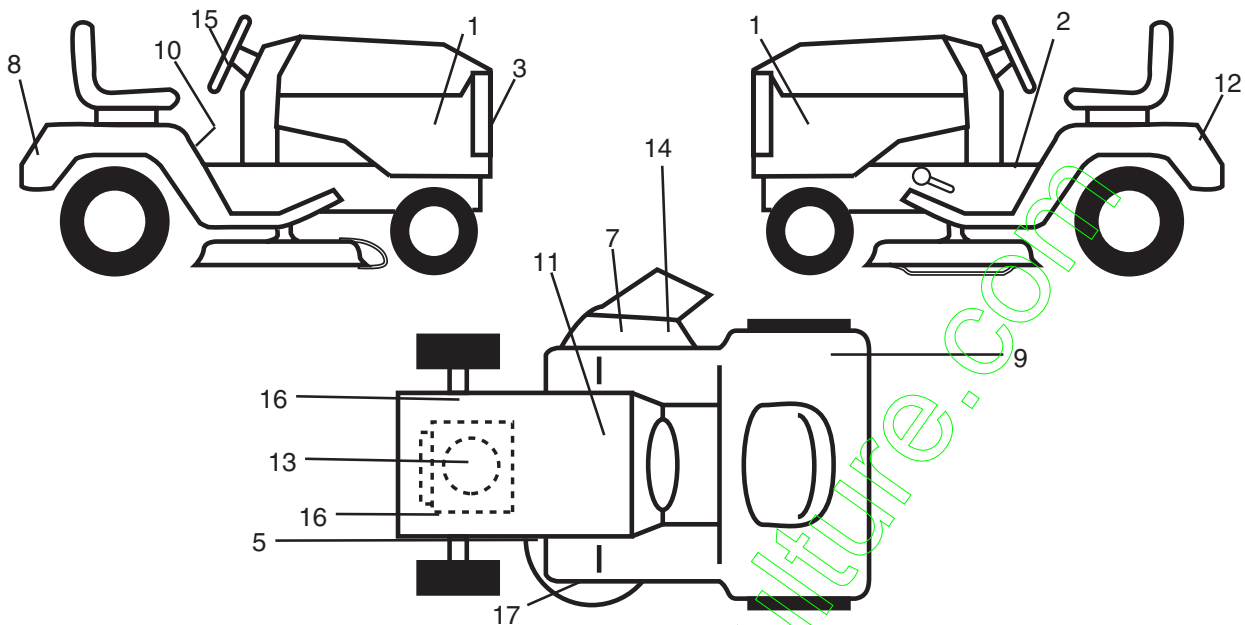

KEY NO.	PART NO.	DESCRIPTION	KEY NO.	PART NO.	DESCRIPTION
1	532 18 88-76	Decal Hood Side Panel	14	532 17 91-28	Decal, Deck "B" 42"
2	532 14 08-37	Decal, Brake Parking Sandle	15	532 18 57-73	Decal, Logo Steering Wheel Cap
5	532 16 03-96	Decal, V-Belt Sch.	16	532 15 97-36	Decal, Chassis Hot Muffler
7	532 18 21-66	Decal, Mower Cutfingher Symbol	17	532 15 97-37	Decal, Brake/Clutch Symbol LT
8	532 18 39-30	Decal, Logo, Fender	--	532 16 25-98	Decal, Drawbar Load Limit
9	532 18 04-32	Decal, 100 DB/CE	--	532 16 69-60	Decal, By-Pass Lt Hydro
10	532 14 54-98	Decal, Read Owners Manual	--	532 18 82-52	Pad, Footrest LH
11	532 14 50-05	Decal, Bat Dan/Poi P/L Sym	--	532 18 82-53	Pad, Footrest RH
12	532 18 88-37	Decal, Fender	--	532 19 44-63	Manual, Operator's (Euro)
13	532 18 91-54	Decal Engine	--	532 19 44-64	Manual, Operators, (Scan)

WHEELS & TIRES

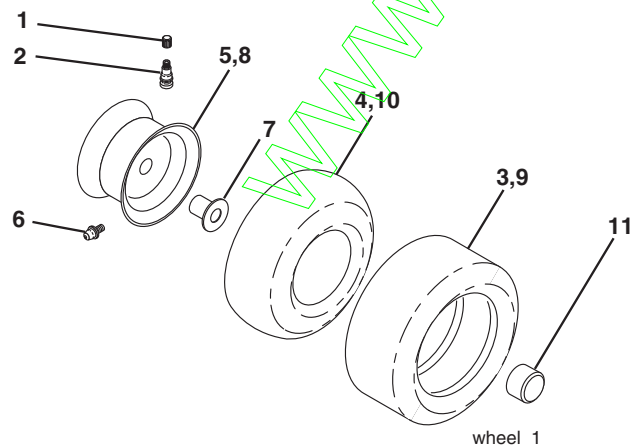

KEY NO.	PART NO.	DESCRIPTION
1	532 05 91-92	Cap Valve Tire
2	532 06 51-39	Stem Valve
3	532 10 62-22	Tire F Ts 15 x 6 0 - 6 Service
4	532 05 99-04	Tube Front (Service Item Only)
5	532 13 83-36	Rim Asm 6"front Silver Service
6	532 12 49-57	Fitting Grease (Front Wheel Only)
7	532 12 49-59	Bearing Flange (Front Wheel Only)
8	532 13 83-37	Rim Asm 8"rear Silver Service
9	532 12 20-82	Tire R Ts 20 x 10-8 C Service
10	532 12 49-26	Tube Rear (Service Item Only)
11	532 17 50-39	Cap Axle Blk 1 50 x 1 00
--	532 14 43-34	Sealant, Tire (10 oz. tube)

NOTE: All component dimensions given in U.S. inches
1 inch = 25.4 mm

REPAIR PARTS

TRACTOR - MODEL NO. LT2118A (96011001000), PRODUCT NO. 954 13 02-13
ENGINE

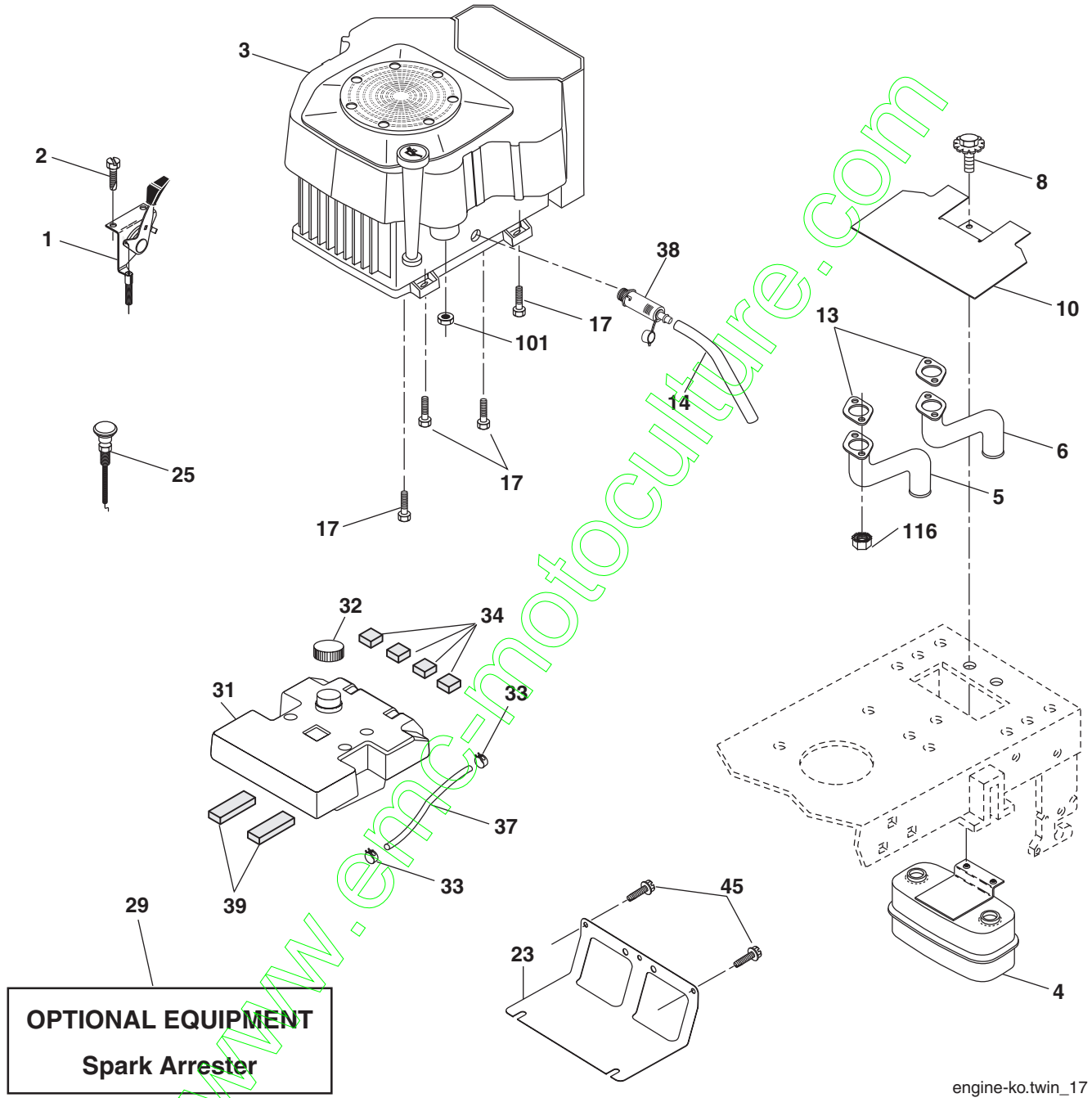

engine-ko.twin_17

REPAIR PARTS

TRACTOR - MODEL NO. LT2118A (96011001000), PRODUCT NO. 954 13 02-13
ENGINE

KEY NO.	PART NO.	DESCRIPTION
1	532 17 81-47	Control Th/ch CB EEC. 428
2	532 17 18-75	Screw HWHD Hi-Lo #13-16 x 3/4
3	-----	Engine Kohl Model No. CV18S (Order parts from engine manufacturer)
4	532 14 97-23	Muffler Asm.
5	532 14 66-99	Pipe Exhaust LH
6	532 14 67-00	Pipe Exhaust RH
8	532 17 18-77	Bolt 5/16-18 Unc x 3/4 w/Sems
10	532 14 66-29	Shield Heat Muffler
13	532 18 60-54	Gasket Eng
14	532 14 84-56	Tube Drain Oil Easy
16	811 05 06-00	Washer Lock Ext Tooth 3/8
17	817 06 06-24	Screw 3/8-16 x 1-1/2
23	532 16 98-37	Shield Browning/Debris Guard
25	532 18 95-41	Control Choke
29	532 13 71-80	Kit Spark Arrestor
31	532 15 71-03	Tank Fuel
32	532 14 05-27	Cap Asm Fuel Top Vented N/Lang
33	532 12 34-87	Clamp Hose Black
34	532 10 60-82	Pad Spacer 1 x 1 x 1
37	532 14 21-58	Line Fuel
38	532 18 16-54	Plug Drain Oil Easy
39	532 10 92-27	Pad Idler 1.75 x .75 x .06
45	817 00 06-12	Screw 3/8-16 x .75 SMGML
101	532 16 33-05	Nut Flange M8-1.25
116	532 18 43-62	Nut Hex Flange Toplock M8-1.25

NOTE: All component dimensions given in U.S. inches
1 inch = 25.4 mm

REPAIR PARTS

TRACTOR - MODEL NO. LT2118A (96011001000), PRODUCT NO. 954 13 02-13
MOWER DECK

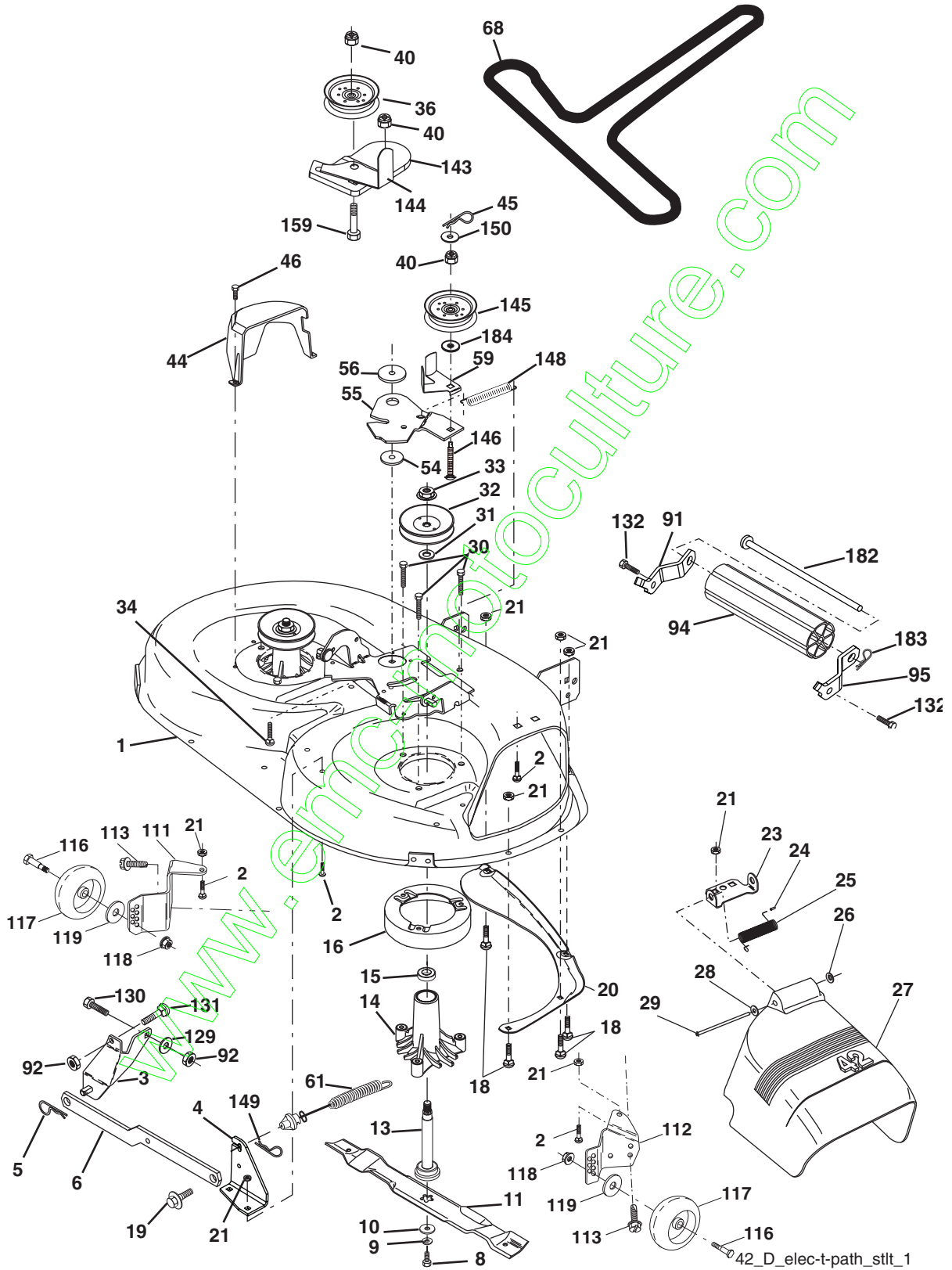

REPAIR PARTS

**TRACTOR - MODEL NO. LT2118A (96011001000), PRODUCT NO. 954 13 02-13
MOWER DECK**

KEY NO.	PART NO.	DESCRIPTION	KEY NO.	PART NO.	DESCRIPTION
1	532 16 58-92	Housing Asm Mower 42"94 T-Path	59	532 14 10-43	Guard, Belt
2	872 14 05-06	Bolt Rdhd Sqnk 5/16-18 Unc x 3/4	61	532 17 48-82	Spring Ext. Elect
3	532 13 80-17	Bracket Asm Fr Sway Bar 38/42	68	532 18 02-60	V-Belt Mower
4	532 16 54-60	Bracket Asm Deck 42"sway Bar	91	532 18 05-32	Bracket Asm Noseroller LH
5	532 12 46-70	Retainer Spring	92	873 80 06-00	Nut Lock Hex w/ins. 3/8-16 Unc
6	532 17 80-24	Bar Sway Deck	94	532 13 22-64	Roller Nose 38 & 42
8	532 85 08-57	Bolt 3/8-24 x 1 25 Gr8 Patched	95	532 18 05-33	Bracket Asm Noseroller RH
9	810 03 06-00	Washer Lock Hvy 3/8 Unplated	111	532 17 92-92	Bracket Gauge Wheel Lh
10	532 14 02-96	Washer Hard Blade Mower Vented	112	532 17 92-93	Bracket Gauge Wheel Rh
11	532 13 89-71	Blade Mower High Lift"	113	817 00 05-10	Bolt 5/16-18 Hex Whs. Hd. LCKSERR
13	532 13 76-45	Shaft Asm W/lower Bearing	116	532 12 48-42	Bolt Shoulder
14	532 12 87-74	Housing Mandrel Vented(machd)	117	532 16 57-46	Wheel Gauge
15	532 11 04-85	Bearing Ball Mandrel	118	873 93 06-00	Nut Centerlock 3/8-16 Unc
16	532 17 44-93	Stripper Mower	119	819 12 14-14	Washer 3/8 x 7/8 x 14 Ga.
18	872 14 05-05	Bolt Carr 5/16-18 x 5/8	129	819 13 13-12	Washer 13/32 x 13/16 x 12 Ga.
19	532 13 28-27	Bolt Shoulder	130	874 78 06-16	Bolt Fin Hex 3/8-16 Unc x 1 Gr. 5
20	532 15 97-70	Baffle Vortex 42	131	872 14 06-08	Bolt Rdhd Sqnk 3/8-16 Unc x1
21	873 68 05-00	Nut Crown Lock 5/16-18	132	817 00 06-12	Screw 3/8-16 x .75
23	532 17 75-63	Bracket Deflector Mower 42"	143	532 15 71-09	Bracket Arm Idler
24	532 10 53-04	Cap Sleeve 80x 112 Blk Mower	144	532 15 86-34	Keeper Belt
25	532 12 37-13	Spring Torsion Deflector 2 52	145	532 16 58-88	Pulley Idler Flat
26	532 11 04-52	Nut Push Phos & Oil	146	532 17 19-77	Bolt Carriage Idler
27	532 17 18-59	Shield Deflector	148	532 16 90-22	Spring Return Idler
28	819 11 10-16	Washer 11/32 x 5/8 x 16 Ga	149	532 16 58-98	Retainer Spring Yellow
29	532 13 14-91	Rod Hinge 42"6 75 Wlg	150	819 09 12-16	Washer 9/32 x 3/4 x 16
30	532 17 39-84	Screw Thd Rolling Hex	159	872 14 06-14	Bolt RDHD SQN 3/8-16 x 1-3/4
31	532 18 76-90	Washer Spacer	182	532 17 91-26	Rod Roller Nose Standard
32	532 15 35-35	Pulley Mandrel	183	532 16 35-52	Retainer Spring
33	532 17 83-42	Nut 9/16top Lock Flng Cntr	184	819 13 14-10	Washer 13/32 x 7/8 x 10 Ga.
34	872 11 06-12	Bolt Carr. Sh 3/8-16 x 1-1/2 Gr.5	--	532 18 19-62	Replacement Deck, Complete
36	532 13 14-94	Pulley Idler Flat 3 060	--	532 13 07-94	Mandrel Assembly (Includes Hous- ing, Shaft and Shaft Hardware Only - Pulley Not Included)
40	873 90 06-00	Nut Lock Flange 3/8-16 Unc			
44	532 14 00-88	Guard Mandrel LH Black			
45	532 12 47-88	Retainer Spring			
46	532 13 77-29	Screw Thdrol 1/4-20 x 5/8			
54	532 17 85-15	Washer Hardened			
55	532 15 50-46	Arm Idler 42"mower LT/YT			
56	532 16 57-23	Spacer Retainer Mower			

NOTE: All component dimensions given in U.S. inches
1 inch = 25.4 mm

REPAIR PARTS

TRACTOR - MODEL NO. LT2118A (96011001000), PRODUCT NO. 954 13 02-13
MOWER LIFT

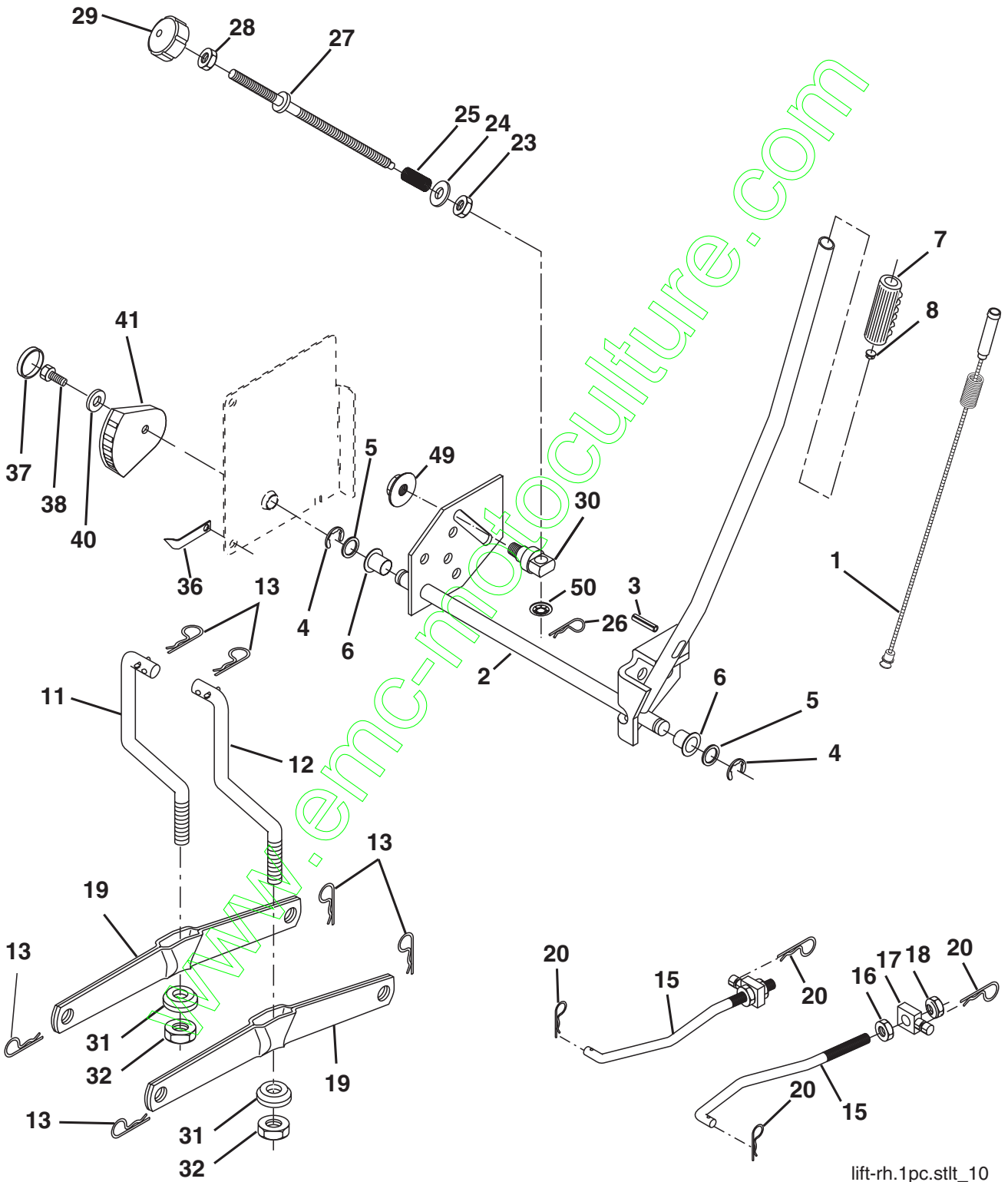

lift-rh.1pc.stlt_10

REPAIR PARTS

TRACTOR - MODEL NO. LT2118A (96011001000), PRODUCT NO. 954 13 02-13
MOWER LIFT

KEY NO.	PART NO.	DESCRIPTION
1	532 15 94-61	Wire Asm Inner/Sprg W/plunger LT
2	532 15 94-76	Shaft Asm Lift
3	532 17 89-81	Pin Groove
4	812 00 00-02	E Ring #5133-62
5	819 21 16-21	Washer 21/32 x 1 x 21 Ga.
6	532 12 01-83	Bearing Nylon Blk 629 Id
7	532 12 56-31	Grip Handle Fluted Blk
8	532 12 23-65	Button Plunger Red
11	532 13 98-65	Link Lift LH Mower
12	532 13 98-66	Link Lift RH Mower
13	532 12 46-70	Retainer Spring
15	532 17 32-88	Link Front
16	873 35 08-00	Nut Jam Hex 1/2-13 Unc
17	532 17 56-89	Trunnion Blk Zinc
18	873 80 08-00	Nut Lock W/wsh 1/2-13 Unc
19	532 13 98-68	Arm Suspension Rear
20	532 16 35-52	Retainer Spring
23	532 11 08-07	Nut Special
24	819 13 10-16	Washer 13/32 x 5/8 x 16 Ga.
25	532 16 40-24	Spring Comp Infinite
26	532 16 94-84	Retainer Clip
27	532 16 45-43	Rod Adj Lift
28	873 35 06-00	Nut Hex Jam 3/8-16 Unc
29	532 13 80-57	Knob Inf 3/8-16 Unc
30	532 15 02-33	Trunnion Inf. Height
31	532 16 98-65	Bearing Put Lift
32	873 54 06-00	Nut Crownlock 3/8-24
36	532 15 50-97	Pointer Height Ind
37	532 12 39-35	Plug Hole
38	817 06 05-16	Screw 5/16-18 x 1 SMGML Tap/R
40	819 11 24-10	Washer 11/32 x 1-1/2 x 10 Ga.
41	532 15 50-98	Ind Height STLT
49	532 14 52-12	Nut, Hex Flange Lock
50	532 11 04-52	Nut Push Phos & Oil

NOTE: All component dimensions given in U.S. inches
1 inch = 25.4 mm