

# LT2217 A

**Spare parts**  
**Ersatzteile**  
**Pièces détachées**  
**Reserve onderdelen**  
**Repuestos**  
**Reservdelar**

[www.emc-motoculture.com](http://www.emc-motoculture.com)

# ILLUSTRATED PARTS LIST

**MODEL NO. 96041003402**

**CUSTOMER CATALOG NO. LT2217A**

**PRODUCT NO. 960 41 00-34**

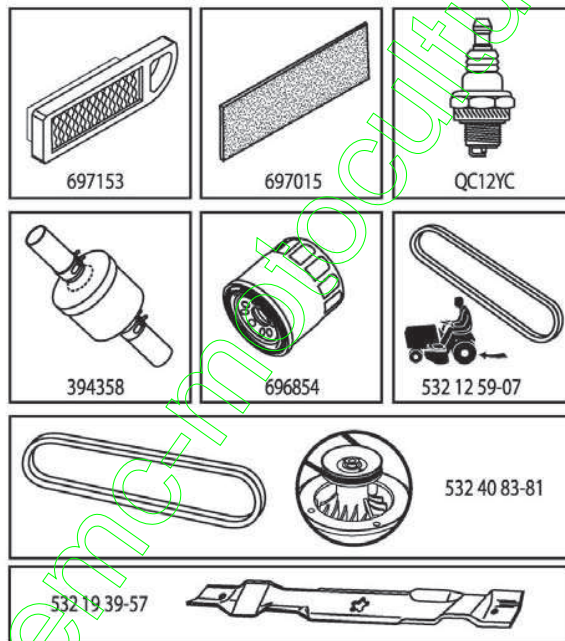

417250

**TRACTOR - - MODEL NUMBER LT2217A (96041003402), PRODUCT NO. 960 41 00-34  
DECALS**

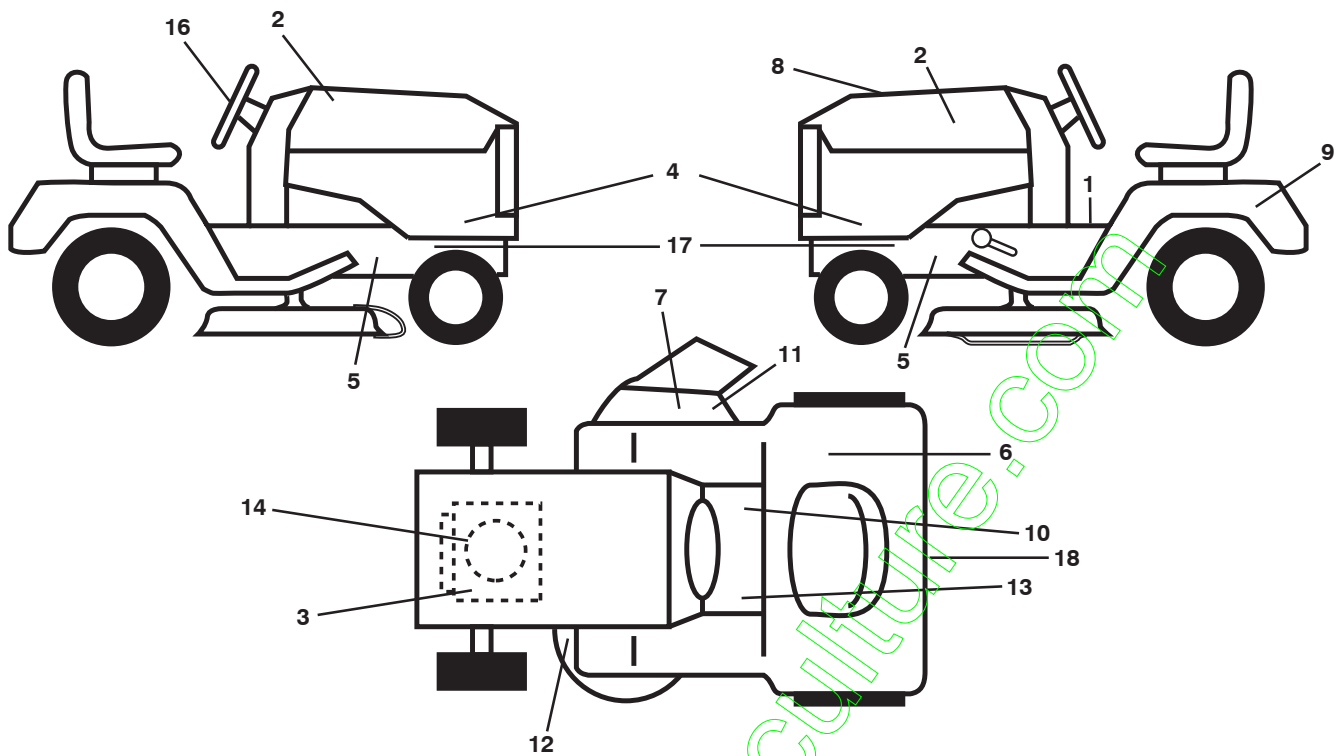

KEY NO.	PART NO.	DESCRIPTION	KEY NO.	PART NO.	DESCRIPTION
1	532 40 03-89	Decal, Operators	12	532 19 43-02	Decal, Mower V-Belt Schematic
2	532 18 95-53	Decal, Hood	13	532 15 97-37	Decal, Brake/Clutch Symbol
3	532 19 68-41	Decal, Warning Eng. Symbols	14	532 40 91-51	Decal, Eng. HP
4	532 40 86-53	Decal, Hood Panel	16	532 18 57-73	Decal, Steering
5	532 15 97-36	Decal, Chassis Hot Muffler	17	532 19 68-42	Decal
6	532 18 04-32	Decal, Fender 100 DB/CE	18	532 18 39-30	Decal, Jonsered
7	532 18 21-66	Decal, Cutfingr CE	--	532 16 69-60	Decal, Bypass
8	532 41 72-50	Decal, Rpl	--	532 16 25-98	Decal, Drawbar Load Limit
9	532 14 50-05	Decal, Battery Dngc/Poi	--	532 40 95-05	Pad, Footrest, LH
10	532 14 08-37	Decal, Saddle Brake Parking	--	532 41 12-73	Pad, Footrest, RH
11	532 19 63-57	Decal, Warning	--	532 40 86-84	Manual Oper. Euro

**WHEELS AND TIRES**

KEY NO.	PART NO.	DESCRIPTION
1	532 05 91-92	Cap Valve Tire
2	532 06 51-39	Stem Valve
3	532 13 83-36	Rim Asm 6" Front
4	532 05 99-04	Tube Front (Service Item Only)
5	532 10 62-22	Tire F T 15 x 6 0 - 6
6	532 12 49-57	Fitting Grease (Front Wheel Only)
7	532 12 49-59	Bearing Flange (Front Wheel Only)
8	532 17 50-39	Cap Axle Blk 1 50 x 1 00
9	532 10 62-68	Tire R 18 x 9.5-8 Turf Saver
--	532 42 05-31	Tire R 18 x 9.5-8 Turf Saver LT
10	532 12 49-26	Tube Rear (Service Item Only)
11	532 13 83-37	Rim Asm 8" Rear
--	532 14 43-34	Sealant, Tire (10 oz. Tube)

**NOTE:** All component dimensions given in U.S. inches  
1 inch = 25.4 mm

wheel\_art\_1-tex

# TRACTOR - - MODEL NUMBER LT2217A (96041003402), PRODUCT NO. 960 41 00-34 SCHEMATIC

SCH11

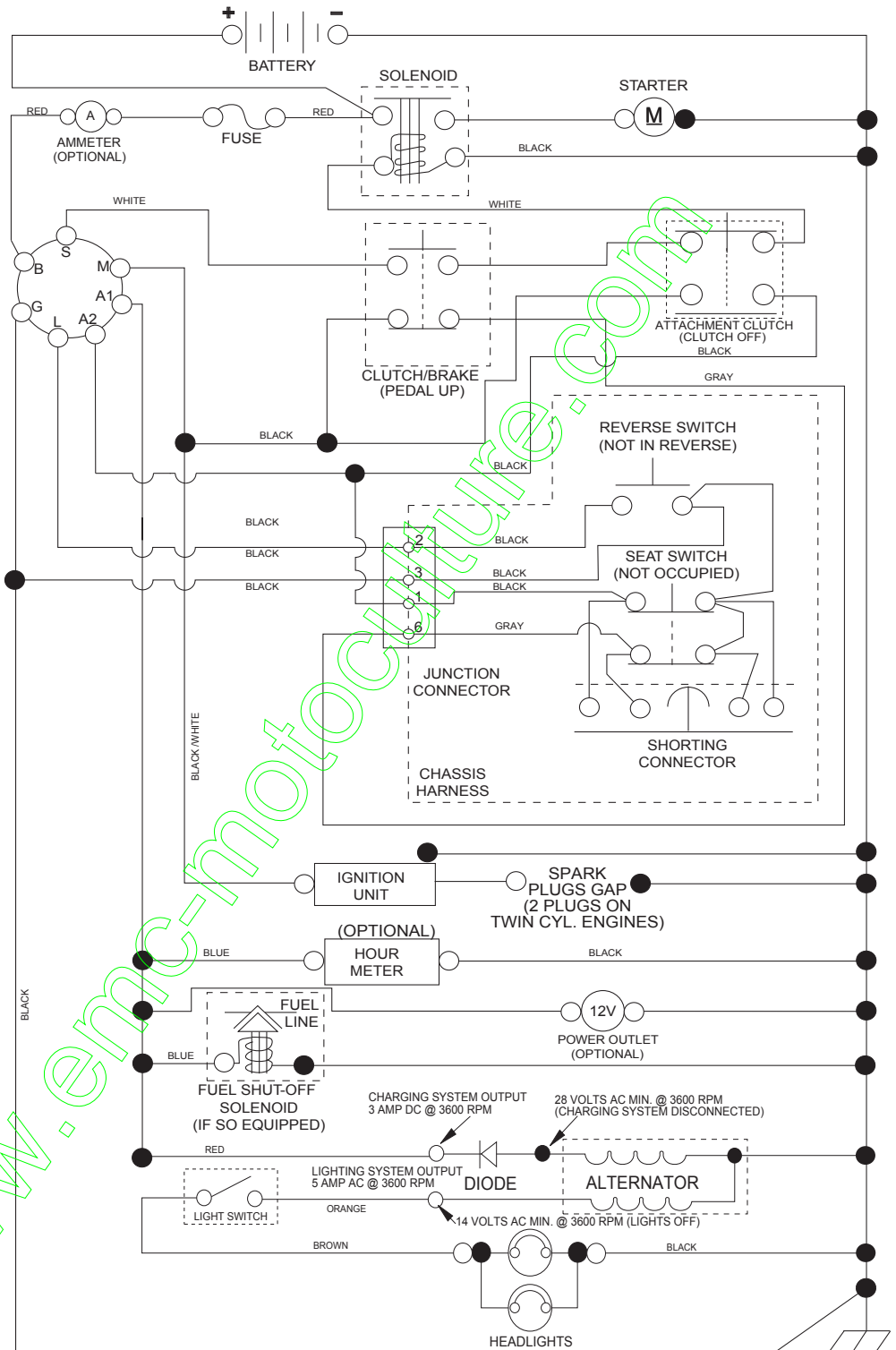

**NOTE**  
YOUR TRACTOR IS EQUIPPED WITH A SPECIAL ALTERNATOR SYSTEM. THE LIGHTS ARE NOT CONNECTED TO THE BATTERY, BUT HAVE THEIR OWN ELECTRICAL SOURCE. BECAUSE OF THIS, THE BRIGHTNESS OF THE LIGHTS WILL CHANGE WITH ENGINE SPEED. AT IDLE THE LIGHTS WILL DIM. AS THE ENGINE IS SPEEDED UP, THE LIGHTS WILL BECOME THEIR BRIGHTEST.

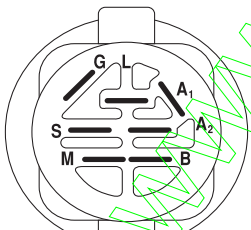

IGNITION SWITCH

POSITION	CIRCUIT	"MAKE"
OFF	M+G+A1	
RUN/OVERRIDE	B+A1	
RUN	B+A1	L+A2
START	B + S + A1	

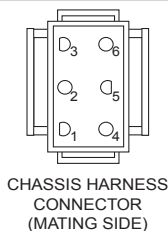

CHASSIS HARNESS CONNECTOR (MATING SIDE)

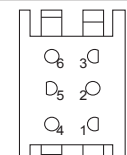

DASH HARNESS CONNECTOR (MATING SIDE)

WIRING INSULATED CLIPS  
NOTE: IF WIRING INSULATED CLIPS WERE REMOVED FOR SERVICING OF UNIT, THEY SHOULD BE RE-INSTALLED TO PROPERLY SECURE YOUR WIRING.

●  
NON-REMOVABLE CONNECTIONS

○  
REMOVABLE CONNECTIONS

**TRACTOR - - MODEL NUMBER LT2217A (96041003402), PRODUCT NO. 960 41 00-34  
ELECTRICAL**

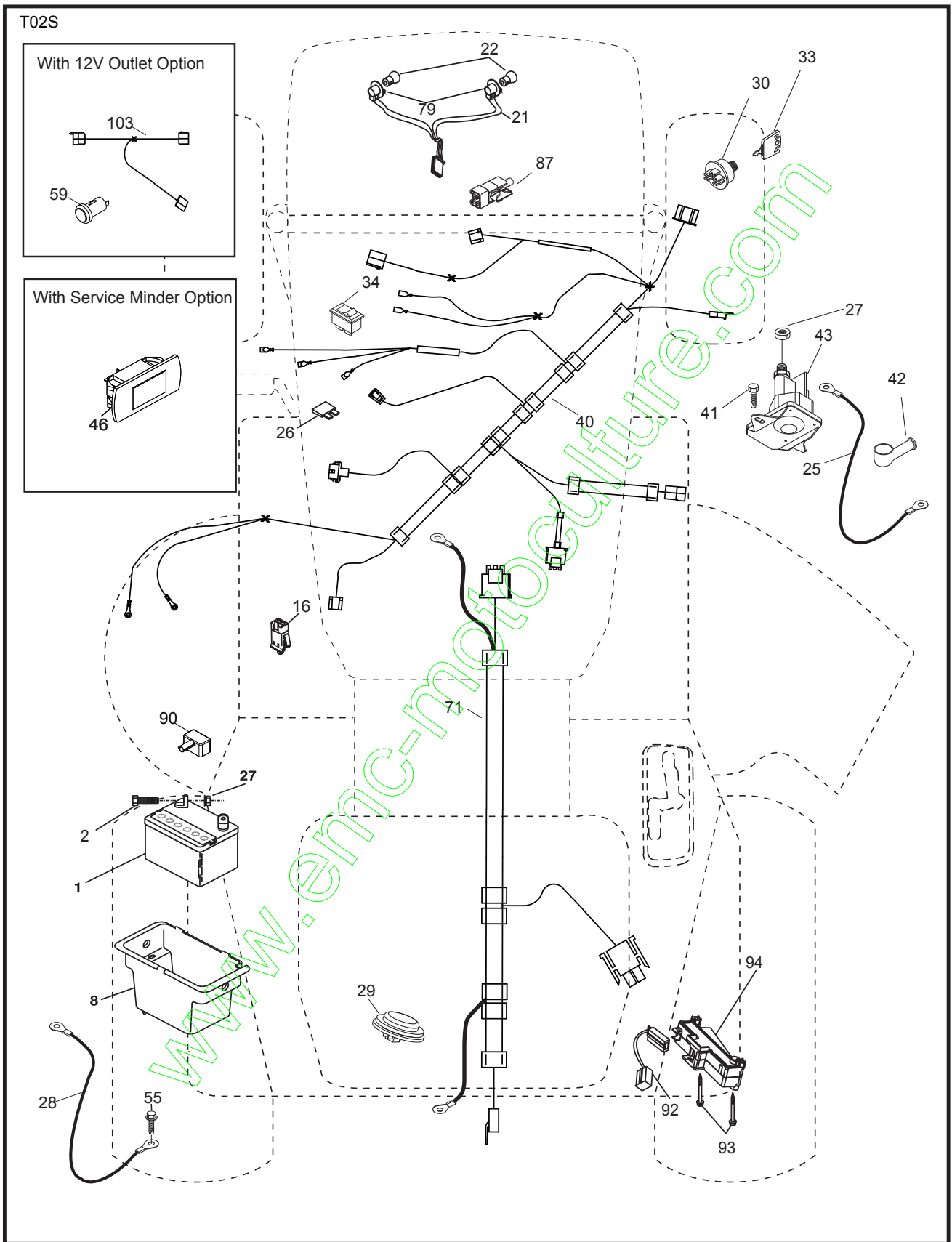

**TRACTOR - - MODEL NUMBER LT2217A (96041003402), PRODUCT NO. 960 41 00-34  
ELECTRICAL**

<b>KEY NO.</b>	<b>PART NO.</b>	<b>DESCRIPTION</b>
1	532 16 34-65	Battery
2	874 76 04-12	Bolt Hex Head 1/4-20 x 3/4
8	532 19 32-28	Box Battery
16	532 17 61-38	Switch Interlock Push-In
21	532 18 37-59	Harness Socket Light w/4152J
22	532 00 41-52	Bulb Light
25	532 40 16-62	Cable Starter
26	532 17 51-58	Fuse
27	873 51 04-00	Nut Keps Hex 1/4-20 unc
28	532 19 88-85	Cable, Ground
29	532 40 15-45	Switch, Seat
30	532 19 33-50	Switch, Ign
33	532 41 19-35	Key/Chain
34	532 11 07-12	Switch Light / Reset
40	532 40 10-98	Harness Ign. Dash
41	817 72 04-08	Screw Thd Cut 1/4-20 x 1/2
42	532 13 15-63	Cover, Terminal
43	532 19 25-07	Solenoid
55	817 06 05-12	Screw Thdrol 5/16-18 x 3/4 TYTT
71	532 40 04-49	Harness Ign.
79	532 17 52-42	Socket Asm Bulb
87	532 19 78-02	Switch Interlock
90	532 40 07-25	Cover Terminal
92	532 19 66-15	Harness Pigtail Reverse Switch
93	532 19 25-40	Screw Plastite 10-14 x 2.0
94	532 19 18-34	Module Reverse ROS

**NOTE:** All component dimensions given in U.S. inches  
1 inch = 25.4 mm

**TRACTOR - - MODEL NUMBER LT2217A (96041003402), PRODUCT NO. 960 41 00-34  
CHASSIS**

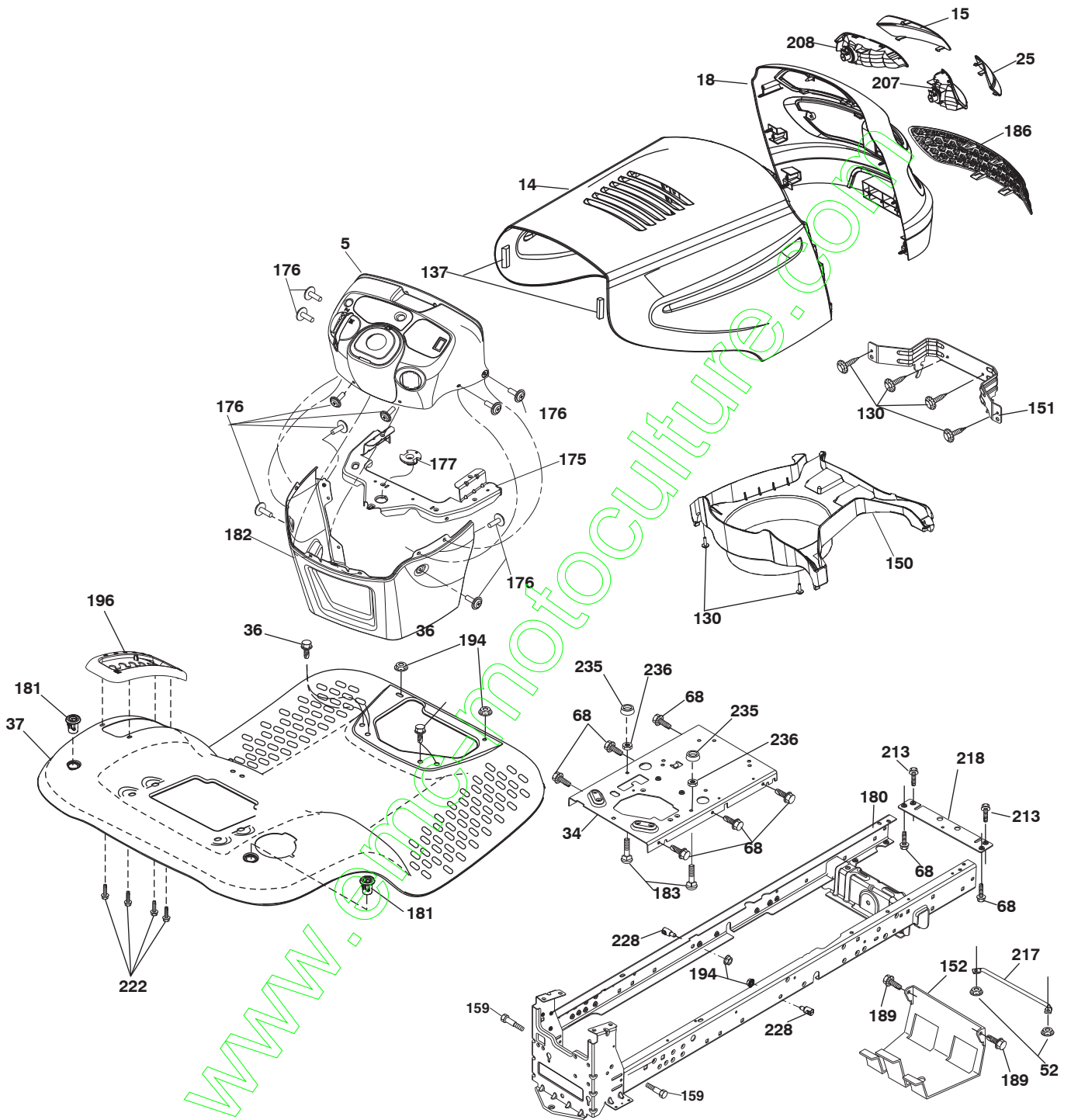

chassis-tex\_elite-sv-pro\_8\_r1

**TRACTOR - - MODEL NUMBER LT2217A (96041003402), PRODUCT NO. 960 41 00-34  
CHASSIS**

<b>KEY NO.</b>	<b>PART NO.</b>	<b>DESCRIPTION</b>
5	532 41 12-79	Dash
14	532 19 47-57	Hood
15	532 18 97-54	Lens LH
18	532 19 29-15	Grille/Lens Asm.
25	532 18 97-55	Lens RH
34	532 19 61-25	Plate Engine
36	817 06 05-12	Screw 5/16-18 x 3/4
37	532 41 12-83	Fender
52	873 68 05-00	Nut Crown Lock 5/16
68	817 49 05-08	Screw THDROL 5/16-18 x 1/2
130	532 19 16-11	Screw 10 x 3/4 Single Lead Hex
137	532 18 49-21	Bumper Dash
150	532 18 43-22	Air Duct
151	532 40 78-07	Bracket Pivot
152	532 19 95-35	Shield Browning
159	817 00 06-12	Screw 3/8-16 x 3/4
175	532 19 32-43	Crossmember
176	532 40 07-76	Screw 10-24 x 5/8
177	532 19 52-28	Bushing Steering
180	532 19 54-57	Chassis
181	532 40 47-96	Bushing Mtg. Fender Crgo
182	532 19 30-57	Dash Lower
183	874 78 05-20	Bolt 5/16-18 unc x 1-1/4
186	532 18 97-53	Insert Grille
189	817 00 05-12	Screw 5/16-18 x 3/4
194	873 90 05-00	Nut Lock Hex Flange 5/16-18
196	532 40 97-28	Console Asm. Deck Lift
207	532 18 38-33	Bezel RH
208	532 18 38-32	Bezel LH
213	874 76 05-12	Bolt 5/16-18 x 3/4
217	532 40 91-67	Rod Pivot Hood
218	532 19 63-95	X-Piece Hood Stop
222	532 13 77-29	Screw 1/4-20 x 5/8
228	532 19 51-61	Stud Fastener
235	532 40 61-29	Spacer Fender
236	873 93 05-00	Nut Lock 5/16-18 unc

**NOTE:** All component dimensions given in U.S. inches  
1 inch = 25.4 mm



TRACTOR - - MODEL NUMBER LT2217A (96041003402), PRODUCT NO. 960 41 00-34  
DRIVE

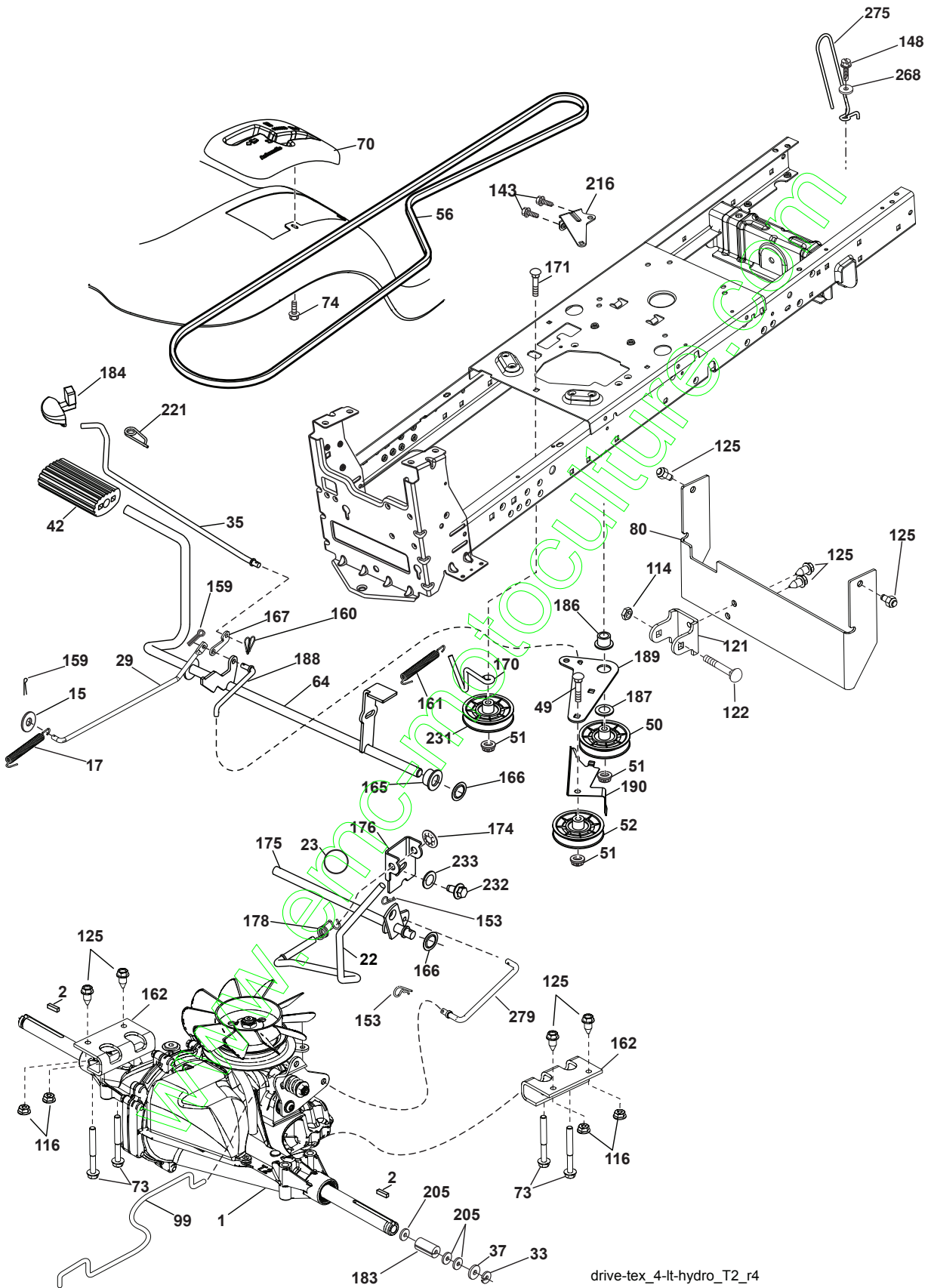

drive-tex\_4-lt-hydro\_T2\_r4

**TRACTOR - - MODEL NUMBER LT2217A (96041003402), PRODUCT NO. 960 41 00-34 DRIVE**

KEY NO.	PART NO.	DESCRIPTION	KEY NO.	PART NO.	DESCRIPTION
1	-----	Transaxle, Hydro GR T2 (Internal parts not available)	160	532 16 94-84	Retainer Clip
2	532 12 35-83	Key	161	532 10 57-09	Spring, Return, Clutch
15	819 13 13-16	Washer 13/32 x 13/16 x 16 Ga.	162	532 40 87-84	Adapter Transaxle
17	532 19 72-96	Spring, Brake	165	532 19 62-12	Bushing Brake Shaft
22	532 19 76-60	Rod Shift	166	532 19 72-90	Nut Push
23	532 12 12-74	Knob	167	532 40 52-57	Latch Brake Parking
29	532 40 83-91	Rod, Brake	170	532 41 34-30	Keeper Belt Centerspan
33	812 00 00-01	Ring E	171	872 11 06-22	Bolt RDHD SQNK 3/8-16 unc x 2
35	532 19 77-22	Rod, Brake, Park	174	532 19 72-89	Nut Push
37	532 12 17-49	Washer 25/32 x 1-1/4 x 16 Ga.	175	532 40 85-39	Shaft Asm Shift
42	532 12 48-72	Cover, Foot Pedal	176	532 19 62-14	Arm Clevis Rod Shift
49	872 11 06-14	Bolt	178	532 19 74-56	Spring Shift
50	532 19 43-27	Pulley Idler Flat	183	532 15 69-72	Spacer Axle
51	873 90 06-00	Lock Nut 3/8-16	184	532 41 12-89	Handle Parking Brake
52	532 19 43-26	Idler V-Groove 910" Offset	185	872 11 06-20	Bolt Rdhd Sqnk 3/8-16 x 2-1/2
56	532 12 59-07	V-Belt, Drive	186	532 19 43-21	Spacer Retainer
64	532 19 62-00	Shaft Asm. Pedal Brake Control	187	819 13 32-10	Washer
70	532 41 13-29	Console Shift	188	532 19 43-23	Link Clutch Ground Drive
73	874 49 05-44	Bolt Hex Flghd 5/16-18 Gr. 5	189	532 19 43-17	Bellcrank Ground Drive
74	532 14 24-32	Screw Hex Wsh Hi-Lo 1/4 x 1/2 unc	190	532 19 43-18	Keeper Bellcrank Ground Drive
80	532 40 83-93	Strap Torque	205	532 12 17-48	Washer
99	532 40 84-18	Rod Bypass	216	532 19 61-31	Bracket Pulley Idler
114	873 80 05-00	Nut Lock 16-18 unc	221	532 40 31-87	Retainer Spring Clip Handle
116	873 90 05-00	Nut Lock Hex Flange 5/16-18	231	532 40 72-87	Idler V-Groove
121	532 17 56-11	Bracket Mount Torque	232	874 78 07-16	Bolt 7/16-14 x 1 Gr. 5
122	872 01 05-20	Bolt 5/16-18 x 2.50	233	532 40 52-96	Washer Serrated
125	817 00 05-12	Screw 5/16-18 x 3/4	268	819 13 16-14	Washer 13/32 x 1 x 14 Ga.
143	817 49 05-08	Screw Thdrol 5/16-18 x 1/2	275	532 18 24-02	Guard Muffler
148	817 00 06-12	Screw 3/8-16 x 3/4	279	532 40 85-38	Link Shift
153	532 12 47-88	Retainer Spring			
159	876 02 04-12	Pin Cotter 1/8 x 3/4			

**NOTE:** All component dimensions given in U.S. inches  
1 inch = 25.4 mm

www.emc-motors.com

**TRACTOR - - MODEL NUMBER LT2217A (96041003402), PRODUCT NO. 960 41 00-34  
ENGINE**

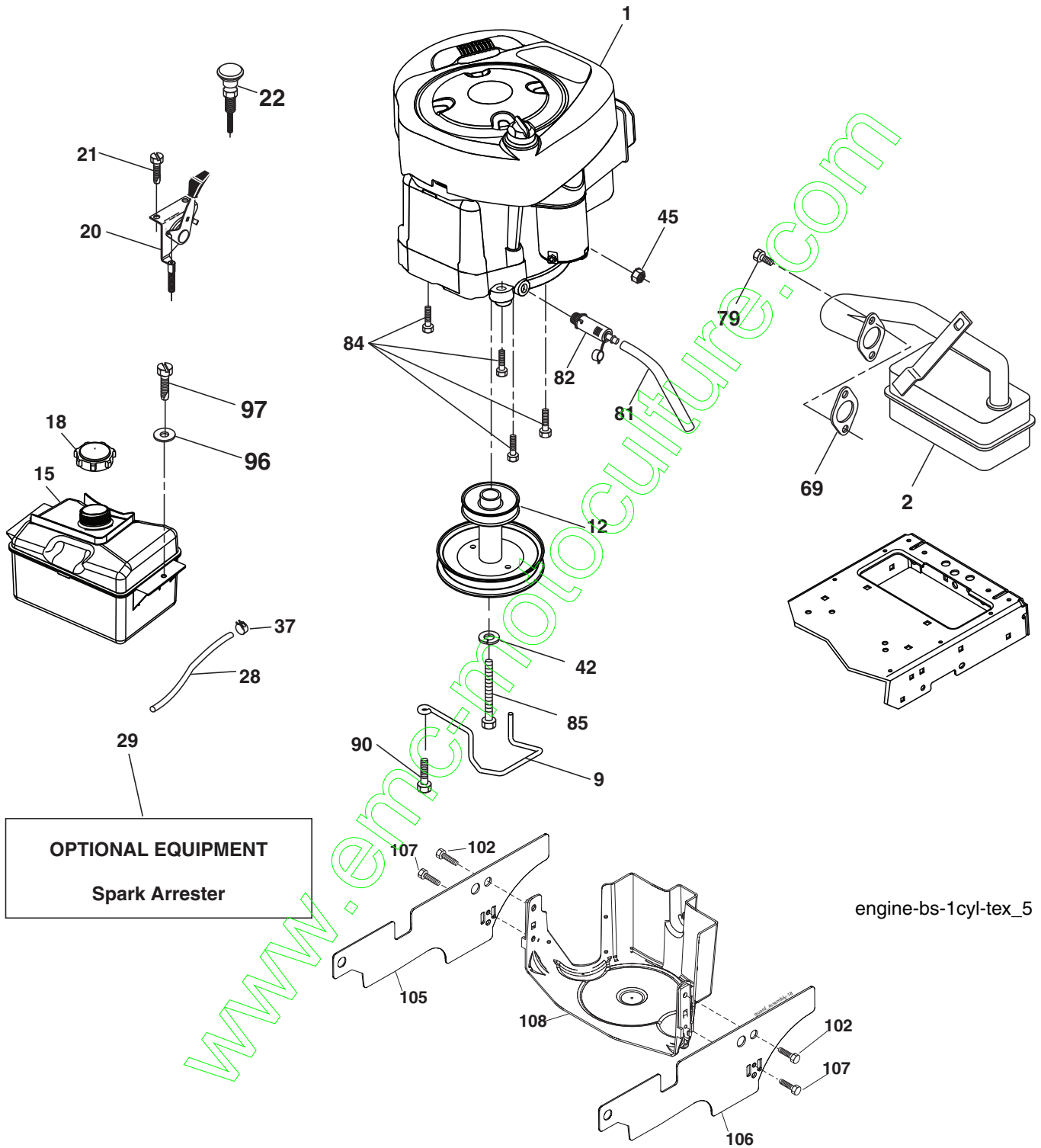

**TRACTOR - - MODEL NUMBER LT2217A (96041003402), PRODUCT NO. 960 41 00-34  
ENGINE**

KEY NO.	PART NO.	DESCRIPTION
1	-----	Engine Briggs Model No. 31E777
2	532 13 73-52	Muffler
9	532 19 43-19	Keeper Belt Engine
12	532 40 19-85	Pulley Engine
15	532 40 75-45	Tank Fuel
18	532 19 77-25	Cap Asm
20	532 18 38-97	Control Throttle
21	532 19 16-11	Screw 10 x 3/4 Single Lead-Hex
22	532 19 49-81	Control Choke
28	532 13 70-40	Fuel Line
29	532 13 71-80	Spark Arrester Kit
37	532 12 34-87	Clamp Hose
42	810 04 07-00	Bolt 5/16-18 unc x 3/4 w/Sems
45	873 51 04-00	Nut Keps Hex 1/4-20 unc
69	532 16 52-91	Gasket
79	532 19 23-34	Screw 5/16-18 x .75
81	532 14 84-56	Tube Drain Oil Easy
82	532 18 16-54	Plug Drain Oil
84	817 06 06-20	Screw 3/8-16 x 1-1/4
85	532 17 39-37	Bolt Hex 7/16-20 x 4 Gr. 5
90	817 00 06-16	Screw 3/8-16 x 1
96	819 09 14-16	Washer 9/32 x 7/8 x 16 Ga.
97	817 67 04-12	Screw 1/4-20 x 3/4
102	817 00 05-12	Screw 5/16-18 x 3/4
105	532 41 05-28	Shield Side LH
106	532 41 05-29	Shield Side RH
107	532 13 77-29	Screw 1/4-20 x 5/8
108	532 41 05-32	Cover Asm Engine

**NOTE:** All component dimensions given in U.S. inches  
1 inch = 25.4 mm

**Engine Power Rating Information**

The gross power rating for individual gas engine models is labeled in accordance with SAE (Society of Automotive Engineers) code J11940 (Small Engine Power & Torque Rating Procedure), and rating performance has been obtained and corrected in accordance with SAE J1995 (Revision 2002-5). Actual gross engine power will be lower and is affected by, among other things, ambient operating conditions and engine-to-engine variability. Given both the wide array of products on which engines are placed and the variety of environmental issues applicable to operating the equipment, the gas engine will not develop the rated gross power when used in a given piece of power equipment (actual "on-site" or net horsepower). This difference is due to a variety of factors including, but not limited to, accessories (air cleaner, exhaust, charging, cooling, carburetor, fuel pump, etc.), application limitations, ambient operating conditions (temperature, humidity, altitude), and engine-to-engine variability. Due to manufacturing and capacity limitations, Briggs & Stratton may substitute an engine of higher rated power for this Series engine.

TRACTOR - - MODEL NUMBER LT2217A (96041003402), PRODUCT NO. 960 41 00-34  
MOWER DECK

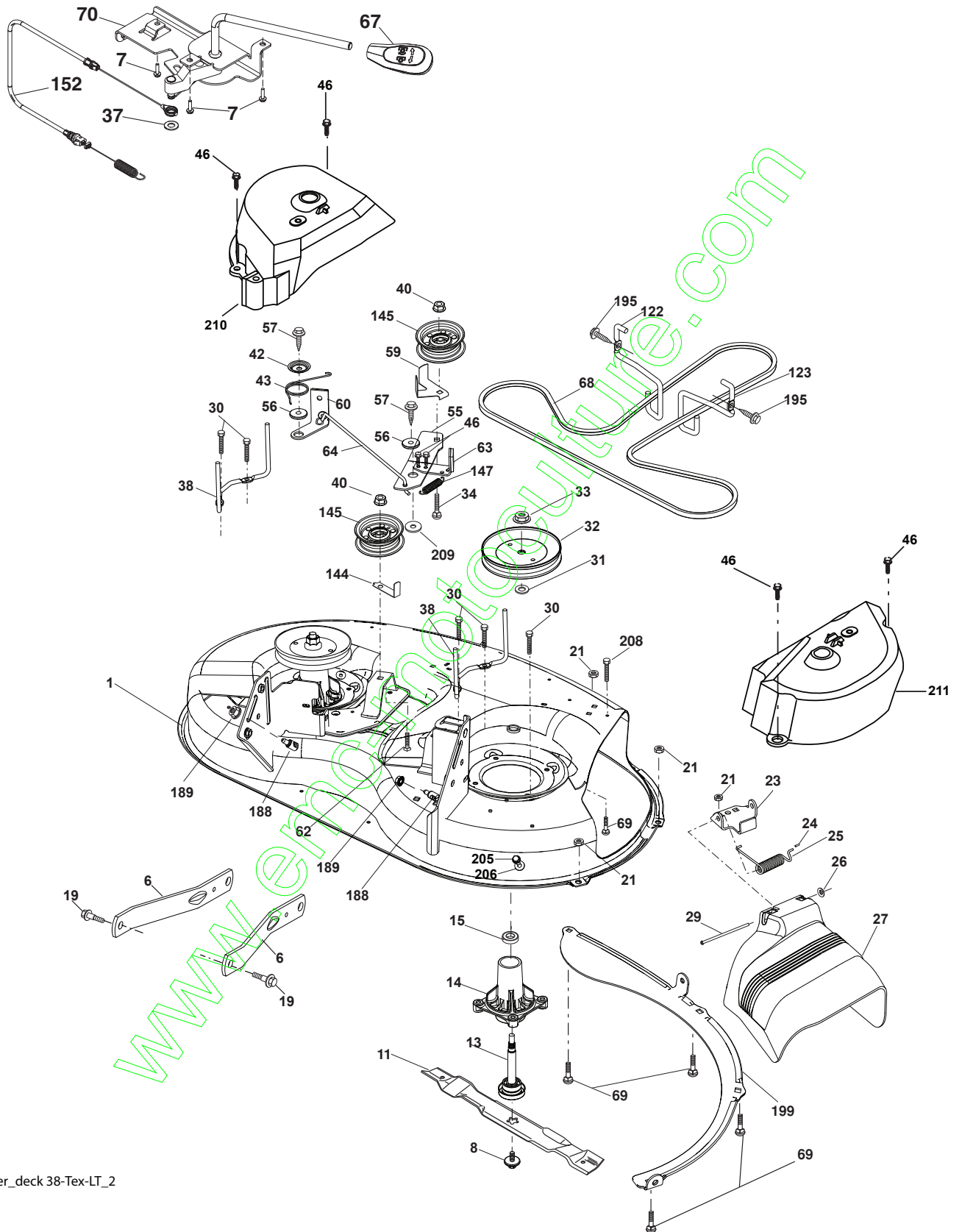

mower\_deck 38-Tex-LT\_2

**TRACTOR - - MODEL NUMBER LT2217A (96041003402), PRODUCT NO. 960 41 00-34  
MOWER DECK**

KEY NO.	PART NO.	DESCRIPTION	KEY NO.	PART NO.	DESCRIPTION
1	532 19 42-51	Mower Housing	63	532 19 94-70	Arm Brake Mower
6	532 19 51-86	Arm Suspension	64	532 19 97-90	Link Brake
7	532 19 16-11	Screw 10 x 3/4 Single Lead Hex	67	532 40 30-12	Handle Clutch Cable
8	532 19 30-03	Bolt/Washer asm 7/16-20 unf	68	532 40 83-81	V-Belt
11	532 19 39-57	Blade, Premium	69	872 14 05-05	Bolt
13	532 19 28-72	Shaft, Asm	70	532 19 83-32	Clutch Asm Manual
14	532 18 72-81	Housing, Mandrel	122	532 19 72-58	Keeper Belt Engine LH
15	532 11 04-85	Bearing, Ball, Mandrel	123	532 19 72-59	Keeper Belt Engine RH
19	532 19 65-39	Bolt, Shoulder	144	532 19 34-14	Keeper Belt
21	873 68 05-00	Nut, Crownlock 5/16-18 unc	145	532 19 31-97	Pulley, Idler, Flat
23	532 19 25-57	Bracket, Deflector	147	532 40 18-72	Spring Return
24	532 10 53-04	Cap, Sleeve	152	532 40 87-14	Manual Clutch Cable
25	532 19 70-26	Spring, Torsion, Deflector	188	532 19 51-61	Stud Fastener
26	532 11 04-52	Nut, Push	189	873 90 05-00	Nut Lock Hex Flange
27	532 40 16-18	Shield, Deflector	195	817 00 06-12	Screw 3/8-16 x 3/4
29	532 13 14-91	Rod, Hinge	199	532 40 00-95	Baffle Vortex
30	532 17 39-84	Screw Thdrol Rolling Wsh Hd	205	817 49 04-16	Screw 1/4-20 x 1.00
31	532 18 76-90	Washer, Spacer	206	819 09 14-16	Washer 9/32 x 7/8 x 16
32	532 19 97-89	Pulley, Mandrel	208	817 67 06-08	Screw Thrdol 3/8-16 x 1/2
33	532 40 02-34	Nut, Toplock, Flanged	209	819 13 32-10	Washer 13/32 x 2 x 10
37	819 13 13-16	Washer	210	532 40 92-56	Cover Mandrel LH
38	532 19 95-41	Keeper Belt LH Mandrel	211	532 40 92-57	Cover Mandrel RH
40	873 90 06-00	Nut, Lock Flg. 3/8-16 unc	-	532 19 28-70	Mandrel Assembly (Includes housing, shaft assembly, and bearing only - pulley/nut/washer and blade bolt/washers not included)
42	532 19 84-10	Spring Torsion Brake	-	532 40 86-77	Replacement Mower, Complete
43	532 19 72-56	Spring Torsion Retainer			
46	532 13 77-29	Screw 1/4-20 x 5/8			
55	532 19 72-49	Arm, Idler			
56	532 19 90-92	Spacer, Retainer			
57	817 00 06-16	Screw 3/8-16 x 1			
59	532 14 10-43	Guard, Tuv Idler			
60	532 19 94-71	Arm Brake Mower			
62	872 11 06-12	Bolt Carr. 3/8-16 x 1-1/2			

**NOTE:** All component dimensions given in U.S. inches  
1 inch = 25.4 mm

**TRACTOR - - MODEL NUMBER LT2217A (96041003402), PRODUCT NO. 960 41 00-34  
STEERING ASSEMBLY**

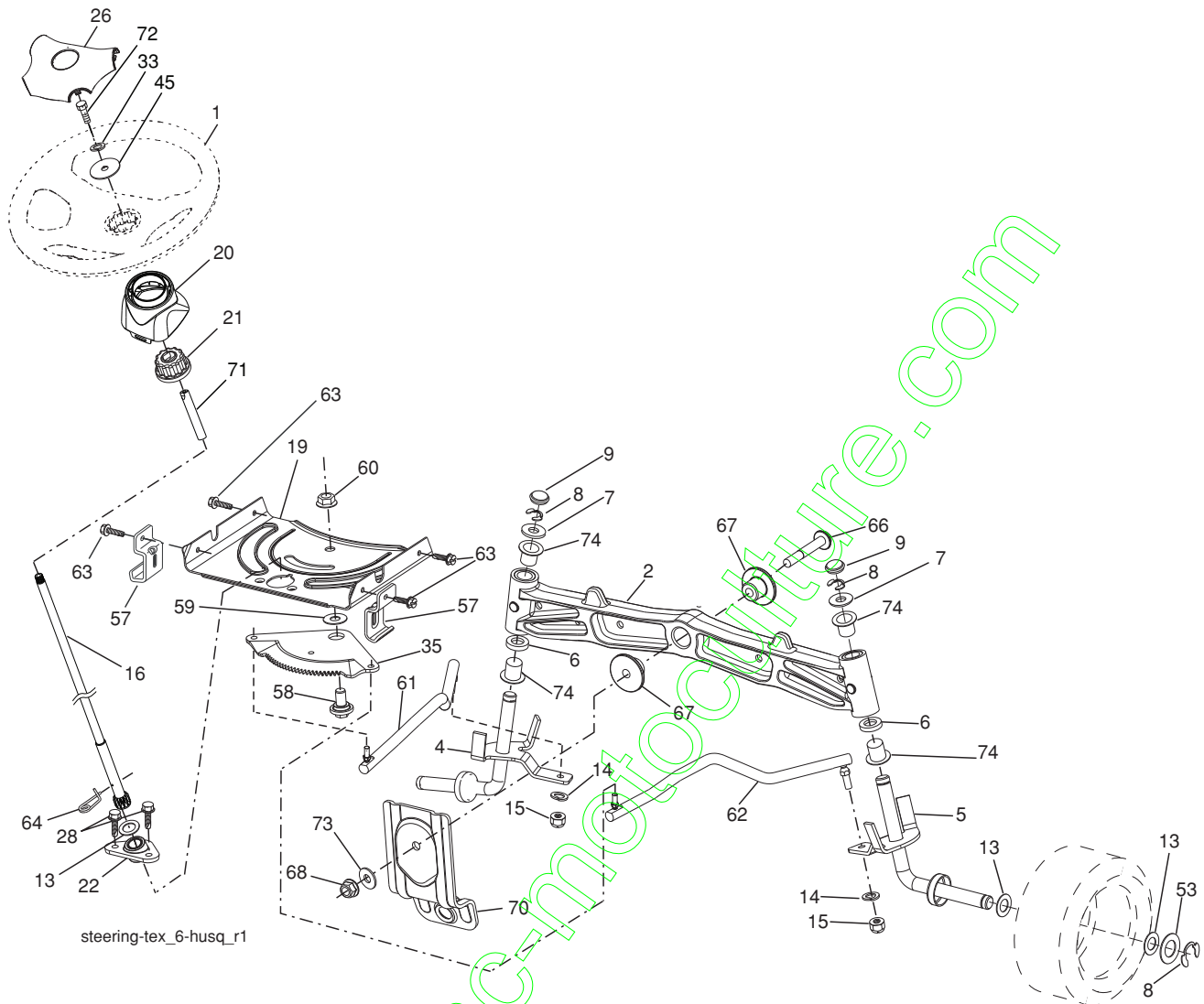

steering-tex\_6-husq\_r1

KEY NO.	PART NO.	DESCRIPTION	KEY NO.	PART NO.	DESCRIPTION
1	532 19 46-37	Wheel, Steering	53	532 18 89-67	Washer Hardened .793 x 1.637 x .060
2	532 19 56-73	Axle Asm., Front	57	532 40 74-65	Bracket Upstop
4	532 40 30-87	Spindle Asm., LH	58	532 19 47-47	Bolt Shoulder Sector Pivot CFM
5	532 40 30-88	Spindle Asm., RH	59	532 19 47-48	Washer Thrust Sector Steering
6	532 12 49-31	Bearing, Race Thrust Hardened	60	873 97 10-00	Nut Flange Lock 5/8-11
7	532 12 17-48	Washer 25/32 x 1-5/8 x 16 Ga.	61	532 19 47-40	Draglink, LH
8	812 00 00-29	Ring, Clip #T5304-75	62	532 19 47-41	Draglink, RH
9	532 12 12-32	Cap, Spindle	63	817 00 05-12	Screw 5/16-18 x 3/4
13	532 12 17-49	Washer 25/32 x 1-1/4 x 16 Ga.	64	532 19 98-49	Retainer Clip Spring Steering
14	810 04 06-00	Washer, Lock Hvy Hlcl Spr 3/8	66	871 02 07-48	Bolt Hex Fghd 7/16-14 x 3 Serr
15	873 54 06-00	Nut, Crown Lock 3/8-24 unf	67	532 19 47-37	Bushing PM Front Axle
16	532 19 60-74	Shaft Steering	68	873 90 07-00	Nut Lock Flange 7/16-14 Gr. 5
19	532 19 47-29	Plate Steering	70	532 19 61-97	Bracket Deck Susp. Front
20	532 41 12-91	Boot, Steering	71	532 19 60-75	Shaft Extension Steering
21	532 18 67-37	Adapter, Wheel Steering	72	874 78 05-72	Bolt 5/16-18 unc x 4.5. Gr. 5
22	532 19 48-45	Bushing, Strg. Blk	73	532 19 91-62	Washer 1.5 x .505 x .118
26	532 19 46-03	Insert, Wheel Steering	74	532 12 49-37	Bearing
28	817 00 06-12	Screw 3/8-16 x 3/4			
33	810 04 05-00	Washer Lock 5/16			
35	532 19 47-32	Gear, Sector Plate			
45	819 11 38-12	Washer 11/32 x 3/8 x 12 Ga.			

**NOTE:** All component dimensions given in U.S. inches  
1 inch = 25.4 mm

**TRACTOR - - MODEL NUMBER LT2217A (96041003402), PRODUCT NO. 960 41 00-34  
SEAT ASSEMBLY**

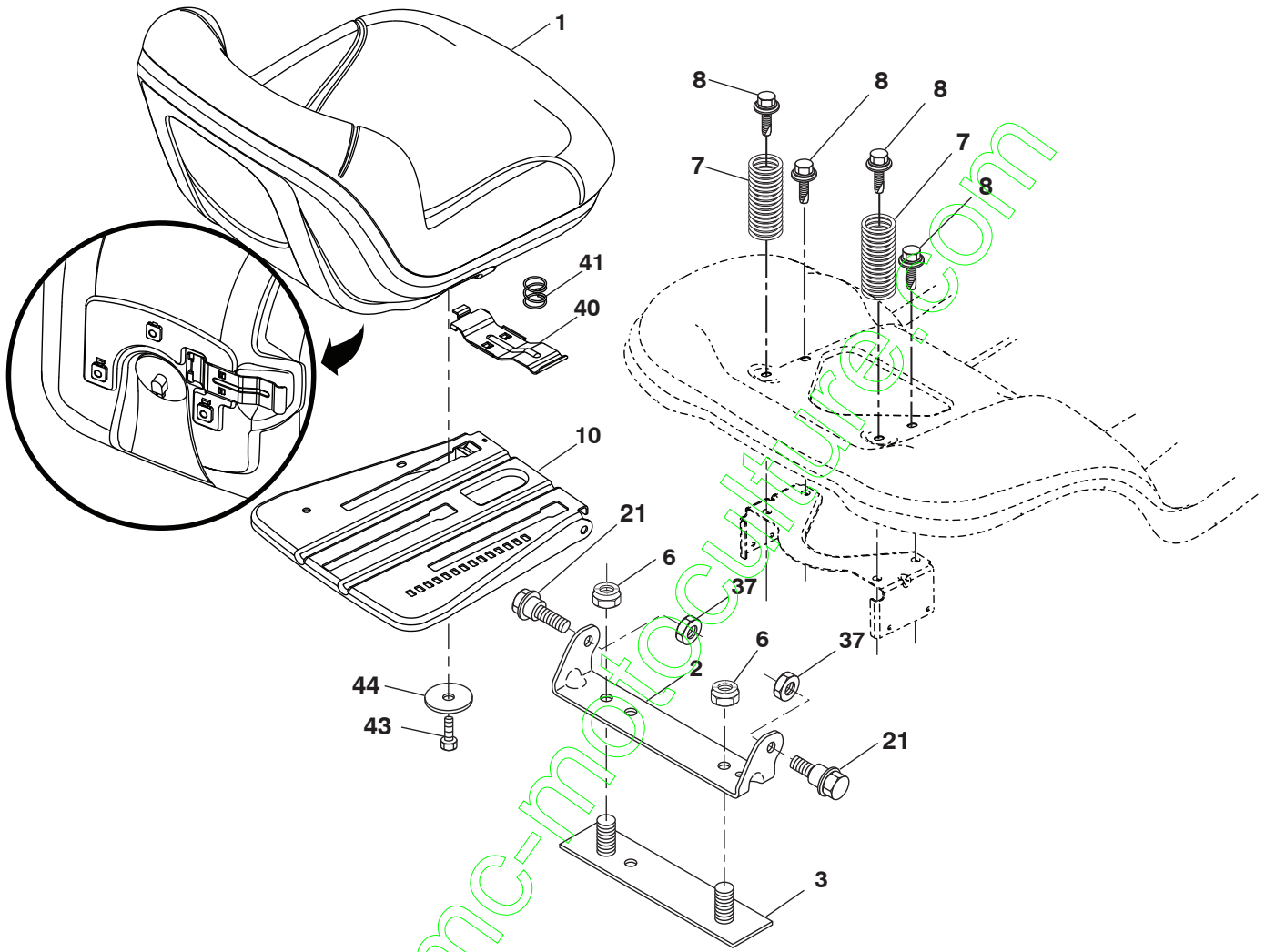

seat-tex\_7A-vgt

KEY NO.	PART NO.	DESCRIPTION
1	532 41 14-05	Seat
2	532 18 01-66	Bracket Pivot Fender
3	532 14 06-75	Strap, Asm Fender
6	873 80 06-00	Nut, Lock w/Ins. 3/8-16 unc
7	532 12 41-81	Spring, Seat Cprsn
8	532 17 18-77	Bolt 5/16-18 unc x 3/4 w/Sems
10	532 19 69-77	Pan, Seat
21	532 17 18-52	Bolt, Shoulder 5/16-18

KEY NO.	PART NO.	DESCRIPTION
37	873 80 05-00	Nut, Lock 5/16-18 unc
40	532 19 76-61	Handle Slide
41	532 19 82-00	Spring Latch
43	874 76 06-12	Bolt 3/8-16 unc x 3/4
44	819 13 38-12	Washer 13/32 x 2-3/8 x 12

**NOTE:** All component dimensions given in U.S. inches  
1 inch = 25.4 mm



**TRACTOR - - MODEL NUMBER LT2217A (96041003402), PRODUCT NO. 960 41 00-34  
MOWER LIFT**

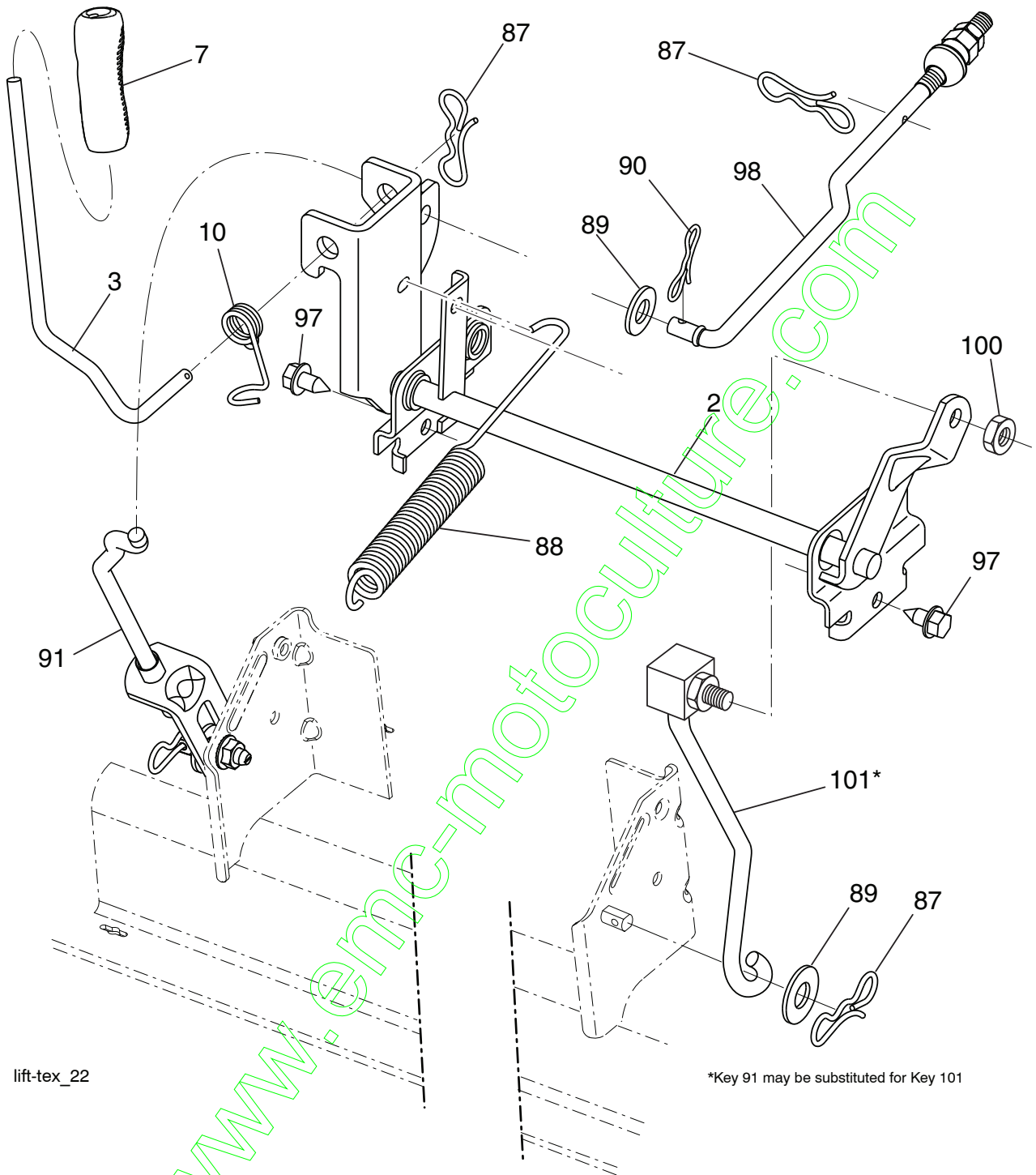

lift-tex\_22

\*Key 91 may be substituted for Key 101

KEY NO.	PART NO.	DESCRIPTION
2	532 19 52-23	Shaft Asm., Lift
3	532 19 52-31	Lever Asm., Lift RH
7	532 41 15-55	Grip, Lever
10	532 19 63-14	Spring Torsion
87	532 19 42-09	Pin Cotter 7/16 Bow Tie Lock
88	<b>532 41 07-10</b>	Spring Lift Assist
89	819 19 19-12	Washer Clear Zinc
90	532 19 42-08	Pin Cotter 5/16 Bow Tie Lock

KEY NO.	PART NO.	DESCRIPTION
91	532 19 51-81	Link Lift Susp Mower Rear
97	817 00 06-12	Screw 3/8-16 x .75 Smgml Tap/R.Z
98	532 19 52-70	Link Lift Susp Front Mower
100	873 93 06-00	Nut Centerlock 3/8-16
101	<b>532 40 70-03</b>	Link Lift Susp FXD

**NOTE:** All component dimensions given in U.S. inches  
1 inch = 25.4 mm