

# LT2217A

Spare parts

Ersatzteile

Pièces détachées

Reserve onderdelen

Repuestos

Reservdelar

[www.emc-motoculture.com](http://www.emc-motoculture.com)

# ILLUSTRATED PARTS LIST

**MODEL NO. 96041004300**

**CUSTOMER CATALOG NO. LT2217A**

**PRODUCT NO. 960 41 00-43**

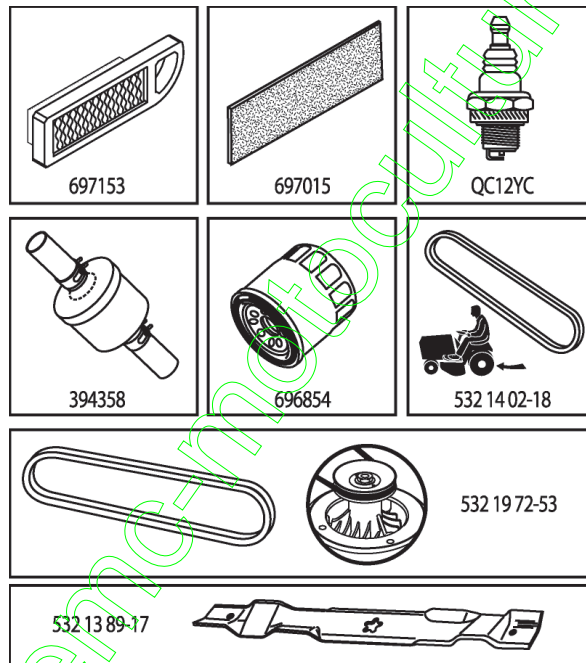

408628

**TRACTOR -- MODEL NUMBER LT2217A (96041004300), PRODUCT NO. 960 41 00-43  
DECALS**

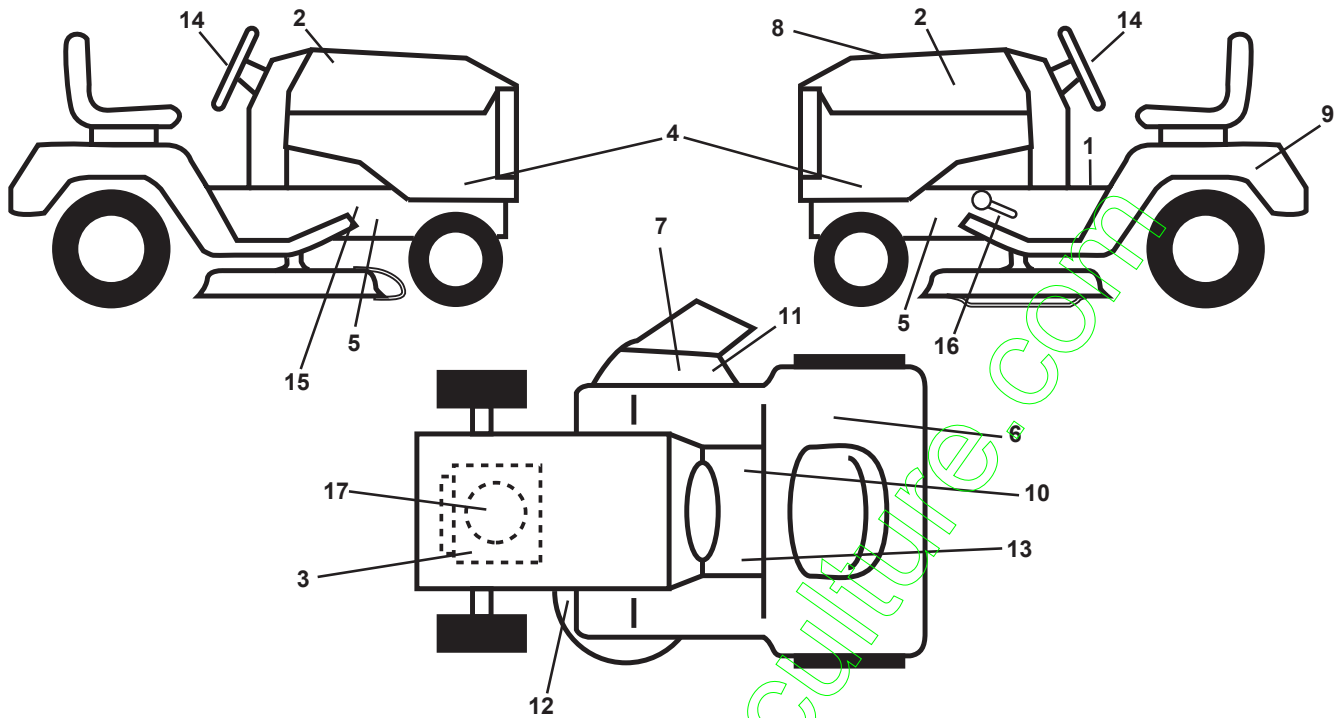

KEY NO.	PART NO.	DESCRIPTION	KEY NO.	PART NO.	DESCRIPTION
1	532 40 03-89	Decal, Operators	14	532 18 57-73	Decal, Wheel Strg.
2	532 18 95-53	Decal, Hood	15	532 18 39-30	Decal, Cover/Belt
3	532 19 68-41	Decal, Warning Eng. Symbols	16	532 40 86-54	Decal, Fender
4	532 40 86-53	Decal, Hood Panel	17	532 40 91-51	Decal, BS
5	532 15 97-36	Decal, Chassis Hot Muffler	--	532 40 95-05	Pad, Footrest, LH
6	532 18 04-32	Decal, Fender 100 DB/CE	--	532 41 12-73	Pad, Footrest, RH
7	532 18 21-66	Decal, Cutfinger CE	--	532 16 25-98	Decal, Drawbar Load Limit
8	532 40 86-28	Decal, Rpl Kohl	--	532 16 69-60	Decal, Bypass
9	532 14 50-05	Decal, Battery Dnge/Poi	--	532 41 73-98	Manual Oper. Euro
10	532 14 08-37	Decal, Saddle Brake Parking	--	532 40 92-10	Manual Oper. Scand
11	532 19 63-57	Decal, Warning	--	532 40 92-11	Manual Oper. E-Bloc
12	532 16 03-96	Decal, Mower V-Belt Schematic	--	532 40 92-12	Manual Oper. Baltic
13	532 15 97-37	Decal, Brake/Clutch Symbol			

**WHEELS AND TIRES**

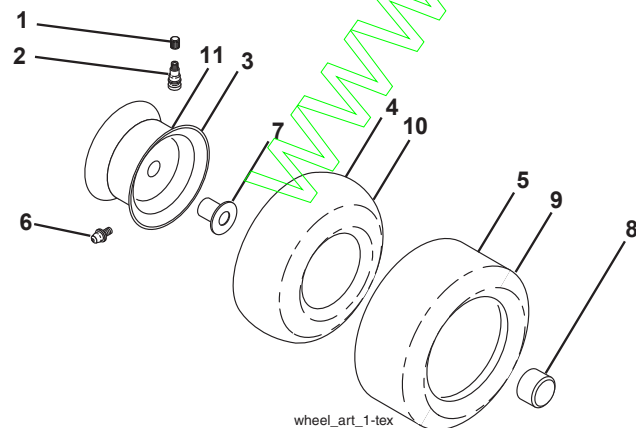

KEY NO.	PART NO.	DESCRIPTION
1	532 05 91-92	Cap Valve Tire
2	532 06 51-39	Stem Valve
3	532 13 83-36	Rim Asm 6" Front Service
4	532 05 99-04	Tube Front (Service Item Only)
5	532 10 62-22	Tire F T 15 x 6 0 - 6 Service
6	532 12 49-57	Fitting Grease (Front Wheel Only)
7	532 12 49-59	Bearing Flange (Front Wheel Only)
8	532 17 50-39	Cap Axle Blk 1 50 x 1 00
9	532 10 62-68	Tire R TS 18 x 9.5-8 C Service
10	532 12 49-26	Tube Rear (Service Item Only)
11	532 13 83-37	Rim Asm 8" Rear Service
--	532 14 43-34	Sealant, Tire (10 oz. Tube)

**NOTE:** All component dimensions given in U.S. inches  
1 inch = 25.4 mm

# TRACTOR - - MODEL NUMBER LT2217A (96041004300), PRODUCT NO. 960 41 00-43 SCHEMATIC

SCH11

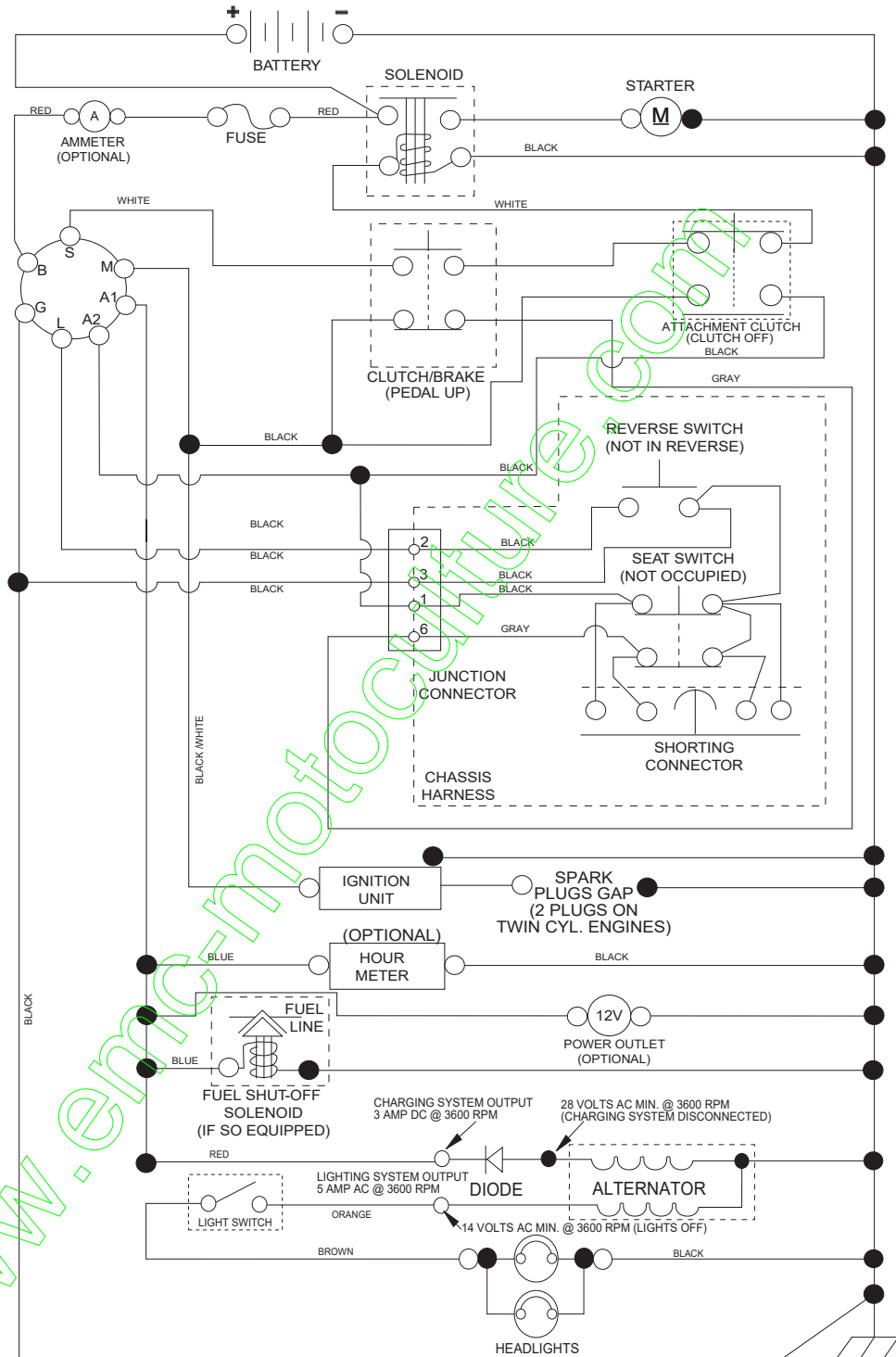

**NOTE**  
YOUR TRACTOR IS EQUIPPED WITH A SPECIAL ALTERNATOR SYSTEM. THE LIGHTS ARE NOT CONNECTED TO THE BATTERY, BUT HAVE THEIR OWN ELECTRICAL SOURCE. BECAUSE OF THIS, THE BRIGHTNESS OF THE LIGHTS WILL CHANGE WITH ENGINE SPEED. AT IDLE THE LIGHTS WILL DIM. AS THE ENGINE IS SPEEDED UP, THE LIGHTS WILL BECOME THEIR BRIGHTEST.

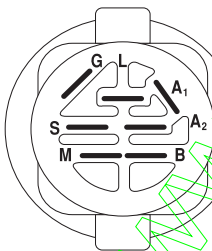

IGNITION SWITCH

POSITION	CIRCUIT	"MAKE"
OFF	M+G+A1	
RUN/OVERRIDE	B+A1	
RUN	B+A1	L+A2
START	B + S + A1	

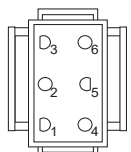

CHASSIS HARNESS CONNECTOR (MATING SIDE)

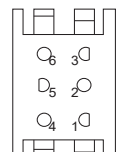

DASH HARNESS CONNECTOR (MATING SIDE)

WIRING INSULATED CLIPS  
NOTE: IF WIRING INSULATED CLIPS WERE REMOVED FOR SERVICING OF UNIT, THEY SHOULD BE RE-INSTALLED TO PROPERLY SECURE YOUR WIRING.

NON-REMOVABLE CONNECTIONS

REMOVABLE CONNECTIONS

**TRACTOR -- MODEL NUMBER LT2217A (96041004300), PRODUCT NO. 960 41 00-43  
ELECTRICAL**

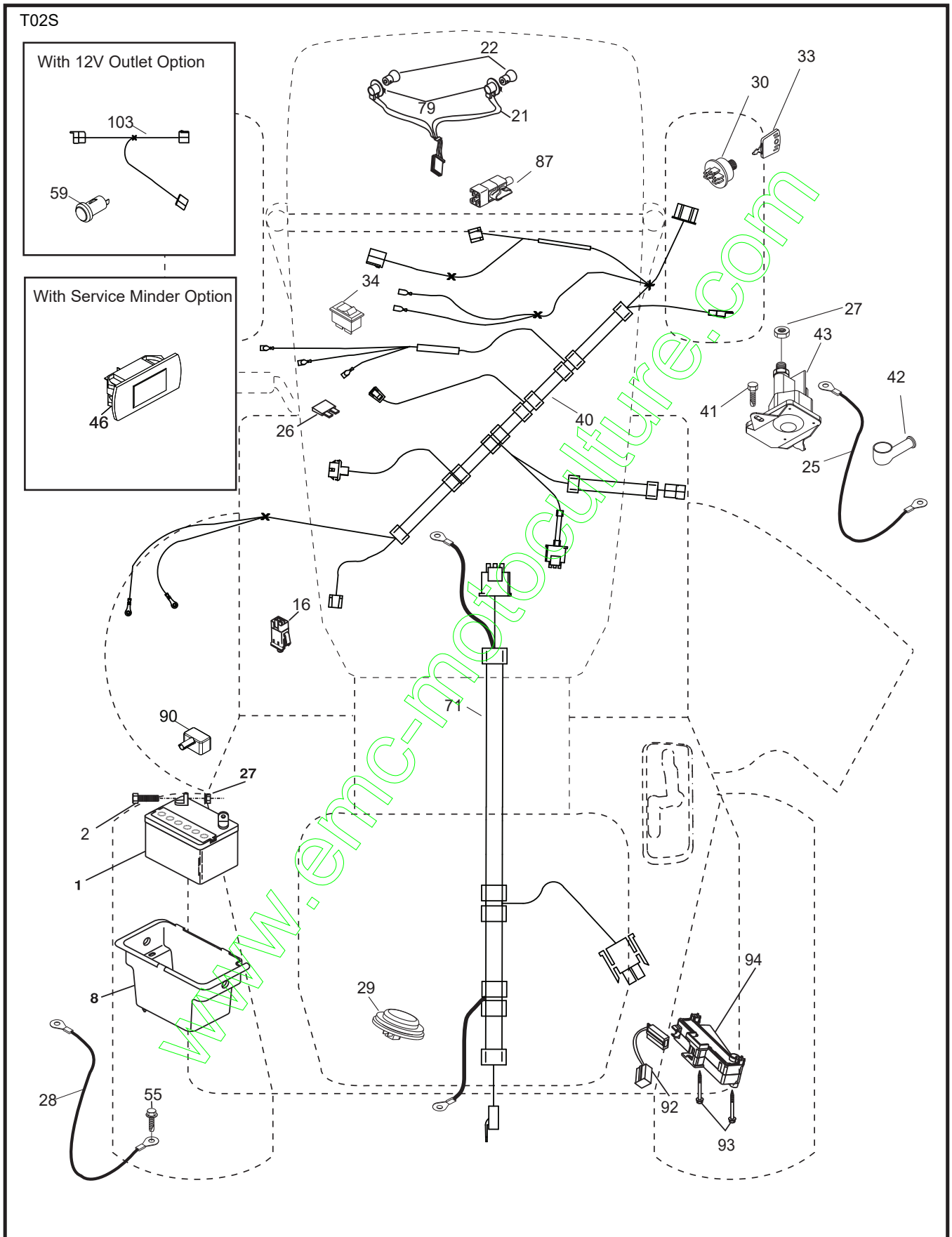

**TRACTOR - - MODEL NUMBER LT2217A (96041004300), PRODUCT NO. 960 41 00-43  
ELECTRICAL**

<b>KEY NO.</b>	<b>PART NO.</b>	<b>DESCRIPTION</b>
1	532 14 49-27	Battery
2	874 76 04-12	Bolt Hex Head 1/4-20 x 3/4
8	532 19 32-28	Box Battery
16	532 17 61-38	Switch Interlock Push-In
21	532 18 37-59	Harness Socket Light w/4152J
22	532 00 41-52	Bulb Light
25	532 40 16-62	Cable Starter
26	532 17 51-58	Fuse
27	873 51 04-00	Nut Keps Hex 1/4-20 unc
28	532 19 88-85	Cable, Ground
29	532 40 15-45	Switch, Seat
30	532 19 33-50	Switch, Ign
33	532 14 04-01	Key, Ignition
34	532 11 07-12	Switch Light/Reset
40	532 40 10-98	Harness Ign. Dash
41	817 72 04-08	Screw Thd Cut 1/4-20 x 1/2
42	532 13 15-63	Cover, Terminal
43	532 19 25-07	Solenoid
55	817 06 05-12	Screw Thdrol 5/16-18 x 3/4 TYTT
71	532 40 04-49	Harness Ign. Chassis
79	<b>532 17 52-42</b>	Socket Asm. Bulb Twistlock
87	<b>532 19 78-02</b>	Switch Interlock Clutch Cable
90	532 40 07-25	Cover Terminal
92	532 19 66-15	Harness Pigtail Reverse Switch
93	532 19 25-40	Screw Plastite 10-14 x 2.0
94	532 19 18-34	Module Reverse ROS

**NOTE:** All component dimensions given in U.S. inches  
1 inch = 25.4 mm

**TRACTOR - - MODEL NUMBER LT2217A (96041004300), PRODUCT NO. 960 41 00-43  
CHASSIS**

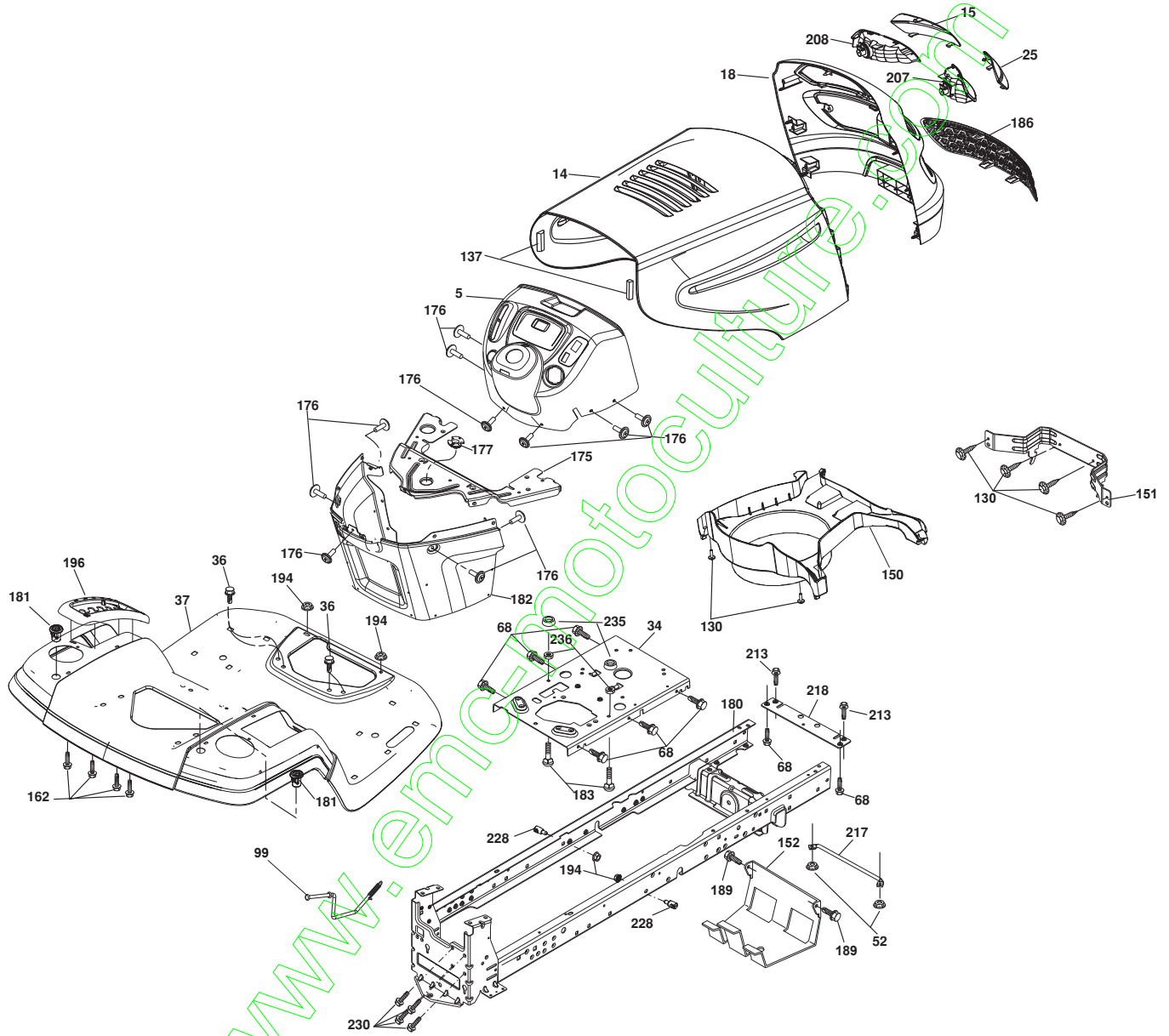

chassis-tex\_54-elite-sv-pro

**TRACTOR -- MODEL NUMBER LT2217A (96041004300), PRODUCT NO. 960 41 00-43  
CHASSIS**

KEY NO.	PART NO.	DESCRIPTION
5	532 41 12-79	Dash
14	532 19 47-57	Hood
15	532 18 97-54	Lens LH
18	532 19 29-15	Grille/Lens Asm.
25	532 18 97-55	Lens RH
34	532 19 61-25	Plate Engine
36	817 06 05-12	Screw 5/16-18 x 3/4
37	532 41 12-83	Fender
52	873 68 05-00	Nut Crown Lock 5/16
68	817 49 05-08	Screw THDROL 5/16-18 x 1/2
99	532 40 33-76	Rod Asm. Bypass
130	532 19 16-11	Screw 10 x 3/4 Single Lead-Hex
137	532 18 49-21	Bumper Dash
150	532 18 43-22	Air Duct
151	532 40 78-07	Bracket Pivot
152	532 19 95-35	Shield Browning
162	532 13 77-29	Screw
175	532 19 32-43	Crossmember
176	532 40 07-76	Screw 10-24 x 5/8
177	532 19 52-28	Bushing Steering
180	532 19 54-57	Chassis
181	532 40 47-96	Bushing Mtg. Fender Crgo
182	532 19 30-57	Dash Lower
183	874 78 05-20	Bolt 5/16-18 unc x 1-1/4
186	532 18 97-53	Insert Grille
189	817 00 05-12	Screw 5/16-18 x 3/4
194	873 90 05-00	Nut Lock Hex Flange 5/16-18
196	532 40 97-28	Console Asm. Deck Lift
207	532 18 38-33	Bezel Grille RH
208	532 18 38-32	Bezel Grille LH
213	874 76 05-12	Bolt 5/16-18 x 3/4
217	532 15 65-24	Rod Pivot Hood
218	532 19 63-95	X-Piece Hood Stop
228	532 19 51-61	Stud Fastener
230	532 17 01-65	Bolt Shoulder 5/16-18
235	532 40 61-29	Spacer Fender
236	873 93 05-00	Nut Lock 5/16-18 unc

**NOTE:** All component dimensions given in U.S. inches  
1 inch = 25.4 mm



TRACTOR - - MODEL NUMBER LT2217A (96041004300), PRODUCT NO. 960 41 00-43  
DRIVE

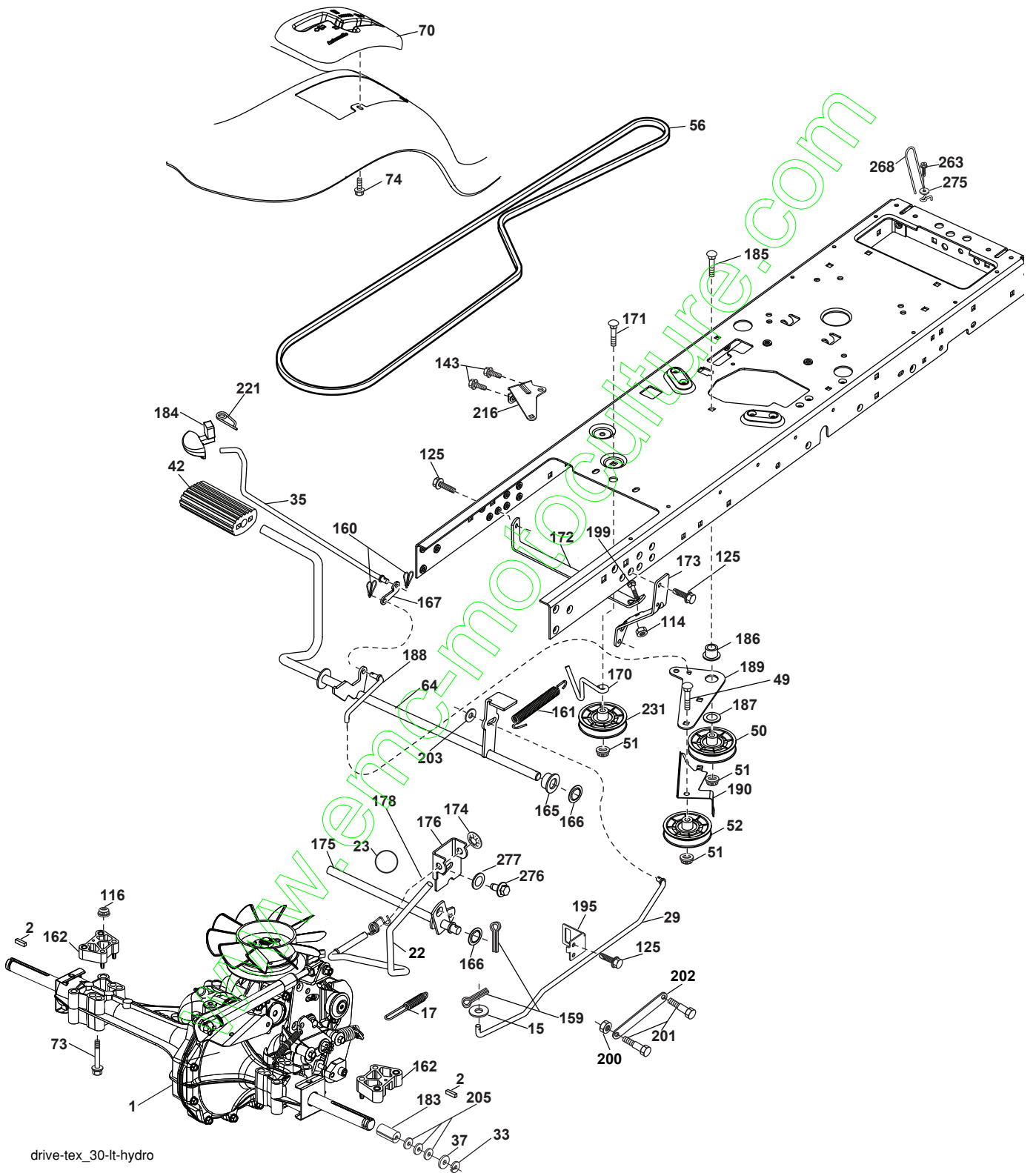

drive-tex\_30-lt-hydro

**TRACTOR -- MODEL NUMBER LT2217A (96041004300), PRODUCT NO. 960 41 00-43  
DRIVE**

KEY NO.	PART NO.	DESCRIPTION	KEY NO.	PART NO.	DESCRIPTION
1	-----	Transaxle, Hydro 351-0510 (Order Parts from Transaxle Manufacturer)	171	872 11 06-22	Bolt
2	532 12 35-83	Key Square	172	532 19 76-56	Strap Torque LH
15	819 13 13-16	Washer 13/32 x 13/16 x 16 Ga.	173	532 19 76-55	Strap Torque RH
17	532 19 72-96	Spring, Brake	174	532 19 72-89	Nut Push
22	532 19 76-60	Rod Shift	175	532 19 76-53	Shaft Asm. Shift
23	532 12 12-74	Knob Duckhead 1/2-13	176	532 19 62-14	Arm Clevis Rod Shift
29	532 19 76-59	Rod, Brake	178	532 19 74-56	Spring Shift
33	812 00 00-01	Ring E	183	532 13 70-57	Spacer Axle
35	532 19 77-22	Rod, Brake, Park	184	532 41 12-89	Handle Parking Brake
37	532 12 17-49	Washer 25/32 x 1-1/4 x 16 Ga.	185	872 11 06-20	Bolt
42	532 12 48-72	Cover, Foot Pedal	186	532 19 43-21	Spacer Retainer
49	872 11 06-14	Bolt	187	819 13 32-10	Washer
50	532 19 43-27	Pulley Idler Flat	188	532 19 43-23	Link Clutch Ground Drive
51	873 90 06-00	Lock Nut 3/8-16	189	532 19 43-17	Bellcrank Ground Drive
52	532 19 43-26	Idler V-Groove 910" Offset	190	532 19 43-18	Keeper Bellcrank Ground Drive
56	532 14 02-18	V-Belt, Drive	195	532 19 80-12	Bracket Brake Rod
64	532 19 62-00	Shaft Asm. Pedal Brake Control	199	872 14 05-08	Bolt 5/16-18 unc x 1
70	532 41 13-29	Console	200	873 93 05-00	Nut Center Lock 5/16-18 unc
73	874 49 05-60	Bolt 5/16-18 Gr. 5	201	532 16 96-12	Bolt Shoulder 5/16
74	532 14 24-32	Screw 1/4 x 1/2	202	532 19 77-15	Link Transaxle
114	873 80 05-00	Nut Lock 5/16-18 unc	203	819 11 11-16	Washer 11/32 x 11/16 x 16 Ga.
116	873 90 05-00	Nut Lock Hex Flange 5/16-18	205	532 12 17-48	Washer 25/32 x 1-5/8 16 Ga.
125	817 00 05-12	Screw 5/16-18 x 3/4	216	532 19 61-31	Bracket Pulley Idler
143	817 49 05-08	Screw 5/16-18 x 1/2	221	532 40 31-87	Retainer Spring Clip Handle
159	876 02 04-12	Pin Cotter 1/8 x 3/4	231	532 40 72-87	Idler Y Groove
160	532 16 94-84	Retainer Clip	263	817 00 06-12	Screw Hex Wsh Thdrol 3/8 - 16 x 3/4
161	532 19 54-03	Spring, Return, Clutch	268	532 18 24-02	Guard Muffler
162	532 19 57-85	Spacer Transaxle	275	819 13 16-14	Washer 13/32 x 1 x 14
165	532 19 62-12	Bushing Shaft Brake Hand Control	276	874 78 07-16	Bolt Fin Hex 7/16-14 x 1 Gr. 5
166	532 19 72-90	Nut Push .625	277	532 40 52-96	Washer Serrated
167	532 40 52-57	Latch Brake Parking			
170	532 19 43-22	Keeper Belt Centerspan			

**NOTE:** All component dimensions given in U.S. inches  
1 inch = 25.4 mm

www.emc-motors.com

**TRACTOR - - MODEL NUMBER LT2217A (96041004300), PRODUCT NO. 960 41 00-43  
ENGINE**

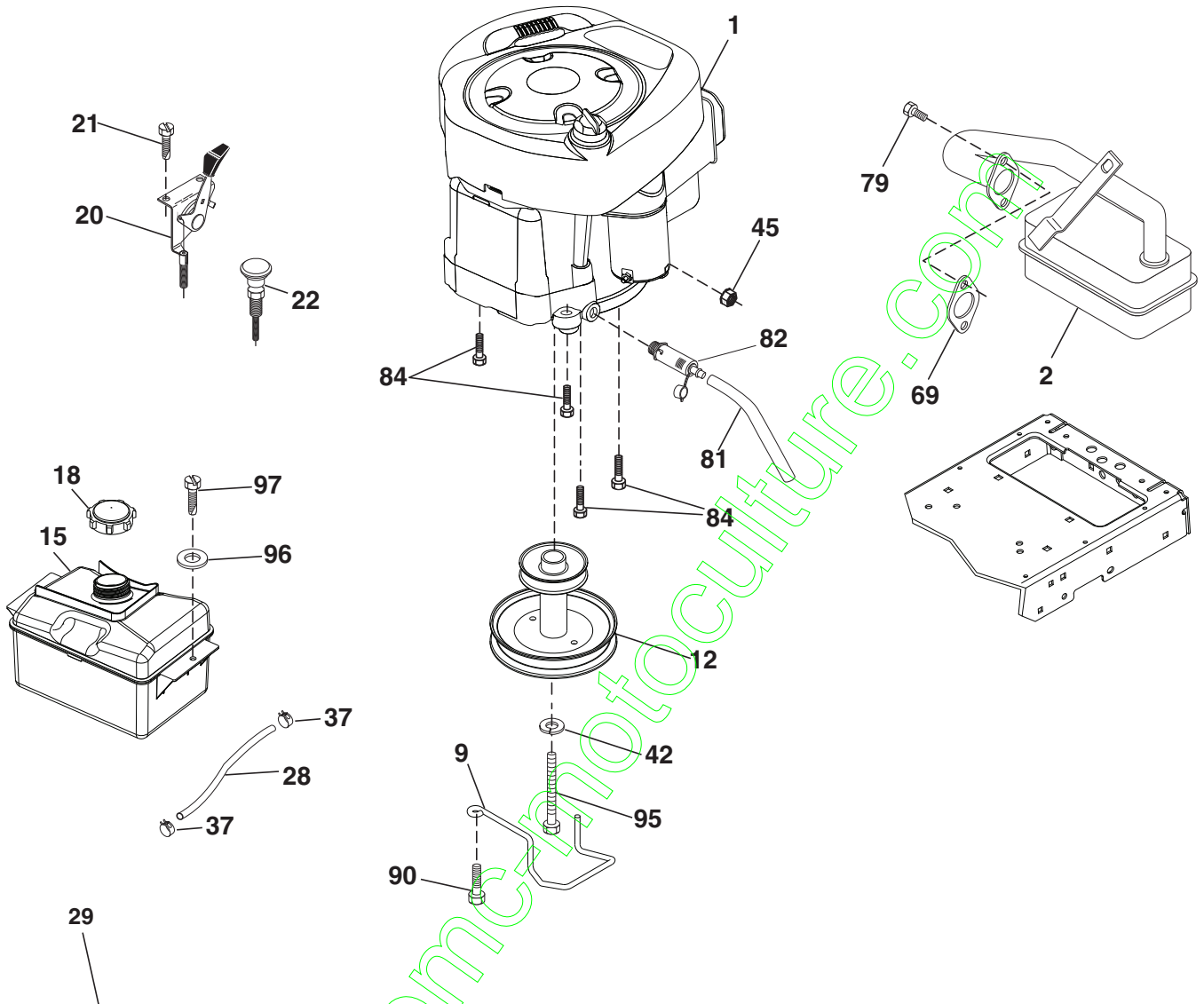

**OPTIONAL EQUIPMENT**  
**Spark Arrester**

engine-bs-1cyl-tex\_8\_r1

**TRACTOR -- MODEL NUMBER LT2217A (96041004300), PRODUCT NO. 960 41 00-43  
ENGINE**

KEY NO.	PART NO.	DESCRIPTION
1	-----	Engine BS Model No. 31E777
2	532 13 73-52	Muffler
9	532 19 43-19	Keeper Belt Engine
12	532 40 19-85	Pulley Engine
15	532 40 75-45	Tank Fuel 1.5
18	532 19 77-25	Cap Asm
20	532 18 38-97	Control Throttle
21	532 19 16-11	Screw 10 x 3/4 Single Lead-Hex
22	532 19 49-81	Control Choke ERGO
28	532 13 70-40	Fuel Line
29	532 13 71-80	Spark Arrester Kit
37	532 12 34-87	Clamp Hose
42	810 04 07-00	Washer Lock Hvy HLCL SPR 7/16
45	873 51 04-00	Nut Keps Hex 1/4-20 unc
69	532 16 52-91	Gasket
79	532 19 23-34	Screw Socket HD 5/16 - 18 x 75
81	532 14 84-56	Tube Drain Oil Easy
82	532 18 16-54	Plug Drain Oil
84	817 06 06-20	Screw 3/8 - 16 x 1-1/4
90	817 00 06-16	Screw 3/8-16 x 1
95	532 17 39-37	Bolt Hex 7/16 - 20 x 4
96	819 09 14-16	Washer 9/32 x 7/8 x 16 Ga.
97	817 67 04-12	Screw 1/4 - 20 x 3/4

**NOTE:** All component dimensions given in U.S. inches  
1 inch = 25.4 mm

**Engine Power Rating Information**

The gross power rating for individual gas engine models is labeled in accordance with SAE (Society of Automotive Engineers) code J11940 (Small Engine Power & Torque Rating Procedure), and rating performance has been obtained and corrected in accordance with SAE J1995 (Revision 2002-5). Actual gross engine power will be lower and is affected by, among other things, ambient operating conditions and engine-to-engine variability. Given both the wide array of products on which engines are placed and the variety of environmental issues applicable to operating the equipment, the gas engine will not develop the rated gross power when used in a given piece of power equipment (actual "on-site" or net horsepower). This difference is due to a variety of factors including, but not limited to, accessories (air cleaner, exhaust, charging, cooling, carburetor, fuel pump, etc.), application limitations, ambient operating conditions (temperature, humidity, altitude), and engine-to-engine variability. Due to manufacturing and capacity limitations, Briggs & Stratton may substitute an engine of higher rated power for this Series engine.

**TRACTOR - - MODEL NUMBER LT2217A (96041004300), PRODUCT NO. 960 41 00-43  
STEERING ASSEMBLY**

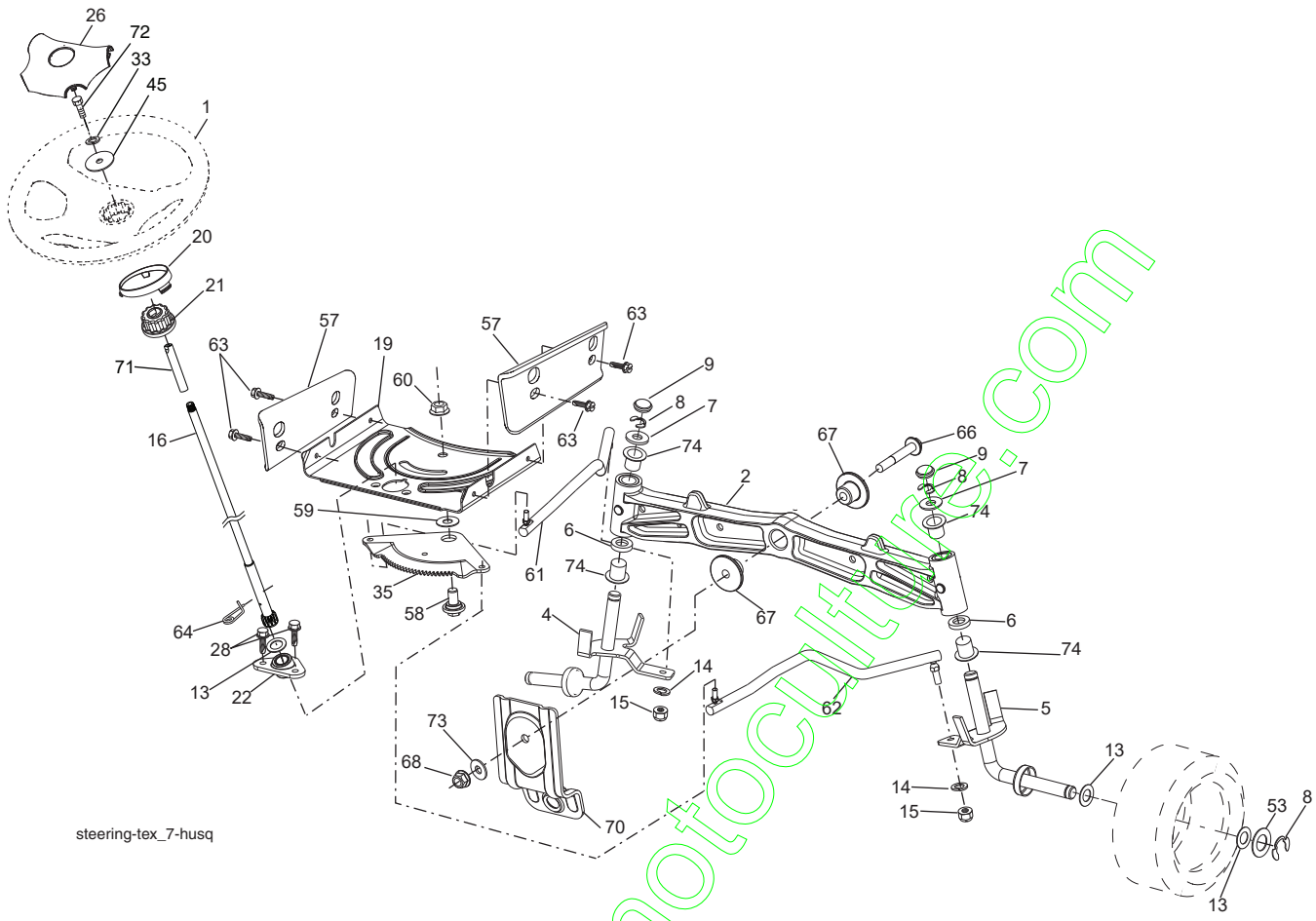

steering-tex\_7\_husq

KEY NO.	PART NO.	DESCRIPTION	KEY NO.	PART NO.	DESCRIPTION
1	532 19 46-37	Wheel, Steering	53	532 18 89-67	Washer Hardened .793x1.637x.060
2	532 19 56-73	Axle Asm., Front	57	532 40 74-65	Bracket Upstop
4	532 40 30-87	Spindle Asm., LH	58	532 19 47-47	Bolt Shoulder Sector Pivot CFM
5	532 40 30-88	Spindle Asm., RH	59	532 19 47-48	Washer Thrust Sector Steering
6	532 12 49-31	Bearing, Race Thrust Harden	60	873 97 10-00	Nut Flange Lock 5/8-11
7	532 12 17-48	Washer 25/32 x 1-5/8 x 16 Ga.	61	532 19 47-40	Draglink LH
8	812 00 00-29	Ring, Clip #T5304-75	62	532 19 47-41	Draglink, RH
9	532 12 12-32	Cap, Spindle	63	817 00 05-12	Screw 5/16-18 x 3/4
13	532 12 17-49	Washer 25/32 x 1-1/4 x 16 Ga.	64	532 19 98-49	Retainer Clip Spring Steering
14	810 04 06-00	Washer, Lock Hvy Hlcl Spr 3/8	66	871 02 07-48	Bolt Hex Fghd 7/16-14 x 3 Serr
15	873 54 06-00	Nut, Crown Lock 3/8-24 unf	67	532 19 47-37	Bushing PM Front Axle
16	532 19 60-74	Shaft Steering	68	873 90 07-00	Nut Lock Flange 7/16-14 Gr. 5
19	532 19 47-29	Plate Steering	70	532 19 61-97	Bracket Deck Susp. Front
20	532 41 12-91	Boot, Steering	71	532 19 60-75	Shaft Extension Steering
21	532 18 67-37	Adapter, Wheel Steering	72	874 78 05-72	Bolt 5/16-18 unc x 4.5. Gr. 5
22	532 19 48-45	Bushing, Strg. Blk	73	532 19 91-62	Washer 1.5 x .505 x .118
26	532 19 46-03	Insert, Wheel Steering	74	532 12 49-37	Bearing
28	817 00 06-12	Screw 3/8-16 x 3/4			
33	810 04 05-00	Washer Lock 5/16			
35	532 19 47-32	Gear, Sector Plate			
45	819 11 38-12	Washer 11/32 x 3/8 x 12 Ga.			

**NOTE:** All component dimensions given in U.S. inches  
1 inch = 25.4 mm

**TRACTOR -- MODEL NUMBER LT2217A (96041004300), PRODUCT NO. 960 41 00-43  
SEAT ASSEMBLY**

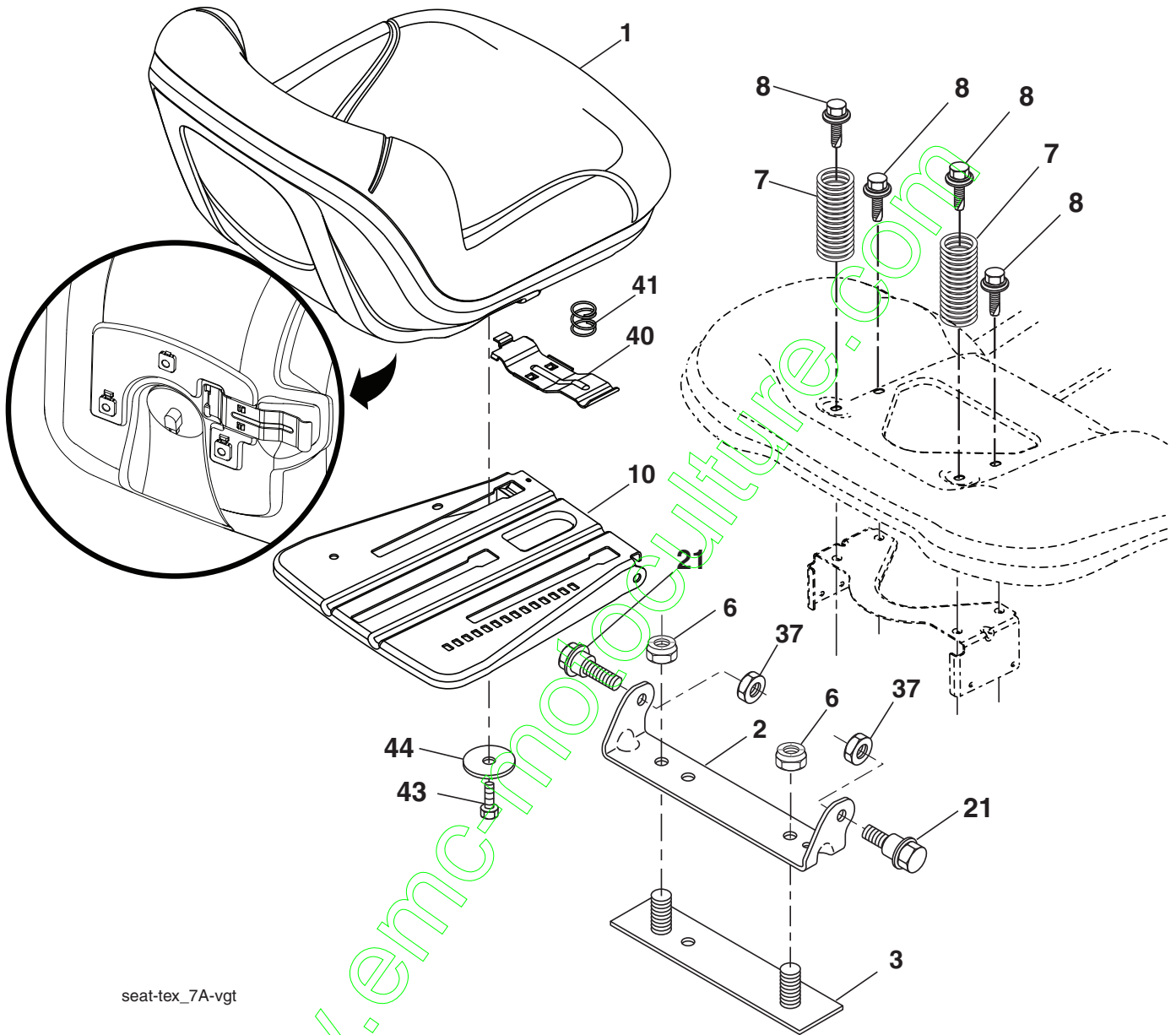

seat-tex\_7A-vgt

KEY NO.	PART NO.	DESCRIPTION
1	532 19 75-11	Seat
2	532 18 01-66	Bracket Pivot Fender
3	532 14 06-75	Strap, Asm Fender
6	873 80 06-00	Nut, Lock w/Ins. 3/8-16 unc
7	532 12 41-81	Spring, Seat Cprsn
8	532 17 18-77	Bolt 5/16-18 unc x 3/4 w/Sems
10	532 19 69-77	Pan, Seat
21	532 17 18-52	Bolt, Shoulder 5/16-18

KEY NO.	PART NO.	DESCRIPTION
37	873 80 05-00	Nut, Lock 5/16-18 unc
40	532 19 76-61	Handle Slide Seat
41	532 19 82-00	Spring Latch Seat
43	874 76 06-12	Bolt 3/8-16 x 3/4
44	819 13 38-12	Washer 13/32 x 2-3/8 x 12 Ga.

**NOTE:** All component dimensions given in U.S. inches  
1 inch = 25.4 mm

**TRACTOR - - MODEL NUMBER LT2217A (96041004300), PRODUCT NO. 960 41 00-43  
MOWER DECK**

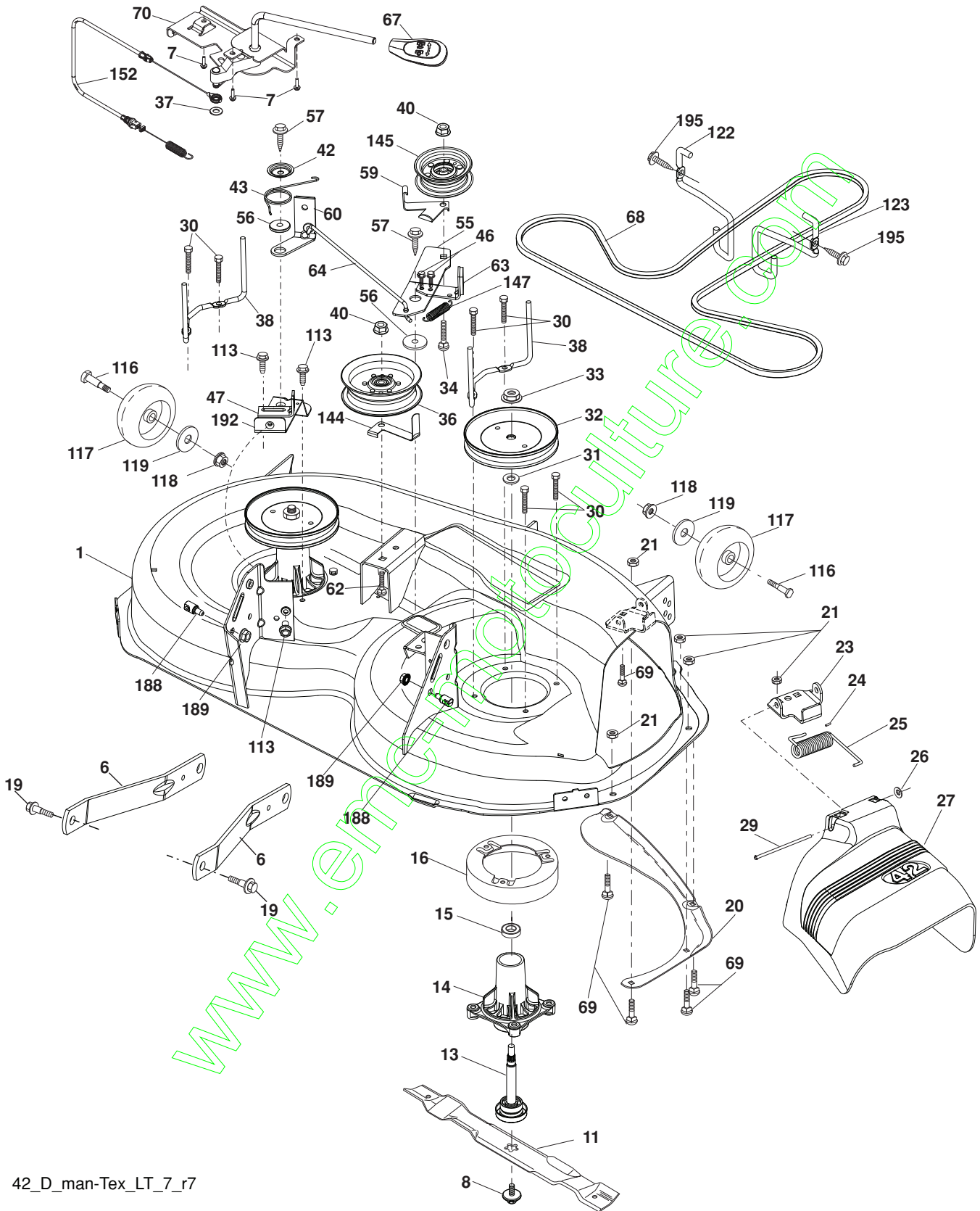

42\_D\_man-Tex\_LT\_7\_r7

**TRACTOR - - MODEL NUMBER LT2217A (96041004300), PRODUCT NO. 960 41 00-43  
MOWER DECK**

KEY NO.	PART NO.	DESCRIPTION	KEY NO.	PART NO.	DESCRIPTION
1	532 19 64-95	Mower Housing	57	817 00 06-16	Screw 3/8-16 x 1
6	532 19 51-86	Arm Suspension	59	532 14 10-43	Guard, Tuv Idler
7	532 41 63-58	Screw #10 x 0.750 BOS Thread	60	532 19 72-61	Arm Brake Mower
8	532 19 30-03	Bolt/Washer Asm 7/16-20 unf	62	872 11 06-16	Bolt 3/8-16 unc x 2
11	532 13 89-71	Blade Mower 42" Hi Lift Premium (For better wear when mulching)	63	532 19 94-77	Arm Brake Mower
13	532 19 28-72	Shaft Assembly, Mandrel	64	532 19 97-90	Link Brake
14	532 18 72-81	Housing, Mandrel	67	532 40 30-12	Handle Clutch Cable
15	532 11 04-85	Bearing, Ball, Mandrel	68	532 19 72-53	V-Belt
16	532 17 44-93	Stripper Mandrel Deck	69	872 14 05-05	Bolt
19	532 19 65-39	Bolt, Shoulder	70	532 19 83-32	Clutch Asm Manual
20	532 15 97-70	Baffle Vortex	113	817 00 05-10	Screw 5/16-18
21	873 68 05-00	Nut, Crownlock 5/16-18 unc	116	532 12 48-42	Bolt Shoulder
23	532 19 25-57	Bracket, Deflector	117	532 18 86-06	Wheel Gauge
24	532 10 53-04	Cap, Sleeve	118	873 93 06-00	Nut Centerlock 3/8-16 unc
25	532 19 70-26	Spring, Torsion, Deflector	119	819 12 14-14	Washer 3/8 x 7/8 x 14 Ga.
26	532 11 04-52	Nut, Push	122	532 19 72-58	Keeper Belt Engine LH
27	532 40 30-04	Shield, Deflector	123	532 19 72-59	Keeper Belt Engine RH
29	532 13 14-91	Rod, Hinge	144	532 19 92-04	Keeper Belt
30	532 17 39-84	Screw Thdrol Rolling Wsh Hd	145	532 19 31-97	Pulley Idler
31	532 18 76-90	Washer, Spacer	147	532 40 19-71	Spring Return
32	532 19 74-73	Pulley, Mandrel	152	532 40 87-14	Manual Clutch Cable
33	532 40 02-34	Nut, Toplock, Flanged	188	532 19 51-61	Stud Fastener
34	872 11 06-12	Bolt Carr Sh. 3/8-16 x 1-1/2 Gr. 5	189	873 90 05-00	Nut Lock Hex Flange
36	532 19 73-79	Pulley, Idler, Flat	192	532 19 72-60	Bracket Brake Stand LH
37	819 13 13-16	Washer	195	817 00 06-12	Screw 3/8-16 x 3/4
38	532 19 91-89	Keeper Belt LH Mandrel	--	532 19 28-70	Mandrel Assembly (Includes housing, shaft assembly, and bearing only - pulley/nut/washer and blade bolt/washers not included)
40	873 90 06-00	Nut, Lock Flg. 3/8-16 unc	--	532 19 96-08	Replacement Mower, Complete
42	532 19 84-10	Spring Torsion Brake			
43	532 19 72-56	Spring Torsion Retainer			
46	532 13 77-29	Screw 1/4-20 x 5/8			
47	532 19 72-50	Bracket Clutch Cable			
55	532 19 72-49	Arm, Idler			
56	532 19 90-92	Spacer, Retainer			

**NOTE:** All component dimensions given in U.S. inches  
1 inch = 25.4 mm



**TRACTOR -- MODEL NUMBER LT2217A (96041004300), PRODUCT NO. 960 41 00-43  
MOWER LIFT**

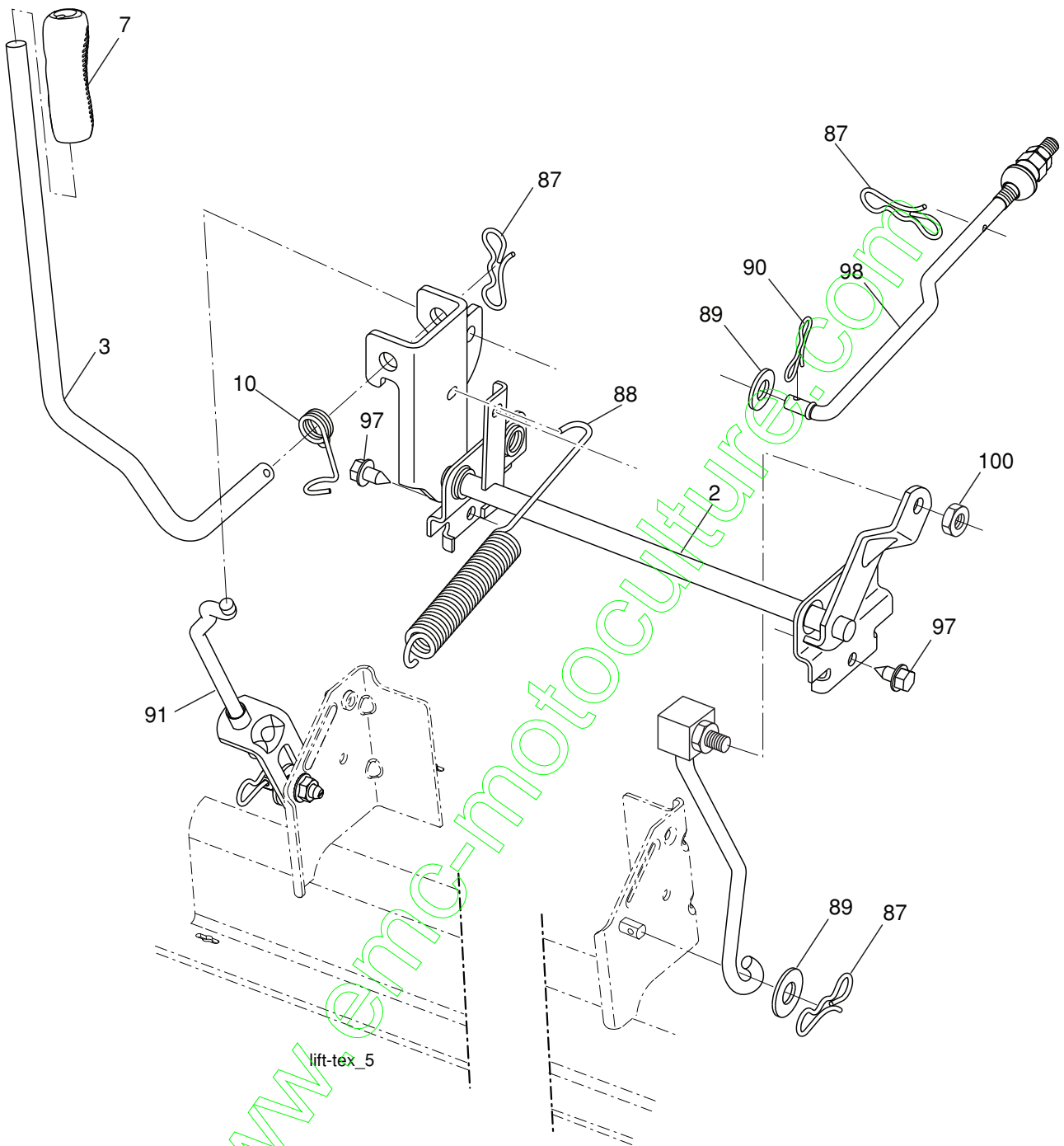

KEY NO.	PART NO.	DESCRIPTION
2	532 19 52-23	Shaft Asm., Lift
3	532 19 52-31	Lever Asm., Lift RH
7	532 41 15-55	Grip, Lever
10	532 19 63-14	Spring Torsion
87	532 19 42-09	Pin Cotter 7/16 Bow Tie Lock
88	532 19 53-03	Spring Lift Assist
89	819 19 19-12	Washer Clear Zinc
90	532 19 42-08	Pin Cotter 5/16 Bow Tie Lock

KEY NO.	PART NO.	DESCRIPTION
91	532 19 51-81	Link Lift Susp Mower Rear
97	817 06 06-12	Screw 3/8-16 x .75 Smgml Tap/R.Z
98	532 19 52-70	Link Lift Susp. Front Mower
100	873 93 06-00	Nut Centerlock 3/8-16

**NOTE:** All component dimensions given in U.S. inches  
1 inch = 25.4 mm