

# LT 4140H

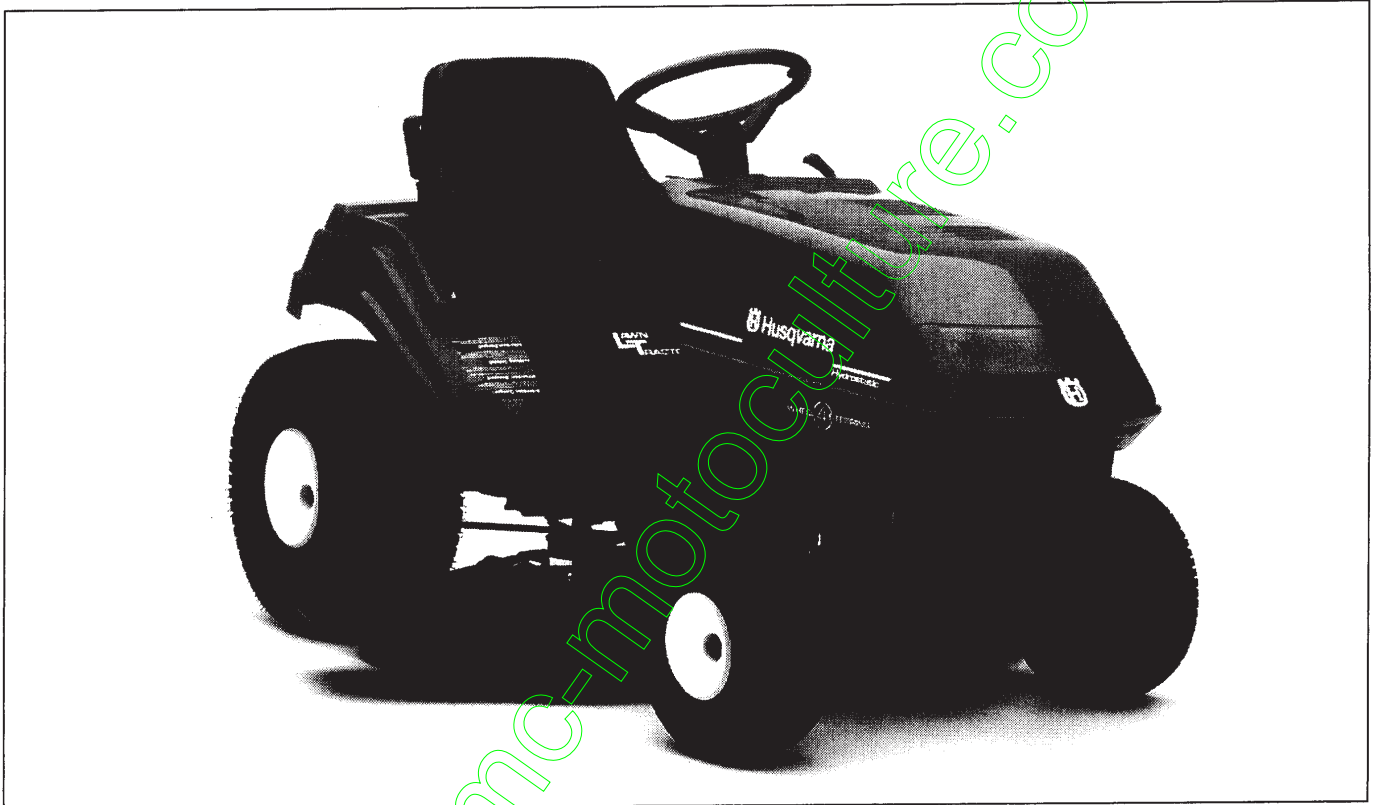

**1.1994**

**Spare parts**

**Ersatzteile**

**Pièces détachées**

**Reserveonderdelen**

**Repuestos**

**Reservdelar**

**Replaces**

**Ersetzt**

**Remplace**

**Vervangt**

**Reemplaza**

**Ersätter**

**106 23 01-61**

A

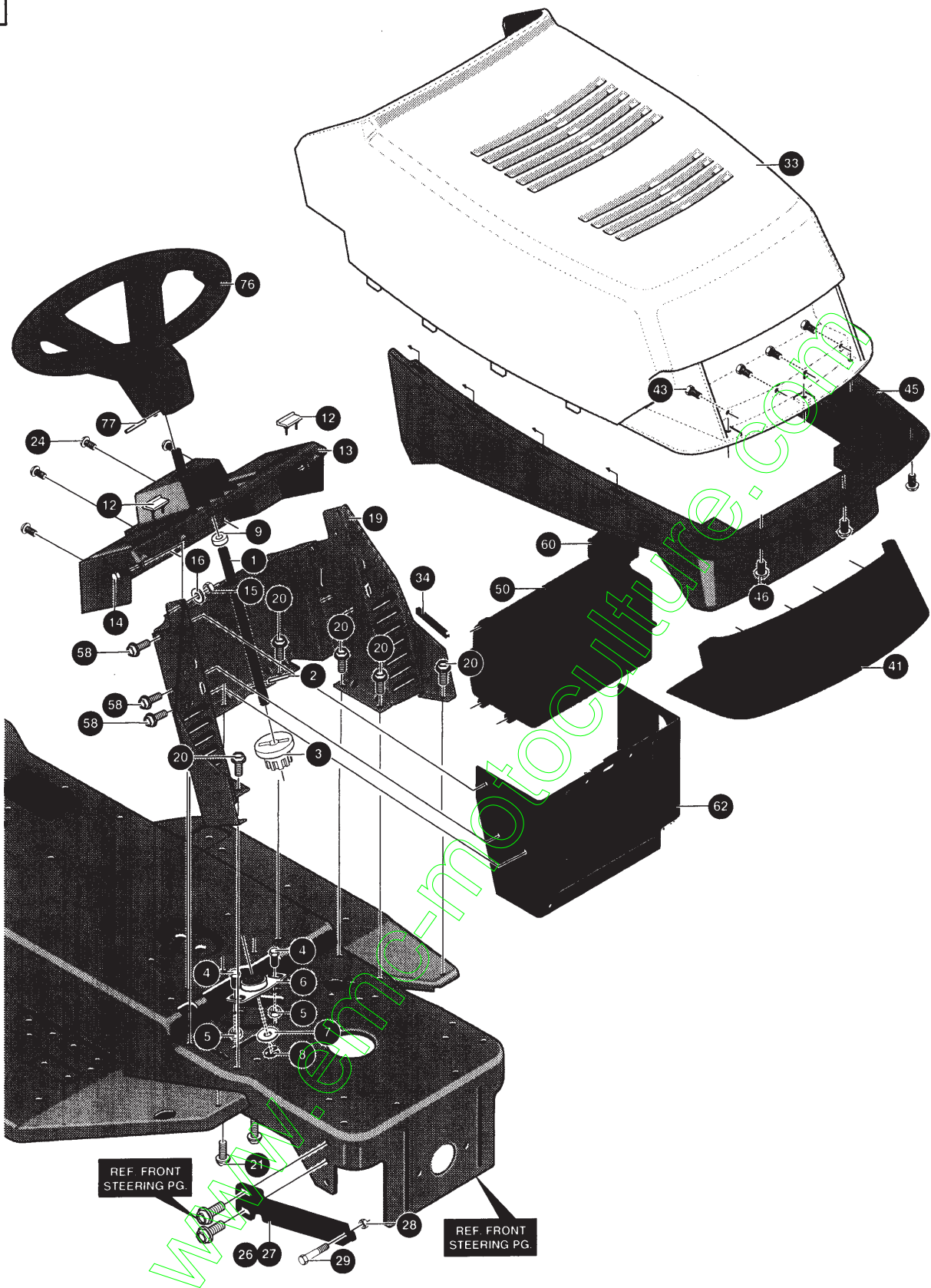

KEY#	PART #	DESCRIPTION	QTY.
1	533 30 23-07	SHAFT, STEKRING EURO LT SMORT.....	1
2	533 30 25-24	PIN DOWEL STR ERO LT .....	1
3	533 30 23-14	PINJON, STEERING.....	1
4	533 32 37-31	SCREW, 5/16-24X.75 (TQ 30-35 FT#).....	2
5	533 07 11-00	NUT, 5/16-24 HEXWDFLLK.....	2
6	533 30 24-98	BEARING, FLANGED .5001 DX . ODX .75.....	1
7	533 00 29-68	WASHER, FLAT .504X .75X.059.....	1
8	533 02 08-64	RING, RET E .39X.04TRU513350.....	1
9	533 30 32-28	BUSHING STR SHIFT UPPER.....	1
12	533 32 18-10	BUMPER,HOOD/DASH EURO TOP.....	2
13	533 33 13-79	DASH, TALL .....	1
14	874 78 04-14	SCREW, 1/4-20X .75 HHC .....	2
15	533 00 15-02	NUT, 1/4-20 REGHEXCTRLK .....	2
16	533 12 03-92	WASHER, FLAT .281X .63X.065.....	2
19	533 30 23-31	DASH LOWER SMORT LT .....	1
20	533 03 54-97	SCREW, 5/16-18X .50 WAHHTAP.....	8
21	533 04 52-63	SCREW, 5/16-18X .37 WAHHTAP .....	2
23	533 99 53-46	SCREW, 1/4-20X .50 WAHHTAP.....	2
24	533 30 58-50	SCREW, 1/4-20X.50PHPNTAP .....	4
26	533 30 88-98	BRACKET, HOOD RH H19/G16.....	1
27	533 30 88-97	BRACKET, HOOD LH .....	1
28	533 00 14-98	NUT, 5/16-18 REGHEXCTRLK .....	2
29	533 02 50-86	BOLT, .500X .375 HSSH 5/16 18 .....	2
33	533 33 21-33	HOOD, UPPER.....	1
34	533 05 21-51	EDGING,WIDE BLK .....	78"
41	533 30 68-58	LENS, HOOD SMOKED GREY .....	1
43	533 30 03-02	SCREW, #10 X .50 HHTAPPST.....	4
45	533 33 11-84	GRILLE, MOLD/GREY .....	1
46	533 31 83-04	SCREW, 1/4-14X.75PHPNHTAP .....	3
50	533 30 58-20	ASSY GAS TANK 1.5GAL (OPTION).....	1
58	533 30 03-03	SCREW, .25X.75X.51HHWAPLASTITE.....	6
60	533 01 25-01	CAP,FUEL 2.5" THROAT.....	1
62	533 32 47-95	HEAT SHIELD ERO 1.5 & 3 GAL .....	1
76	533 33 08-47	STEKRING WHEEL.....	1
77	533 45 63-78	PIN, SPRING.250DIA X2.00LG HVPL.....	1

www.emc-motors.com

**B**

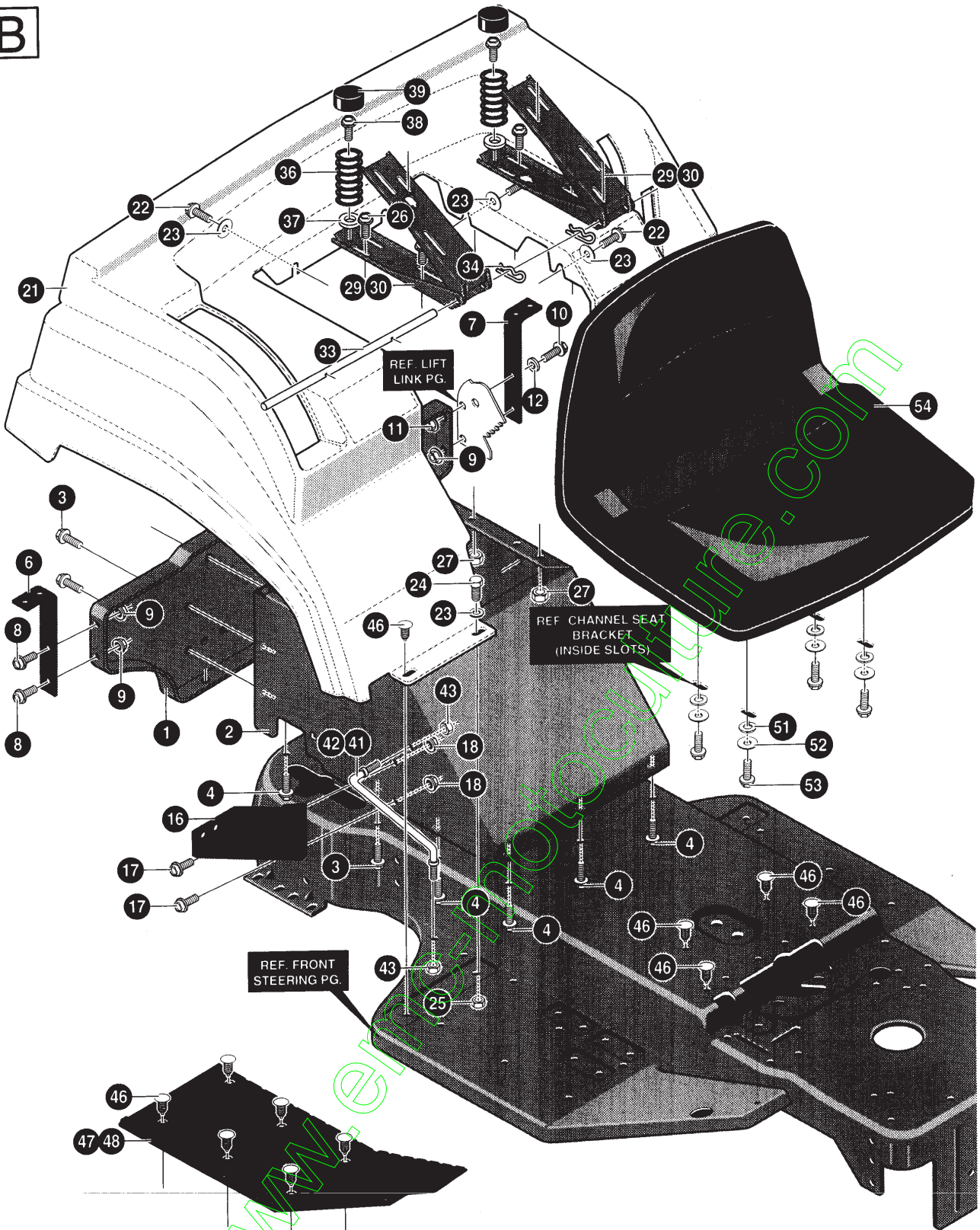

KEY #	PART #	DESCRIPTION	QTY.
1	533 32 20-68	SKAT SUPPORT ELECTRIC LIFT.....	1
2	533 32 20-69	SUPT,FENDER&SEAT ELECT/LIFT .....	1
3	533 03 54-98	SCREW, 5/16-18X .75 WAHHTAP .....	5
4	533 03 54-97	SCREW, 5/16-18X .50 WAHHTAP .....	10
6	533 30 63-99	SUPPORT FENDER RIGHT.....	1
7	533 30 63-97	SUPPORT FENDER LEFT .....	1
8	533 05 60-30	SCREW 5/16-18X.75WDFLLK .....	3
9	533 05 52-73	NUT, 5/16-18 HXWDFLLK .....	3
10	874 78 04-14	SCREW, 1/4-20X .75 HHC .....	1
11	533 05 13-35	NUT, 1/4-20 WDFLWHIZ-LK.....	1
12	533 12 03-85	WASHER, FLAT .250X .56X.049.....	1
16	533 30 53-81	SUPPORT, SHIFT PLATE .....	1
17	533 05 60-30	SCREW, 5/16-18X.75WDFLLK .....	2
18	533 05 52-73	NUT, 5/16-18 HXWDFLLK .....	2
21	533 31 05-76	FENDER,EURO F-10 GT MOLD GREY.....	1
22	533 04 48-11	SCREW, 1/4-20X .75 WAHHTAP .....	6
23	734 11 52-01	WASHER, FLAT .281X1.00X.063PL.....	8
24	874 78 04-14	SCREW, 1/4-20X .75 HHC .....	2
25	533 00 15-02	NUT, 1/4-20 REGHEXCTRLK.....	2
26	533 05 60-30	SCREW, 5/16-18 HXWDFLLK .....	4
27	533 00 14-98	NUT 5/16-18 REGHEXCTRLK.....	4
29	533 30 28-97	CHANNEL SKAT RH .....	2
30	533 30 54-24	CHANNEL SKAT LH .....	2
33	533 30 44-81	ROD, SKAT SUPPORT BRZN .....	1
34	533 03 63-68	PIN, HAIR .072 DIA X1.13LG .....	2
36	533 30 55-20	SPRING, SKAT 1.500DX2.25LG .....	2
37	533 12 03-93	WASHER, FLAT .344X .69X.065.....	2
38	533 03 54-98	SCREW, 5/16-18X .75 WAHHTAP .....	2
39	533 05 69-07	COVER, SKAT SPRING 1.51DX1.0LG .....	2
41	533 31 93-88	SUPPORT,FOOTREST STIFNR RH ZPL.....	1
42	533 31 93-87	SUPPORT,FOOTREST STIFNR LH ZPL.....	1
43	533 00 14-98	NUT, 5/16-18 REGHEXCTRLK .....	4
46	533 30 92-35	FASTENEK, RATCHET BLACK.....	18
47	533 31 48-88	FOOT PAD, ASSYRH ERO W/ADH.....	1
48	533 31 48-89	FOOT PAD, ASSYLH ERO W/ADH.....	1
51	533 12 03-93	WASHER, FLAT .344X .69X.065.....	4
52	533 12 06-38	WASHER, HVSP7LK .328X.60X.09.....	4
53	533 18 00-77	SCREW, 5/16-18X .75 HHC .....	4
54	533 31 03-84	SKAT, W/SW HOLK.....	1

www.emc-machinery.com



C

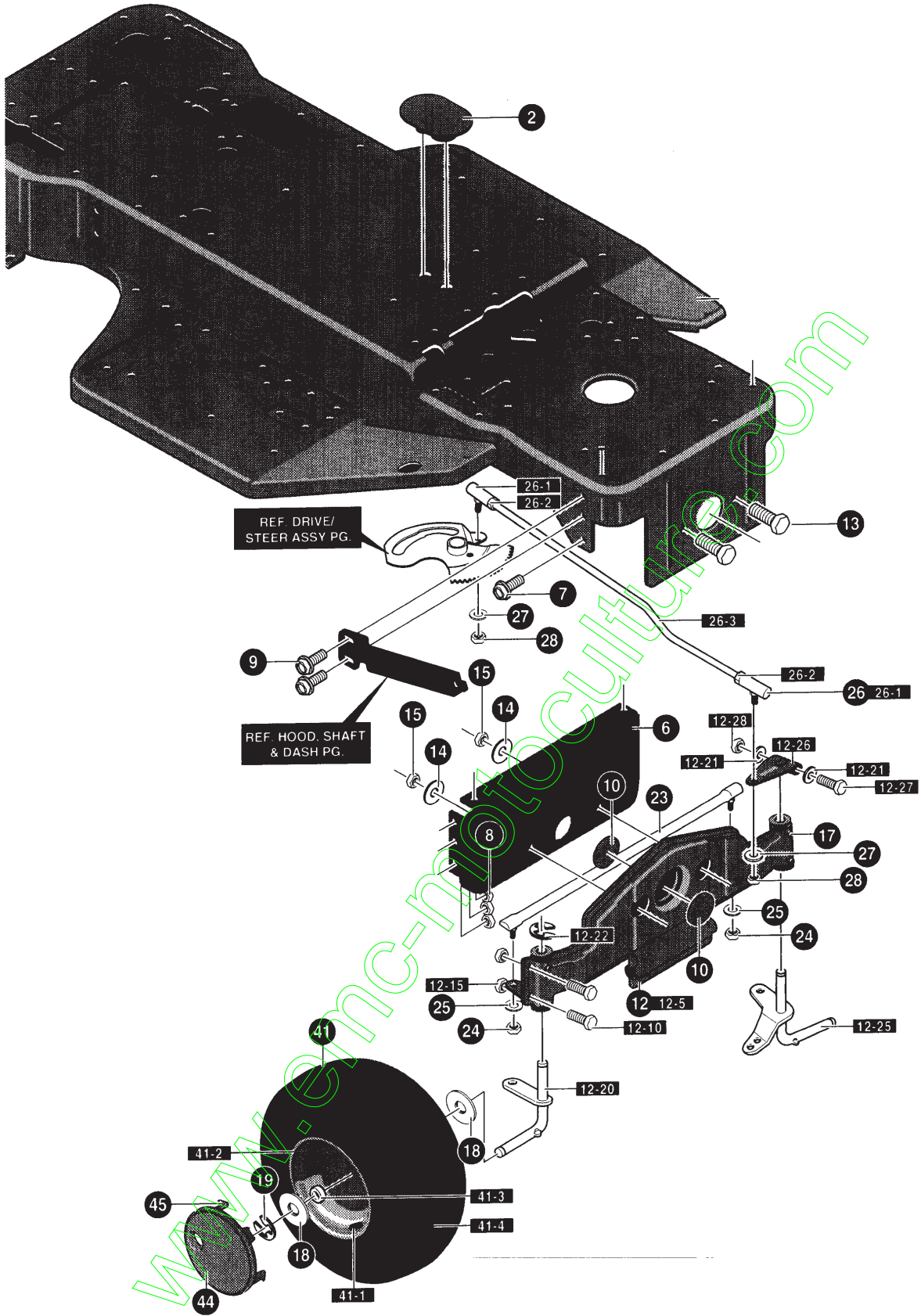

KEY#	PART#	DESCRIPTION	QTY
2	533 30 52-80	COVER,SECTOR BOLT PLAS GREY.....	1
6	533 30 23-21	BRACKET, FRONT AXLE SUPPORT .....	1
7	533 05 60-30	SCREW 5/16-18X.75WDFLLK .....	2
8	533 05 52-73	NUT, 5/16-18 HXWDFLLK .....	6
9	533 05 36-52	SCREW, 5/16-18X.75 HXWDFL .....	4
10	533 30 71-12	PLUG,FRONTAXLE 1.938DIAX.062.....	2
12	^	SUB-ASSY FR AX ERO LT SMORT .....	1
12-5	533 31 06-70	AXLE,ASSY FRONT WELD BLK.....	1
12-10	533 18 00-77	SCREW, 5/16-18X .75 HHC .....	4
12-15	533 00 14-98	NUT, 5/16-18 REGHEXCTRLK .....	4
12-20	533 30 53-40	ASSY SPDLE RH EROLT .....	1
12-21	533 99 64-16	WASHER, FLAT .391X1.00X.125.....	2
12-22	533 03 66-25	RING, RETEX .57X.05TRU513375 .....	2
12-25	533 30 53-39	ASSY SPDLE LH EROLT .....	1
12-26	533 31 70-19	ARM STEKRING UPPER BLACK .....	1
12-27	533 18 01-34	SCREW, 3/8-16X2.50 HHC .....	1
12-28	533 00 14-99	NUT, 3/8-16 REGHXCTRLK .....	1
13	874 78 06-48	SCREW, 3/8-16X3.00 HHC .....	2
14	533 00 24-83	WASHER,.391DX1.25DX.07 BELLVIL .....	2
15	533 00 14-99	NUT, 3/8-16 REGHXCTRLK .....	2
17	533 00 07-06	ZERK, GREASE FITTING .....	4
18	533 00 06-42	WASHER, FLAT .755X1.31X.075 .....	4
19	533 03 66-25	RING, RETEX .57X.05TRU513375 .....	2
23	533 30 03-28	TIE ROD .625DIA GRND ENGAGER .....	1
24	533 12 03-69	NUT, 3/8-24 REGHEX.....	2
25	533 12 03-82	WASHER, REGSPTLK.393X.68X.10 .....	2
26	533 30 29-08	LINK, ASSY .625DIA DRAG LT 4WS .....	1
26-1	533 05 71-58	BALL JOINT 3/8 THD SMORT STUD .....	2
26-2	533 12 49-25	NUT, 3/8-24 REGHEXJAM .....	2
26-3	533 30 29-07	LINK, .625DIA DRAG LT 4WS .....	1
27	533 12 03-82	WASHER, REGSPTLK.393X.68X.10 .....	2
28	533 12 49-25	NUT, 3/8-24 REGHEXJAM .....	2
41-1	533 02 41-67	VALVE STEM	
41-2	533 32 15-16	RIM, WHEEL	
41-3	533 31 44-16	BEARING, FL	
41-4	533 30 65-69	TIRE 15X6.0X6	
44	533 30 11-40	HUB CAP, 6" EURO .....	2
45	533 30 66-69	CLIP,HUBCAP TINN #C25467-017-4 .....	8

www.emc-photo.com

D

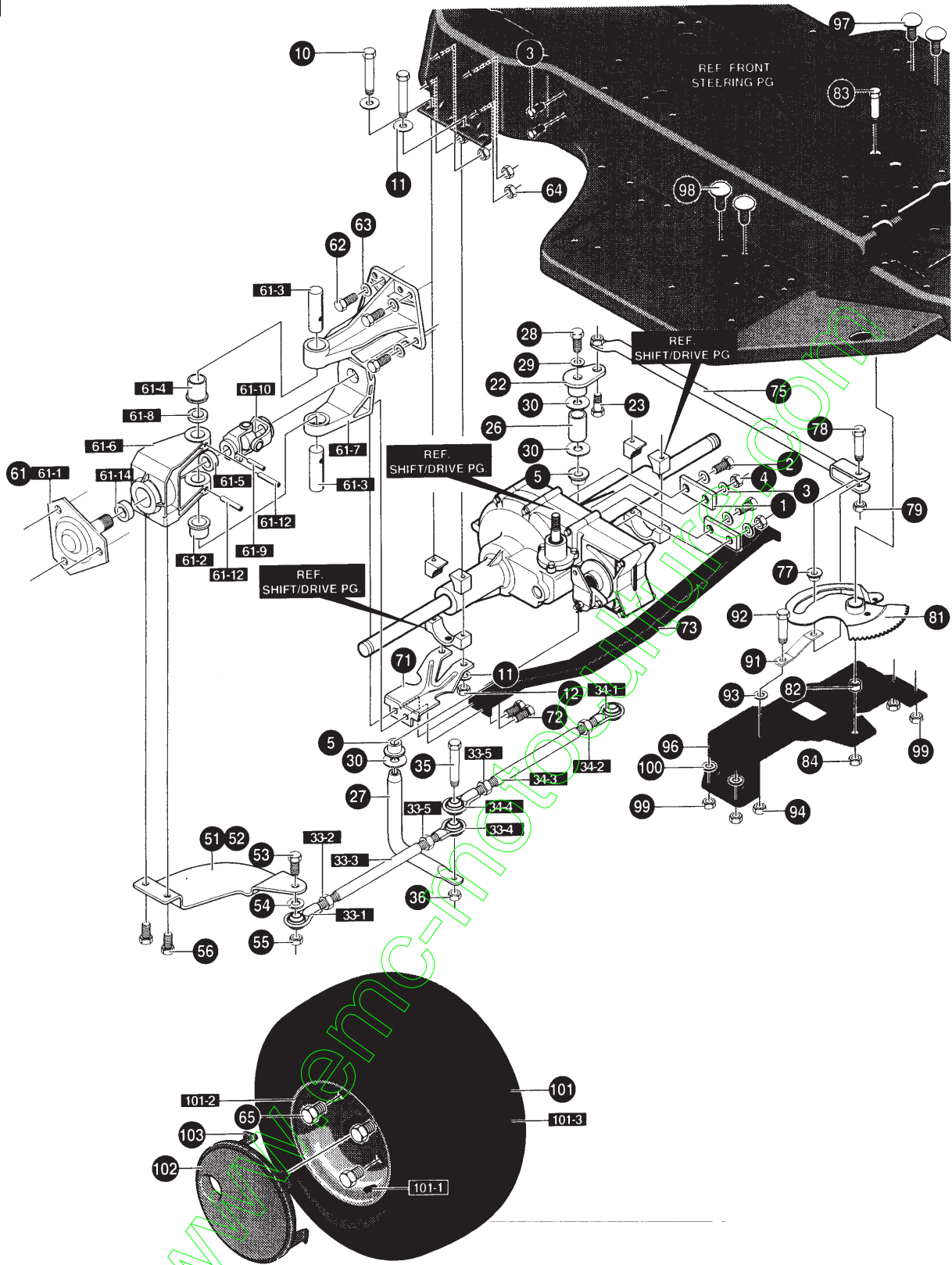





KEY#	PART#	DESCRIPTION	QTY
1	533 31 45-11	BRACKET, REAR PIVOT HYDRO.....	2
2	533 04 48-11	SCREW, 1/4-20X .75 WAHHTAP .....	2
3	533 12 03-80	WASHER, REGSPTLK.263X.49X.07 .....	4
4	533 12 03-75	NUT, 1/4-20 REGHEX.....	2
5	533 30 23-03	BEARING SPINDLE FR W/HOLE .....	2
10	874 78 05-44	SCREW, 5/16-18X2.50 HHC .....	4
11	533 12 03-93	WASHER, FLAT .344X .69X.065 .....	8
12	533 04 41-08	NUT, 5/16-18 HWDFLCTRLK .....	4
22	533 30 87-19	PIVOT, STEKRING.....	1
23	533 01 23-19	BOLT, .562X .340 HSSH 3/824 .....	1
26	533 31 36-41	SPACER, STEKRING SHAFT HYDRO.....	1
27	533 31 36-49	SHAFT, STEKRING PIVOT HYDRO.....	1
28	533 42 10-51	SCREW, 5/16-24X1.00 HHC .....	1
29	533 04 56-02	WASHER, FLAT .333X .87X.119 .....	1
30	533 02 51-77	WASHER, FLAT .765X1.19X.048 .....	3
33-1	533 30 83-84	BALL JOINT LH 3/8-24 .....	1
33-2	533 12 49-25	NUT, 3/8-24 REGHEXJAM .....	1
33-3	533 31 36-42	ROD, TIE 1/2-D X 6.75LG.....	1
33-4	533 30 42-60	BALL JOINT,RH 3/8-24.....	1
33-5	533 30 83-99	NUT, 3/8-24 LH THD REGHJAM .....	1
34-1	533 30 83-84	BALL JOINT LH 3/8-24 .....	1
34-2	533 12 49-25	NUT, 3/8-24 REGHEXJAM .....	1
34-3	533 31 36-43	ROD, TIE 1/2"D X 10.91LG ZINC.....	1
34-4	533 30 42-60	BALL JOINT,RH 3/8-24.....	1
34-5	533 30 83-99	NUT, 3/8-24 LH THD REGHJAM .....	1
35	533 18 16-46	SCREW, 3/8-24X1.75 HHC .....	1
36	533 41 23-49	NUT, 3/8-24 HXCTRLK .....	1
51	533 30 41-20	ARM REAR WHL STR (FER) R.H .....	1
52	533 30 41-21	ARM, REAR WHEEL STEER L.H.....	1
53	874 61 06-24	SCREW, 3/8-24X1.25 HHC .....	2
54	533 12 03-82	WASHER, REGSPTLK.393X.68X.10 .....	2
55	533 41 23-49	NUT, 3/8-24 HXCTRLK .....	2
56	874 78 06-16	SCREW, 3/8-16X1.00 WAHHTAP BLK .....	4
61	533 32 37-36	U-JOINT, 4-WS HEAVY DUTY.....	2
61-1	533 31 52-64	HUB ASSEMBLY HEAVY .....	1
61-2	533 01 22-88	BEARING, FLSH .752 ID X .937 OD X .75.....	1
61-3	533 01 22-89	PIN, STEKRING HINGE.....	2
61-4	533 01 23-21	BEARING, FLSH .....	1
61-5	533 01 23-25	BEARING, BALL 6203-2AA-3/4.....	1
61-6	533 31 52-67	BRACKET, STR PIVOT 6204 BEARING.....	1
61-7	533 01 24-66	BRACKET, STR PIVOT .....	1
61-8	533 02 16-82	WASHER, FLAT .765 X 1.25 X .042 .....	1
61-9	533 03 63-11	PIN, GRODVED .250 DIA X 1.50LG .....	1
61-10	533 32 05-31	U-JOINT ASSEMBLY W/ZERK (LONG).....	2
61-12	533 45 67-22	PIN, SPRING .250 DIA X 1.50LG HVPL.....	2
61-14	533 31 52-68	BEARING, BALL 6204-2AA-7/8.....	1
62	533 18 00-79	SCREW, 5/16-18X1.00 HHC .....	8
63	533 12 03-93	WASHER, FLAT .344X .69X.065 .....	8
64	533 00 14-98	NUT, 5/16-18 REGHEXCTRLK .....	8
65	533 18 16-83	SCREW, 1/2-20X .50 HHC .....	6
71	533 31 36-45	BRKT X-AXLE MTG 4WS HYDRO.....	2
72	533 03 54-98	SCREW, 5/16-18X .75 WAHHTAP.....	4
73	533 32 29-59	BRACKET HYDRO 4WS SUPPORT.....	1
75	533 31 36-39	ROD R WHL STR 4WS(HYDRO) .....	1
77	533 30 41-16	CAM YOKE ROLLER .....	1
78	533 30 41-22	BOLT, .625 X1.175HSSH .....	1
79	533 27 46-54	NUT, 1/2-20 REGHXCTRLK .....	1
81	533 30 28-77	ASSY SECTOR GEAR 4WS.....	1
82	533 30 28-78	BRNG, SLEV . IDX . ODX.....	1
83	533 18 17-09	SCREW, 1/2-20X2.50 HHC .....	1
84	533 27 46-54	NUT, 1/2-20 REGHXCTRLK .....	1
91	533 30 25-94	FOLLOWER,ROLLER.....	1
92	533 30 25-88	BOLT, .265X .800 HSSH 3/824 .....	1
93	533 44 63-63	WASHER, FLAT .375X .88X.082 .....	1
94	533 41 23-49	NUT, 3/8-24 HXCTRLK.....	1
96	533 30 25-83	PLATE, PIVOT STEKRING EURO.....	1
97	533 03 54-97	SCREW, 5/16-18X .50 WAHHTAP .....	2
98	533 03 54-98	SCREW, 5/16-18X .75 WAHHTAP .....	2
99	533 00 14-98	NUT, 5/16-18 REGHEXCTRLK .....	4
100	533 44 63-63	WASHER, FLAT .375X .88X.082 .....	2
101	533 30 42-59	TIRE & RIM,20X10.00-8 WHITE .....	2
101-1	533 02 41-67	VALVE STEM .....	
101-2	533 31 66-67	RIM,WHEEL .....	
102	533 30 65-70	HUB CAP, 8~ EURO.....	2
103	533 30 66-69	CLIP,HUBCAP TINN #C25467-017-4 .....	10

E

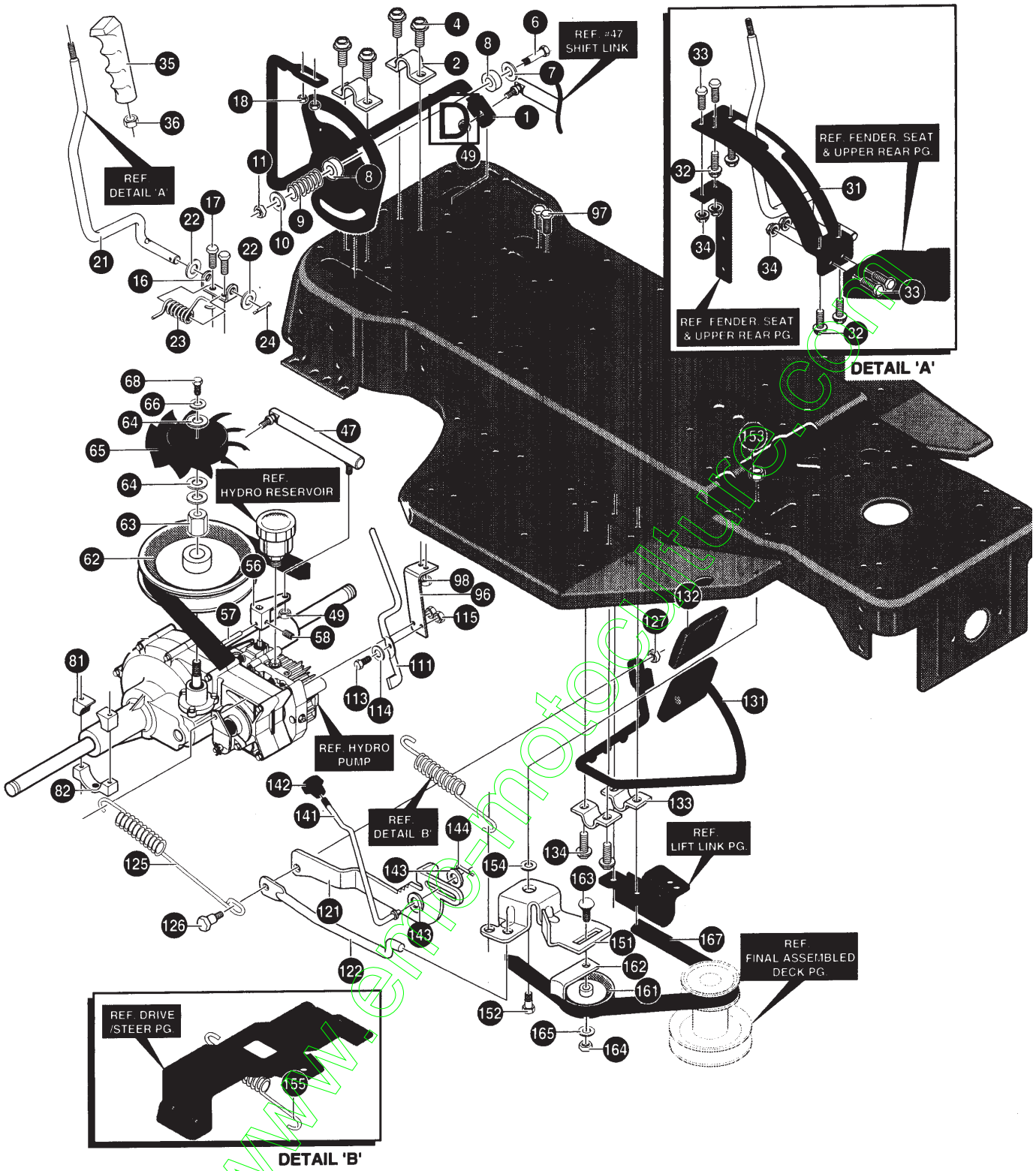

KEY #	PART #	DESCRIPTION	QTY.
1	533 31 02-06	SHIFT ROD, ASSY.....	1
2	533 31 32-71	BRACKET CUBR ARM.....	2
4	533 03 54-97	SCREW, 5/16-18X .50 WAHTAP.....	4
6	874 76 05-32	SCREW, 5/16-1 8X2.00 HHC.....	1
7	533 00 08-45	WASHER,FLAT .390X1.25X.119.....	1
8	533 04 99-22	WASHER, FRICTION 1.250DX.341D.....	2
9	533 02 91-70	SPRING.....	1
10	533 12 03-93	WASHER, FLAT .344X .69X.065.....	1
11	533 00 14-98	NUT, 5/16-18 REGHEXCTRLK.....	1
16	533 31 03-56	BRACKET, PIVOT SHIFT LEVER.....	1
17	874 76 04-12	SCREW, 1/4-20X .75 HHC.....	2
18	873 68 04-00	NUT, 1/4-20 WDFL MAGLOCK.....	2
21	533 32 69-25	ROD SHIFT.....	1
22	533 07 10-73	WASHER, FLAT .469X .92X.065Y.....	5
23	533 31 03-36	SPRING-TORSION HYDRO SHIFT.....	1
24	533 12 12-22	PIN, COTTER .090 DIA X .75LG.....	1
31	533 31 02-63	QUADRANT SHIFT HYDRO.....	1
32	533 30 03-02	SCREW, #10 X .50 HHTAPPST.....	4
33	874 76 04-12	SCREW, 1/4-20X .75 HHC.....	4
34	533 05 13-35	NUT, 1/4-20 WDFLWHIZ-LK.....	4
35	533 30 47-29	HANDLE, 1/2-13 MOLDED.....	1
36	533 12 02-38	NUT, 1/2-13 HEXJAM.....	1
47	533 32 49-36	SHIFT LINK ASS'Y .625DIA.....	1
49	533 41 23-49	NUT, 3/8-24 HXCTRLK.....	2
56	533 31 01-80	ARM SPEED CONTROL HYDRO.....	1
57	533 45 66-52	PIN, SPRING.187DIA X .88LG HVPL.....	1
58	533 10 25-70	SCREW, 1/4-20X.38NYLALHSETCPPT.....	1
62	533 31 00-98	PULLEY ASSY HYDRO.....	1
63	533 31 00-94	NUT PULLEY 1/2-20 AND 1/4-20.....	1
64	734 11 65-41	WASHER, FLAT .281X1.25X.06.....	3
65	533 30 85-23	FAN, HYDRO 7.00DIA 10 BLADES.....	1
66	533 12 03-80	WASHER, REGSPTLK.263X.49X.07.....	1
68	874 76 04-12	SCREW, 1/4-20X .75 HHC.....	1
81	533 31 08-13	MOUNTING BLOCK LH HYDRO.....	4
82	533 31 01-87	MOUNTING BLOCKS HYDRO.....	2
96	533 31 01-79	STABILIZER BRACKET.....	1
97	533 18 00-77	SCREW, 5/16-18X .75 HHC.....	2
98	533 00 14-98	NUT, 5/16-18 REGHEXCTRLK.....	3
111	533 31 02-61	ROD-RELIEF VALVE.....	1
113	533 31 00-88	BOLT, .250X .312 H HSH 1/420.....	1
114	533 00 24-83	WASHER, .391DX1.25DX.07BELLVIL.....	1
115	533 00 14-98	NUT, 5/16-18 REGHEXCTRLK.....	1
121	533 31 02-60	LEVER PARK BRAKE.....	1
122	533 31 47-38	ROD CLUTCH.....	1
125	533 32 50-09	SPRING, BRAKEHGHYDRO (EURO).....	1
126	533 31 00-87	BOLT, .500X .500 HHS 5/16-18.....	1
127	533 00 14-98	NUT, 5/16-18 REGHEXCTRLK.....	1
131	533 31 02-57	ASSY, WELD CL/BR ROD.....	1
132	533 30 23-35	PAD, CLUTCH/BRAKE MOLD W/L.....	1
133	533 31 32-71	BRACKET CUBR ARM.....	2
134	533 03 54-97	SCREW, 5/16-18X .50 WAHTAP.....	2
141	533 30 42-17	ROD, PARKING BRAKE.....	1
142	533 30 43-67	KNOB, PARK BRAKE.....	1
143	533 12 03-85	WASHER, FLAT .250X .56X.049.....	2
144	533 12 12-23	PIN, COTTER .062 DIA X .75LG.....	1
151	533 31 47-86	ARM IDLER.....	1
152	533 31 02-69	BOLT, .621X .143 HHS 5/16-18.....	1
153	533 00 14-98	NUT, 5/16-18 REGHEXCTRLK.....	1
154	533 04 56-02	WASHER, FLAT .333X .87X.119.....	1
155	533 31 36-60	SPRING, CLUTCH.113X.750X6.88.....	1
161	533 30 30-31	PULLEY, IDLER V4L 3.12EFF DIA.....	1
162	533 03 96-59	RETAINER, BELT.....	1
163	533 04 58-92	BOLT, 3/8-16X1.50 CARR.....	1
164	533 12 03-77	NUT, 3/8-16 REGHX.....	1
165	533 12 03-82	WASHER, REGSPTLK.393X.68X.10.....	1
167	533 31 02-75	BELT, V 4L 82.5 HYDRO TRACTION.....	1

F

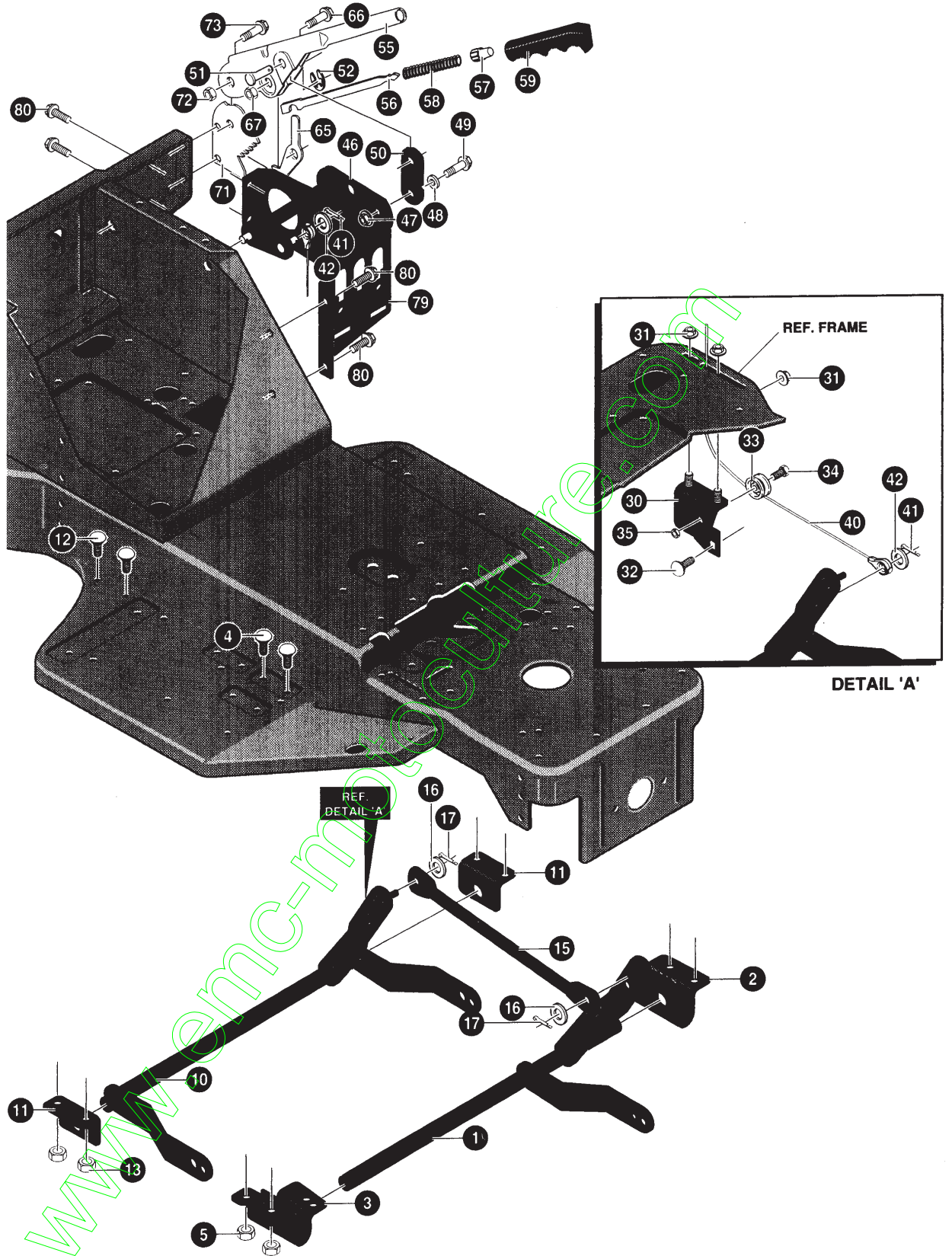



KEY #	PART #	DESCRIPTION	QTY.
1	533 30 23-79	SHAFT, ASSY FRONT LIFT EURO .....	1
2	533 30 49-67	BRACKET, FRONT HANGER RH .....	1
3	533 30 23-38	BRACKET, FRONT HANGER LH .....	1
4	533 18 00-77	SCREW, 5/16-18X .75 HHC .....	4
5	533 00 14-98	NUT, 5/16-18 REGHEXCTRLK .....	4
10	533 30 92-13	SHAFT,ASSY REARLIFT E/C EUR.....	1
11	533 30 23-60	BRACKET, REAR HANGER EURO .....	2
12	533 18 00-77	SCREW, 5/16-18X .75 HHC .....	4
13	533 00 14-98	NUT, 5/16-18 REGHEXCTRLK .....	4
15	533 30 23-80	TIE ROD .....	1
16	533 12 03-94	WASHER, FLAT .406X .81X.065 .....	2
17	533 12 12-22	PIN, COTTER .090 DIA X .75LG .....	2
30	533 30 32-30	ASSY,PULLEY BRKT.....	1
31	533 05 52-73	NUT, 5/16-18 HXWDFLLK .....	3
32	872 14 05-05	BOLT, 5/16-18X .63 CARRLN .....	1
33	533 04 83-06	PULLEY,POWDER METAL .....	1
34	533 30 55-22	BOLT, .375X .700 HSH 5/1618.....	1
35	533 00 14-98	NUT, 5/16-18 REGHEXCTRLK .....	1
40	533 30 32-27	CABLE,DECK LIFT .....	1
41	533 12 12-22	PIN, COTTER .090 DIA X .75LG .....	2
42	533 12 03-93	WASHER, FLAT .344X .69X.065 .....	2
46	533 30 22-05	ASSY, UPPER SHAFT.....	1
47	533 00 14-98	NUT, 5/16-18 REGHEXCTRLK .....	1
48	533 04 56-02	WASH ER, FLAT .333X .87X.119.....	1
49	533 03 61-49	BOLT, .375X .500 HSH 5/1618.....	1
50	533 30 23-57	LINK .....	1
51	533 30 03-10	PIN,CLEVIS.310DIA+.475LG.....	1
52	533 30 03-11	RING,RETE.31X.25TRUX5133-31.....	1
55	533 05 83-32	HEIGHT LEVER .....	1
56	533 05 83-30	ROD, ACTUATOR .....	1
57	533 05 83-25	KNOB, HEIGHT ADJ PUSH BUTTON.....	1
58	533 05 83-26	SPRING, HEIGHT ADJUST.....	1
59	533 30 47-30	GRIP, HAND .741DX5.15 .....	1
65	533 30 12-39	PAWL, SQUARE .....	1
66	533 30 01-71	BOLT, .500X .270 HSH 5/1618.....	1
67	533 04 41-08	NUT, 5/16-18 HWDFLCTRLK .....	1
71	533 30 23-83	QUADRANT .....	1
72	533 00 14-98	NUT, 5/16-18 REGHEXCTRLK .....	1
73	533 30 01-71	BOLT, .500X .270 HSH 5/1618.....	1
79	533 30 22-08	BRACKET, SUPPORT ENGAGE .....	1
80	533 03 54-97	SCREW, 5/16-18X .50 WAHTAP .....	4

www.emc.com



G

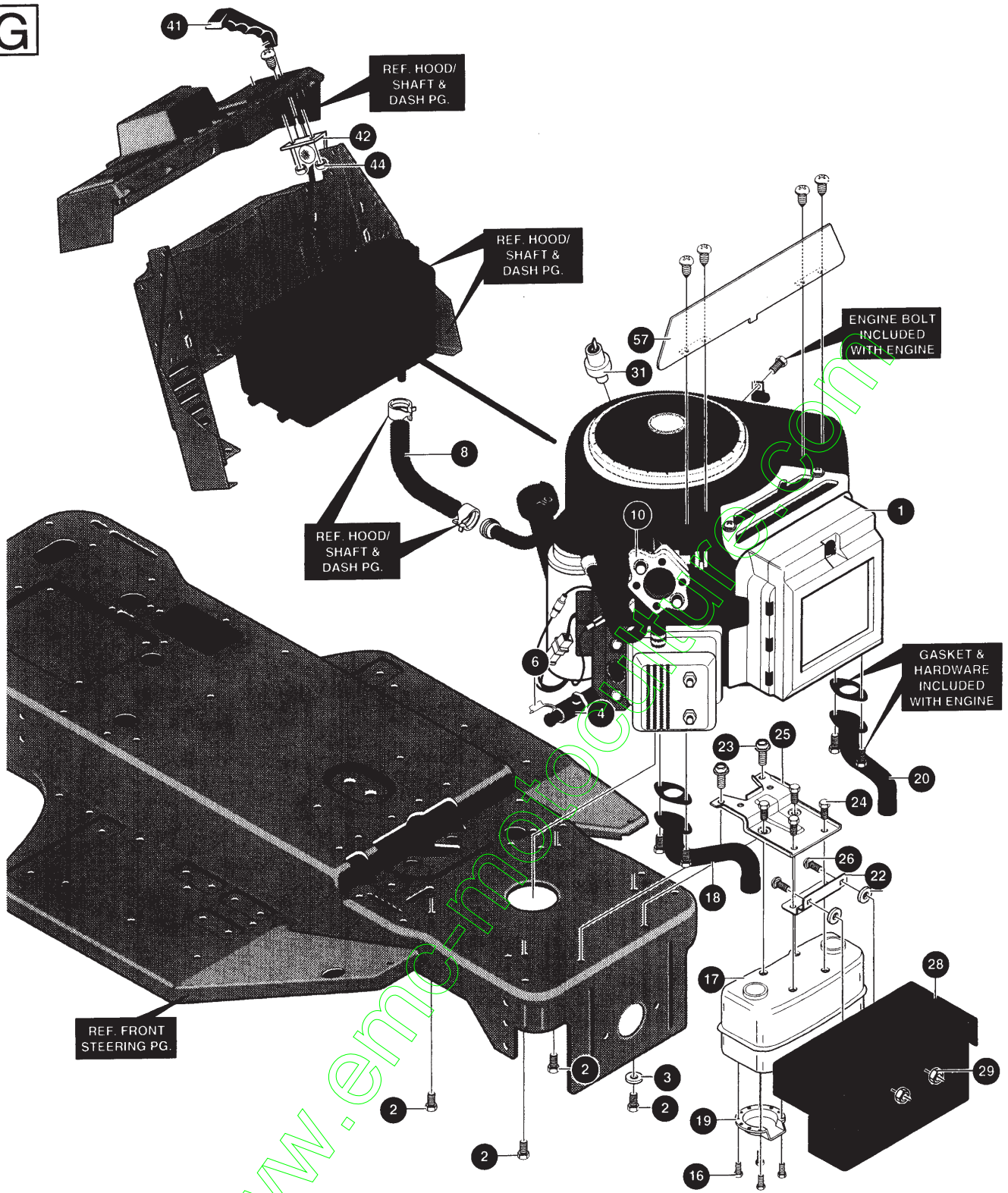

KEY #	PART #	DESCRIPTION	QTY.
1	ENGINE	.....	1
2	533 05 09-47	SCREW, 3/8-16X1.25 WAHHTAPBLKP.....	4
3	533 13 84-89	WASHER, EXLK .384X.69X.04.....	1
4	533 30 71-74	NIPPLE 3/8-18 NPT X 4. ZINC.....	1
6	533 04 78-28	CAP, PIPE 3/8-18 NPT ZN PL.....	1
8	506 66 42-01	TUBING, .25X.50X BULK GAS LINE.....	10 IN.
10	533 31 55-99	REGULATOR,VOLTAGE BS W/O SENSOR.....	1
16	533 00 52-87	SCREW, #8-32X .38 HHWATAP.....	4
17	533 30 55-53	MUFFLR 14/18TWIN NLSN 22785C...	1
18	533 30 55-54	EXHAUST TUBE 15HP RH BOS VANG	1
19	533 05 64-72	DEFLECTOR SIDE OUT (BS222573)	1
20	533 30 55-55	EXHAUST TUBE 15HP LH B&S VANG	1
22	533 00 97-96	BRACKET, TRANSAXLE.....	1
23	533 03 54-97	SCREW, 5/16-18X .50 WAHHTAP.....	2
24	533 04 48-11	SCREW, 1/4-20X .75 WAHHTAP.....	4
25	533 30 47-09	BRACKET, MUFFLER.....	1
26	872 11 05-06	BOLT, 5/16-18X .63 CARRLN.....	2
28	533 32 09-22	SHIELD, MUFFLER HEAT TWIN.....	1
29	533 05 52-73	NUT, 5/16-18 HXWDFLLK.....	2
31	533 31 47-97	OIL SENSOR, BOS TWIN CYL.....	1
41	533 30 44-39	KNOB, THROTTLE CTL MOLD.....	1
42	533 30 73-62	THROTTLE CONTROL ERO 18 TWIN	1
44	533 30 84-59	NUT, #10-24 HXHDNYLK.....	2
57	533 32 13-06	HEAT SHIELD V/G LT EURO.....	1

www.emc-motoculture.com

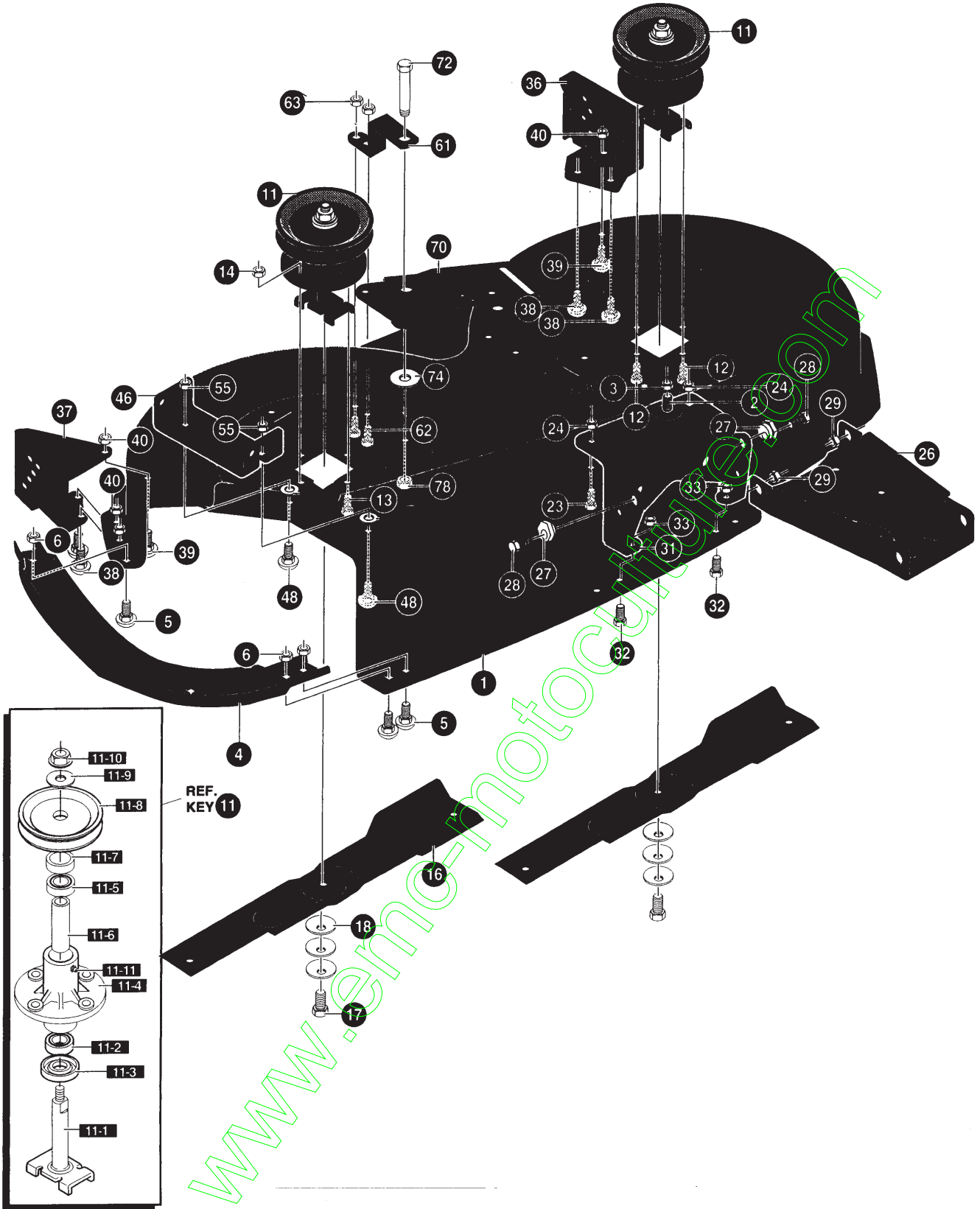



KEY #	PART #	DESCRIPTION	QTY.
1	533 32 51-03	MOWER DECK KIT 40~ LF/EURO.....	1
2	533 18 00-77	SCREW, 5/16-18X .75 HHC.....	1
3	533 00 14-98	NUT, 5/16-18 REGHEXCTRLK.....	1
4	533 32 64-80	TOK GUARD - MULCHER.....	1
5	872 11 05-06	BOLT, 5/16-18X .63 CARRLN.....	3
6	533 00 14-98	NUT, 5/16-18 REGHEXCTRLK.....	3
11	533 31 77-05	QUILL 36/40/43 W/ZERKS.....	2
12	533 03 54-98	SCREW, 5/16-18X .75 WAHHTAP.....	7
13	533 30 03-45	SCREW, 5/16-18X1.38 WAHHTAP.....	1
14	533 00 14-98	NUT, 5/16-18 REGHEXCTRLK.....	4
16	533 31 33-16	BLADE, 40H STD-LIFT 20.32.....	2
16	533 30 90-70	BLADE, 40" HI-LIFT 20.32.....	2
17	533 03 95-73	SCREW, 3/8-24X1.00 NYLHHC.....	2
18	533 00 24-83	WASHER, .391DX1.25DX.07 BELLVIL.....	6
23	872 11 05-06	BOLT, 5/16-18X .63 CARRLN.....	2
24	533 00 14-98	NUT, 5/16-18 REGHEXCTRLK.....	2
26	533 31 08-00	CHANNEL DRAWBAR 40 EURO.....	1
27	533 05 82-47	NUT, ADJUST.....	2
28	533 18 00-79	SCREW, 5/16-18X1.00 HHC.....	2
29	533 00 14-98	NUT, 5/16-18 REGHEXCTRLK.....	2
31	533 31 23-42	BRACKET FRONT.....	1
32	533 18 00-77	SCREW, 5/16-18X .75 HHC.....	2
33	533 00 14-98	NUT, 5/16-18 REGHEXCTRLK.....	2
36	533 31 70-41	BRACKET,GAGEWHEEL L.H.....	1
37	533 31 70-18	BRACKET, GUAGE WHEEL RH.....	1
38	533 18 00-77	SCREW, 5/16-18X .75 HHC.....	4
39	872 11 05-06	BOLT, 5/16-18X .63 CARRLN.....	2
40	533 00 14-98	NUT, 5/16-18 REGHEXCTRLK.....	6
46	533 31 70-17	BRACKET CHUTE MOUNT.....	1
48	872 11 05-06	BOLT, 5/16-18X .63 CARR.....	2
55	533 00 14-98	NUT, 5/16-18 REGHEXCTRLK.....	2
61	533 32 68-93	BRACE IDLER SUPPORT 40n,43~.....	1
62	533 18 00-77	SCREW, 5/16-18X .75 HHC.....	2
63	533 04 41-08	NUT, 5/16-18 HWDFLCTRLK.....	2
70	533 32 21-17	IDLER ARM40/43/46 DECK.....	1
72	533 30 44-20	BOLT, .500X2.15 HHSH.....	1
74	734 11 78-01	WASHER, FLAT, .391X1.00X.209.....	1
78	873 22 06-00	NUT, 3/8-16 HWDFLLK MACK.....	1

www.emc-parts.com

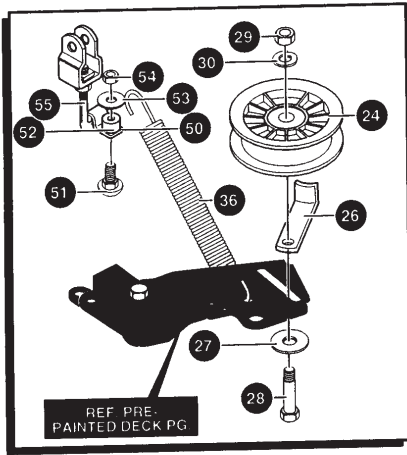

DETAIL 'A'

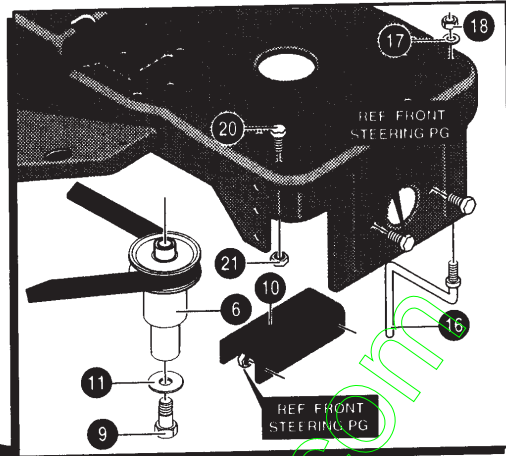

REF LIFT LINK PG

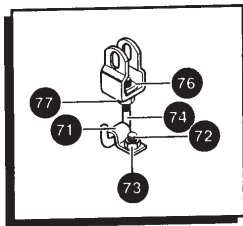

REF KEY 75

REF DETAIL A

REF DETAIL A

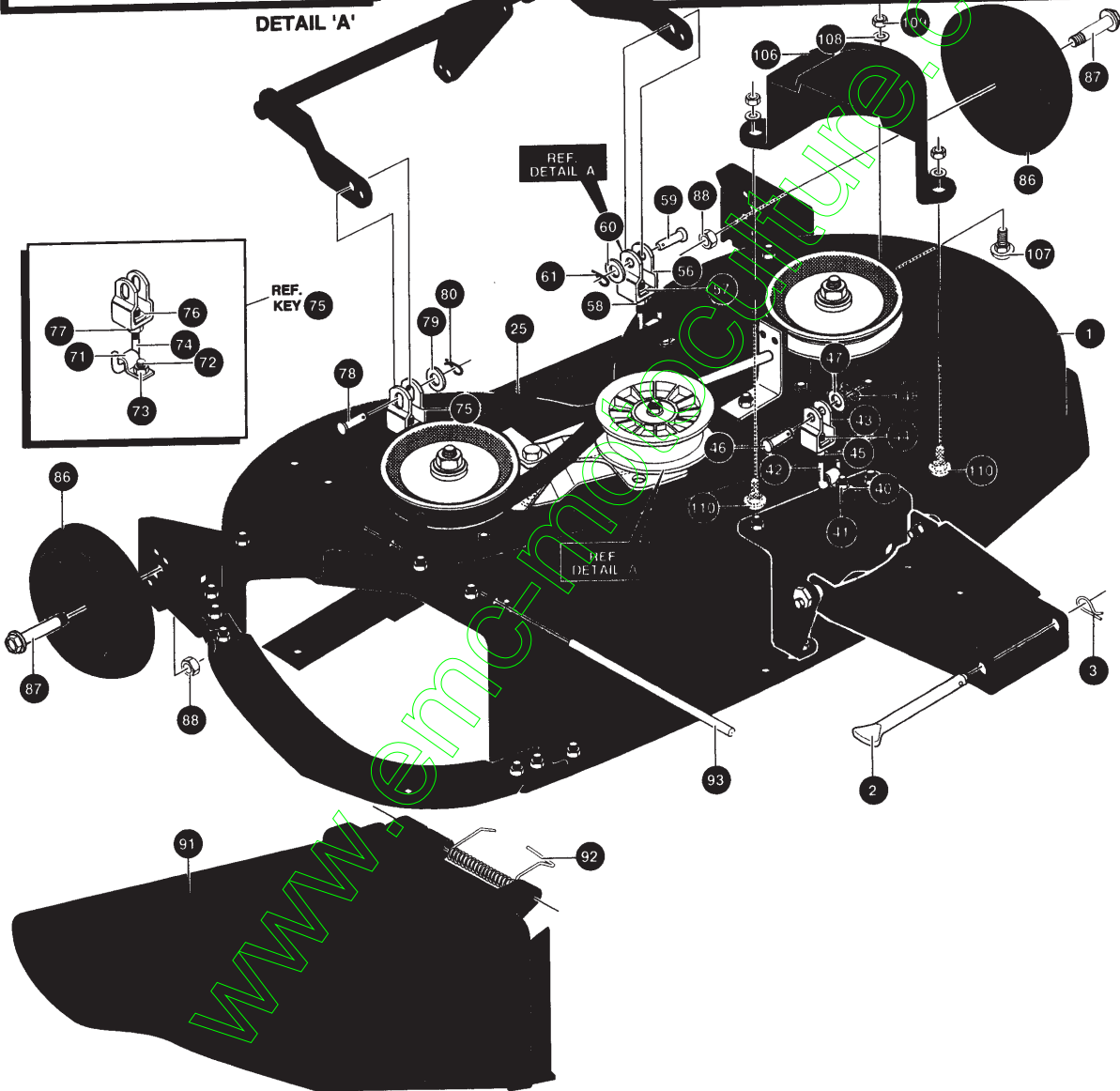

www.Eng-Tech.com



KEY #	PART #	DESCRIPTION	QTY.
1	533 32 80-51	40 DECK EC,LL,ZERKS,W/O-ROLL	1
2	533 30 29-63	ROD, DRAWBAR	1
3	533 05 61-80	PIN, HAIR .091 DIA X 1.62 LG	1
6	533 33 23-51	PULLEY, ENGINE EUCL EURO LT	1
10	533 30 90-11	BRACKET, CLUTCH STOP 40/46 E/C	1
16	533 30 04-40	BELT GUIDE	1
17	533 13 85-38	WASHER, REGINTLK.320X.61 X.03	1
18	533 00 14-98	NUT, 5/16-18 REGHEXCTRLK	1
20	533 18 00-77	SCREW, 5/16-18X .75	1
21	533 00 14-98	NUT, 5/16-18 REGHEXCTRLK	1
24	533 31 03-26	PULLEY, IDLER BFF 4.00 WIDE	1
25	533 30 51-48	BELT, V 5L 83.0 40~ DECK	1
26	533 00 13-46	RETAINER, BELT	1
27	533 44 63-63	WASHER, FLAT .375X .88X.082	1
28	533 05 73-25	BOLT, 3/8-16X2.00 CARR	1
29	533 12 03-77	NUT, 3/8-16 REGHEX	1
30	533 12 03-82	WASHER REGSPTLK.393X.68X.10	1
36	533 32 93-64	SPRING,IO&43~ (12 TO 20 HP EC)	1
40	533 31 98-68	CLIP, 40/46 HANGER	1
41	533 00 14-98	NUT, 5/16-18 REGHEXCTRLK	1
42	533 30 96-15	ROD, 40. REAR DECK LIFT	1
43	533 30 44-43	CLEVIS	1
44	533 10 95-27	NUT, 1/2-13 .458 SQ	1
45	533 12 02-38	NUT, 1/2-13 HEXJAM	1
46	533 00 03-17	PIN, CLEVIS.375DIA.X.81LG	1
47	533 12 03-94	WASHER, FLAT .406X .81X.065	1
48	533 05 61-80	PIN, HAIR .091 DIA X 1.62 LG	1
50	533 31 98-68	CLIP, 40/46 HANGER	1
51	872 11 05-08	CARR. BOLT, 5/16-18X1.00	1
52	533 05 05-20	SPACER	1
53	734 11 63-01	FLATWASHER, .328X1.06X.062	1
54	533 00 14-98	NUT, 5/16-18 REGHEXCTRLK	1
55	533 31 23-02	ROD, 40. REAR DECK LIFT	1
56	533 30 44-43	CLEVIS	1
57	533 10 95-27	NUT, 1/2-13 .458 SQ	1
58	533 12 02-38	NUT, 1/2-13 HEXJAM	1
59	533 30 03-17	PIN, CLEVIS .375DIA.X .81 LG	1
60	533 12 03-94	FLATWASHER, .406X .81 X.065	1
61	533 05 61-80	PIN, HAIR .091 DIA X 1.62 LG	1
71	533 31 98-68	CLIP, 40/46 HANGER	1
72	533 18 00-77	SCREW, 5/16-18X .75 HHC	1
73	533 00 14-98	NUT, 5/16-18 REGHEXCTRLK	1
74	533 30 96-15	ROD, 40H REAR DECK LIFT	1
75	533 30 52-83	CLEVIS, SLOT EURO	1
76	533 10 95-27	NUT, 1/2-13 .458 SQ	1
77	533 12 02-38	NUT, 1/2-13 HEXJAM	1
78	533 30 03-17	PIN, CLEVIS .375DIA.X .81 LG	1
79	533 12 03-94	WASHER, FLAT .406X .81X.065	1
80	533 05 61-80	PIN, HAIR .091 DIA X 1.62 LG	1
86	533 30 26-11	GAUGE WHEEL,EURO 6.000DX1.38WD	2
87	533 02 37-63	BOLT, .500X1.390 HSH 3/8-16	2
88	533 00 14-99	NUT, 3/8-16 REGHXCTRLK	2
91	533 30 44-22	CHUTE DEFLECTOR 40H.42~&43~	1
92	533 31 49-75	SPRING,TORSION CHUTE DEFLECTOR	1
93	533 30 44-24	ROD,PIVOT DECK .31 2DX7.25	1
106	533 32 82-57	GUARD, BELT LH PLASTIC	1
107	533 18 00-77	SCREW, 5/16-18X .75 HHC	1
108	533 12 03-93	WASHER, FLAT .344X .69X.065	3
109	533 00 14-98	NUT, 5/16-18 REGHEXCTRLK	3
110	872 11 05-06	BOLT, 5/16-1 8X .63 CARR	2

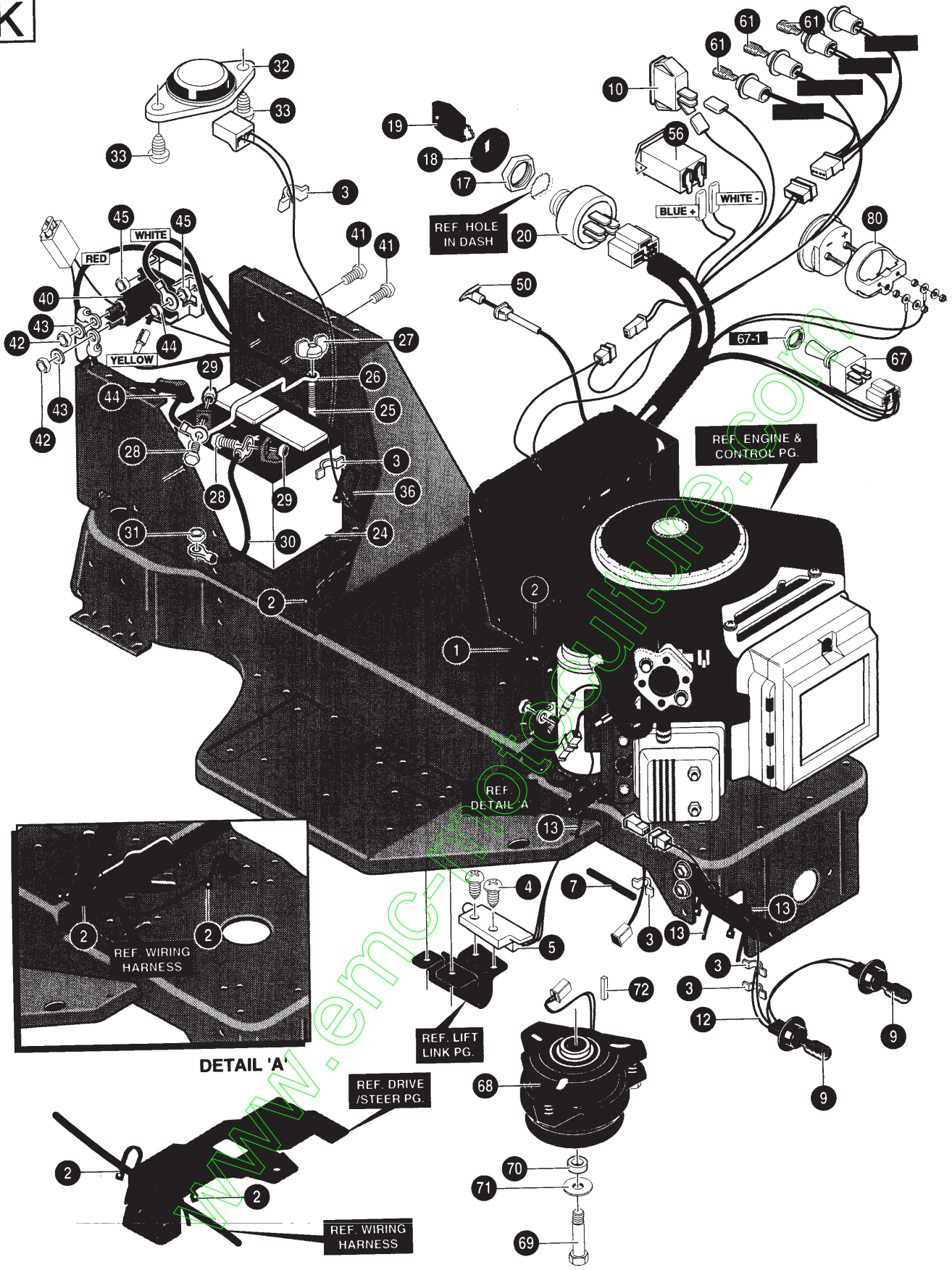

KEY #	PART #	DESCRIPTION	QTY.
1	533 33 19-31	HARNES, WIRING EURO VG/TW E/C AMP.....	1
2	533 05 74-44	TIE, CABLE BLACK NYLON 5.62L.....	6
3	533 04 14-82	PRESS CLIP, 1.380LG .2551D.....	3
4	533 05 72-20	SCREW, #12 X .50 PHPNHTAP BLK.....	2
5	533 05 74-76	SWITCH, SCR MNT DP NC NO BLK.....	1
7	533 05 21-51	EDGING, WIDE BLK.....	78"
9	533 05 25-72	BULB, HEADLAMP.....	2
10	533 30 03-34	LIGHT SWITCH ON/OFF PANEL MNT.....	1
12	533 30 30-64	ASSY, LIGHT WIRE-1/4 TURN.....	1
13	533 05 74-44	TIE, CABLE BLACK NYLON 5.62L.....	3
17	533 32 73-52	NUT, 5/8-8ACME DELTA FOR BOOT.....	1
18	533 30 01-94	BOOT, IGN SWITCH.....	1
19	533 32 73-50	KEY, IGNITION GENERIG DELTA.....	2
20	533 32 73-55	SWITCH-IGN.(AFTER FIRE) 3 POSN.....	1
24	506 78 88-01	BATTERY, 12V.....	1
25	533 05 75-51	ROD, BATTERY.....	1
26	533 30 29-12	ROD, BATTERY TOP .209DIA.....	1
27	533 32 52-32	NUT, WING 1/4-20 NYLON.....	1
28	874 76 04-12	SCREW, 1/4-20X .75 HHC.....	2
29	533 27 11-72	NUT, 1/4-20 REGHEXKEPS.....	2
30	533 05 55-11	WIRE, GROUND, 12.5~.....	1
31	533 27 11-84	NUT, 5/16-18 HEXKEPS.....	1
32	533 05 75-47	SWITCH, SKAT.....	1
33	506 55 80-01	SCREW, 1/4-20X .38PHPNHMA.....	2
36	533 05 74-44	TIE, CABLE BLACK NYLON 5.62L.....	2
40	533 31 09-66	SOLENOID STARTER - ISOLATED.....	1
41	533 18 77-45	SCREW, 1/4-20X .75 HXSEMMA.....	2
42	533 12 03-68	NUT, 5/16-24 REGHEX.....	2
43	533 13 84-85	WASHER, EXLK .320X.61X.03.....	2
44	533 27 11-72	NUT, 1/4-20 REGHEXKEPS.....	1
45	533 00 15-02	NUT, 1/4-20 REGHEXCTRLK.....	2
46	533 05 74-44	TIE, CABLE BLACK NYLON 5.62L.....	1
50	533 30 71-13	CHOKE CONT BS TWIN ERO LONG.....	1
56	506 89 15-01	MINIATURE HOUR METER 440V DC.....	1
61	533 05 77-69	BULB, INDICATOR.....	3
67	533 30 92-85	SWITCH, ELEC/CLUT ACTUATOR EURO.....	1
68	533 32 61-08	CLUTCH, EL 12/18HP REG CHARGER.....	1
69	533 21 56-49	SCREW, 7/16-20X5.50 HHCGR5BLPH.....	1
70	533 31 96-22	BRNG, FL .51, 01DX .1 00DX .56L.....	1
71	533 12 03-83	WASHER, REGSPTLK 459X.78X.12.....	1
72	533 30 55-62	KEY, SQUARE .250SQX2.12LG.....	1
80	533 31 59-02	AMMETER ASSY.....	1

www.emc.com

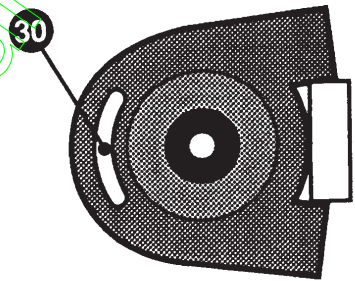
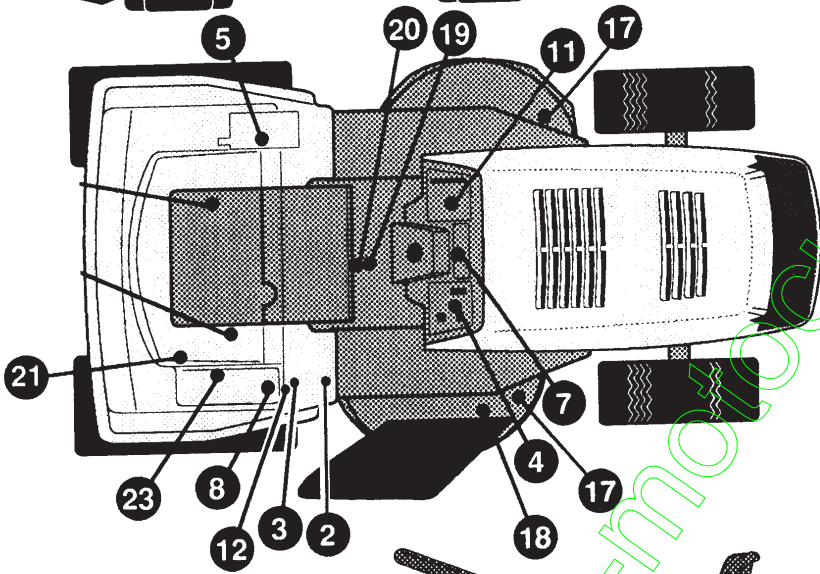
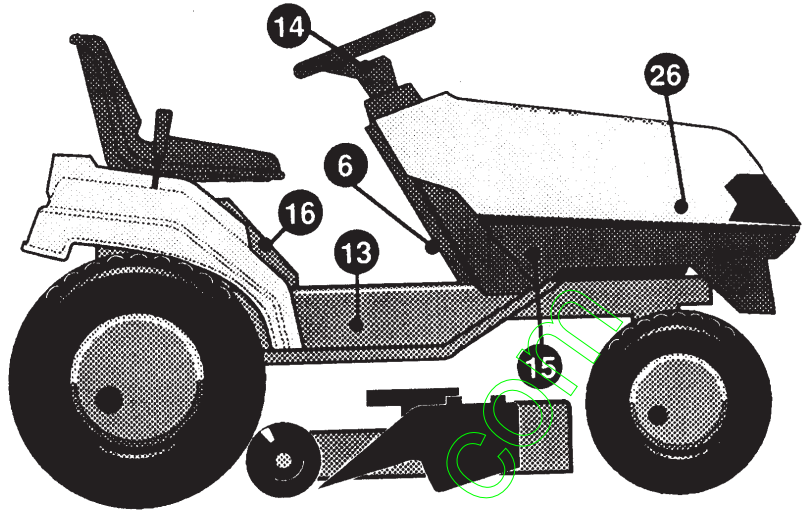
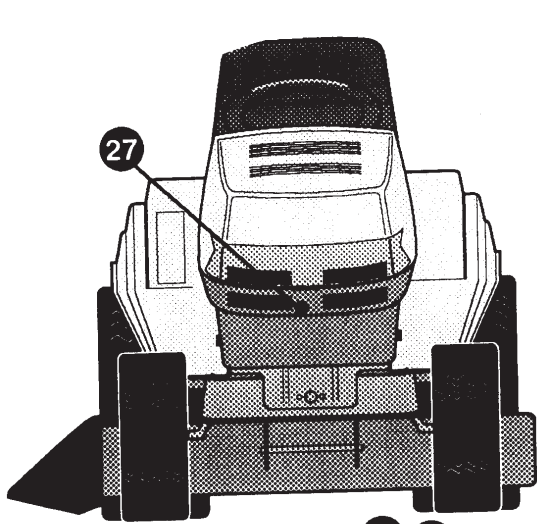

TOP OF ENGINE

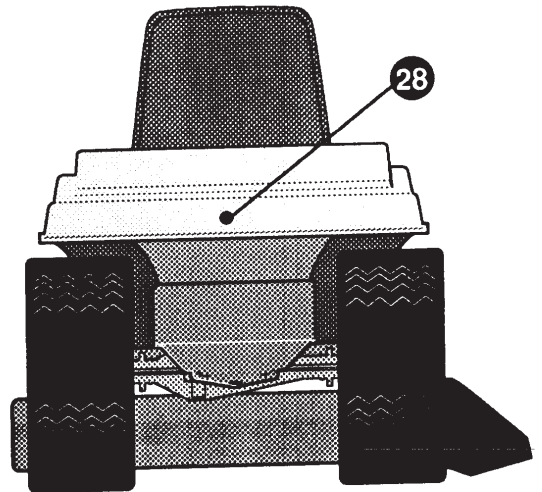
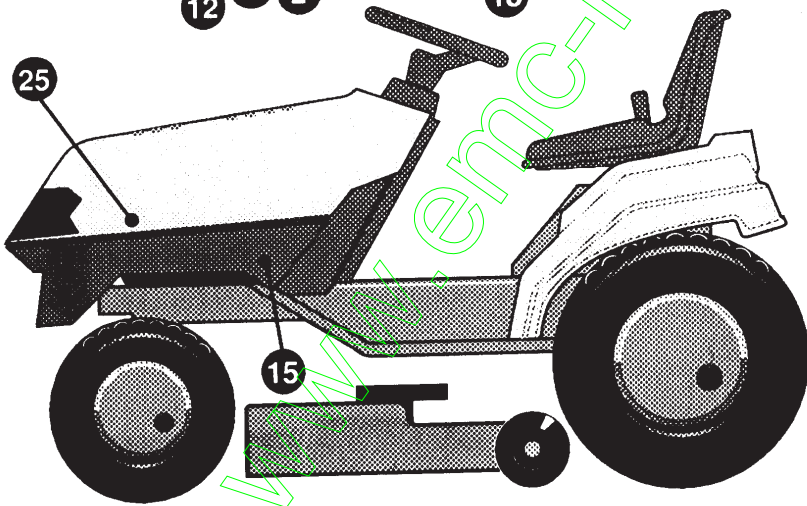





KEY #	PART #	DESCRIPTION	QTY.
2	553 30 57-70	DECAL, CAUTION TRIANGLE EUROPE .....	1
3	533 30 73-81	DECAL, DANGER FRENCH, ENGLISH.....	1
4	533 33 18-17	DECAL DASH RH ISO CH,HR,LS,IS .....	1
5	533 31 68-10	DECAL, HEIGHT E/C EXPORT .....	1
6	533 30 78-20	DECAL PARK BRAKE EXPORT .....	1
7	533 33 20-96	DECAL, DASH OIL,FUEL,ASG,NO CHG.....	1
8	533 31 35-39	DECAL, DEPRESS CUBRAKE BLACK .....	1
11	533 33 18-09	DECAL, DASH LH ISO,AMM,E/CL,M/CH.....	1
12	533 31 10-66	DECAL, DANGER GERMAN .....	1
13	533 32 28-59	DECAL, DANGER CONS SIDE SWEDISH.....	1
14	533 33 20-58	DECAL, GUNSIGHT CENT. 3 SPOKE.....	1
15	533 31 17-30	DECAL, WHEEL 4 STEER HUSQ. BUM.....	2
16	533 31 17-31	DECAL, LAWN TRACTOR SKAT SUPP.....	1
17	533 32 08-42	DECAL, WARN 11/LANG HANDS/FEET .....	2
18	533 32 08-43	DECAL, WARN DEFLECTOR SHIELD 11 LANG .....	1
19	533 32 08-44	DECAL, START INST CONS 11 LANG.....	1
20	533 32 08-45	DECAL, ENTER & EXIT 11/LANG.....	1
23	533 31 68-16	DECAL,MOTION HYDROEXPORT.....	1
25	533 32 07-15	DECAL, HOOD HUSQ. HYDRO LH.....	1
26	533 32 07-16	DECAL, HOOD HUSQ. HYDRO RH.....	1
27	533 32 21-74	DECAL, GRILLE HUSQVARNA.....	1
28	533 32 21-75	DECAL, REAR FENDER HUSQVARNA.....	1

www.emc-motoculture.com



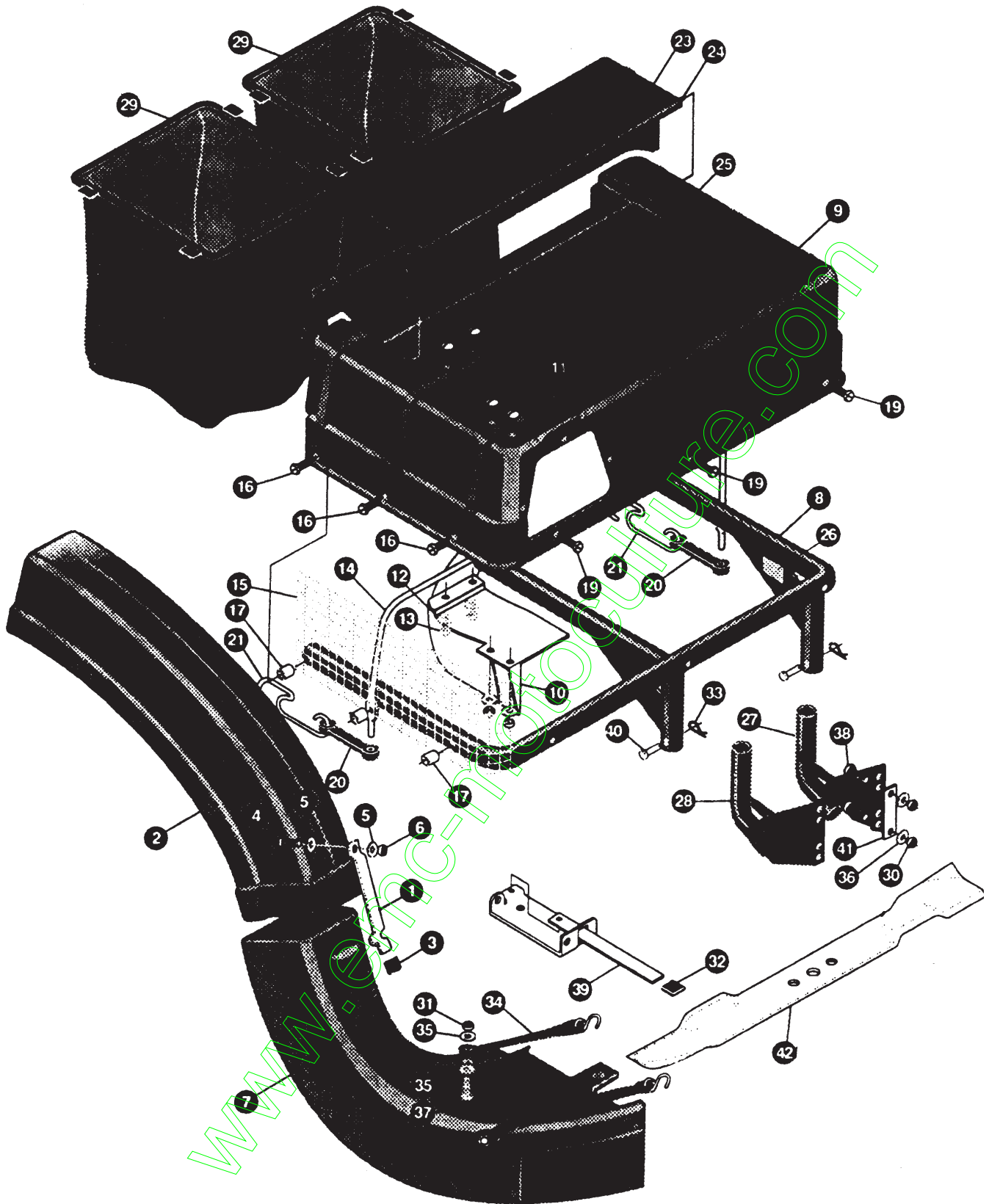



KEY#	PART#	DESCRIPTION	QTY.
1	533 32 24-94	LATCH CHUTE .....	1
2	533 32 24-95	CHUTE, UPPER 40&46 BAGGER.....	1
3	533 04 23-48	GRIP-LEVER GRASS COLLECTOR.....	1
4	533 12 18-87	SCREW 1/4-20X .75 HHC GR2.....	1
5	734 11 52-01	WASHER, FLAT .28X1.25X.06.....	2
6	533 00 15-02	NUT, 1/4 REGHEXCTRLK.....	1
7	533 31 80-73	CHUTE, LOWER 40~/43. DECK, MOD.....	1
8	533 32 29-80	WP TUBE ASSY, SUPPORT (DBL-GST) .....	1
9	533 30 92-95	TOP COVER ERO BAGGER .....	1
10	533 30 51-97	BAFFLE GRASS CATCHER EURO .....	1
11	533 05 56-86	SCREW 1/4-20X .63 SLTRMA BLK.....	4
12	533 12 03-92	WASHER, FLAT .281X .63X0.65.....	4
13	533 27 11-72	NUT, 1/4-20 REGHXEXKEPS .....	4
14	533 30 91-59	MP SUPPORT ROD, COVER.....	1
15	533 30 62-62	SCREEN ERO BAGGER 6.0X 18.25.....	1
16	533 30 64-87	SCREW, 1/4-20X1.50 HHTAP GR5 .....	3
17	533 30 60-79	SPACER, BAGGER .87X7/16X.060 .....	2
19	533 04 48-11	SCREW 1/4-20X .75 HXWATAP .....	6
20	533 05 75-05	RUBBER STRAP .....	2
21	533 30 96-48	HOLD DOWN, RUBBER STRAP .....	2
23	533 30 93-20	TOPP LID PIVIDTING .....	1
24	533 31 01-94	ROD, GRASS CATCHER PIVOT 953 .....	1
25	533 12 12-23	PIN, COTTER.0625X.75LG .....	2
27	533 32 35-55	ASSY GRASS CATCHER MT.LH.....	1
28	533 32 35-56	ASSY GRASS CATCHER MT.RH.....	1
29	533 32 21-57	BAG, GRASS CATCHER ERC (LONG).....	2
30	533 00 14-98	NUT, 5/16-18 REGHEXCTRLK .....	4
31	533 00 15-02	NUT, 1/4-20 REGHEXCTRLK.....	2
32	533 04 23-48	GRIP-LEVER GRASS COLLECTOR.....	1
33	533 05 61-80	PIN, HAIR .091 DIA X1.62LG .....	2
34	533 05 75-05	RUBBER STRAP .....	2
35	533 12 03-92	WASHER, FLAT .281X .63X.065.....	4
36	533 12 03-93	WASHER, FLAT .344X .69X.065.....	4
37	533 12 19-00	SCREW, 1/4-20X1.00 HHC GR2.....	2
38	874 78 05-16	SCREW, 5/16-18X1.00 HHC BG8.....	5
39	533 32 23-20	LEVER ASSY (SMORT) .....	1
40	533 30 86-19	PIN, CLEVIS .25X1.75 .....	2
41	533 31 51-63	BRKT. PLATE BAGGER .....	2
42	533 30 90-70	BLADE, 20.32 HIGH LIFT.....	2

www.emc-nature.com

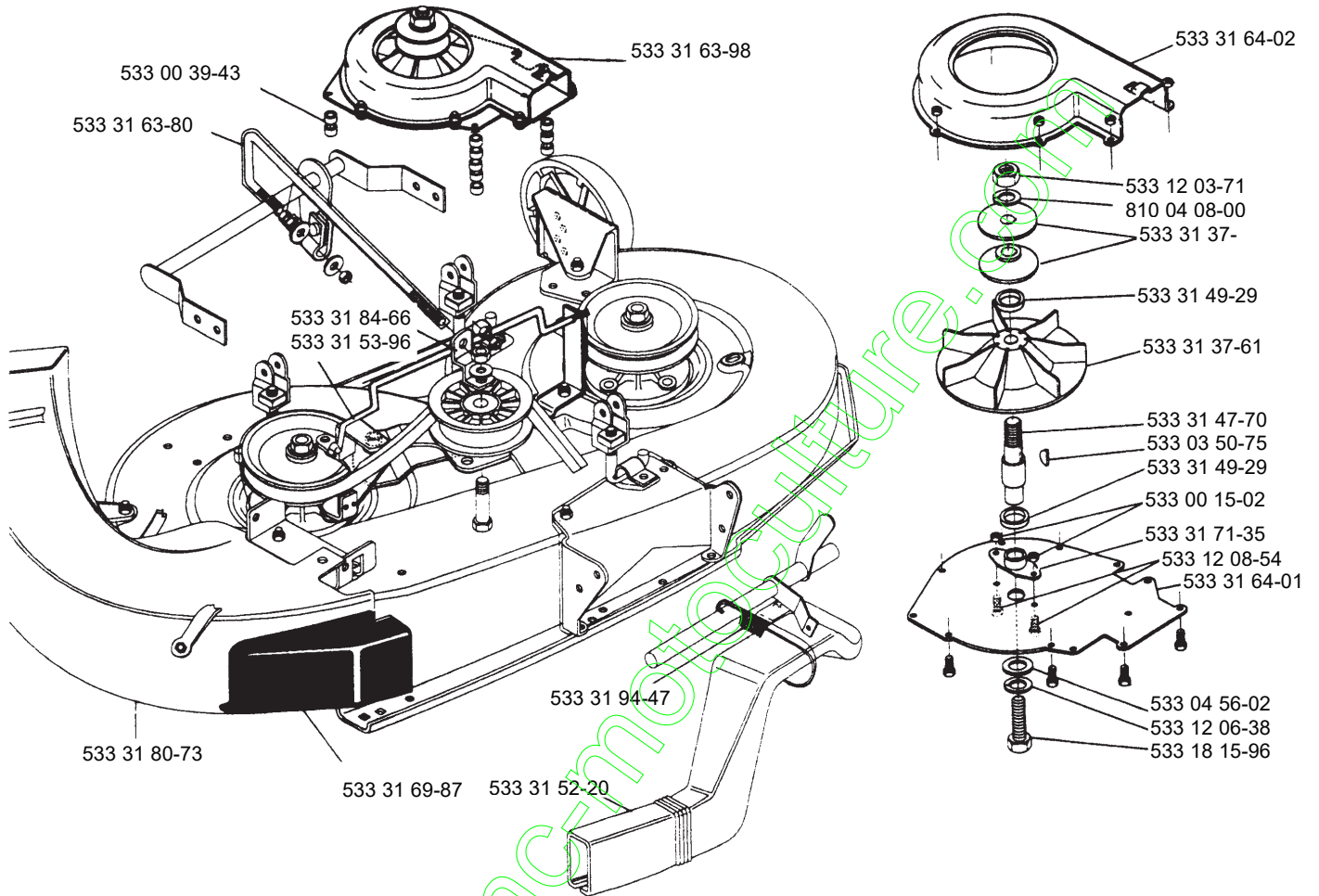

MODEL NUMBER 4140H

PART NUMBER	SQUARE	NOTE	PART NUMBER	SQUARE	NOTE	PART NUMBER	SQUARE	NOTE	PART NUMBER	SQUARE	NOTE
506 55 80-01	K		533 05 83-30	F		533 30 28-77	D		533 30 96-15	J	
506 66 42-01	G		533 05 83-32	F		533 30 28-78	D		533 31 00-87	E	
506 78 88-01	K		533 07 10-73	E		533 30 28-97	B		533 31 00-88	E	
506 89 15-01	K		533 07 11-00	A		533 30 29-07	C		533 31 00-94	E	
533 00 06-42	C		533 10 25-70	E		533 30 29-08	C	N	533 31 00-98	E	
533 00 07-06	C		533 10 95-27	J		533 30 29-12	K		533 31 01-79	E	
533 00 08-45	E		533 12 02-38	EJ		533 30 29-63	J		533 31 01-80	E	
533 00 13-46	J		533 12 03-68	K		533 30 30-31	E		533 31 01-87	E	
533 00 14-98	ABCDEFI		533 12 03-69	C		533 30 30-64	K		533 31 02-06	E	
533 00 14-99	CJ		533 12 03-75	D		533 30 32-27	F		533 31 02-57	E	
533 00 15-02	ABKM		533 12 03-77	EJ		533 30 32-28	A		533 31 02-60	E	
533 00 24-83	CEI		533 12 03-80	DE		533 30 32-30	F		533 31 02-61	E	
533 00 29-68	A		533 12 03-82	CDEJ		533 30 41-16	D		533 31 02-63	E	
533 00 97-96	G		533 12 03-83	K		533 30 41-20	D		533 31 02-69	E	
533 01 22-88	D		533 12 03-85	BE		533 30 41-21	D		533 31 02-75	E	
533 01 22-89	D		533 12 03-92	A		533 30 41-22	D		533 31 03-26	J	
533 01 23-19	D		533 12 03-93	BDEFJ		533 30 42-17	E		533 31 03-36	E	
533 01 23-21	D		533 12 03-94	FJ		533 30 42-59	D		533 31 03-56	E	
533 01 23-25	D		533 12 06-38	B		533 30 42-60	D		533 31 03-84	B	
533 01 24-66	D		533 12 12-22	EF		533 30 43-67	E		533 31 05-76	B	
533 01 25-01	A		533 12 12-23	E		533 30 44-20	I		533 31 06-70	C	
533 02 08-64	A		533 12 18-87	M		533 30 44-22	J		533 31 08-00	I	
533 02 16-82	D		533 12 49-25	CD		533 30 44-24	J		533 31 08-13	E	
533 02 37-63	J		533 13 84-85	K		533 30 44-39	G		533 31 09-66	K	
533 02 41-67	D		533 13 84-89	G		533 30 44-43	J		533 31 10-66	L	
533 02 50-86	A		533 13 85-38	J		533 30 44-81	B		533 31 17-30	L	
533 02 51-77	D		533 18 00-77	BCEFIJ		533 30 47-09	G		533 31 17-31	L	
533 02 91-70	E		533 18 00-79	DI		533 30 47-29	E		533 31 23-02	J	
533 03 52-87	G		533 18 01-34	C		533 30 47-30	F		533 31 23-42	I	
533 03 54-97	ABDEFG		533 18 16-46	D		533 30 49-67	F		533 31 32-71	E	
533 03 54-98	BDI		533 18 16-83	D		533 30 51-48	J		533 31 33-16	I	
533 03 61-49	F		533 18 17-09	D		533 30 52-80	C		533 31 35-39	L	
533 03 63-11	D		533 18 77-45	K		533 30 52-83	J		533 31 36-39	D	
533 03 63-68	B		533 21 56-49	K	N	533 30 53-39	C		533 31 36-41	D	
533 03 66-25	C		533 27 11-72	K		533 30 53-40	C		533 31 36-42	D	
533 03 95-73	I		533 27 11-84	K		533 30 53-81	B		533 31 36-43	D	
533 03 96-59	E		533 27 46-54	D		533 30 54-24	B		533 31 36-45	D	
533 04 14-82	K		533 30 01-71	F		533 30 55-20	B		533 31 36-49	D	
533 04 23-48	M		533 30 01-94	K		533 30 55-22	F		533 31 36-60	E	
533 04 41-08	DFI		533 30 03-02	AE		533 30 55-53	G		533 31 44-16	C	
533 04 48-11	BDG		533 30 03-03	A		533 30 55-54	G		533 31 45-11	D	
533 04 52-63	A		533 30 03-10	F		533 30 55-55	G		533 31 47-38	E	
533 04 56-02	DEF		533 30 03-11	F		533 30 55-62	K		533 31 47-86	E	
533 04 58-92	E		533 30 03-17	J		533 30 57-70	L		533 31 47-97	G	
533 04 78-28	G		533 30 03-28	C		533 30 58-20	A		533 31 48-88	B	
533 04 83-06	F		533 30 03-34	K		533 30 58-50	A		533 31 48-89	B	
533 04 99-22	E		533 30 03-45	I		533 30 63-97	B		533 31 49-75	J	
533 05 09-47	G		533 30 04-40	J		533 30 63-99	B		533 31 52-64	D	
533 05 13-35	BE		533 30 11-40	C		533 30 65-69	C		533 31 52-67	D	
533 05 21-51	AK		533 30 12-39	F		533 30 65-70	D		533 31 52-68	D	
533 05 25-72	K		533 30 22-05	F		533 30 66-69	CD		533 31 55-99	G	N
533 05 36-52	C		533 30 22-08	F		533 30 68-58	A		533 31 59-02	K	N
533 05 52-00	J	N	533 30 23-03	D		533 30 71-12	C		533 31 66-67	D	
533 05 52-73	BCFG		533 30 23-07	A		533 30 71-13	K		533 31 68-10	L	
533 05 55-11	K		533 30 23-14	A		533 30 71-74	G		533 31 68-16	L	
533 05 60-30	BC		533 30 23-21	C		533 30 73-62	G		533 31 70-17	I	
533 05 61-80	J		533 30 23-31	A		533 30 73-81	L	N	533 31 70-18	I	
533 05 64-72	G		533 30 23-35	E		533 30 78-20	L		533 31 70-19	C	
533 05 69-07	B		533 30 23-38	F		533 30 83-84	D		533 31 70-41	I	
533 05 71-58	C		533 30 23-57	F		533 30 83-99	D		533 31 77-05	I	
533 05 72-20	K		533 30 23-60	F		533 30 84-59	G		533 31 80-73	M	
533 05 73-25	J		533 30 23-79	F		533 30 85-23	E		533 31 83-04	A	N
533 05 74-44	K		533 30 23-80	F		533 30 87-19	D		533 31 93-87	B	
533 05 74-76	K		533 30 23-83	F		533 30 88-97	A		533 31 93-88	B	
533 05 75-47	K	N	533 30 24-98	A		533 30 88-98	A		533 31 96-22	K	
533 05 75-51	K		533 30 25-24	A		533 30 90-11	J		533 31 98-68	J	
533 05 77-69	K		533 30 25-83	D		533 30 92-13	F		533 32 05-31	D	N
533 05 82-47	I		533 30 25-88	D		533 30 92-35	B		533 32 07-15	L	
533 05 83-25	F		533 30 25-94	D		533 30 92-85	K		533 32 07-16	L	
533 05 83-26	F		533 30 26-11	J		533 30 92-95	M		533 32 08-42	L	

N=New part  
 Neues teil  
 Nouvelle piece  
 Nueva pieza  
 Ny detalj

MODEL NUMBER 4140H

PART NUMBER	SQUARE	NOTE	PART NUMBER	SQUARE	NOTE	PART NUMBER	SQUARE	NOTE	PART NUMBER	SQUARE	NOTE
533 32 08-43	L										
533 32 08-44	L										
533 32 08-45	L										
533 32 09-22	G										
533 32 13-06	G										
533 32 15-16	C										
533 32 18-10	A										
533 32 20-68	B	N									
533 32 20-69	B										
533 32 21-17	I										
533 32 21-74	L										
533 32 21-75	L										
533 32 24-94	M										
533 32 24-95	M										
533 32 28-59	L										
533 32 29-59	D										
533 32 29-80	M										
533 32 37-31	A										
533 32 37-36	D										
533 32 47-95	A										
533 32 49-36	E										
533 32 50-09	E										
533 32 51-03	I										
533 32 52-32	K										
533 32 61-08	K										
533 32 64-80	I	N									
533 32 68-93	I										
533 32 69-25	E	N									
533 32 73-50	K	N									
533 32 73-52	K	N									
533 32 73-55	K	N									
533 32 80-51	J	N									
533 32 82-57	J	N									
533 32 93-64	J	N									
533 33 08-47	A	N									
533 33 11-84	A										
533 33 13-79	A	N									
533 33 18-09	L										
533 33 18-17	L										
533 33 19-31	K	N									
533 33 20-58	L										
533 33 20-96	L										
533 33 21-33	A	N									
533 33 23-51	J	N									
533 41 23-49	DE										
533 42 10-51	D										
533 44 63-63	DJ										
533 45 63-78	A										
533 45 66-52	E										
533 45 67-22	D										
533 99 53-46	A										
533 99 64-16	C										
734 11 52-01	BM										
734 11 63-01	J										
734 11 65-41	E										
734 11 78-01	I										
872 11 05-06	GIJ										
872 11 05-08	J										
872 14 05-05	F										
873 22 06-00	I										
873 68 04-00	E										
874 61 06-24	D										
874 76 04-12	EK										
874 76 05-32	E										
874 78 04-14	AB										
874 78 05-44	D										
874 78 06-16	D										
874 78 06-48	C										

www.emc-motoculture.com

N=New part  
 Neues teil  
 Nouvelle piece  
 Nueva pieza  
 Ny detalj