

**REPAIR PARTS MANUAL**  
**MODEL NO. PF12T92RB (96061015001)**  
**Lawn Tractor**

---



**PERFORMANCE**  
**POWER** 

# HOW TO USE THIS MANUAL

This manual is designed to provide the customer with a means to identify the parts on his/her tractor when ordering repair parts. The illustrations may or may not represent the actual assemblies; therefore, it is not recommended to use this manual as a guide to assemble or disassemble the tractor. Some hardware and parts are drawn larger in order to more readily identify them.

Each tractor has its own model number.

The model number for your tractor can be found on the fender under the seat.

When ordering parts, always give the following information:

- Product - "Tractor"
- Model Number - "PF12T92RB(96061015001)"
- Part Number
- Part Description

## TABLE OF CONTENTS

<b>SCHEMATIC .....</b>	<b>3</b>
<b>ELECTRICAL.....</b>	<b>4-5</b>
<b>CHASSIS.....</b>	<b>6-7</b>
<b>DRIVE.....</b>	<b>8-9</b>
<b>STEERING .....</b>	<b>10-11</b>
<b>SEAT .....</b>	<b>12</b>
<b>MOWER LIFT .....</b>	<b>13</b>
<b>ENGINE.....</b>	<b>14-15</b>
<b>MOWER DECK .....</b>	<b>16-17</b>
<b>BAGGER.....</b>	<b>18-19</b>
<b>DECALS.....</b>	<b>20</b>

[www.emc-motoculture.com](http://www.emc-motoculture.com)

# TRACTOR- -MODEL NO.PF12T92RB (96061015001) PRODUCT NO. 960 61 01-50 SCHEMATIC

03051\_197438 (NO LIGHTS)

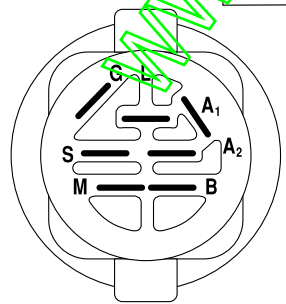
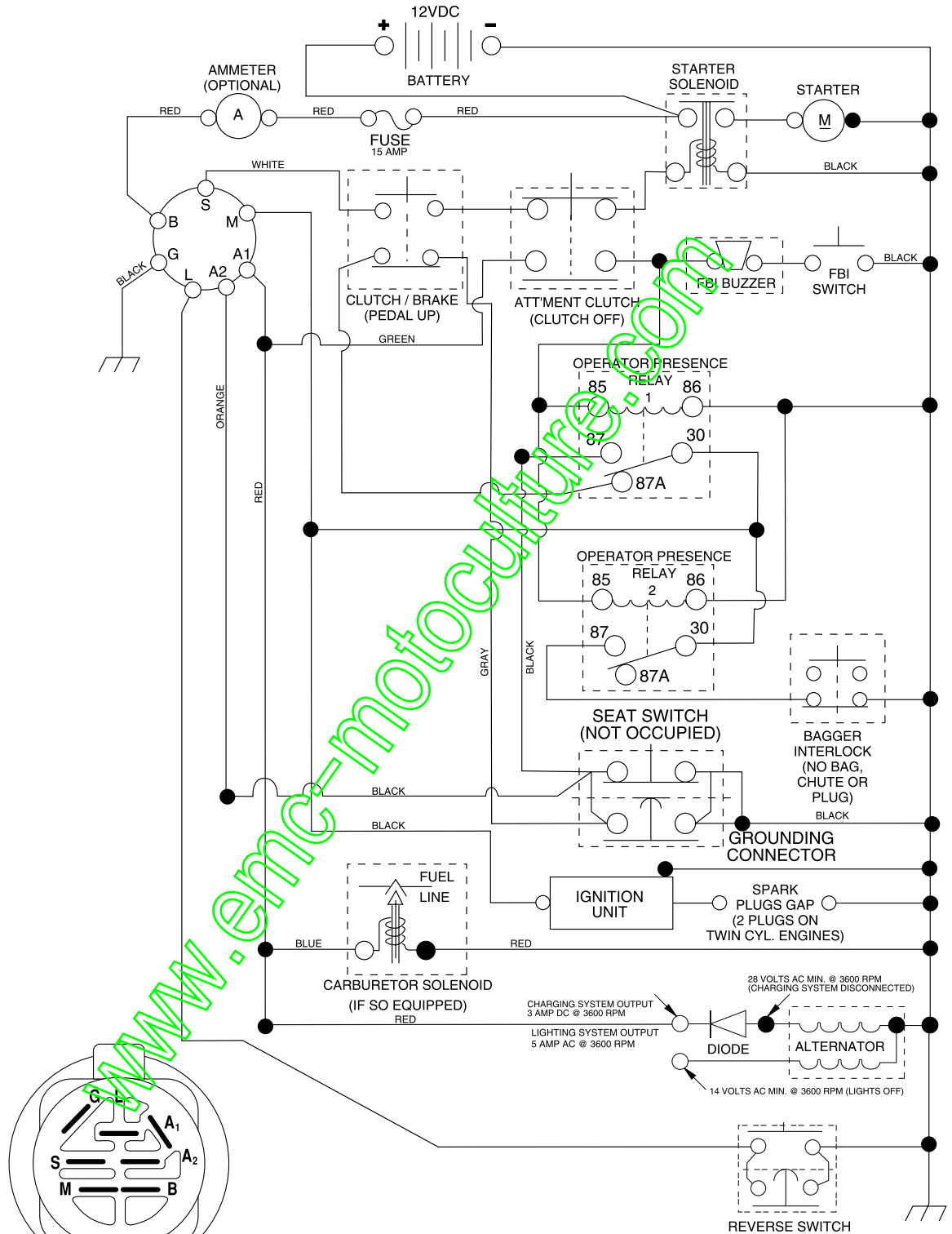

**IGNITION SWITCH**

POSITION	CIRCUIT "MAKE"
OFF	M+G+A1
RUN/OVERRIDE	B+A1
RUN	B+A1 L+A2
START	B + S + A1

03051

**WIRING INSULATED CLIPS**

**NOTE:** IF WIRING INSULATED CLIPS WERE REMOVED FOR SERVICING OF UNIT, THEY SHOULD BE REPLACED TO PROPERLY SECURE YOUR WIRING.

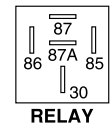



# REPAIR PARTS

TRACTOR- -MODEL NO.PF12T92RB (96061015001) PRODUCT NO. 960 61 01-50  
ELECTRICAL

KEY NO.	PART NO.	DESCRIPTION
1	532 16 34-65	Battery
2	874 76 04-12	Bolt Hex Hd 1/4-20 unc x 3/4
16	532 17 61-38	Switch Interlock
24	532 12 47-80	Cable Starter 6 Ga. 11" Red
25	532 16 59-87	Cable Battery Crd 56" Red
26	532 17 51-58	Fuse
27	873 51 04-00	Nut Keps Hex 1/4-20 unc
28	532 12 77-25	Cable Ground 6 Ga. 18" Black
29	532 19 27-49	Switch Seat
30	532 19 33-50	Switch Ignition
33	532 14 04-01	Key Ign Molded
40	532 19 74-38	Harness Ign
41	871 11 04-08	Bolt Flk Fin Hex 1/4-20 unc x 1/2
42	532 13 15-63	Cover Terminal Red
43	532 19 25-07	Solenoid
48	532 14 08-44	Adapter Ammeter Rectangular
58	532 16 94-19	Buzzer Crd
59	532 18 03-79	Switch FBI CRD
66	817 49 06-08	Screw Thdrd 3/8-16 x 1/2 Ty-Tt
81	532 10 97-48	Relay Asm
92	532 19 66-15	Harness Pigtail
93	532 19 25-40	Screw Plastite 10-14 x 2.0
94	532 19 18-34	Module Reverse

**NOTE:** All component dimensions given in U.S. inches.  
1 inch = 25.4 mm.

# REPAIR PARTS

TRACTOR- -MODEL NO.PF12T92RB (96061015001) PRODUCT NO. 960 61 01-50  
CHASSIS AND ENCLOSURES

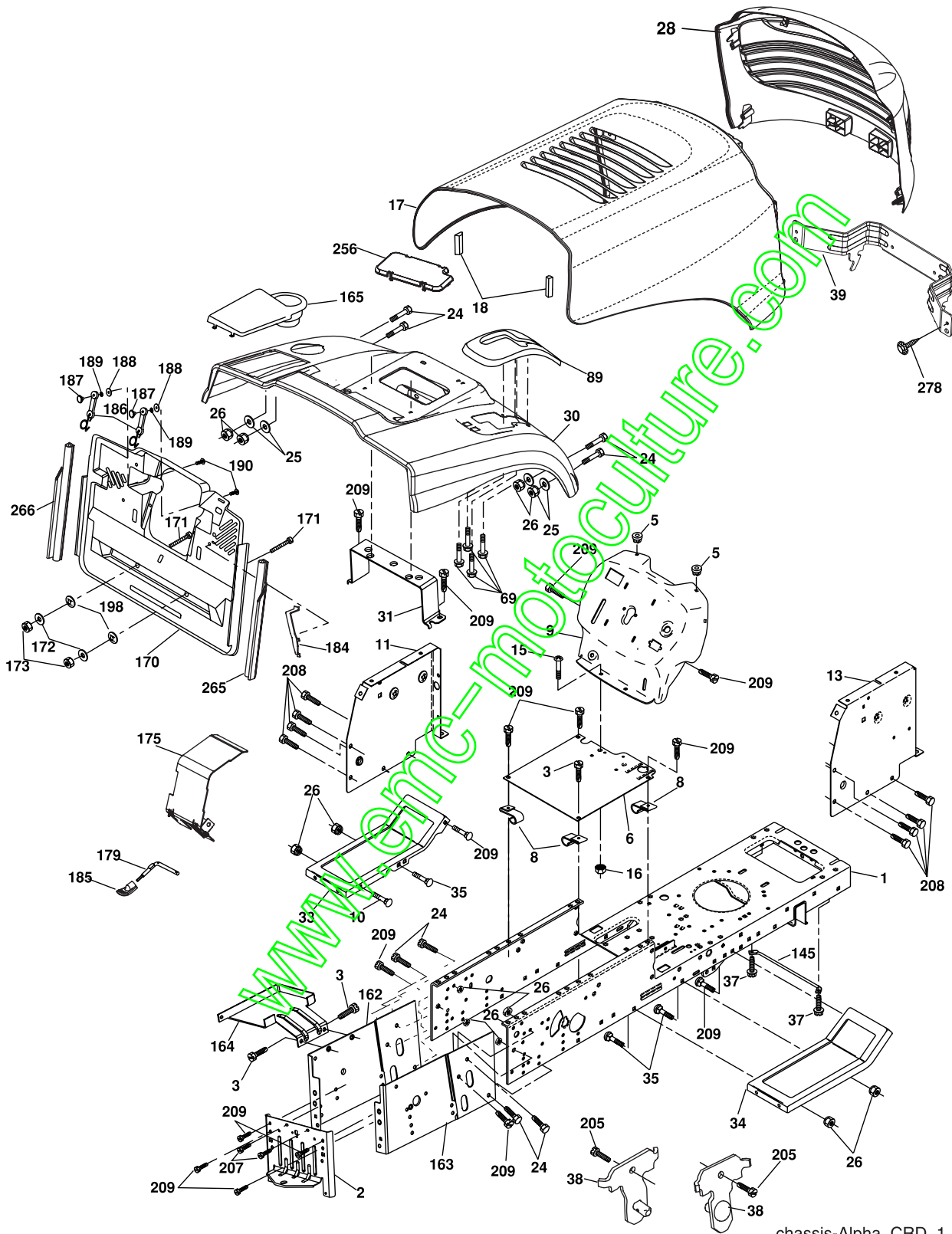

chassis-Alpha\_CRD\_1

# REPAIR PARTS

## TRACTOR- -MODEL NO.PF12T92RB (96061015001) PRODUCT NO. 960 61 01-50 CHASSIS AND ENCLOSURES

KEY NO.	PART NO.	DESCRIPTION	KEY NO.	PART NO.	DESCRIPTION
1	532 17 46-20	Chassis	163	532 18 03-83	Bracket Exten Chassis Rh CRD
2	532 18 03-84	Drawbar	164	532 16 56-05	Support Battery CRD
3	817 06 06-12	Screw 3/8-16 x 3/4	165	532 18 13-56	Cover Battery
5	532 15 52-72	Bumper Hood/Dash	170	532 19 94-88	Backplate CRD
6	532 18 44-19	Saddle	171	872 14 06-20	Bolt Rdhd Sqnk 3/8-16 x 2-1/2 Gr. 5
8	532 12 64-71	Clip Insulator 13/32 Mtg. Hole	172	819 13 20-16	Washer 13/32 x 1-1/4 x 16 Ga.
9	532 19 46-88	Dash	173	873 51 06-09	Nut, Keps Hex 3/8-16 unc
10	872 14 06-08	Bolt, Carriage 3/8-16 x 3/4	175	532 18 82-03	Door Trap
11	532 17 49-96	Panel, Dash, L.H.	179	532 18 82-02	Rod Pivot FBI CRD
13	532 18 17-19	Panel, Asm. Dash R.H.	184	532 17 46-62	Bracket Actuator Bagger CRD
15	874 18 05-12	Screw, Machine, Truss Head 5/16-18 unc x 3/4	185	532 16 11-01	Knob Rod Brake Parking
16	873 51 05-00	Nut	186	532 16 07-93	Latch Asm Mulch/Bagger
17	532 40 35-15	Hood	187	532 12 50-04	Nut Weld
18	532 18 49-21	Bumper Hood	188	819 06 12-16	Washer #10
24	874 78 06-16	Bolt	189	810 07 10-00	Washer Lock #10
25	819 13 13-12	Washer 13/32 x 13/16 x 12 Ga.	190	871 08 10-10	Screw Pan Hd Phillip 10-24 x 5/8
26	873 80 06-00	Nut	198	532 16 89-37	Nut, Push
28	532 19 47-98	Grille	205	817 49 06-08	Screw Thdrol 3/8-16 x 1/2
30	532 40 35-18	Fender	207	817 67 05-08	Screw Thdrl. 5/16-18 x 1/2
31	532 16 51-56	Bracket, Fender Support	208	817 67 06-08	Screw Thdrol 3/8-16 x 1/2
33	532 40 34-11	Footrest, L.H.	209	817 00 06-12	Screw Hex Wsh Thdrol 3/8-16
34	532 40 34-10	Footrest, R.H.	256	532 18 13-61	Cover Fender Rack
35	872 11 06-06	Bolt	265	532 18 57-04	Seal RH Side Bagger
37	817 49 05-08	Screw Thdrol 5/16-18 x 1/2 TYT	266	532 18 57-03	Seal LH Side Bagger
38	532 18 17-48	Bracket Asm Pivot Mower Rear	278	532 19 16-11	Screw 10 x 3/4 Single Lead Hex
39	532 18 75-68	Bracket Pivot	--	532 19 39-35	Plug Switch Light
69	532 14 24-32	Screw HxWsh Hi-Lo	--	532 00 54-79	Plug Button
89	532 19 73-39	Console CRD 6 Sp. 418			
145	532 15 65-24	Rod Pivot Chassis/Hood			
162	532 18 03-82	Bracket Exten Chassis Lh CRD			

**NOTE:** All component dimensions given in U.S. inches.  
1 inch = 25.4 mm.



# REPAIR PARTS

TRACTOR- -MODEL NO.PF12T92RB (96061015001) PRODUCT NO. 960 61 01-50  
DRIVE

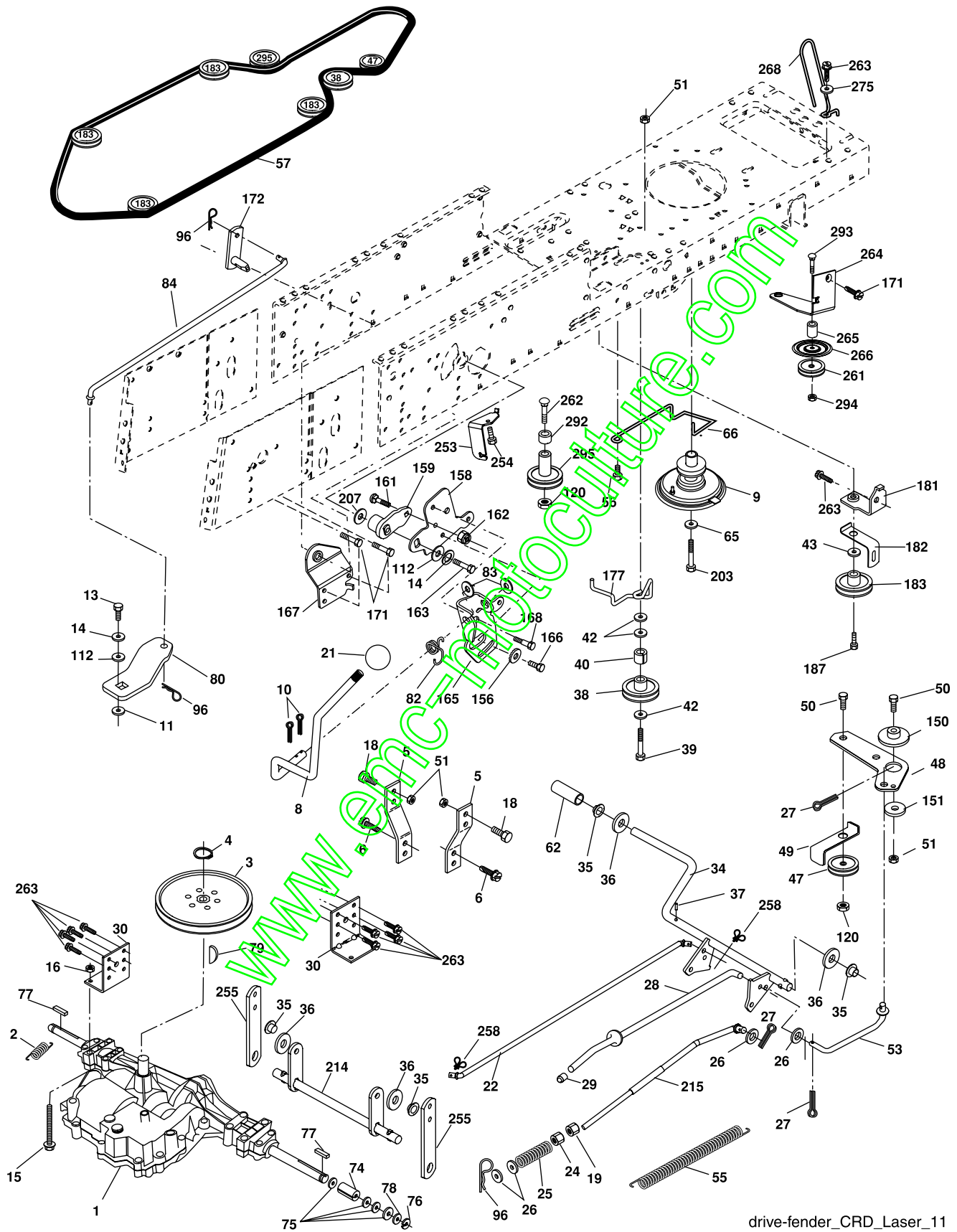

drive-fender\_CRD\_Laser\_11



# REPAIR PARTS

TRACTOR- -MODEL NO.PF12T92RB (96061015001) PRODUCT NO. 960 61 01-50  
DRIVE

KEY NO.	PART NO.	DESCRIPTION	KEY NO.	PART NO.	DESCRIPTION
1	-----	Transaxle Peerless 206-546 (Order parts from transaxle manufacturer)	78	532 12 17-48	Washer 25/32 x 1-5/8 x 16 Ga.
2	532 14 66-82	Spring Brake Return	79	532 12 50-96	Key Woodruff
3	532 16 59-99	Pulley Transaxle	80	532 14 50-90	Arm Shift PMST 20" Tires
4	812 00 00-28	Ring Retainer #5100-62	82	532 16 57-11	Spring, Torsion
5	532 12 15-20	Strap torque 30 degrees	83	819 17 12-16	Washer 17/32 x 3/4 x 16 Ga.
6	817 06 05-12	Screw 5/16-18 x 3/4	84	532 16 56-21	Link Shift CRD Pmst 18" Tires
8	532 19 27-06	Rod Shift	96	532 12 47-88	Spring, Retainer 1"
9	532 18 03-54	Clutch Noram	112	819 09 12-10	Washer 9/32 x 3/4 x 10 Ga.
10	876 02 04-16	Pin, Cotter 1/8 x 1	120	873 90 06-00	Nut Lock Flg. 3/8-16 unc
11	532 10 57-01	Washer Plate Shf .3888 sq hole	150	532 16 58-50	Bushing, Bellcrank Grnd Dr
13	874 55 04-12	Bolt 1/4-28 Unf Gr. 8 w/patch	151	819 13 32-10	Washer 13/32 x 2 x 10 Ga.
14	810 04 04-00	Washer, Lock Hvy Helical	156	532 16 60-02	Washer Srrd 5/16 ID x 1.125
15	874 49 05-44	Bolt Hex Flghd 5/16-18 Gr. 5	158	532 16 55-89	Bracket Shift Mount
16	873 80 05-00	Nut, Lock Hex w/Ins 5/16-18 unc	159	532 18 39-00	Hub Shift
18	874 78 06-16	Bolt Hex 3/8-16 unc x 1 Gr. 5	161	872 14 04-06	Bolt Rdhd Sqnk 1/4-20 x 3/4 Gr 5
19	873 80 06-00	Nut, Lock Hex w/Wsh 3/8-16 unc	162	873 68 04-00	Nut Crownlock 1/4-20 unc
21	532 10 69-33	Knob Duckhead	163	874 78 04-16	Bolt Hex Fin 1/4-20 unc x 1 Gr 5
22	532 17 56-07	Rod, Brake CRD	165	532 16 56-23	Bracket Pivot Lever
24	873 35 06-00	Nut	166	817 49 05-10	Screw 5/16-18 x 5/8
25	532 10 68-88	Spring, Rod, Brake	167	532 16 55-88	Bracket Support Shift CRD
26	819 13 13-16	Washer 13/32 x 13/16 x 16 Ga.	168	532 16 54-92	Bolt Shoulder 5/16-18 x .561
27	876 02 04-12	Pin, Cotter 1/8 x 3/4	171	817 49 06-08	Screw Thdrol 3/8-16 x 1/2 Ty-Tt
28	532 17 57-65	Rod, Parking Brake	172	532 16 56-35	Shaft Asm Shift Front CRD PMST
29	532 07 16-73	Cap Brake Parking	177	532 16 59-32	Keeper Flat Idler 3.06" CRD
30	532 17 49-73	Bracket, Mfg. Transaxle	181	532 18 02-11	Bracket Idler Ground Drive CRD
34	532 17 55-78	Shaft, Asm Pedal Foot	182	532 18 26-82	Keeper Belt 2.5" Od V-Idler CRD
35	532 12 01-83	Bearing, Nylon	183	<b>532 19 95-32</b>	Pulley V-Idler
36	819 21 16-16	Washer 21/32 x 1 x 16 Ga.	187	817 58 05-20	Screw 5/16-18 x 1.25
37	532 12 49-63	Pin, Roll 3/16 x 1"	203	871 17 07-80	Bolt Hex 7/16-20 x 5
38	532 16 59-36	Pulley, Flat	207	532 16 98-45	Washer Nylon Rear
39	874 76 06-44	Bolt Fin Hex 3/8-16 unc x 2-3/4	214	532 17 56-09	Shaft Asm Blade
40	532 12 49-65	Spacer, Split 395 x 59 Bzp	215	532 19 95-80	Rod Brake Secondary
42	819 13 13-12	Washer 13/32 x 13/16 x 12 Ga.	253	532 17 50-28	Bracket Cable Chassis
43	819 11 10-12	Washer 11/32 x 5/8 x 12 Ga.	254	817 00 06-16	Screw 3/8-16 x 1
47	532 12 77-83	Pulley, Idler, V Groove Plasic	255	532 17 56-08	Brace Shaft Brake Mtg.
48	532 15 44-07	Bellcrank Clutch Grnd Drv	258	532 17 80-62	Clip Retainer
49	532 12 32-05	Retainer, Belt Style Spring	261	532 13 14-94	Pulley Idler
50	872 11 06-12	Bolt 3/8-16 unc x 1-1/2	262	872 11 06-22	Bolt RDHD 3/8-16 unc x 2-3/4 Gr.5
51	873 68 06-00	Nut, Crownlock 3/8-16 unc	263	817 00 06-12	Screw 3/8-16 x 3/4
53	532 19 96-52	Link, Clutch 7.66	264	532 19 76-08	Bracket Clutch Mtg.
55	532 10 57-09	Spring, Return, Clutch	265	532 18 20-13	Spacer Idler Chassis
56	817 06 06-20	Screw 3/8-16 x 1-1/4	266	532 18 20-61	Shield Idler Mower
57	532 16 56-31	V-Belt Kev PMST CRD	268	<b>532 18 24-02</b>	Guard, Muffler
62	532 12 48-72	Cover, Pedal	275	<b>819 13 16-14</b>	Washer 13/32 x 1 x 14 Ga
65	810 04 07-00	Washer	292	532 40 02-71	Spacer
66	532 15 47-78	Keeper, Belt Engine F-Proof	293	<b>872 14 06-28</b>	Bolt RDHD SQNK 3/8-16 x 3-1/2
74	532 13 70-57	Spacer Axle	294	532 19 70-33	Nut Jam 3/8-16
75	532 12 17-49	Washer 25/32 x 1-1/4 x 16 Ga.	295	532 17 91-14	Pulley Idler
76	812 00 00-01	Ring, E			
77	532 12 35-83	Key, Square			

**NOTE:** All component dimensions given in U.S. inches  
1 inch = 25.4 mm

# REPAIR PARTS

TRACTOR- -MODEL NO.PF12T92RB (96061015001) PRODUCT NO. 960 61 01-50  
STEERING ASSEMBLY

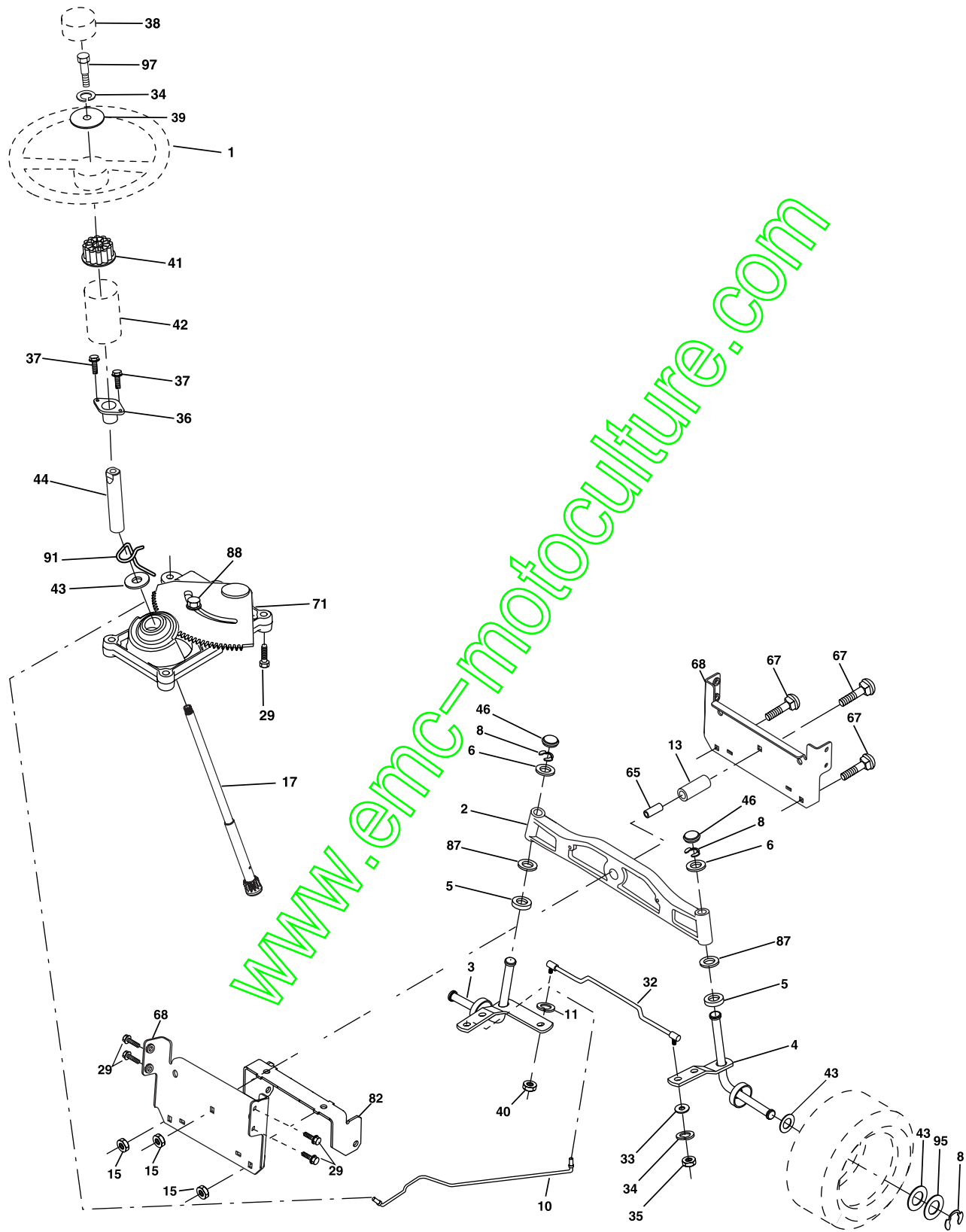

steering\_pl.lt\_60

# REPAIR PARTS

TRACTOR- -MODEL NO.PF12T92RB (96061015001) PRODUCT NO. 960 61 01-50  
STEERING ASSEMBLY

KEY NO.	PART NO.	DESCRIPTION
1	532 18 67-80	Steering Wheel
2	532 18 47-06	Axle Asm Cast Iron Lt
3	532 16 98-40	Spindle Assembly, L.H.
4	532 16 98-39	Spindle Assembly, R.H.
5	532 12 49-31	Bearing, Race, Thrust, Hardened
6	532 12 17-48	Washer 25/32 x 1-5/8 x 16 Ga.
8	812 00 00-29	Ring, Klip
10	532 17 51-21	Link, Drag
11	810 04 06-00	Washer, Lock
13	532 13 65-18	Spacer Brg Axle Front
15	532 14 52-12	Nut Hex Flange Lock
17	532 19 07-53	Shaft, Steering
29	817 00 06-12	Screw 3/8-16 x 3/4
32	532 17 01-62	Rod, Tie
33	819 11 12-16	Washer 11/32 x 3/4 x 16 Ga.
34	810 04 05-00	Washer Lock Hvy Hlcl Spr 5/16
35	873 54 05-00	Crownlock Nut 5/16-24 unf 3847
36	532 15 50-99	Bushing, Steering
37	532 15 29-27	Screw TT #10-32 x 5 x 3/8 Flange
38	532 19 29-16	Cap Wheel Steering
39	819 11 38-12	Washer 11/32 ID x 2- 3/8 OD x 12 Ga.
40	876 54 06-00	Nut Lock 3/8-24
41	532 18 67-37	Adaptor, Steering Wheel
42	532 16 96-33	Boot, Steering Dash P/L Mtl
43	532 12 17-49	Washer 25/32 x 1-1/4 x 16 Ga.
44	532 19 07-52	Extension Steering Shaft
46	532 12 12-32	Cap, Spindle
65	532 16 03-67	Spacer Brace Axle
67	872 11 06-18	Bolt Rdhd Sqnk 3/8-16 x 2-1/4
68	532 16 98-27	Brace Axle
71	532 17 51-46	Steering Asm.
82	532 19 99-78	Bracket Susp Chassis Front
87	532 17 39-66	Washer Flat .781 x 1 1/2 x .14
88	532 17 51-18	Bolt Shoulder 7/16-20 unc
91	532 17 55-53	Clip Steering
95	532 18 89-67	Washer
97	874 78 05-64	Bolt 5/16-18 unc x 4" L. Gr. 5

**NOTE:** All component dimensions given in U.S. inches.  
1 inch = 25.4 mm.

# REPAIR PARTS

TRACTOR- -MODEL NO.PF12T92RB (96061015001) PRODUCT NO. 960 61 01-50  
SEAT ASSEMBLY

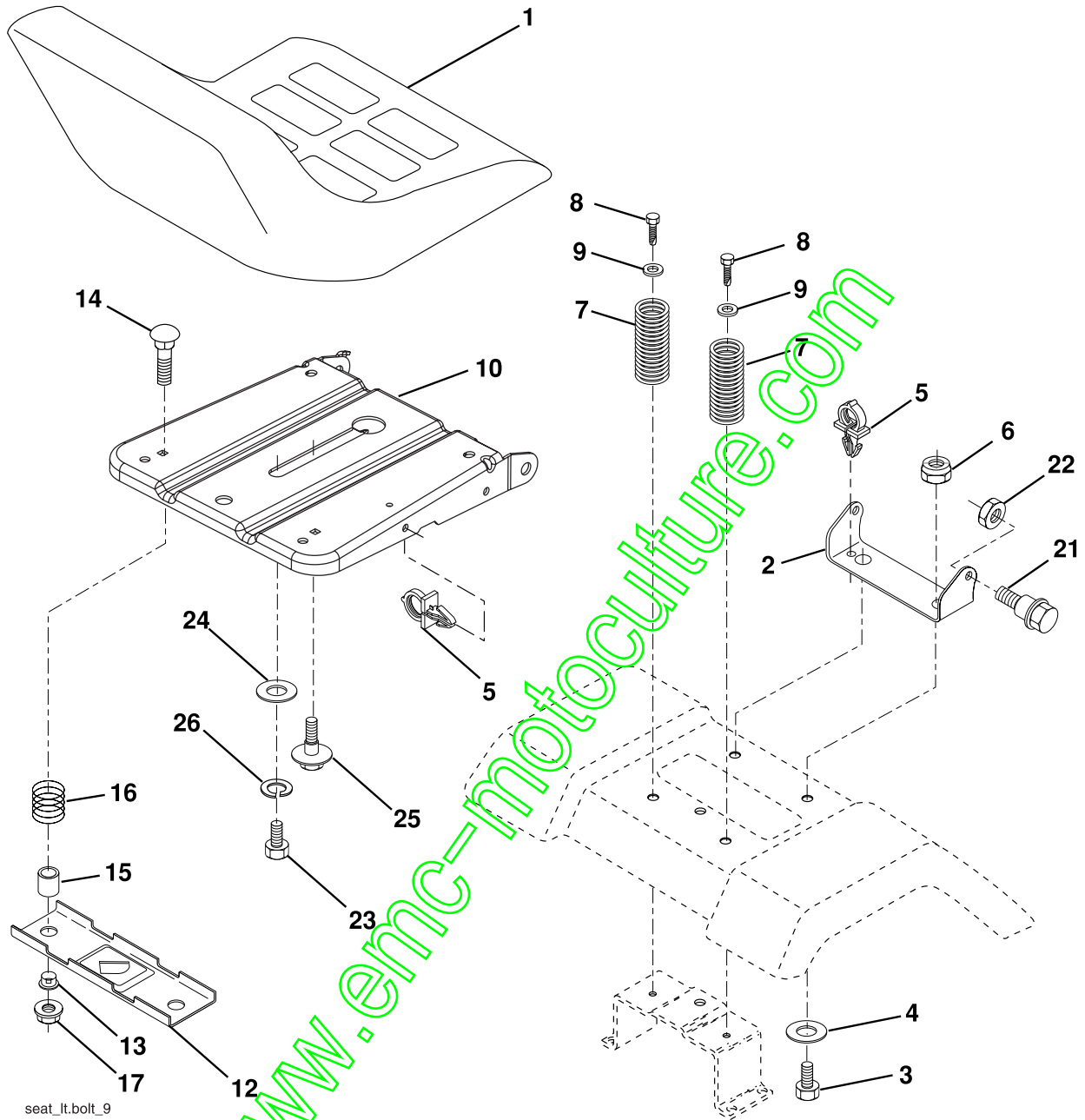

KEY NO.	PART NO.	DESCRIPTION	KEY NO.	PART NO.	DESCRIPTION
1	532 40 10-42	Seat	14	872 05 04-12	Bolt Rdhd Sht Nk 1/4-20 x 1-1/2
2	532 14 05-51	Bracket Pnt Pivot Seat (blk )	15	532 13 43-00	Spacer Split
3	871 11 06-16	Bolt Fin Hex 3/8-16 x 1	16	532 12 12-50	Spring Cprsn Plate SW 1.310 Ga.
4	819 13 16-10	Washer Flat 13/32 x 1 x 10 Ga.	17	532 12 39-76	Nut Lock 1/4 Lge Flg Gr 5 Zinc
5	532 14 50-06	Clip Push In Hinged	21	532 17 18-52	Bolt Shoulder 5/16-18 unc-2A
6	873 80 06-00	Nut Lock Hx w/Ins. 3/8-16	22	873 80 05-00	Nut Hex Lock w/Ins 5/16-18
7	532 12 41-81	Spring Seat Cprsn 2 250 Blk Zi	23	871 11 08-14	Bolt Hex BLK
8	817 00 06-16	Screw 3/8-16 x 1-1/2	24	819 17 19-12	Washer 17/32 x 1-3/16 x 12 Ga.
9	819 13 16-14	Washer 13/32 x 1 x 14 Ga.	25	532 12 70-18	Bolt Shoulder 5/16-18 x 62
10	532 19 55-30	Pan Pnt Seat	26	810 04 08-00	Washer Lock Hvy. HLCL Spr. 1/2
12	532 17 46-48	Bracket Pnt Mounting Switch			
13	532 12 12-48	Bushing Snap Blk Nyl 50 Id			

**NOTE:** All component dimensions given in U.S. inches.  
1 inch = 25.4 mm

# REPAIR PARTS

TRACTOR- -MODEL NO.PF12T92RB (96061015001) PRODUCT NO. 960 61 01-50  
MOWER LIFT

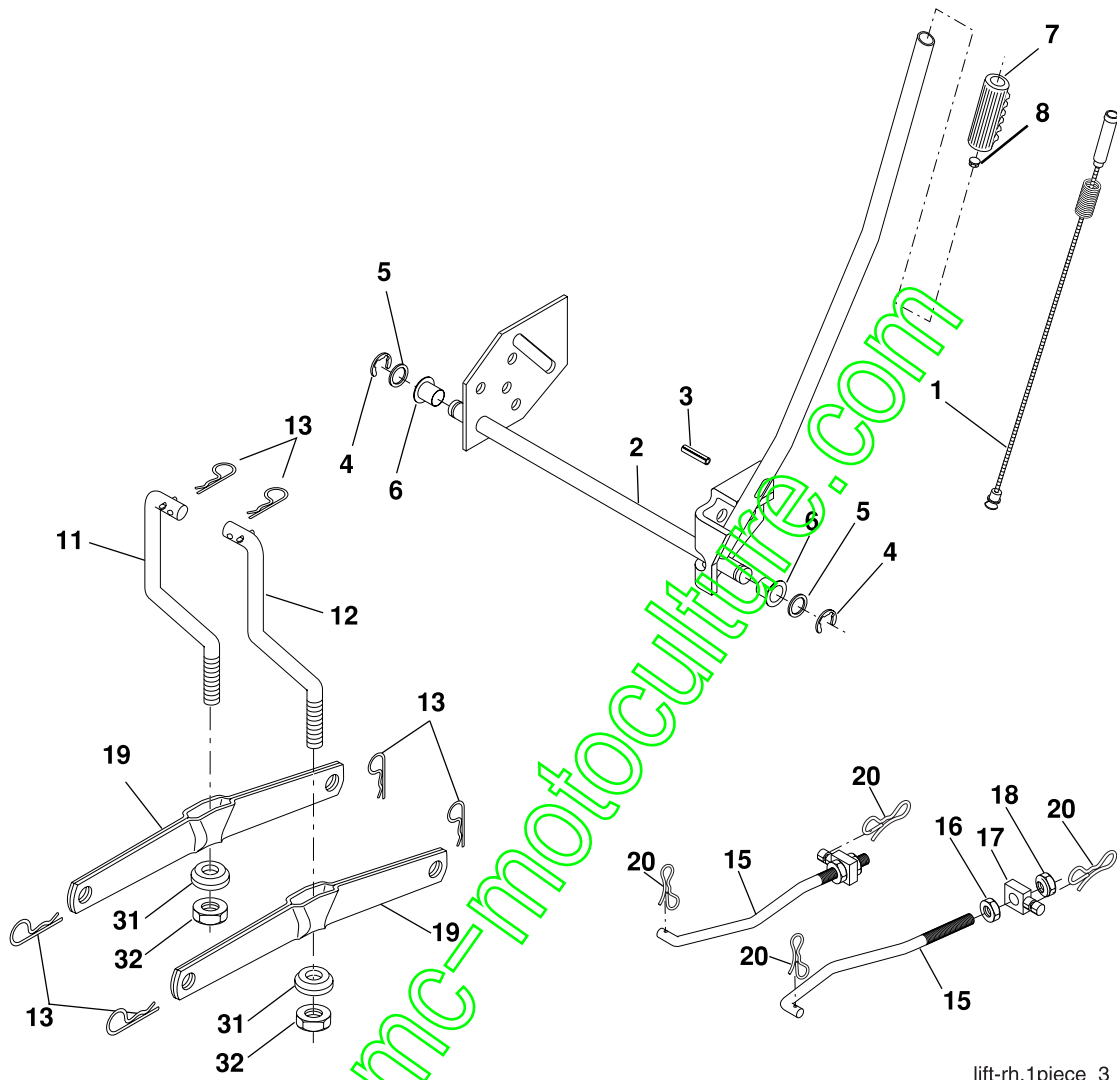

lift-rh.1piece\_3

KEY NO.	PART NO.	DESCRIPTION
1	532 15 94-60	Washer Asm Inner Spring W/ Plunger
2	532 15 94-71	Shaft Asm. Lift
3	532 10 57-67	Pin Groove
4	812 00 00-02	E Ring #5133-62
5	819 21 16-21	Washer 21/32 x 1 x 21 Ga.
6	532 12 01-83	Bearing Nylon
7	532 10 94-13	Grip Handle
8	532 12 45-26	Button Plunger Black
11	532 16 58-29	Link Lift L.H.

KEY NO.	PART NO.	DESCRIPTION
12	532 16 58-31	Link Lift R.H.
13	532 12 46-70	Retainer Spring
15	532 17 32-88	Link Front
16	873 35 08-00	Nut Jam Hex 1/2-13 unc
17	532 17 56-89	Trunnion
18	873 80 08-00	Nut Lock W/Wsh 1/2-13 unc
19	532 13 98-68	Arm Suspension Mower
20	532 19 42-09	Pin Cotter 7/16 Bow Tie Lock
31	532 16 98-65	Bearing, Pvt. Lift.
32	873 54 06-00	Nut Crownlock 3/8-24

**NOTE:** All component dimensions given in U.S. inches.  
1 inch = 25.4 mm

# REPAIR PARTS

TRACTOR- -MODEL NO.PF12T92RB (96061015001) PRODUCT NO. 960 61 01-50  
ENGINE

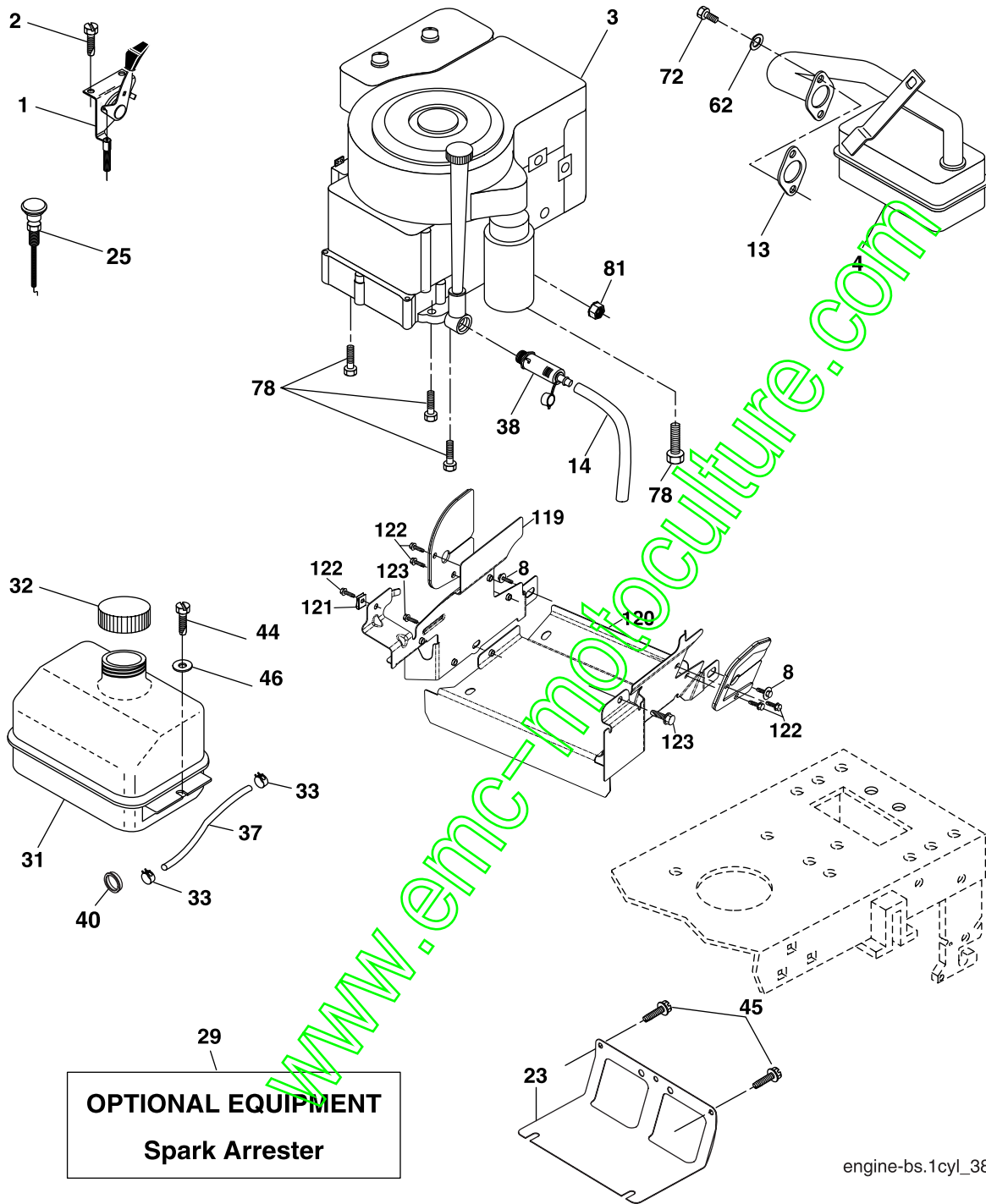

# REPAIR PARTS

TRACTOR- -MODEL NO.PF12T92RB (96061015001) PRODUCT NO. 960 61 01-50  
ENGINE

KEY NO.	PART NO.	DESCRIPTION
1	<b>532 17 05-51</b>	Control Throt /Ch Flag
2	817 72 04-08	Screw Hex Thd Cut 1/4-20 x 1/2
3	-----	Engine Briggs 219807 (Order Parts from Engine Manufacturer)
4	<b>532 17 97-58</b>	Muffler
8	532 17 18-77	Bolt 5/16-18 x 3/4
13	<b>532 16 52-91</b>	Gasket
14	532 14 84-56	Tube Drain Oil Easy
23	532 16 98-37	Shield Browning/Debris Guard
25	<b>532 19 06-95</b>	Control Choke
29	532 13 71-80	Arrestor Spark
31	532 18 77-50	Tank Fuel
32	532 19 77-25	Cap Asm Fuel Top
33	532 12 34-87	Clamp Hose Blk
37	532 13 70-40	Line Fuel 20"
38	532 18 16-54	Plug Drain Oil Easy
40	<b>532 12 40-28</b>	Bushing
44	817 67 04-12	Screw Hexwsh Thdrol 1/4-20 x 3/4
45	817 00 06-12	Screw Hexwsh Thdr 3/8-16 x 3/4
46	819 09 14-16	Washer 9/32 x 7/8 x 16ga
62	810 04 05-00	Washer Lock Wvy HLCL Spr 5/16
72	<b>532 19 23-34</b>	Screw Socket Hd 5/16-18 x .75
78	817 06 06-20	Screw 3/8-16 x 1-1/4
81	873 51 04-00	Nut Keps 1/4-20 unc
119	532 40 06-01	Guard Asm. Engine LH
120	532 40 06-00	Guard Asm. Engine RH
121	532 19 66-88	Clip Threaded
122	532 13 77-29	Screw Thd Roll 1/4-20 x 5/8
123	817 67 05-08	Screw Thdrol 5/16-18 x 1/2

**NOTE:** All component dimensions given in U.S. inches.  
1 inch = 25.4 mm



# REPAIR PARTS

TRACTOR- -MODEL NO.PF12T92RB (96061015001) PRODUCT NO. 960 61 01-50  
MOWER

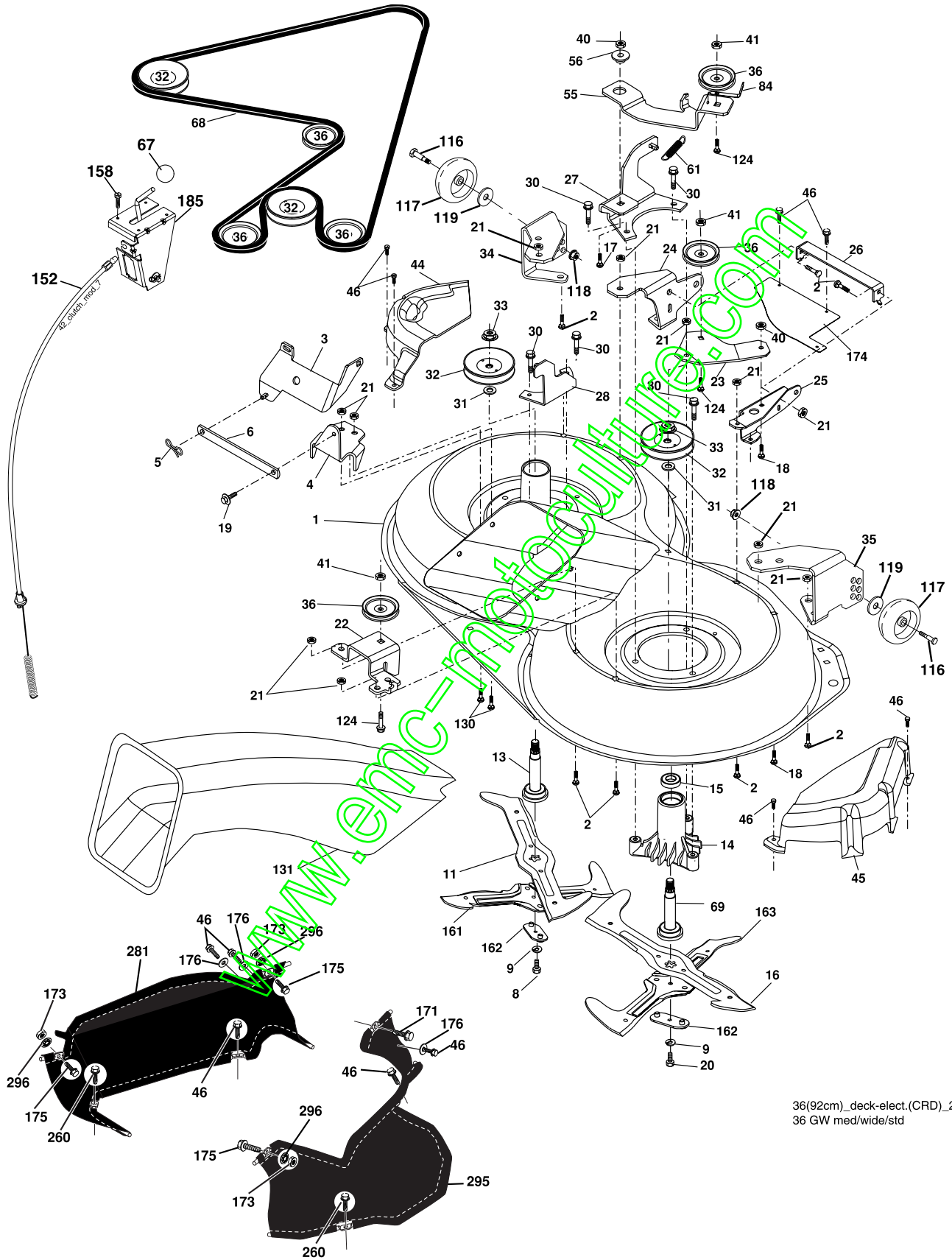

36(92cm)\_deck-elect.(CRD)\_2  
36 GW med/wide/std

# REPAIR PARTS

TRACTOR- -MODEL NO.PF12T92RB (96061015001) PRODUCT NO. 960 61 01-50  
MOWER

KEY NO.	PART NO.	DESCRIPTION	KEY NO.	PART NO.	DESCRIPTION
1	532 40 01-08	Housing Asm. Mower 92 CRD	45	532 17 55-39	Cover Mandrel Rh 92 CRD
2	872 14 05-06	Bolt Rdhd Sqnk 5/16-18 unc x 3/4	46	532 13 77-29	Screw Thd Roll 1/4-20 x 5/8
3	532 16 55-69	Bracket Asm. S-Bar Chass 92 CRD	55	532 19 94-98	Arm Idler 92 CRD
4	532 16 55-58	Bracket Bar Sway Deck 92 CRD	56	532 16 57-23	Spacer Retainer Mower
5	532 12 46-70	Retainer Spring	61	532 16 59-45	Spring Tension Belt
6	532 16 55-57	Bar Sway 92 CRD	67	532 10 69-32	Knob Rd 3/8-16 Plstc Thds Blk
8	532 18 17-12	Bolt 3/8-24 x 1.25 Gr. 8 Patched	68	<del>532 40 20-08</del>	Hex-Belt 92 Mower
9	810 03 06-00	Washer Lock Hvy 3/8 Unplated	69	532 16 54-82	Shaft Asm W/Lwr Brg Rh Thd CRD
11	532 18 63-85	Blade 3-1 Lh 92 CRD	84	532 15 60-85	Keeper Belt Idler
13	532 13 76-45	Shaft Asm. W/Lower Bearing	116	<del>532 16 42-19</del>	Bolt Shoulder
14	532 12 87-74	Housing Mandrel Vented (Machd)	117	532 17 48-73	Wheel Gage
15	532 11 04-85	Bearing Ball Mandrel	118	873 93 06-00	Nut Centerlock 3/8-16 unc
16	532 18 63-86	Blade 3-1 Rh 92 CRD	119	<del>819 12 14-14</del>	Washer 3/8 x 7/8 x 14 Ga.
17	872 14 06-10	Bolt Carriage 3/8-16 x 1-1/4	124	872 11 06-12	Bolt Carr Sh 3/8-16 x 1-1/2 Gr. 5
18	872 11 06-06	Bolt Rdhd Sqnk 3/8-16 x 3/4	130	872 11 05-06	Bolt Rdhdsqnk 5/16-18 unc x 3/4
19	532 13 28-27	Bolt Shoulder 5/16-18 Thd Form	131	532 16 56-61	Chute Bagger CRD 92cm
20	532 18 17-13	Bolt 3/8-24 x 1.25 Gr. 8 Ptch Lhthd	152	532 17 60-74	Cable Clutch CRD
21	873 68 05-00	Nut Crown Lock 5/16-18	158	817 72 04-08	Screw Hex Thd Cut 1/4-20 x 1/2
22	532 19 95-90	Bracket Idler Sprt 92 CRD	161	532 18 63-87	Blade Cross LH 92
23	532 16 54-46	Bracket Idler Sprt RF 92 CRD	162	532 18 08-78	Adapter Blade Cross
24	532 16 52-42	Bracket Suspension LF 92 CRD	163	532 18 63-88	Blade Cross RH 92
25	532 16 52-44	Bracket Suspension RF 92 CRD	171	817 49 06-08	Screw Thdrol 3/8-16 x 1/2
26	532 40 01-10	Brace Susp Frt CRD	173	873 80 06-00	Nut Lock Hex W/INs. 3/8-16 UNC
27	532 16 55-68	Bracket Asm. Susp RR 92 CRD	174	532 40 02-41	Guard Front Susp
28	532 16 55-67	Bracket Asm. Susp LR 92 CRD	175	872 11 06-08	Bolt RDHD SQNK 3/8-16 x 1 Gr.5
30	532 17 39-84	Screw Thd Rolling	176	819 09 14-16	Washer 9/32 x 7/8 x 16 Ga.
31	532 18 76-90	Washer Spacer Mower Vented	185	532 18 82-34	Head Asm. Cable Clutch
32	532 15 35-31	Mandrel Pulleys	260	817 67 06-08	`Screw Thdrol 3/8-16 x 1/2
33	532 40 02-34	Nut Flg Top Lock	281	532 40 02-74	Guard Asm Fabric LH
34	532 40 01-07	Bracket Gauge Wheel Lf 92 CRD	295	532 40 02-75	Guard Asm Fabric RH
35	532 40 01-06	Bracket Gauge Wheel Rf 92 CRD	296	532 40 12-20	Push Nut Round
36	532 14 67-63	Pulley Idler V-Groove Dim 4.25	--	532 18 18-57	Mandrel Asm Service
40	873 68 06-00	Nut Crownlock 3/8-16 unc	--	532 18 18-58	Mandrel Asm CRD Lh Threads SVC
41	873 90 06-00	Nut Lock Flg 3/8-16 unc	--	532 40 03-09	Replacement Mower, Complete (Std. Deck - Order separately guage wheel components key nos. 116 - 119)
44	532 17 55-38	Cover Mandrel Lh 92 CRD			

**NOTE:** All component dimensions given in U.S. inches  
1 inch = 25.4 mm

# REPAIR PARTS

TRACTOR- -MODEL NO.PF12T92RB (96061015001) PRODUCT NO. 960 61 01-50  
BAGGER

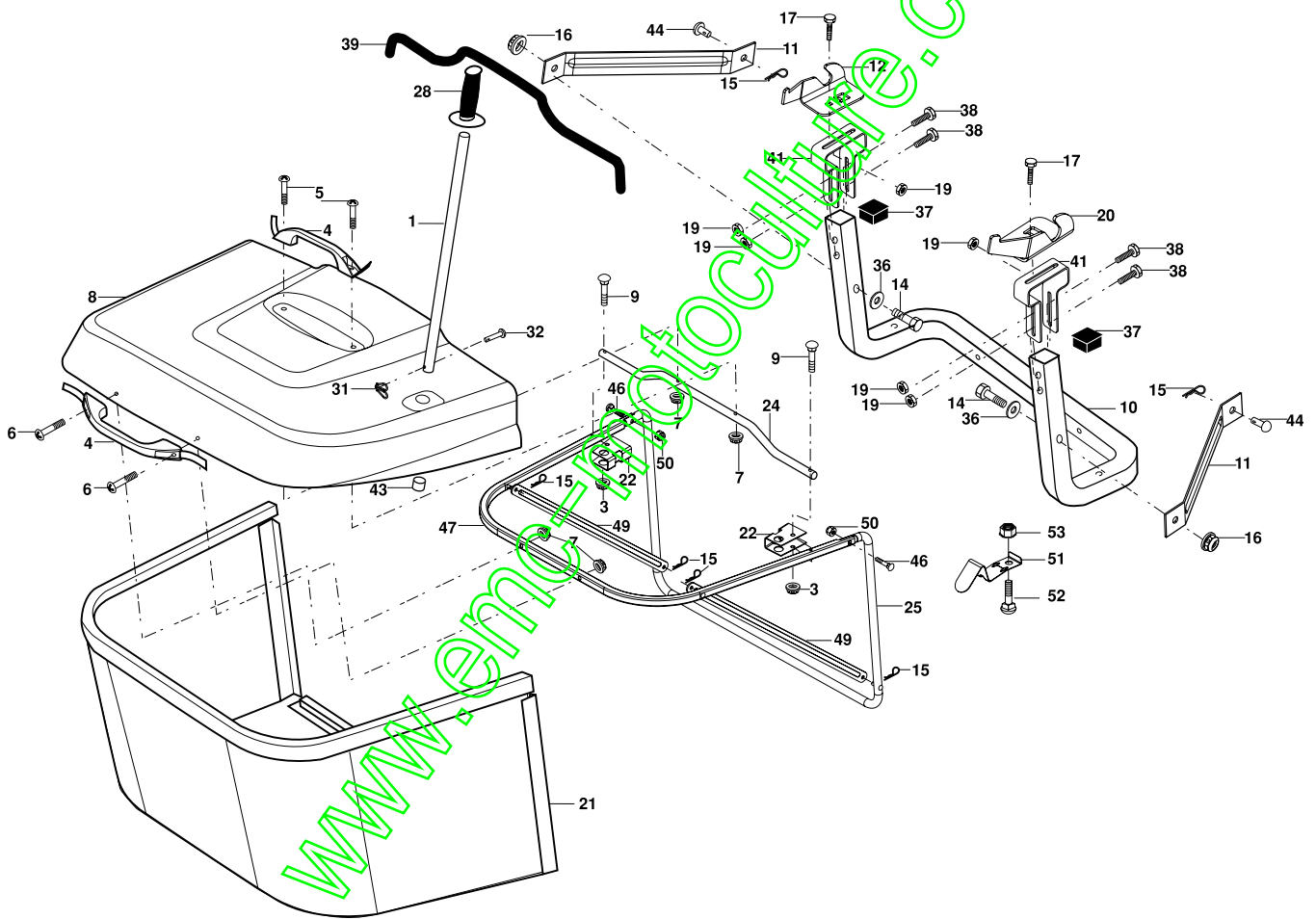

Bagger Asy (CRD)\_11

# REPAIR PARTS

TRACTOR- -MODEL NO.PF12T92RB (96061015001) PRODUCT NO. 960 61 01-50  
BAGGER

KEY NO.	PART NO.	DESCRIPTION
1	532 16 52-49	Tube Handle Bagger CRD
3	532 12 39-76	Nut Lock 1/4 Lge Flg Gr. 5 Zinc
4	532 16 99-16	Handle Bagger w/Lvrs Blk CRD
5	874 98 10-24	Screw Pan Head #10-24 x 1.50 Blk
6	874 98 10-32	Screw Pan Hd
7	873 40 10-00	Nut Wiz Lock Hex Serr/Hd 10-24
8	532 40 35-26	Cover Bagger
9	872 14 04-18	Bolt Carriage 1/4-20 x 2.250 x Gr. 5
10	532 18 12-82	Tube Support Bagger CRD
11	532 16 57-19	Bracket Support Upper Bag CRD
12	532 18 88-48	Bracket Pivotn Lh
14	874 52 06-36	Bolt Carr.
16	873 90 06-00	Nut Lock Flg. 3/8-16 UNC
15	532 12 46-70	Retainer Spring
17	872 14 05-06	Bolt Rdhd Sht Sqnk 5/16 -18 unc x 3/4
19	873 90 05-00	Nut Lock Hexflange 5/16-18
20	532 18 88-47	Bracket Pivot Rh
21	532 19 38-38	Bag Asm CRD
22	532 16 57-81	Bracket Side Bagger CRD
24	532 16 57-83	Tube Pivot Bagger CRD
25	532 19 37-05	Tube Front Bagger CRD
28	532 16 57-87	Grip Handle Black
31	532 16 94-84	Retainer Clip
32	532 12 68-75	Rivet Rd Hd Drilled 3/8 Dia
36	819 13 20-12	Washer 13/32 x 1-1/4 x 12 Ga.
37	532 17 54-01	Plug Support Bagger CRD
38	872 01 05-20	Bolt 5/16-18 x 2-1/2
39	532 18 09-85	Seal 37"
41	532 16 96-83	Bracket Vert Adj Bagger CRD
43	532 17 40-83	Plug Tubing
44	532 19 33-12	Pin Clevis
46	872 14 05-10	Bolt Carr. 5/16-18 x 1-1/4 Gr.5
47	532 19 37-04	Tube Upper Bagger
49	532 19 33-05	Bar Spreader
50	873 80 05-00	Nut Lock Thx w/Ins. 5/16-18 UNC
51	532 19 99-03	Latch Spring Bagger
52	872 14 04-06	Bolt Carr.
53	873 51 04-00	Nut Keps Hex 1/4-20 UNC

**NOTE:** All component dimensions given in U.S. inches  
1 inch = 25.4 mm

# REPAIR PARTS

TRACTOR- -MODEL NO.PF12T92RB (96061015001) PRODUCT NO. 960 61 01-50  
DECALS

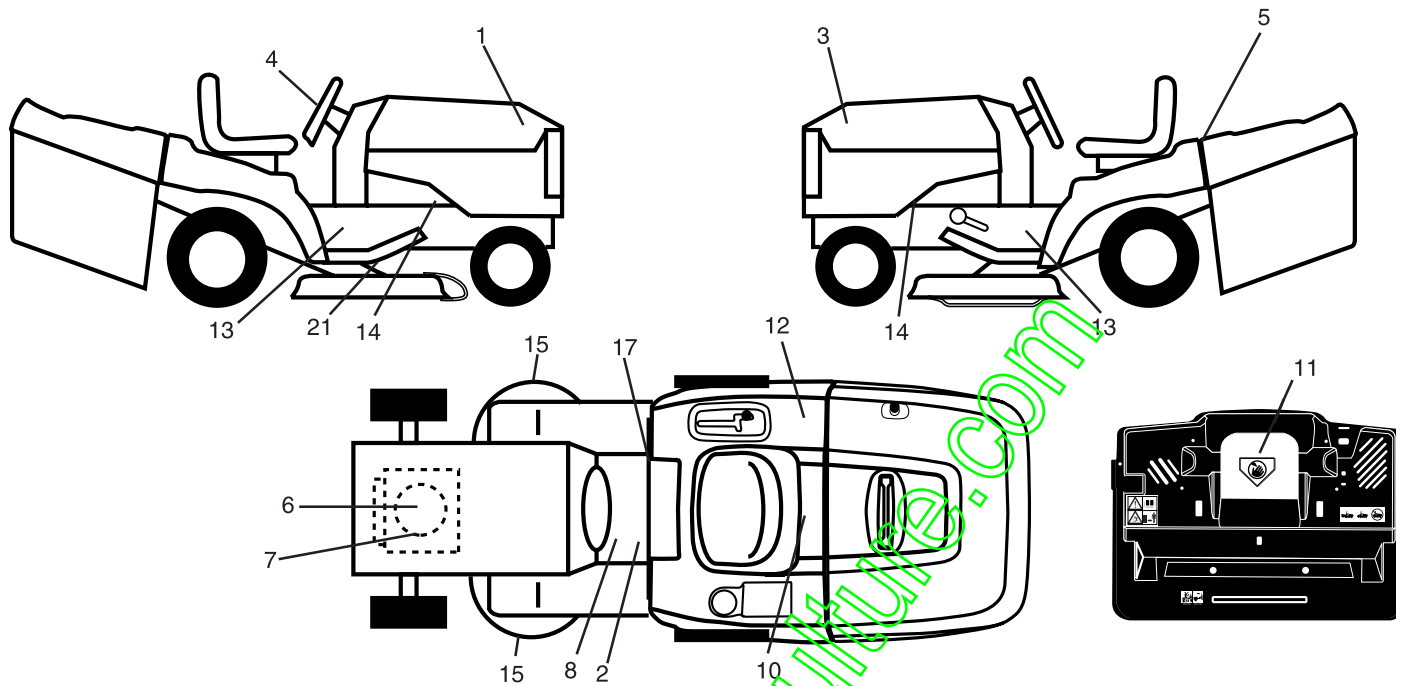

KEY NO.	PART NO.	DESCRIPTION	KEY NO.	PART NO.	DESCRIPTION
1	532 40 29-07	Decal Hood RH	11	532 18 21-66	Decal Mower Cut Finger Symbol
2	532 40 03-89	Decal Warning Symbols CE	12	532 18 04-32	Decal Fender 100 DB/CE
3	532 40 29-08	Decal Hood LH	13	532 40 11-46	Decal Warning Service/Fire
4	532 40 29-12	Decal Steering Wheel	14	532 15 97-36	Decal Chassis Hot Muffler
5	532 40 29-11	Decal Fender Logo	15	532 19 68-42	Decal Warning Cut Finger
6	532 19 68-41	Decal Warning Engine Symbols	17	532 14 08-37	Decal Saddle Brake Parking
7	<b>532 18 61-58</b>	Decal, Engine HP	21	532 16 62-86	Decal Deck Sch 92 CRD
8	532 15 97-37	Decal Brake/Clutch Symbol	—	532 13 83-11	Decal Lift Handle
10	532 14 50-05	Decal Bat Dan/Poi P/L Sym Wpn	—	532 40 08-65	Manual Operator's (Euro)
			—	<b>532 40 36-97</b>	Manual Parts

## WHEELS & TIRES

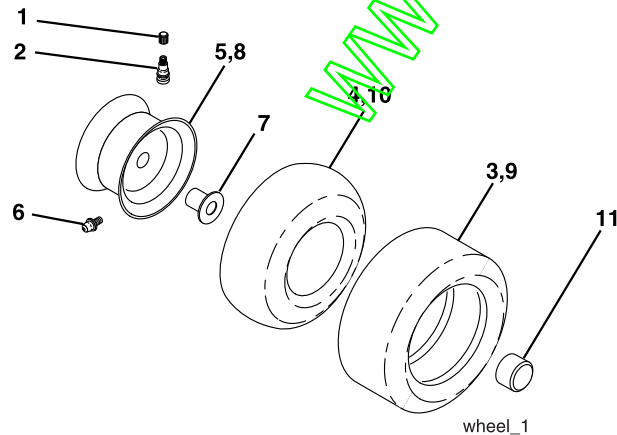

KEY NO.	PART NO.	DESCRIPTION
1	532 05 91-92	Cap Value Tire
2	532 06 51-39	Stem Value
3	532 12 41-57	Tire F Ts 15 x 6 0 - 6 Service
4	532 05 99-04	Tube Inner Front #35060
5	532 18 33-36	Rim Asm Front Service
6	532 12 49-57	Fitting Grease
7	532 12 49-59	Bearing Flange
8	532 13 83-37	Rim Asm 8" rear Service
9	532 12 39-69	Tire R Ts 18 x 8.5-8 Service
10	532 12 49-26	Tube Rear 9 5 x 8 Service
11	532 17 50-39	Cap Axle Blk 1 50 x 1 00
--	532 14 43-34	Sealant, Tire (10 oz. tube)

**NOTE:** All component dimensions given in U.S. inches.  
1 inch = 25.4 mm

[www.emc-motoculture.com](http://www.emc-motoculture.com)