



PIECES DETACHEES

**Tondeuse autoportée
avec aspirateur-collecteur**

SL14H - SBC250

**SG14H-40CE20, 40CE40, 40CE50,
40CE50T, 40E20, 40E40, 40E50
SBC250**



Yvon Béal 21, Av. de l'Agriculture - B.P. 16
Z.I. du Bécet 63014 Clermont-Ferrand Cedex 2
Tél: 04 73 91 93 31 - Télécopie: 04 73 90 23 11
www.yvonbeal.fr Email: info@yvonbeal.fr
R.C.B 304 973 886 - SIREN 304 973 886

2502-098-1000-0

03-000167-050215

Directions for use of Parts Catalogue

1. Applicable model of machines

All component and option parts used for SL14H tractors are listed in this parts catalogue.

Description of type of machines and particulars

Type of Machines	Section	DESTINATION	Engine	
S L 14H	40 CE 20	GERMANY	FC420V - CB00	FC420V - FB00
	40 CE 40	U.K		
	40 CE 50	FRANCE		
	40 CE 50 T	ITALY		
	40 E 20	GERMANY		
	40 E 40	U.K		
	40 E 50	FRANCE		

Note : When you place an order for spare parts, please check and specify the Engine Model of your machine.

2. Explanation for head paragraph

KEY	PART CODE	DESCRIPTION	QTY	TYPE OF MODEL						I T C	C O L	G R P	REMARKS
				TF15	TF17	TF19							
126	1614-508-200-00	FILTER(SUCTION) ASSY	1	*	*						4E		
127	V721-103-103-50	O-RING	1	*	*								
128	1614-508-260-00	FILTER(SUCTION) ASSY	1	*	*	981- -1799							
129	1614-508-262-00	FILTER(LH) ASSY	1	*	*						4E	A	FIG. 164
			1	*	*	1- -1999				3			

- ① KEY shows the location of parts diagramed in the illustration.
- ② Parts numbers begin with `V` and `W` are standard parts of the market.
- ③ `LH` and `RH` on the parts name are described against the moving direction of the machine or are described on the condition how to install parts on the machines.

- ④ QTY shows the number of parts to be used for one unit of machine.
 `M` is indicated for parts supplied by a meter long.
 `ℓ` is indicated for parts supplied by liter.
 `AR` is indicated for parts need to be adjusted or regulated.
- ⑤ The following symbol classifies parts to be used for machines.
 `*` means standard parts.
 `T` shows that the parts can be installed as optional parts.
 `R` shows that the parts can be used as applicable parts to replace originally equipped parts.
- ⑥ Serial number : upper row shows the serial number for the first product and lower row for the last product.
 Example : Serial no. 1 through to serial no. 1999.
- ⑦ ITC : Interchangeability
 `1` ...OLD ← NEW
 New parts can be used in place of the old parts.
 `2` ...OLD → NEW
 Old parts can be used in place of the new parts.
 `3` ...OLD ↔ NEW
 Old parts and new parts can not be replaced each other.
- ⑧ COL : Color code
 Color is signified with color code number for colored parts.
 Please see the color list shown in the next page.
- ⑨ GRP : Parts shown in this column can be replaced by SET parts.
 Exsample : Parts marked ④ can be replaced by parts marked ③, and ① for ②, so the rest follow in the same alphabetical order.
- ⑩ Remarks
 * Other maker's part code number is shown in this column.
 * When Fig. No. is shown in the Remark column of SET parts or ASSY parts, each of their component parts are listed in said Fig. No.

3. Color :

The following colors are used for color parts.

COLOR CODE	COLOR	SPRAY TYPE CODE NUMBER	PAINTS 4K DRUM	PAINTS 16K DRUM
4 G	CRYSTAL BLUE	1300-957-001-10	1300-957-003-00	1300-957-004-00
6 G	SUMMER WHITE	1300-958-001-10	1300-958-003-00	1300-958-004-00
7 F	MIRROR BLACK	1300-954-001-10	1300-954-003-00	1300-954-004-00

NOTE : Color code is signified only for the parts assigned by the maker as color parts.

4. Serial Numbers :

- 1) For engines serial number is stamped on CYLINDER BODY ASSY.
Please see Fig. No. 1-14,15.
- 2) For chassies serial number is shown on the LABEL.
Please see



5. Parts Order

- 1) Parts numbers listed in the parts catalogue are all registered in "ISEKI on-line computer".
- 2) When you order parts, please make sure of correct numbers.
- 3) When substitute parts is available, the part number ordered will be automatically turned to a new part number.
- 4) Please be sure to use "ISEKI GENUINE PARTS".

Any other similar parts other than ISEKI parts when used may cause a trouble that makes us unable to repair or guarantee the warrant.

P. I *** STRUCTURE TABLE OF MODEL ***

F I G	M O D E L	S L										
		14444	444									
		40000	000									
		HCCCC	EEE									
		EEEE	245									
		2455	000									
		0000	T									
1	****	***										
2	****	***										
3	****	***										
4	****	***										
5	****	***										
6	****	***										
7	****	***										
8	****	***										
9	****	***										
10	****	***										
11	****	***										
12	****	***										
13	****	***										
14	****	***										
15	****	***										
16	****	***										
17	****	***										
18	****	***										
19	****	***										

www.emc-motoculture.com

CONTENTS

SL14H

ENGINE (FC420V-CB00)

(FC420V-FB00)

CYLINDER CRANKCASE	Fig. 1
PISTON CRANKSHAFT	Fig. 2
VALVE CAMSHAFT	Fig. 3
LUBRICATION EQUIPMENT	Fig. 4
COOLING EQUIPMENT	Fig. 5
ELECTRIC EQUIPMENT	Fig. 6
CONTROL EQUIPMENT	Fig. 7
CARBURETOR	Fig. 8
AIR FILTER MUFFLER	Fig. 9
FUEL TANK FUEL VALVE	Fig. 10
STARTER	Fig. 11
LABEL	Fig. 12
ACCESSORY	Fig. 13

www.emc-motoculture.com

CONTENTS

CHASSIS

SL14H

SHROUD AND FUEL TANK SYSTEM.....	Fig. 1
BATTERY SYSTEM.....	Fig. 2
THROTTLE SYSTEM.....	Fig. 3
BELT (DRIVING) AND HST SYSTEM.....	Fig. 4
PEDAL (HST) SYSTEM.....	Fig. 5
CASE (TRANSMISSION) SYSTEM.....	Fig. 6
BRAKE SYSTEM.....	Fig. 7
TIRE (REAR) SYSTEM.....	Fig. 8
CHASSIS SYSTEM.....	Fig. 9
AXLE (FRONT) SYSTEM.....	Fig. 10
STEERING SYSTEM.....	Fig. 11
TIRE (FRONT) SYSTEM.....	Fig. 12
P.T.O. SYSTEM.....	Fig. 13
LINK SYSTEM.....	Fig. 14
HOOD AND PANEL SYSTEM.....	Fig. 15
FENDER AND SEAT SYSTEM.....	Fig. 16
ELECTRICAL SYSTEM.....	Fig. 17
ORNAMENT.....	Fig. 18
LABEL.....	Fig. 19

SSM40

DRIVING SYSTEM.....	Fig. 20
DECK AND COVER SYSTEM.....	Fig. 21
LABEL.....	Fig. 22

SBC250

FAN AND COVER SYSTEM.....	Fig. 23
PANEL AND FRAME SYSTEM.....	Fig. 24
COVER AND PIPE SYSTEM.....	Fig. 25
LABEL.....	Fig. 26

ENGINE

FC420V - CB00

FC420V - FB00

www.emc-motoculture.com

FIG. 1 CYLINDER CRANKCASE

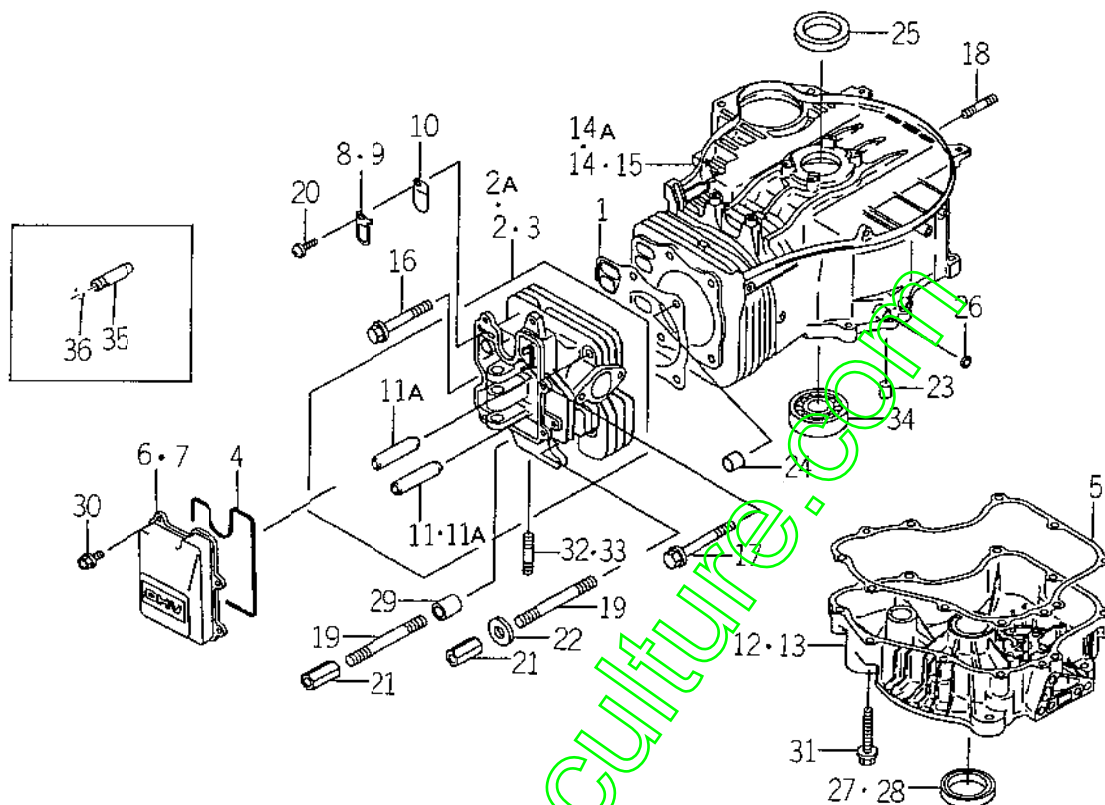

K392-0010

KEY	PART CODE	DESCRIPTION	QTY	TYPE OF MODEL		I T C	C O L	G R P	REMARKS
				FC420V CB00	FC420V FB00				
1	5110 - 042 - 096 - XX	GASKET - HEAD	1	*	*				110042096
2	5110 - 036 - 011 - XX	HEAD - COMP - CYLINDER	1	1- -119615					110086011
2A	5110 - 036 - 016 - XX	HEAD - COMP - CYLINDER	1	119616-					110086016
3	5110 - 086 - 026 - XX	HEAD - COMP - CYLINDER	1		*				110086026
4	5110 - 092 - 433 - XX	GASKET - ROCKER CASE	1	*	*				110092433
5	5110 - 092 - 947 - XX	GASKET - CRANKCASE	1	*	*				110092947
6	5110 - 222 - 055 - XX	CASE - ROCKER	1	*					110222055
7	5110 - 222 - 070 - XX	CASE - ROCKER	1		*				110222070
8	5131 - 692 - 436 - XX	PLATE	1	*					131692436
9	5132 - 702 - 055 - XX	PLATE	1		*				132702055
10	5161 - 262 - 113 - XX	VALVE	1	*	*				161262113
11	5490 - 022 - 078 - XX	GUIDE - VALV EX	1	1- -119615					490022078
11A	5490 - 022 - 107 - XX	GUIDE - VALVE	2	119616-	*				490022107
12	5490 - 156 - 028 - XX	COVER - CRANKCASE	1	*					490156028
13	5490 - 156 - 174 - XX	COVER - CRANKCASE	1		*				490156174
14	5491 - 206 - 019 - XX	CRANKCASE - COMP	1	1- -119615					491206019
14A	5491 - 206 - 061 - XX	CRANKCASE - COMP	1	119616-					491206061
15	5491 - 206 - 106 - XX	CRANKCASE - COMP	1		*				491206106
16	5920 - 022 - 273 - XX	BOLT	3	*	*				920022273
17	5920 - 022 - 310 - XX	BOLT	2	*	*				920022310
18	5920 - 042 - 083 - XX	STUD - 6X14	4	*	*				920042083
19	5920 - 042 - 094 - XX	STUD	2	*					920042094
20	5920 - 092 - 308 - XX	SCREW	1	*	*				920092308
21	5920 - 152 - 166 - XX	NUT	2	*					920152166
22	5920 - 222 - 206 - XX	WASHER - 10X20X2	1	*					920222206

FIG. 1 CYLINDER CRANKCASE

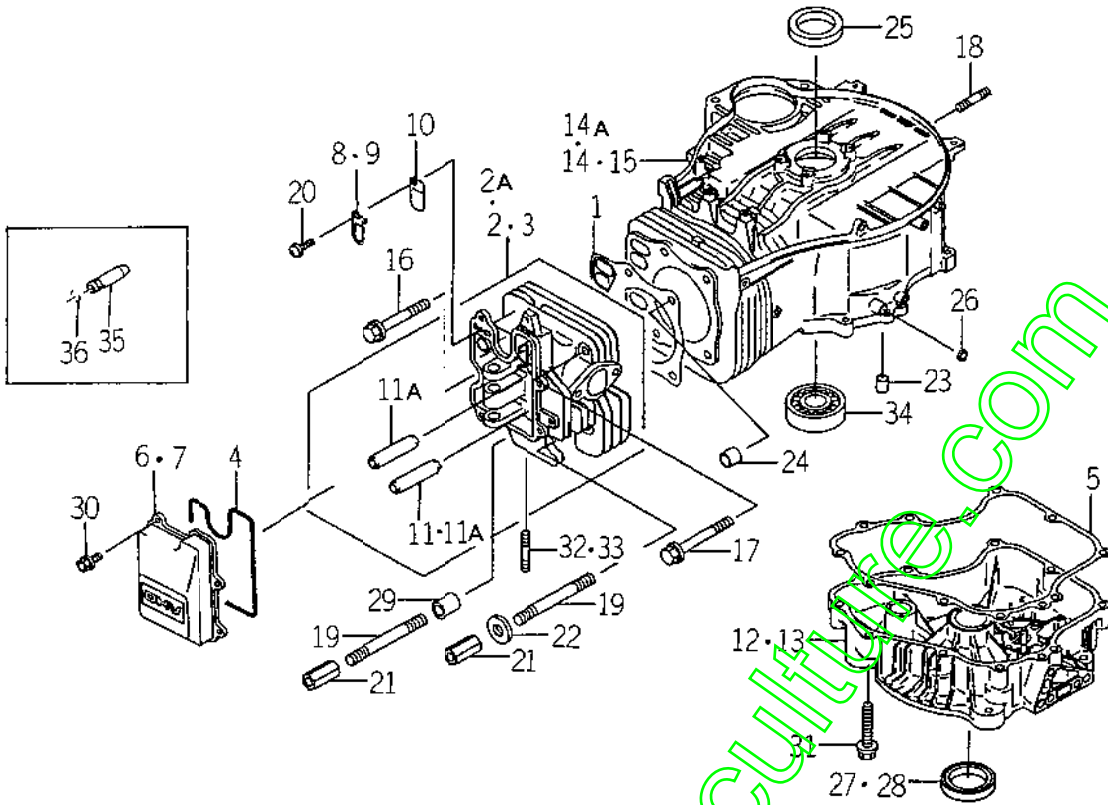

KE02-0010

KEY	PART CODE	DESCRIPTION	QTY	TYPE OF MODEL		I T C	C O L	G R P	REMARKS
				FC420V CB00	FC420V FB00				
23	5920 - 431 - 263 - XX	PIN	2	*	*				920431263
24	5920 - 431 - 266 - XX	PIN	2	*	*				920431266
25	5920 - 492 - 096 - XX	SEAL - OIL	1	*	*				920492096
26	5920 - 492 - 097 - XX	SEAL - OIL	1	*	*				920492097
27	5920 - 492 - 104 - XX	SEAL - OIL	1	*	*				920492104
28	5920 - 492 - 227 - XX	SEAL - OIL	1	*	*				920492227
29	5921 - 432 - 005 - XX	COLLAR	1	*	*				921432005
30	5130 - B06 - 14X - XX	BOLT - FLANGED	4	*	*				130B0614
31	5130 - T08 - 45X - XX	BOLT - FLANGED	9	*	*				130T0845
32	5171 - G08 - 18X - XX	BOLT - STUD	2	*	*				171G0818
33	5171 - G08 - 20X - XX	BOLT - STUD	2	*	*				171G0820
34	5601 - A63 - 07X - XX	BEARING - BALL	1	*	*				601A6307
35	5490 - 022 - 097 - XX	GUIDE, VALVE IN	1		1- 119815				49022097
36	5920 - 360 - 23X - XX	RING, SNAP	2		1- 119615				92036023

FIG. 2 PISTON CRANKSHAFT

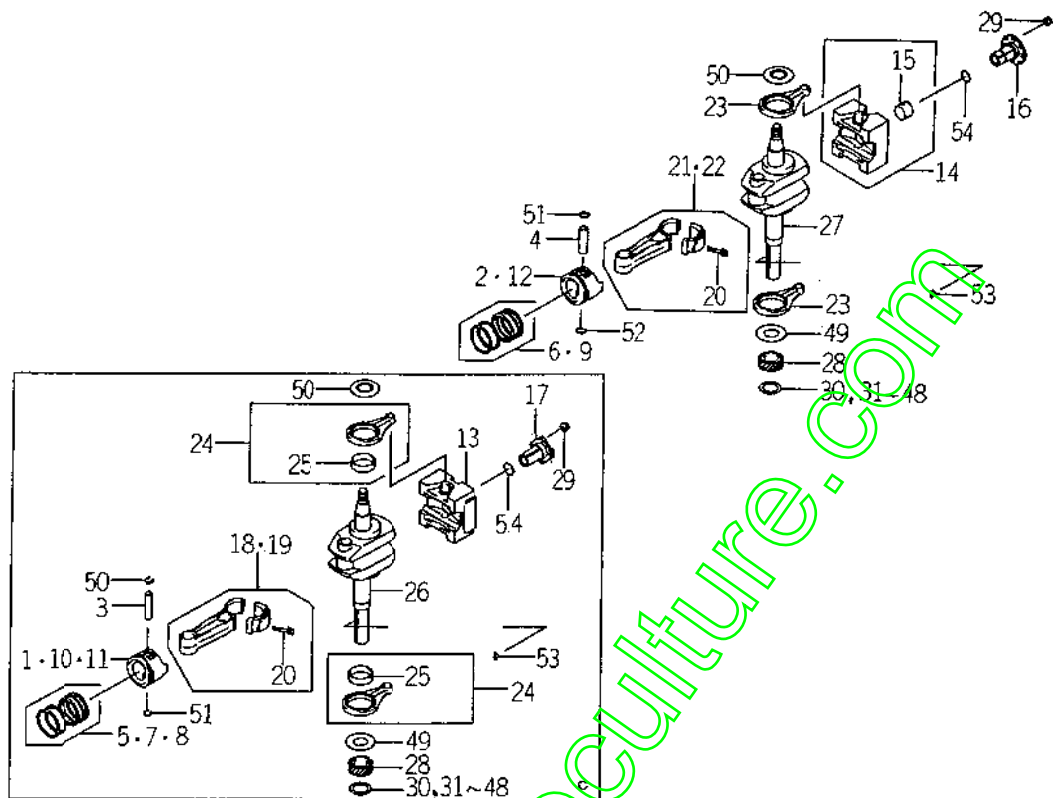

K502-0020

KEY	PART CODE	DESCRIPTION	QTY	TYPE OF MODEL		I T C	C O L	G R P	REMARKS
				FC420V CB00	FC420V FB00				
1	5130-012-092-XX	PISTON - ENGINE	1	*					130012092
2	5130-012-130-XX	PISTON - ENGINE	1		*				130012130
3	5130-022-070-XX	PIN - PISTON	1	*					130022070
4	5130-022-078-XX	PIN - PISTON	1		*				130022078
5	5130-086-001-XX	RING - SET - PISTON	1	*					130086001
6	5130-086-053-XX	RING - SET - PISTON	1		*				130086053
7	5130-086-002-XX	RING - SET - PISTONL	AR	*					130086002
8	5130-086-003-XX	RING - SET - PISTONL	AR	*					130086003
9	5130-256-020-XX	RING - SET - PISTONL	AR		*				130256020
10	5130-292-078-XX	PISTON - ENGINE L - 0.25	AR	*					130292078
11	5130-292-079-XX	PISTON - ENGINE L - 0.50	AR	*					130292079
12	5130-292-106-XX	PISTON - ENGINE L - 0.50	AR		*				130292106
13	5130-426-008-XX	WEIGHT	1	*					130426008
14	5130-426-010-XX	WEIGHT	1		*				130426010
15	5921-412-112-XX	BEARING - PLANE	1		*				921412112
16	5131-072-088-XX	SHAFT	1		*				131072088
17	5131-072-232-XX	SHAFT	1	*					131072232
18	5132-516-019-XX	ROD - ASSY - CONNECTING	1	*					132516019
19	5132-516-020-XX	ROD - ASSY - CONNECTING	AR	*					132516020
20	5921-502-193-XX	BOLT	2	*	*				921502193
21	5132-516-039-XX	ROD - ASSY - CONNECTING	1		*				132516039
22	5132-516-041-XX	ROD - ASSY - CONNECTING	AR		*				132516041
23	5461-022-077-XX	ROD	2		*				461022077
24	5461-026-007-XX	ROD	2	*					461026007
25	5921-412-108-XX	BEARING - PLANE	2	*					921412108

FIG. 2 PISTON CRANKSHAFT

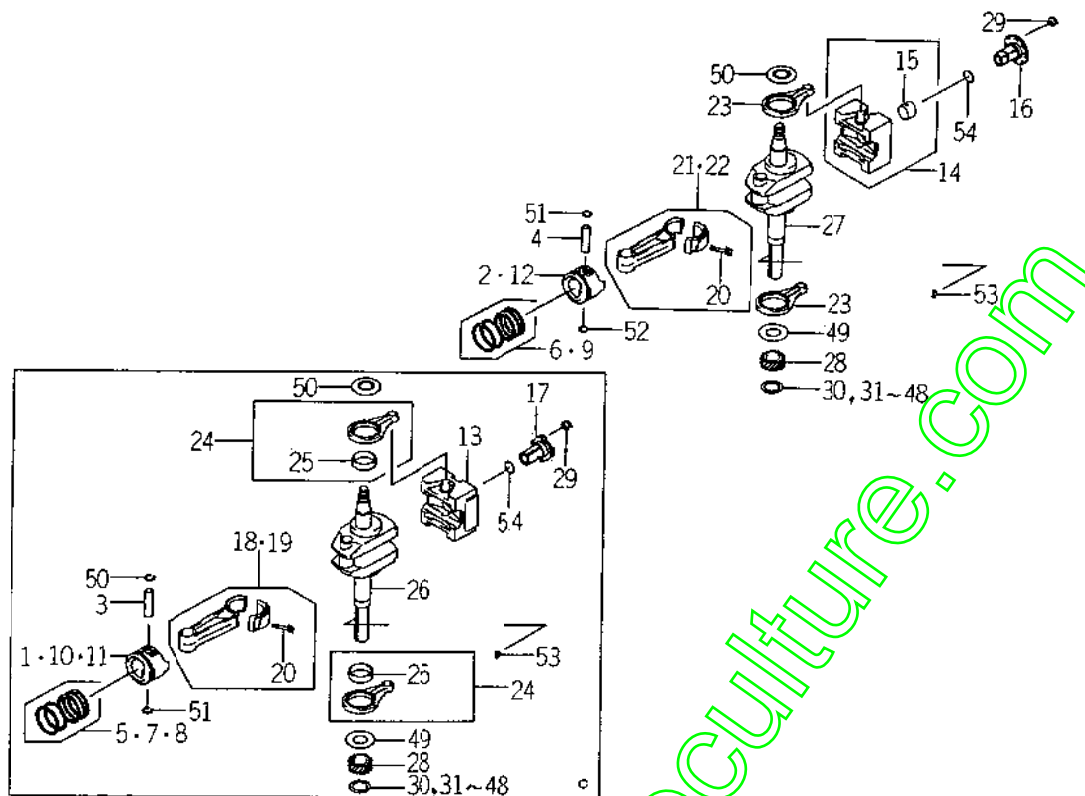

1502-0020

KEY	PART CODE	DESCRIPTION	QTY	TYPE OF MODEL		I T C	C O L	G R P	REMARKS
				FC420V CB00	FC420V FB00				
26	5491 - 192 - 134 - XX	CRANKSHAFT - ASSY	1	*	*				491192134
27	5491 - 192 - 179 - XX	CRANKSHAFT - ASSY	1		*				491192179
28	5590 - 562 - 101 - XX	GEAR - HELICAL	1	*	*				590562101
29	5920 - 151 - 193 - XX	NUT	4	*	*				920151193
30	5920 - 252 - 210 - XX	SHIM,1.18	AR	*	*				920252210
31	5920 - 252 - 211 - XX	SHIM,T = 1.215	AR	*	*				920252211
32	5920 - 252 - 212 - XX	SHIM,T = 1.25	AR	*	*				920252212
33	5920 - 252 - 213 - XX	SHIM,T = 1.285	AR	*	*				920252213
34	5920 - 252 - 214 - XX	SHIM,T = 1.32	AR	*	*				920252214
35	5920 - 252 - 215 - XX	SHIM,T = 1.355	AR	*	*				920252215
36	5920 - 252 - 216 - XX	SHIM,T = 1.39	AR	*	*				920252216
37	5920 - 252 - 217 - XX	SHIM,T = 1.425	AR	*	*				920252217
38	5920 - 252 - 218 - XX	SHIM,T = 1.46	AR	*	*				920252218
39	5920 - 252 - 219 - XX	SHIM,T = 1.495	AR	*	*				920252219
40	5920 - 252 - 220 - XX	SHIM,T = 1.53	AR	*	*				920252220
41	5920 - 252 - 221 - XX	SHIM,T = 1.565	AR	*	*				920252221
42	5920 - 252 - 222 - XX	SHIM,T = 1.60	AR	*	*				920252222
43	5920 - 252 - 223 - XX	SHIM,T = 1.635	AR	*	*				920252223
44	5920 - 252 - 224 - XX	SHIM,T = 1.67	AR	*	*				920252224
45	5920 - 252 - 225 - XX	SHIM,T = 1.705	AR	*	*				920252225
46	5920 - 252 - 226 - XX	SHIM,T = 1.74	AR	*	*				920252226
47	5920 - 252 - 227 - XX	SHIM,T = 1.775	AR	*	*				920252227
48	5920 - 252 - 228 - XX	SHIM,T = 1.81	AR	*	*				920252228
49	5920 - 262 - 156 - XX	SPACER	1	*	*				920262156
50	5920 - 262 - 160 - XX	SPACER	1	*	*				920262160

FIG. 3 VALVE CAMSHAFT

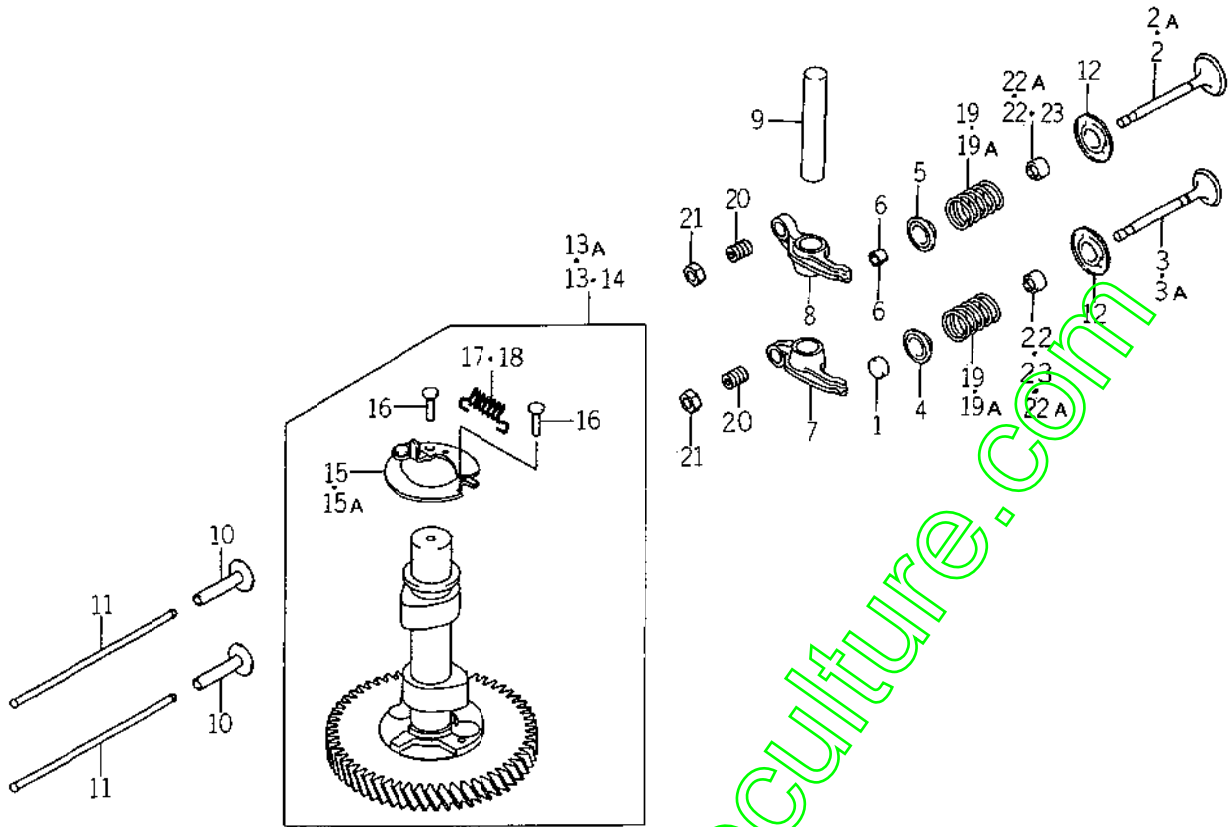

X502-003C

KEY	PART CODE	DESCRIPTION	QTY	TYPE OF MODEL		I T C	C O L	G R P	REMARKS
				FC420V CB00	FC420V FB00				
1	5110 - 122 - 189 - XX	CAP, VALVE	1	*					110122189
2	5120 - 042 - 085 - XX	VALVE - INTAKE	1		1- -119615				120042085
2A	5120 - 042 - 097 - XX	VALVE - INTAKE	1		119616-				120042097
3	5120 - 052 - 070 - XX	VALVE - EXHAUST	1		1- -119615				120052070
3A	5120 - 052 - 086 - XX	VALVE - EXHAUST	1		119616-			*	120052086
4	5120 - 092 - 058 - XX	RETAINER - VALVE	1	*	*				120092058
5	5120 - 092 - 060 - XX	RETAINER - VALVE	1	*	*				120092060
6	5120 - 112 - 052 - XX	COLLET	2	*	*				120112052
7	5120 - 162 - 054 - XX	ARM - ROCKER	1	*	*				120162054
8	5120 - 162 - 055 - XX	ARM - ROCKER	1	*	*				120162055
9	5120 - 202 - 058 - XX	SHAFT - ROCKER	1	*	*				120202058
10	5120 - 322 - 068 - XX	TAPPET	2	*	*				120322068
11	5131 - 162 - 056 - XX	ROD - PUSH	2	*	*				131162056
12	5160 - 072 - 052 - XX	SEAT - SPRING	2	*	*				160072052
13	5491 - 182 - 077 - XX	CAMSHAFT - COMP	1		1- -119615				491182077
13A	5491 - 182 - 099 - XX	CAMSHAFT - COMP	1		119616-				491182099
14	5491 - 182 - 132 - XX	CAMSHAFT - COMP	1		*				491182132
15	5211 - 182 - 077 - XX	DECOMPRESSOR	1		1- -119615				211182077
15A	5211 - 182 - 083 - XX	DECOMPRESSOR	1		119616-			*	211182083
16	5920 - 432 - 113 - XX	PIN	2	*	*				920432113
17	5920 - 812 - 033 - XX	SPRING	2	*	*				920812033
18	5921 - 442 - 323 - XX	SPRING	1	*	*				921442323
19	5490 - 782 - 061 - XX	SPRING - ENGINE VALVE	2		1- -119615				490782061
19A	5490 - 782 - 068 - XX	SPRING - ENGINE VALVE	2		119616-			*	490782068
20	5920 - 092 - 182 - XX	SCREW	2	*	*				920092182

FIG. 4 LUBRICATION EQUIPMENT

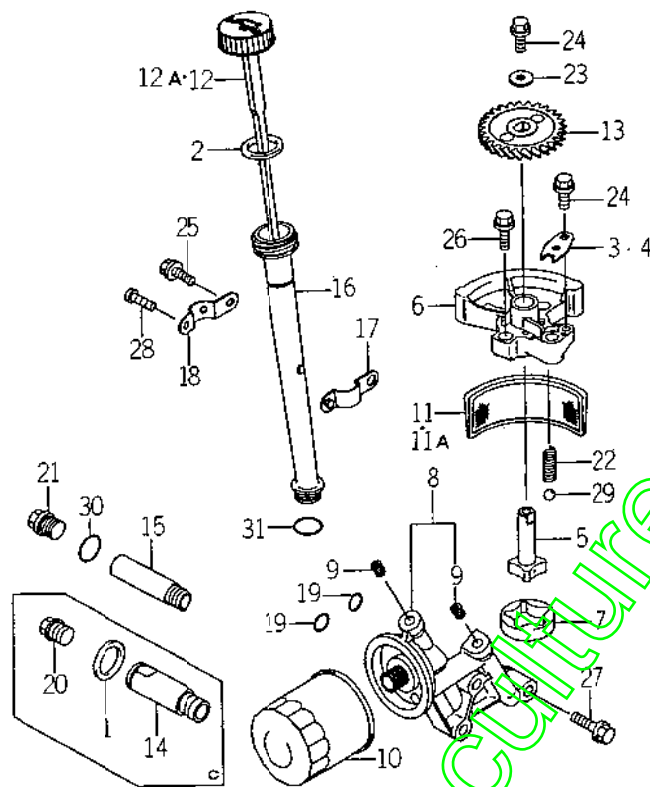

K502-0040

KEY	PART CODE	DESCRIPTION	QTY	TYPE OF MODEL		I T C	C O L	G R P	REMARKS
				FC420V CB00	FC420V FB00				
1	5110 - 092 - 175 - XX	GASKET	1	*	*				110092175
2	5110 - 092 - 346 - XX	GASKET,OIL GAUGE	1	*	*				110092346
3	5131 - 692 - 360 - XX	PLATE	1	*	*				131692360
4	5132 - 702 - 054 - XX	PLATE	1	*	*				132702054
5	5160 - 822 - 059 - XX	PUMP - ASSY - OIL	1	*	*				160822059
6	5161 - 422 - 053 - XX	COVER - PUMP	1	*	*				161422053
7	5161 - 542 - 052 - XX	ROTOR - PUMP	1	*	*				161542052
8	5310 - 646 - 001 - XX	PIPE - COMP	1	*	*				310646001
9	5920 - 662 - 211 - XX	PLUG	2	*	*				920662211
10	5490 - 652 - 071 - XX	FILTER - OIL	1	*	*				490652071
11	5490 - 652 - 059 - XX	FILTER - OIL	1	1- -119615 119616-	*				490652059
11A	5490 - 652 - 073 - XX	FILTER - OIL	1	1- -119615 119616-	*				490652073
12	5520 - 052 - 070 - XX	GAUGE	1	1- -119615 119616-	*				520052070
12A	5520 - 052 - 105 - XX	GAUGE	1	1- -119615 119616-	*				520052105
13	5590 - 562 - 090 - XX	GEAR - HERICAL	1	*	*				590562090
14	5590 - 712 - 070 - XX	JOINT	1	*	*				590712070
15	5590 - 712 - 114 - XX	JOINT	1	*	*				590712114
16	5592 - 312 - 062 - XX	FILLER	1	*	*				592312062
17	5920 - 372 - 199 - XX	CLAMP	1	*	*				920372199
18	5920 - 372 - 200 - XX	CLAMP	1	*	*				920372200
19	5920 - 552 - 073 - XX	RING - O	2	*	*				920552073
20	5920 - 662 - 092 - XX	PLUG,DRAIN	1	*	*				920662092
21	5920 - 662 - 207 - XX	PLUG	1	*	*				920662207
22	5920 - 812 - 305 - XX	SPRING	1	*	*				920812305
23	5922 - 002 - 035 - XX	WASHER	1	*	*				922002035

FIG. 5 COOLING EQUIPMENT

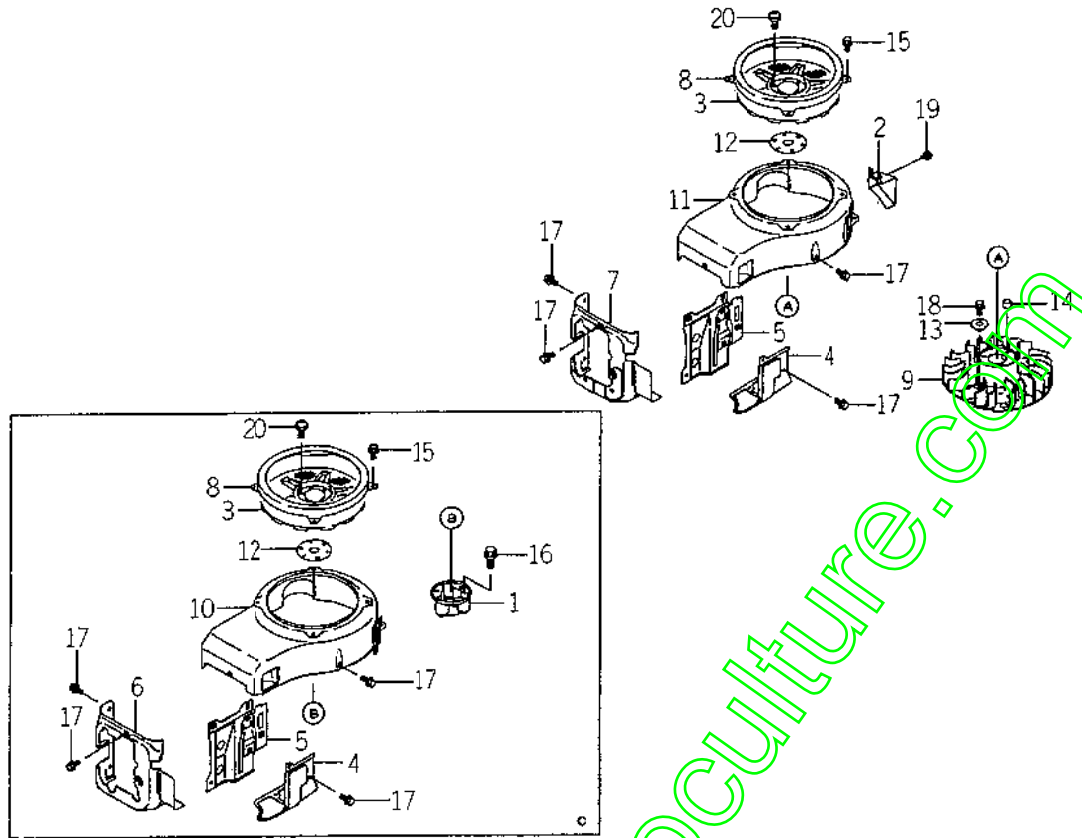

2302-005G

KEY	PART CODE	DESCRIPTION	QTY	TYPE OF MODEL		I T C	C O L	G R P	REMARKS
				FC420V CB00	FC420V FB00				
1	5110 - 442 - 084 - XX	BRACKET	1	*					110442084
2	5140 - 242 - 294 - 9H	COVER	1		*				1402422949H
3	5140 - 372 - 104 - 9H	SCREEN	1	*	*				1403721049H
4	5490 - 892 - 232 - 9H	SHROUD - ENGINE	1	*	*				4908922329H
5	5490 - 892 - 233 - 9H	SHROUD - ENGINE	1	*	*				4908922339H
6	5490 - 892 - 330 - 9H	SHROUD - ENGINE	1	*					4908923309H
7	5490 - 892 - 392 - 9H	SHROUD - ENGINE	1		*				4908923929H
8	5550 - 202 - 079 - 9H	GUARD	1	*	*				5502020799H
9	5590 - 412 - 087 - XX	FAN	1		*				590412087
10	5590 - 662 - 431 - 9H	HOUSING - FAN	1	*					5906624319H
11	5590 - 662 - 564 - 9H	HOUSING - FAN	1		*				5906625649H
12	5920 - 252 - 003 - XX	SHIM, T = 1.20	AR	*	*				920252003
13	5921 - 432 - 179 - XX	COLLAR	4		*				921432179
14	5921 - 432 - 182 - XX	COLLAR, 6.2x7.8x5	3		*				921432182
15	5130 - B06 - 10X - XX	BOLT - FLANGED	4	*	*				130B0610
16	5130 - B08 - 20X - XX	BOLT - FLANGED	3	*					130B0820
17	5130 - G06 - 12X - XX	BOLT - FLANGED	12	*	*				130G0612
18	5130 - G06 - 14X - XX	BOLT - FLANGED	4		*				130G0614
19	5224 - B04 - 08X - XX	SCREW - PAN - WP - CROS	2		*				224B0408
20	5224 - B06 - 16X - XX	SCREW - PAN - WP - CROS	3	*	*				224B0616

FIG. 6 ELECTRIC EQUIPMENT

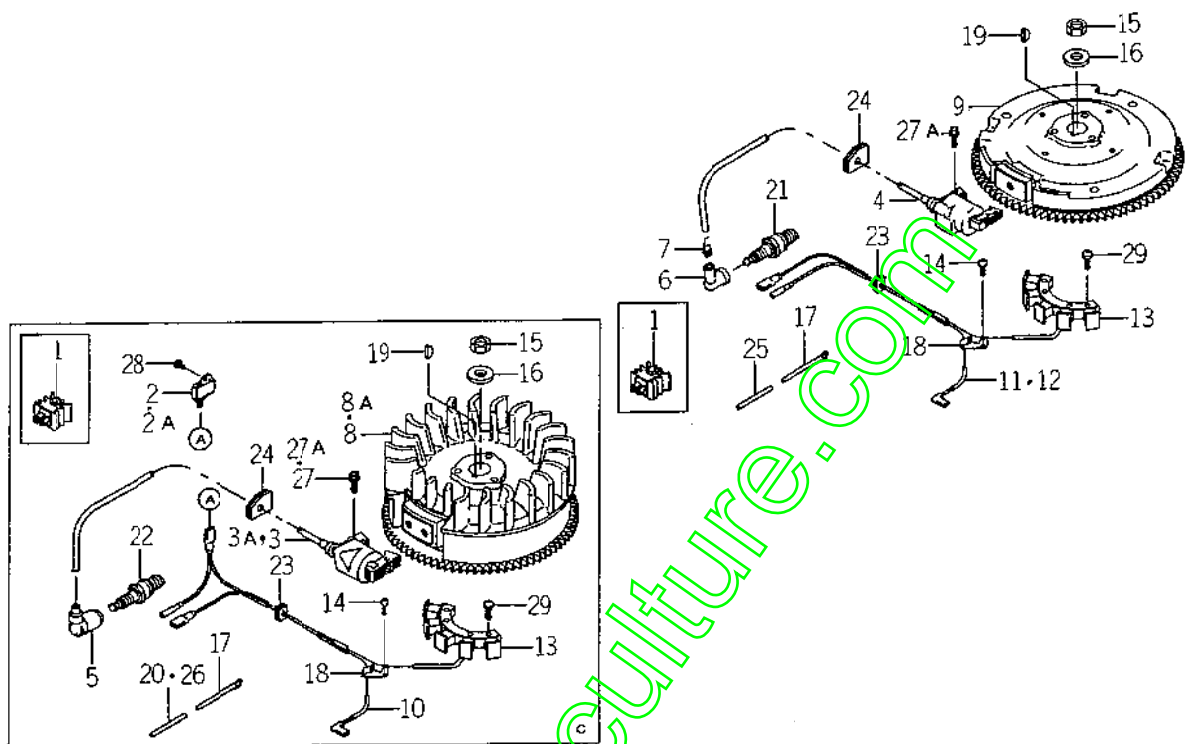

K502-0060

KEY	PART CODE	DESCRIPTION	QTY	TYPE OF MODEL		I T C	C O L	G R P	REMARKS
				FC420V CB00	FC420V FB00				
1	5210 - 661 - 020 - XX	REGULATOR - VOLTAGE	1	*	*				210661020
2	5211 - 192 - 095 - XX	IGNITER	1	1- -119615					211192095
2A	5211 - 192 - 101 - XX	IGNITER	1	119616-					211192101
3	5211 - 212 - 008 - XX	COIL - IGNITION	1	1- -119615					211212008
3A	5211 - 212 - 070 - XX	COIL - IGNITION	1	119616-					211212070
4	5211 - 212 - 086 - XX	COIL - IGNITION	1		*				211212086
5	5211 - 302 - 060 - XX	CAP - SPARK PLUG	1	*					211302060
6	5211 - 302 - 066 - XX	CAP - SPARK PLUG	1		*				211302066
7	5211 - 692 - 004 - XX	TERMINAL	1		*				211692004
8	5211 - 932 - 072 - XX	FLYWHEEL - ASSY	1	1- -119615					211932072
8A	5211 - 932 - 126 - XX	FLYWHEEL - ASSY	1	119616-					211932126
9	5211 - 932 - 154 - XX	FLYWHEEL - ASSY	1		*				211932154
10	5260 - 112 - 104 - XX	WIRE - LEAD	1	*					260112104
11	5260 - 112 - 314 - XX	WIRE - LEAD	1		1- B52571				260112314
12	5260 - 112 - 331 - XX	WIRE - LEAD, L = 260	1		*				260112331
13	5590 - 312 - 086 - XX	COIL - CHARGING	1	*	*				590312086
14	5920 - 092 - 308 - XX	SCREW	1	*	*				920092308
15	5920 - 152 - 167 - XX	NUT	1	*	*				920152167
16	5920 - 222 - 229 - XX	WASHER	1	*	*				920222229
17	5920 - 372 - 063 - XX	CLAMP	1	*	*				920372063
18	5920 - 372 - 177 - XX	CLAMP	1	*	*				920372177
19	5920 - 382 - 094 - XX	KEY	1	*	*				920382094
20	5920 - 592 - 012 - XX	TUBE, 5X6X55	1	*					920592012
21	5920 - 702 - 075 - XX	PLUG - SPARK, RN11YC	1		*				920702075
22	5920 - 702 - 077 - XX	PLUG - SPARK, BPR5E5	1	*					920702077

FIG. 7 CONTROL EQUIPMENT

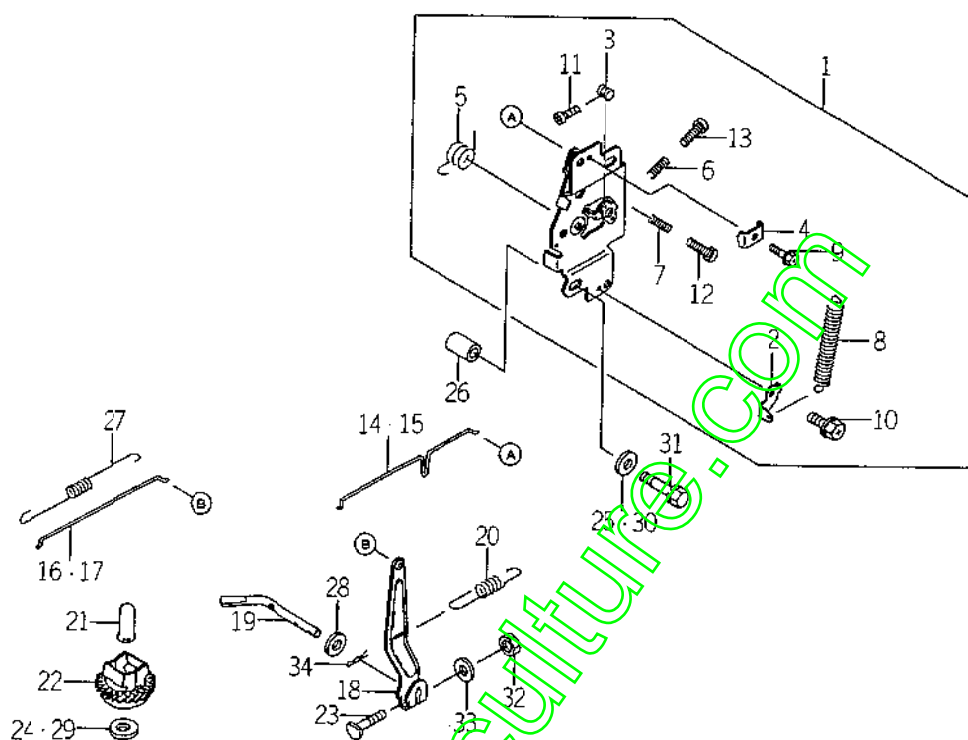

K562-0076

KEY	PART CODE	DESCRIPTION	QTY	TYPE OF MODEL		I T C	C O L	G R P	REMARKS
				FC420V CB00	FC420V FB00				
1	5491 - 132 - 098 - XX	PANEL - COMP - CONTROL	1	*	*				491132098
2	5110 - 472 - 028 - XX	BRACKET	1	*	*				110472028
3	5920 - 152 - 120 - XX	NUT	1	*	*				920152120
4	5920 - 372 - 020 - XX	CLAMP	1	*	*				920372020
5	5920 - 812 - 316 - XX	SPRING	1	*	*				920812316
6	5921 - 442 - 220 - XX	SPRING	1	*	*				921442220
7	5921 - 442 - 266 - XX	SPRING	1	*	*				921442266
8	5921 - 442 - 281 - XX	SPRING	1	*	*				921442281
9	5921 - 502 - 182 - XX	BOLT,5X18	1	*	*				921502182
10	5130 - B05 - 08X - XX	BOLT - FLANGED	1	*	*				130B0508
11	5214 - B04 - 12X - XX	SCREW - PAN	1	*	*				214B0412
12	5214 - B04 - 20X - XX	SCREW - PAN	1	*	*				214B0420
13	5214 - B04 - 25X - XX	SCREW - PAN	1	*	*				214B0425
14	5161 - 692 - 088 - XX	LINK - CHOKE	1	*	*				161692088
15	5161 - 692 - 130 - XX	LINK - CHOKE	1	*	*				161692130
16	5161 - 712 - 056 - XX	LINK,GOVERNOR	1	*	*				161712056
17	5161 - 712 - 079 - XX	LINK,GOVERNOR	1	*	*				161712079
18	5211 - 872 - 055 - XX	ARM - ASSY	1	*	*				211872055
19	5390 - 032 - 073 - XX	ARM - PIVOT	1	*	*				390032073
20	5391 - 292 - 011 - XX	SPRING - GOVERNOR	1	*	*				391292011
21	5420 - 362 - 060 - XX	SLEEVE	1	*	*				420362060
22	5491 - 102 - 067 - XX	GOVERNOR - ASSY	1	*	*				491102067
23	5920 - 022 - 269 - XX	BOLT	1	*	*				920022269
24	5920 - 222 - 019 - XX	WASHER (148906)	1	*	*				920222019
25	5920 - 222 - 089 - XX	WASHER	1	*	*				920222089

FIG. 8 CARBURETOR

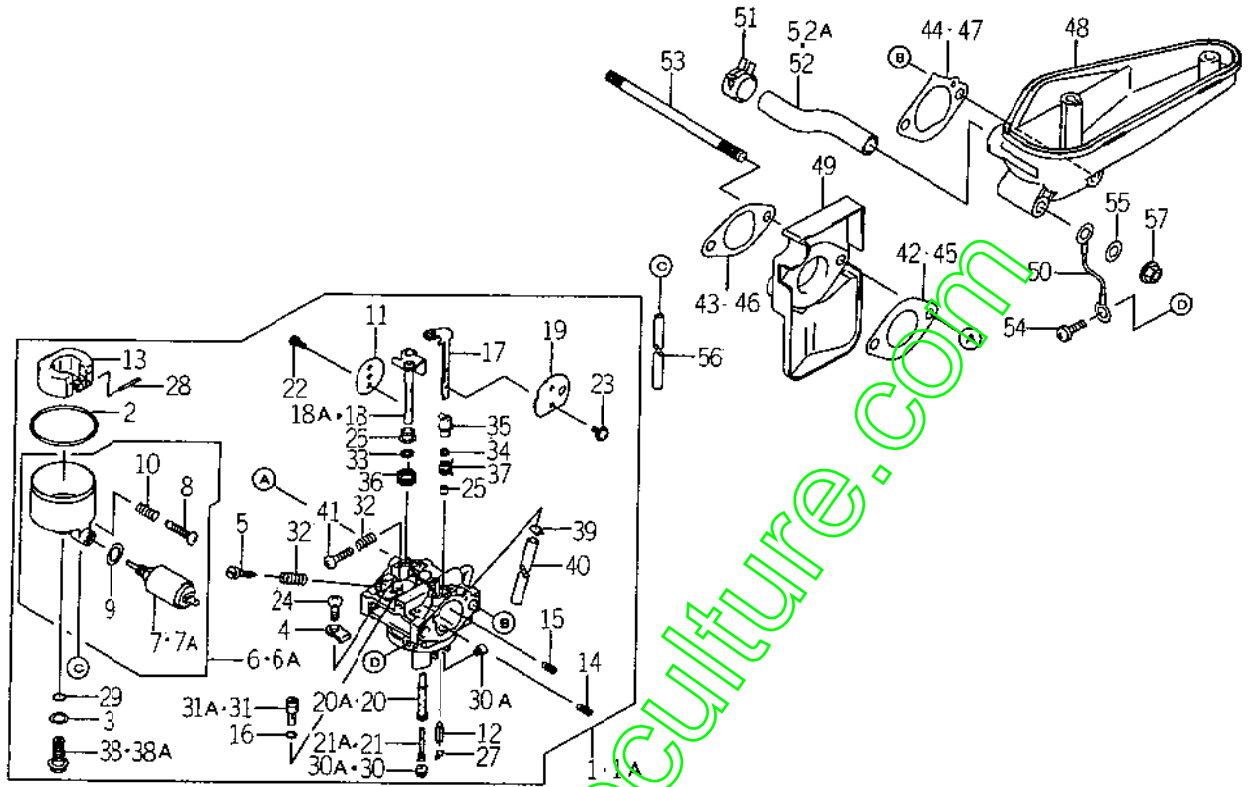

K502-C080

KEY	PART CODE	DESCRIPTION	QTY	TYPE OF MODEL		I T C	C O L	G R P	REMARKS
				FC420V CB00	FC420V FB00				
1	5150 - 032 - 090 - XX	CARBURETOR - ASSY	1	1- -119615					150032090
1A	5150 - 032 - 164 - XX	CARBURETOR - ASSY	1	119616-	*				150032164
2	5110 - 092 - 024 - XX	GASKET	1	*	*				110092024
3	5110 - 092 - 769 - XX	GASKET	1	*	*				110092769
4	5131 - 832 - 252 - XX	PLATE	1	*	*				131832252
5	5160 - 142 - 010 - XX	SCREW - PILOT AIR	1	*	*				160142010
6	5160 - 202 - 096 - XX	CHAMBER - FLOAT	1	1- -119615					160202096
6A	5160 - 202 - 122 - XX	CHAMBER - FLOAT	1	119616-	*				160202122
7	5211 - 882 - 001 - XX	SOLENOID, CARBURETOR	1	1- -119615					211882001
7A	5211 - 882 - 004 - XX	SOLENOID, CARBURETOR	1	119616-	*				211882004
8	5920 - 092 - 025 - XX	SCREW	1	*	*				920092025
9	5920 - 650 - 787 - XX	WASHER	1	*	*				92065078
10	5921 - 442 - 174 - XX	SPRING	1	*	*				921442174
11	5160 - 252 - 137 - XX	VALVE - THROTTLE 90	1	*	*				160252137
12	5160 - 302 - 067 - XX	VALVE - FLOAT	1	*	*				160302067
13	5160 - 312 - 063 - XX	FLOAT	1	*	*				160312063
14	5160 - 352 - 053 - XX	JET - AIR 1.8	1	*	*				160352056
15	5160 - 352 - 053 - XX	JET - AIR 1.1	1	*	*				160352058
16	5160 - 380 - 24X - XX	GASKET	1	*	*				16038024
17	5160 - 412 - 163 - XX	SHAFT - CARBURETOR	1	*	*				160412163
18	5160 - 412 - 163 - XX	SHAFT - CARBURETOR	1	1- -119615					160412163
18A	5160 - 412 - 215 - XX	SHAFT - CARBURETOR	1	119616-	*				160412215
19	5161 - 262 - 151 - XX	VALVE, CHOKE	1	*	*				161262151
20	5491 - 212 - 106 - XX	NOZZLE - MAIN 65A	1	1- -119615					491212106
20A	5491 - 212 - 152 - XX	NOZZLE - MAIN 65A	1	119616-	*				491212152

FIG. 8 CARBURETOR

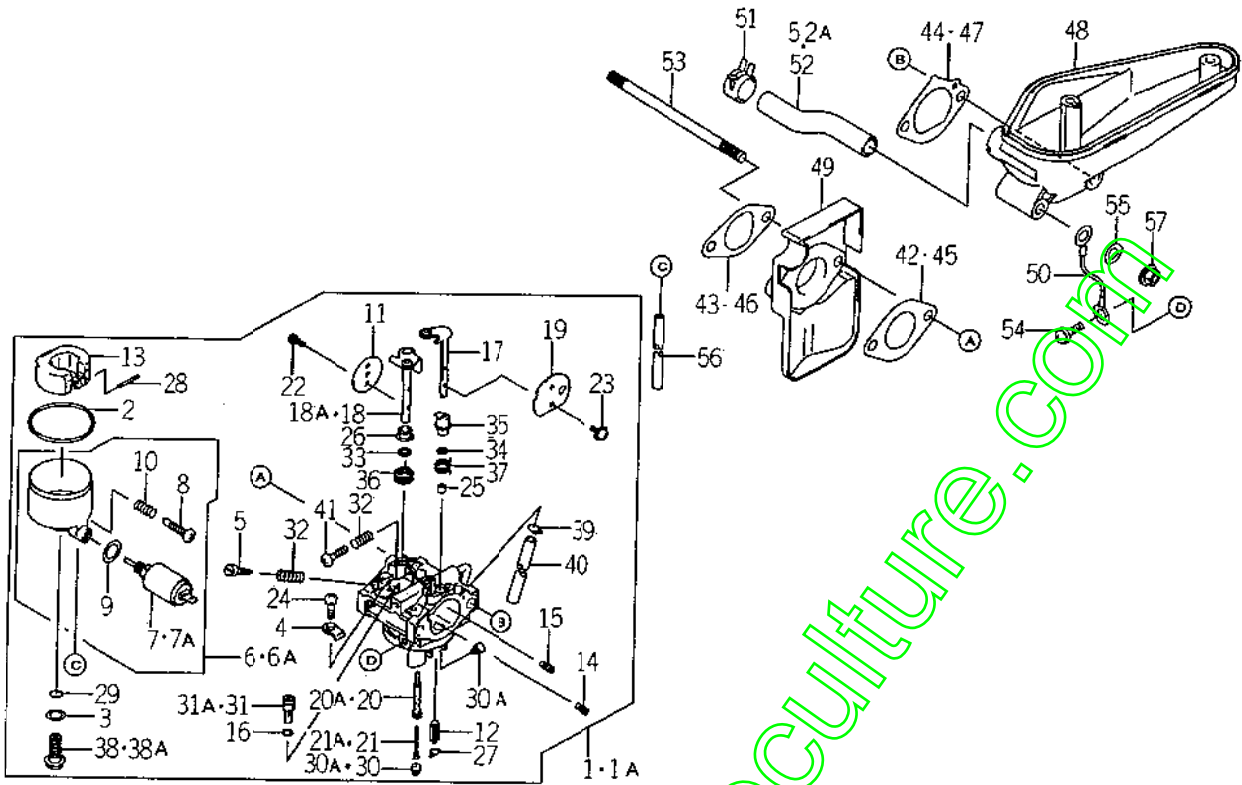

X502-0086

KEY	PART CODE	DESCRIPTION	QTY	TYPE OF MODEL		I T C	C O L	G R P	REMARKS
				FC420V CB00	FC420V FB00				
21	5491 - 232 - 005 - XX	HOLDER - MAIN JET	1	1- -119615					491232058
21A	5491 - 232 - 068 - XX	HOLDER - MAIN JET	1	119616-	*				491232068
22	5920 - 092 - 080 - XX	SCREW	2	*	*				920092080
23	5920 - 092 - 081 - XX	SCREW	2	*	*				920092081
24	5920 - 092 - 244 - XX	SCREW	1	*	*				920092244
25	5920 - 272 - 003 - XX	COLLAR	1	*	*				920272003
26	5920 - 272 - 025 - XX	COLLAR	1	*	*				920272025
27	5920 - 332 - 067 - XX	RING - SNAP	1	*	*				920332067
28	5920 - 432 - 006 - XX	PIN	1	*	*				920432006
29	5920 - 552 - 148 - XX	O RING	1	*	*				920552148
30	5920 - 632 - 149 - XX	JET - MAIN 97.5	1	1- -119615					920632149
30A	5920 - 632 - 197 - XX	JET - MAIN 97.5	1	119616-	*				920632197
31	5920 - 642 - 062 - XX	JET - PILOT 60	1	1- -119615					920642062
31A	5920 - 642 - 079 - XX	JET - PILOT 60	1	119616-	*				920642079
32	5920 - 812 - 009 - XX	SPRING	2	*	*				920812009
33	5920 - 932 - 002 - XX	SEAL	1	*	*				920932002
34	5920 - 932 - 069 - XX	SEAL	1	*	*				920932069
35	5921 - 432 - 142 - XX	COLLAR	1	*	*				921432142
36	5921 - 442 - 037 - XX	SPRING	1	*	*				921442037
37	5921 - 442 - 160 - XX	SPRING	1	*	*				921442160
38	5921 - 502 - 121 - XX	BOLT	1	1- -119615					921502121
38A	5921 - 502 - 218 - XX	BOLT	1	119616-	*				921502218
39	5921 - 702 - 023 - XX	CLAMP	1	*	*				921702023
40	5921 - 902 - 011 - XX	TUBE,4.5X6.5X100	1	*	*				921902011
41	5214 - B04 - 14X - XX	SCREW - PAN	1	*	*				214B0414

FIG. 8 CARBURETOR

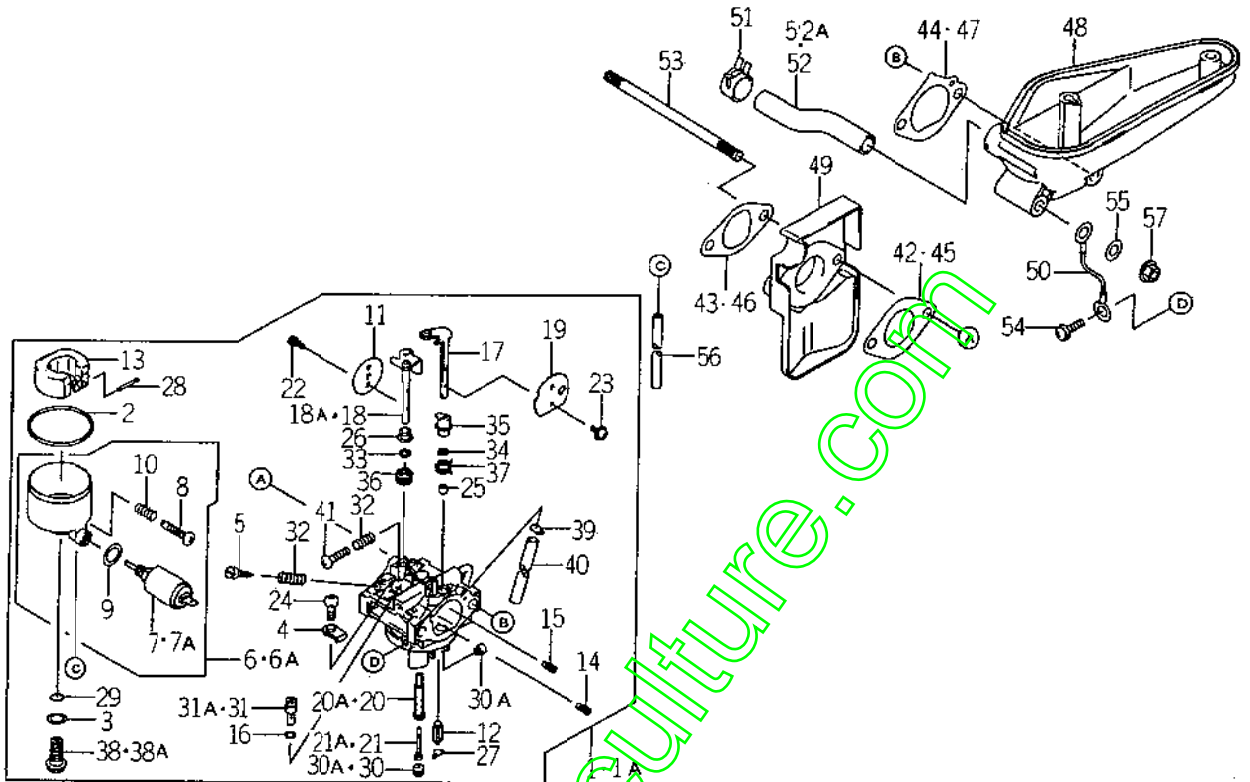

K502-0080

KEY	PART CODE	DESCRIPTION	QTY	TYPE OF MODEL		I T C	C O L	G R P	REMARKS
				FC420V CB00	FC420V FB00				
42	5110 - 092 - 944 - XX	GASKET,CARBURETOR	1	*					110092944
43	5110 - 092 - 945 - XX	GASKET,INSULATOR	1	*					110092945
44	5110 - 092 - 946 - XX	GASKET,INTAKE PIPE	1	*					110092946
45	5110 - 602 - 339 - XX	GASKET,CARBURETOR	1		*				110602339
46	5110 - 602 - 340 - XX	GASKET,INSULATOR	1		*				110602340
47	5110 - 602 - 341 - XX	GASKET,INTAKE PIPE	1		*				110602341
48	5160 - 606 - 001 - XX	PIPE - INTAKE	1	*	*				160606001
49	5160 - 736 - 001 - XX	INSULATOR	1	*	*				160736001
50	5260 - 112 - 233 - XX	WIRE - LEAD	1	*	*				260112233
51	5920 - 372 - 012 - XX	CLAMP	1	*	*				920372012
52	5920 - 592 - 226 - XX	TUBE,11.6X16X116	1		1- -119615				920592226
52A	5921 - 902 - 066 - XX	TUBE,11.6X16X116	1		119616-				921902066
53	5172 - G06 - 115 - XX	BOLT - STUD	2	*	*				172G06115
54	5224 - B05 - 08X - XX	SCREW - PAN - WP - CROS	1	*	*				224B0508
55	5410 - B06 - 00X - XX	W - PLAIN - S	1	*	*				410B0600
56	5702 - A04 - 100 - 0X	TUBE - RUBBER	1	*	*				702A041000
57	5920 - 151 - 193 - XX	NUT	2	*	*				920151193

FIG. 9 AIR FILTER MUFFLER

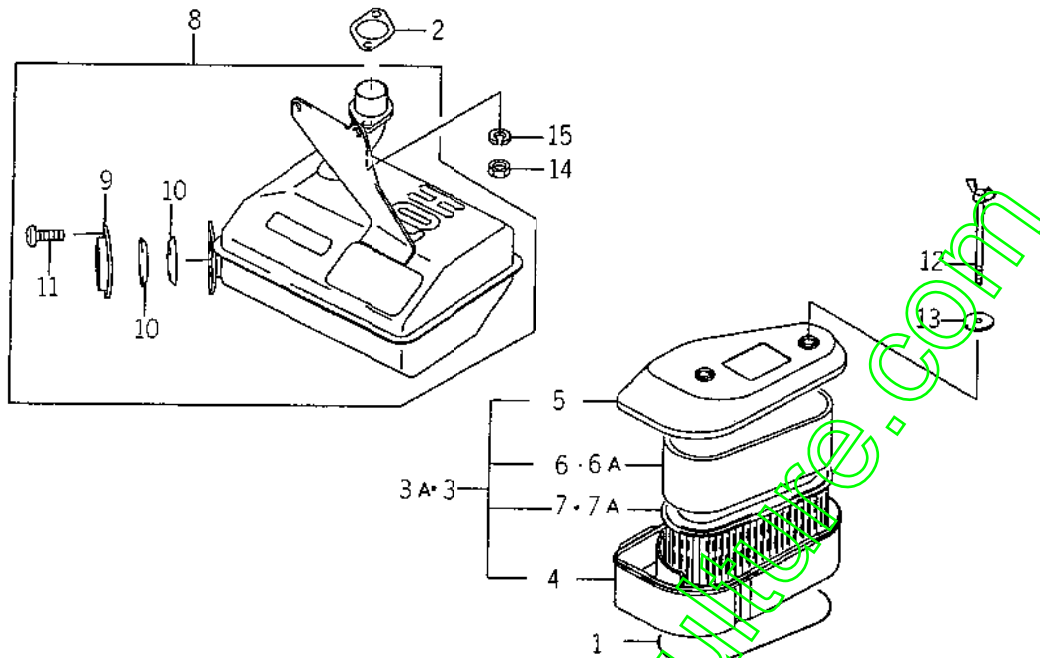

KAC2-0098

KEY	PART CODE	DESCRIPTION	QTY	TYPE OF MODEL		I T C	C O L	G R P	REMARKS
				FC420V CB00	FC420V FB00				
1	5110 - 092 - 505 - XX	GASKET, AIR FILTER	1	*	*				110092505
2	5110 - 092 - 943 - XX	GASKET, MUFFLER	1	*	*				110092943
3	5110 - 102 - 327 - XX	FILTER - ASSY - AIR	1	1- -119615	*				110102327
3A	5110 - 102 - 421 - XX	FILTER - ASSY - AIR	1	119616-	*				110102421
4	5110 - 112 - 227 - XX	CASE - AIR FILTER	1	*	*				110112227
5	5110 - 122 - 223 - XX	CAP, AIR FILTER	1	*	*				110122223
6	5110 - 132 - 140 - XX	ELEMENT - AIR FILTER	1	1- -119615	*				110132140
6A	5110 - 132 - 109 - XX	ELEMENT - AIR FILTER	1	119616-	*				110132109
7	5110 - 132 - 110 - XX	ELEMENT - AIR FILTER	1	1- -119615	*				110132110
7A	5110 - 132 - 141 - XX	ELEMENT - AIR FILTER	1	119616-	*				110132141
8	5490 - 702 - 547 - 9Y	MUFFLER - COMP	1	*	*				4907025479Y
9	5110 - 122 - 251 - 9Y	CAP SPARK ARRESTER	1	*	*				1101222519Y
10	5180 - 772 - 052 - XX	ARRESTER - SPARK	2	*	*				180772052
11	5920 - 092 - 166 - XX	SCREW, 5X8	3	*	*				920092166
12	5920 - 022 - 274 - XX	BOLT	2	*	*				920022274
13	5920 - 222 - 220 - XX	WASHER	2	*	*				920222220
14	5317 - R08 - 00X - XX	NUT - HEX - SMALL	2	*	*				317R0800
15	5461 - F08 - 00X - XX	WASHER - SPRING	2	*	*				461F0800

FIG. 10 FUEL TANK FUEL VALVE

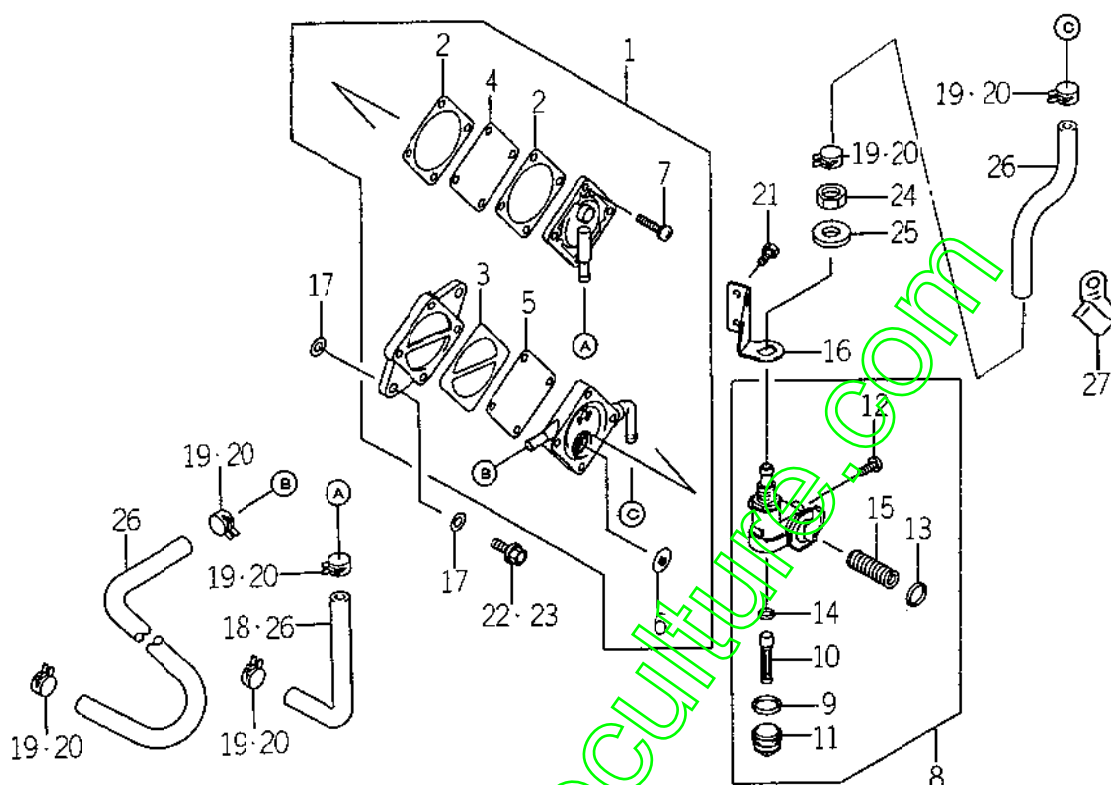

KS02-C100

KEY	PART CODE	DESCRIPTION	QTY	TYPE OF MODEL		I T C	C O L	G R P	REMARKS
				FC420V CB00	FC420V FB00				
1	5490 - 402 - 066 - XX	PUMP - FUEL	1	*	*				490402066
2	5110 - 092 - 763 - XX	GASKET, FUEL PUMP	2	*	*				110092763
3	5110 - 092 - 764 - XX	GASKET, FUEL PUMP	1	*	*				110092764
4	5430 - 282 - 068 - XX	DIAPHRAGM	1	*	*				430282068
5	5430 - 282 - 069 - XX	DIAPHRAGM	1	*	*				430282069
6	5491 - 162 - 055 - XX	VALVE - ASSY	2	*	*				491162055
7	5920 - 092 - 212 - XX	SCREW	4	*	*				920092212
8	5510 - 232 - 130 - XX	TAP - ASSY	1	*	*				510232130
9	5110 - 092 - 526 - XX	GASKET	1	*	*				110092526
10	5140 - 432 - 064 - XX	FILTER, FUEL TAP	1	*	*				140432064
11	5510 - 362 - 068 - XX	CUP, FUEL TAP	1	*	*				510362068
12	5920 - 092 - 004 - XX	SCREW	1	*	*				920092004
13	5920 - 551 - 299 - XX	RING - O	1	*	*				920551299
14	5920 - 552 - 083 - XX	RING - O	1	*	*				920552083
15	5921 - 442 - 043 - XX	SPRING	1	*	*				921442043
16	5491 - 052 - 096 - XX	BRACKET - TAP	1	*	*				491052096
17	5920 - 225 - 53X - XX	WASHER	4	*	*				92022553
18	5920 - 592 - 169 - XX	TUBE	1	*	*				920592169
19	5921 - 702 - 043 - XX	CLAMP	6	*	*				921702043
20	5921 - 702 - 088 - XX	CLAMP	6	*	*				921702088
21	5130 - B05 - 08X - XX	BOLT - FLANGED	2	*	*				130B0508
22	5130 - B05 - 16X - XX	BOLT - FLANGED	2	*	*				130B0616
23	5130 - G06 - 14X - XX	BOLT - FLANGED	2	*	*				130G0614
24	5315 - B12 - 00X - XX	NUT - HEX - FINE	1	*	*				315B1200
25	5410 - B12 - 00X - XX	W - PLAIN - S	1	*	*				410B1200

FIG. 11 STARTER

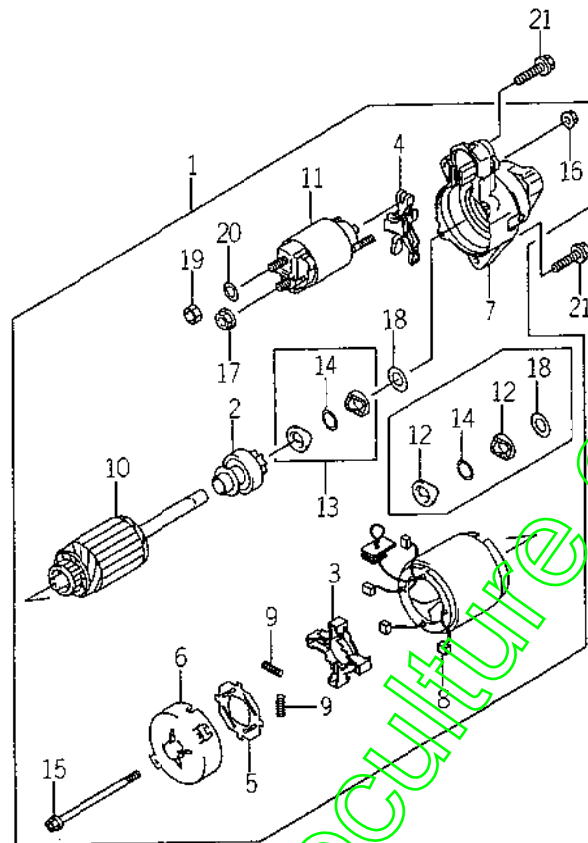

X502-0110

KEY	PART CODE	DESCRIPTION	QTY	TYPE OF MODEL		I T C	C O L	G R P	REMARKS
				FC420V CB00	FC420V FB00				
1	5211 - 632 - 073 - XX	STARTER - ELECTRIC	1	*	*				211632073
2	5130 - 812 - 085 - XX	CLUTCH - ASSY	1	*	*				130812085
3	5130 - 912 - 068 - XX	HOLDER, BRUSH	1	*	*				130912068
4	5131 - 682 - 131 - XX	LEVER, SHIFT	1	*	*				131682131
5	5160 - 732 - 098 - XX	INSULATOR	1	*	*				160732098
6	5161 - 462 - 077 - XX	COVER - ASSY	1	*	*				161462077
7	5161 - 462 - 106 - XX	COVER - ASSY	1	*	*				161462106
8	5210 - 392 - 059 - XX	BRUSH	4	*	*				210392059
9	5210 - 402 - 052 - XX	SPRING - BRUSH	4	*	*				210402052
10	5210 - 802 - 054 - XX	ARMATURE	1	*	*				210802054
11	5270 - 102 - 122 - XX	SWITCH	1	*	*				270102122
12	5320 - 852 - 066 - XX	STOPPER	1	*	*				320852066
13	5320 - 852 - 097 - XX	STOPPER	1	*	*				320852097
14	5920 - 332 - 081 - XX	RING - SNAP	1	*	*				920332081
15	5920 - 022 - 277 - XX	BOLT	2	*	*				920022277
16	5920 - 152 - 145 - XX	NUT	2	*	*				920152146
17	5920 - 152 - 147 - XX	NUT	1	*	*				920152147
18	5920 - 222 - 213 - XX	WASHER	1	*	*				920222218
19	5317 - B08 - 00X - XX	NUT - HEX - SMALL	1	*	*				317B0800
20	5461 - F08 - 00X - XX	WASHER - SPRING	1	*	*				461F0800
21	5130 - B08 - 35X - XX	BOLT - FLANGED	2	*	*				130B0835

FIG. 13 ACCESSORY

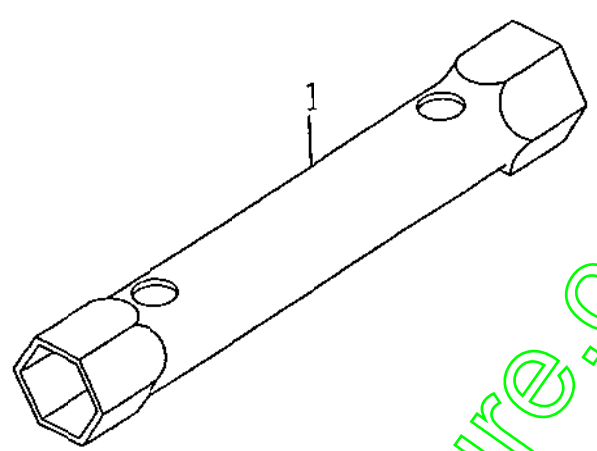

K502-C130

KEY	PART CODE	DESCRIPTION	QTY	TYPE OF MODEL		I T C	C O L	G R P	REMARKS
				FC420V CB00	FC420V FB00				
1	5921 - 102 - 093 - XX	TOOL - WRENCH 19X21	1	*	*				921102093

www.emc-motoculture.com

CHASSIS

www.emc-motoculture.com

FIG. 1 SHROUD AND FUEL TANK SYSTEM

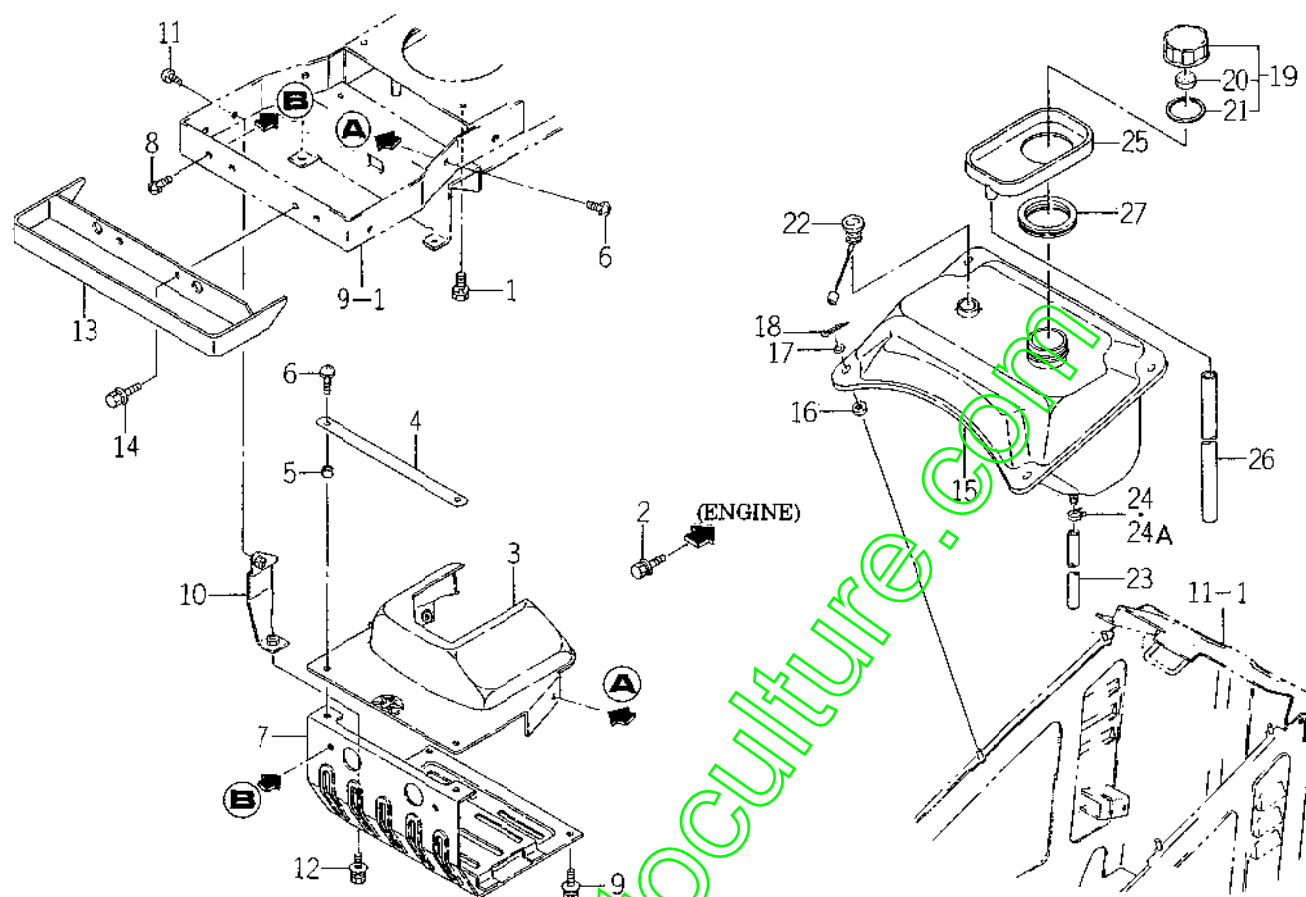

2502-101

KEY	PART CODE	DESCRIPTION	QTY	TYPE OF MODEL		I T C	C O L	G R P	REMARKS
				SL14H					
1	V211 - 260 - 802 - 50	BOLT/S	4	*					
2	V211 - 360 - 802 - 00	BOLT (SP) M8X20	2	*					
3	2502 - 101 - 210 - 30	SHROUD,UPPER COMP	1	*					
4	2502 - 101 - 003 - 00	PLATE /IR/ 22X290	1	*					
5	4334 - 155 - 003 - 00	COLLAR /6.5X10.5X8	2	*					
6	1581 - 740 - 116 - 00	SCREW /M6X20	4	*					
7	2502 - 101 - 220 - 10	SHROUD,LOWER COMP	1	*					
8	1581 - 740 - 116 - 00	SCREW /M6X20	2	*					
9	V210 - 360 - 602 - 00	BOLT /M6X20	2	*					
10	2502 - 101 - 230 - 00	STAY,SHROUD COMP	1	*					
11	1581 - 740 - 116 - 00	SCREW /M6X20	1	*					
12	V210 - 360 - 602 - 00	BOLT /M6X20	1	*					
13	2502 - 101 - 240 - 00	GUIDE,MUFFLER COMP	1	*					
14	V211 - 360 - 802 - 00	BOLT (SP) M8X20	2	*					
15	2502 - 105 - 001 - 10	TANK,FUEL	1	*					
16	2502 - 105 - 003 - 00	INSULATOR /09X20X04	4	*					
17	V411 - 260 - 008 - 00	WASHER,PL /M 8	4	*					
18	V500 - 163 - 002 - 00	PIN,SPLIT /3 X20	4	*					
19	1593 - 612 - 220 - 10	CAP,TANK	1	*					
20	2706 - 501 - 003 - 00	BREATHER,TANK CAP	1	*					
21	2706 - 501 - 004 - 00	GASKET	1	*					
22	1593 - 612 - 230 - 00	GAUGE,FUEL	1	*					
23	2502 - 105 - 002 - 00	HOSE /350	1	*					
24	3741 - 141 - 005 - 00	BAND,HOSE ASSY /12	2	1- -2935					
24A	J061 - 210 - 012 - 00	CLSMP,WIRE /10 - 12	2	2936-					

FIG. 2 BATTERY SYSTEM

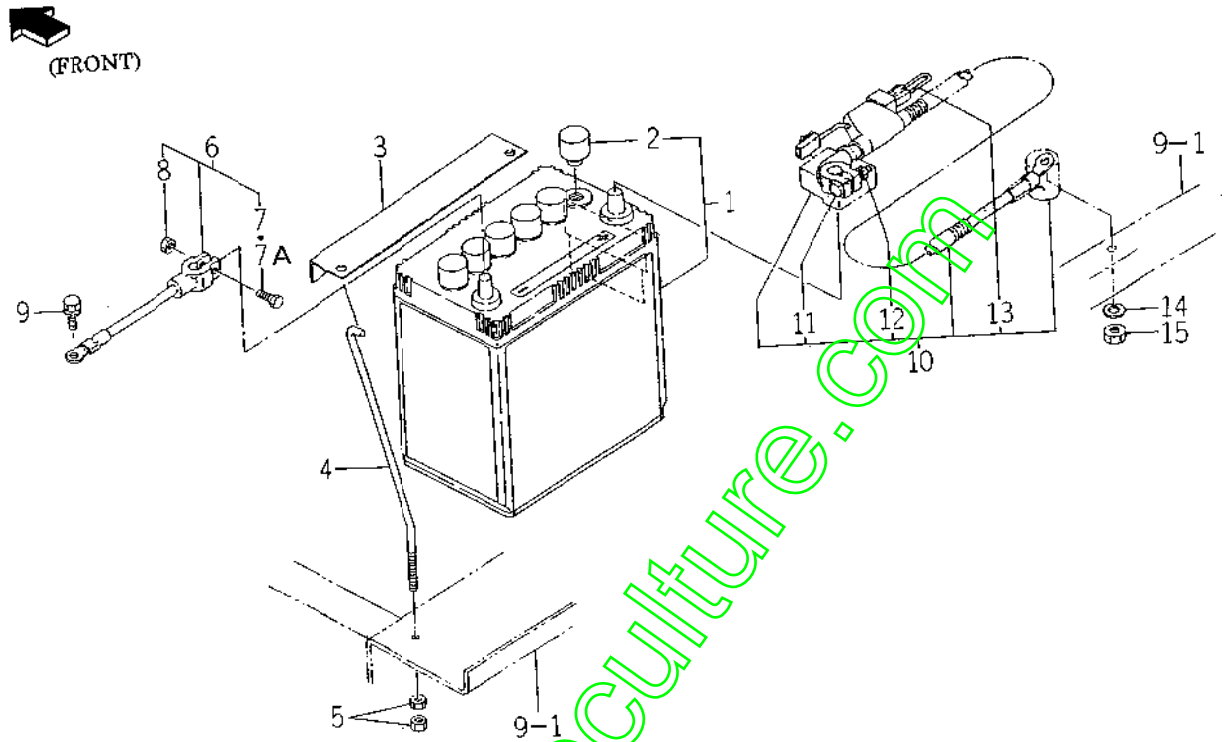

2502-112

KEY	PART CODE	DESCRIPTION	QTY	TYPE OF MODEL		I T C	C O L	G R P	REMARKS
				SL14H					
1	1593 - 112 - 200 - 00	BATTERY,	1	*					
2	1427 - 621 - 002 - 10	CAP,BATTERY	1	*					
3	1593 - 112 - 051 - 30	HOLDER,BATTERY	1	*					
4	2502 - 112 - 001 - 20	BOLT,BATTERY	2	*					
5	V301 - 260 - 006 - 00	NUT/M 6	4	*					
6	1593 - 112 - 003 - 20	CABLE,EARTH	1	*					
7	1600 - 112 - 231 - 00	BOLT/M06X32	1	*	1-433				
7A	1593 - 112 - 222 - 00	BOLT/M06X28	1	*	434-				
8	1600 - 112 - 232 - 00	NUT/M06	1	*					
9	V211 - 260 - 801 - 60	BOLT,SEMS (S) M8X16	1	*					
10	2502 - 112 - 210 - 10	CABLE,BATTERY ASSY	1	*					
11	1600 - 112 - 231 - 00	BOLT/M06X32	1	*					
12	1600 - 112 - 232 - 00	NUT/M06	1	*					
13	3652 - 261 - 202 - 00	LINK,FUSIBLE	1	*					
14	V401 - 160 - 008 - 00	WASHER,SP/M 8	1	*					
15	V304 - 260 - 008 - 00	NUT/M 8	1	*					

FIG. 4 BELT (DRIVING) AND HST SYSTEM

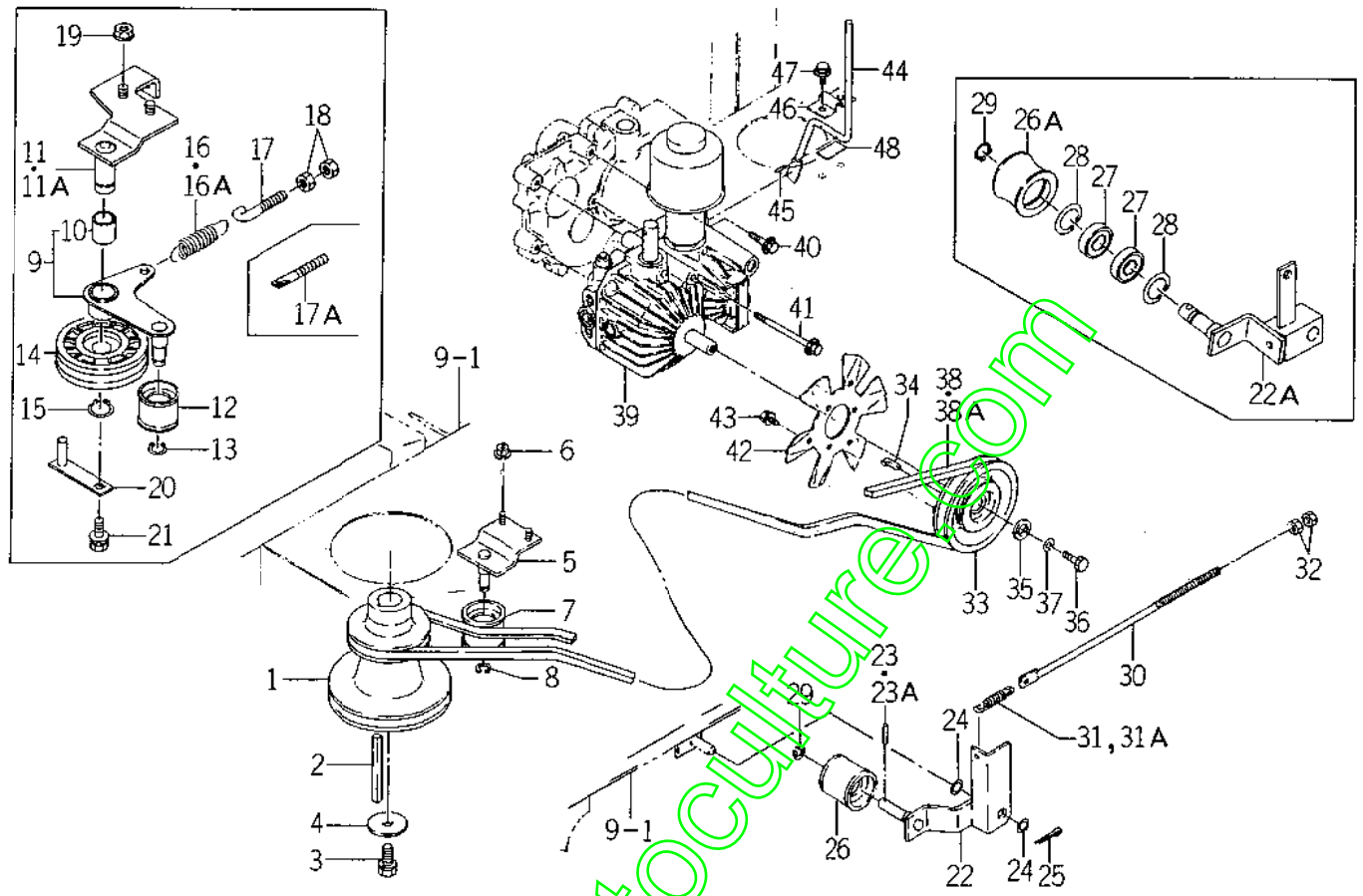

2502-201

KEY	PART CODE	DESCRIPTION	QTY	TYPE OF MODEL		I T C	C O L	G R P	REMARKS
				SL14H					
1	2502 - 201 - 003 - 20	PULLEY/V2B120B90	1	*					
2	2502 - 201 - 004 - 10	KEY/06X07X63	1	*					
3	V211 - 561 - 003 - 00	BOLT/M10X30	1	*					
4	1383 - 301 - 002 - 00	WASHER/11X44X5	1	*					
5	2502 - 201 - 210 - 40	ARM,TENSION/F COMP	1	1-790					
6	V363 - 260 - 008 - 00	NUT,LOCK/M8	2	1-790					
7	3614 - 125 - 001 - 00	PULLEY,TENSION	1	1-790					
8	V704 - 140 - 012 - 00	RING,SNAP/12 C	1	1-790					
9	2502 - 201 - 200 - 00	ARM/TENSION/F	1	791-					
10	8650 - 203 - 001 - 10	BUSH/20X23X20	1	791-					
11	2502 - 201 - 260 - 00	BRACKET/TENSION	1	1-790					
11A	2502 - 201 - 260 - 10	BRACKET/TENSION COMP	1	791-					
12	3614 - 125 - 001 - 00	PULLEY,TENSION	1	791-					
13	V704 - 140 - 012 - 00	RING,SNAP/12 C	1	791-					
14	4131 - 206 - 015 - 00	PULLEY/TENSION	1	791-					
15	V704 - 140 - 020 - 00	RING,SNAP/20	1	791-					
16	1325 - 401 - 009 - 00	SPRING,MAIN CLUTCH	1	1-647					
16A	3640 - 703 - 001 - 00	SPRING,MAIN CLUTCH	1	648-					
17	3737 - 341 - 007 - 00	ROD	1	1-790					
17A	3737 - 233 - 006 - 00	ROD	1	791-					
18	V304 - 260 - 008 - 00	NUT/M 8	2	791-					
19	V363 - 260 - 008 - 00	NUT,LOCK/M8	2	791-					
20	2502 - 201 - 270 - 00	PLATE/1/19X78 COMP	1	*					
21	V211 - 360 - 801 - 60	BOLT,SEMS (3P)	1	*					
22	2502 - 201 - 220 - 40	ARM,TENSION/HST COMP	1	1-647					

FIG. 4 BELT (DRIVING) AND HST SYSTEM

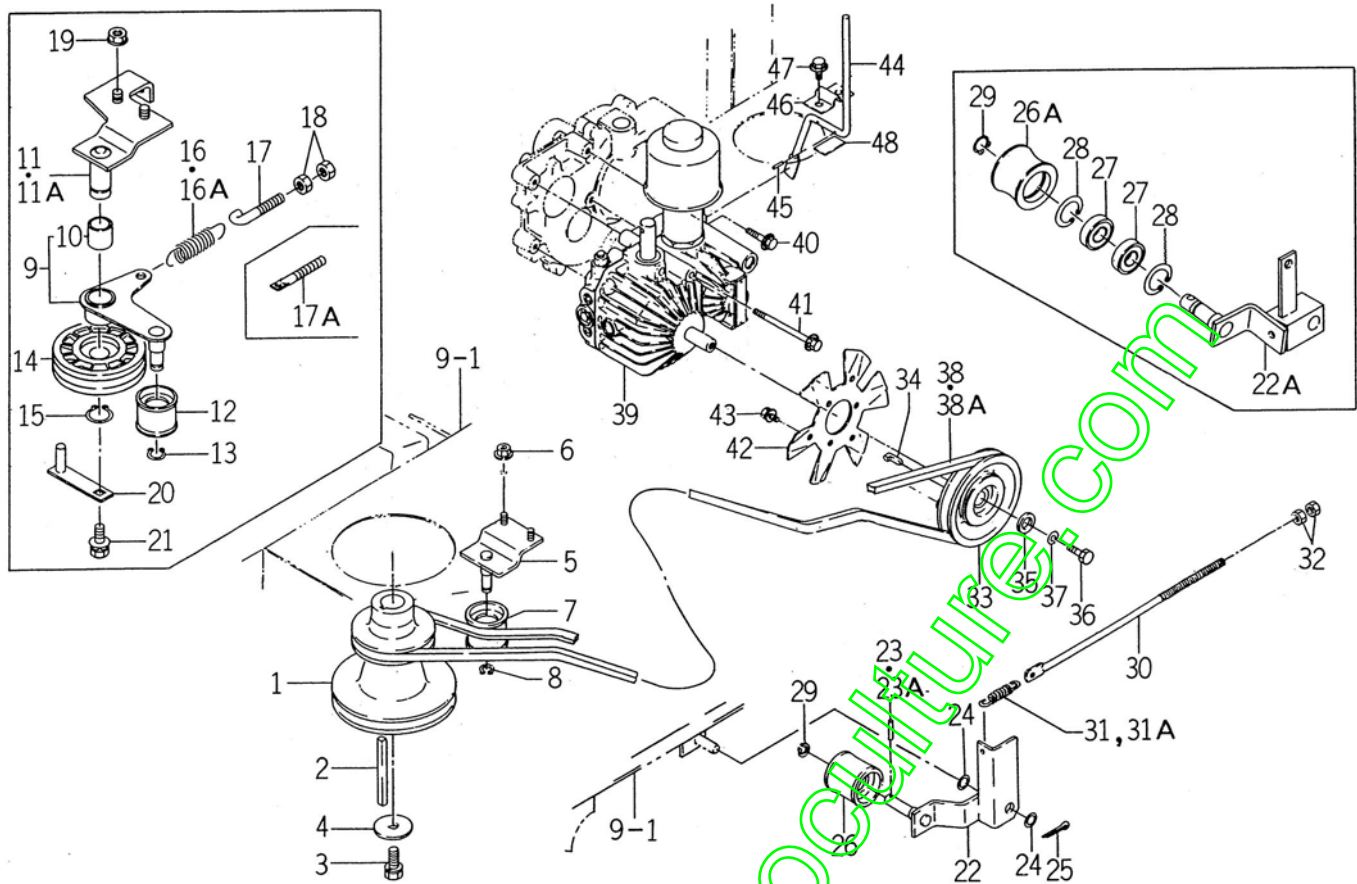

2502-201

KEY	PART CODE	DESCRIPTION	QTY	TYPE OF MODEL			REMARKS
				SL14H	I T C	C O L	
22A	2502 - 201 - 220 - 50	ARM,TENSION/HST COMP	1	648-			
23	V580 - 140 - 604 - 00	PIN,APRING/6 X40 W	1	1- -647 648-			
23A	V580 - 140 - 604 - 50	PIN,SPRING/6 X40 W	1	648-			
24	V411 - 260 - 014 - 00	WASHER,PL/M14	2	*			
25	V500 - 163 - 002 - 50	PIN,SPLIT/3 X25	1	*			
26	2502 - 532 - 002 - 10	PULLEY,TENSION/045	1	1- -647 648-			
26A	2502 - 201 - 014 - 00	PULLEY,TENSION/045	1	648-			
27	2502 - 201 - 015 - 00	BEARING RB	2	648-			
28	V705 - 140 - 035 - 00	RING,SNAP/35 C	2	648-			
29	V704 - 140 - 015 - 00	RING,SNAP/15 C	1	*			
30	2502 - 201 - 007 - 20	ROD/M08X295	1	*			
31	1325 - 401 - 009 - 00	SPRING,MAIN CLUTCH	1	1- -647 648-			
31A	3640 - 703 - 001 - 00	SPRING,MAIN CLUTCH	1	648-			
32	V304 - 260 - 008 - 00	NUT/M 8	2	*			
33	2502 - 201 - 001 - 10	PULLEY/VB105	1	*			
34	2502 - 201 - 005 - 10	KEY/05X05X24	1	*			
35	3754 - 371 - 011 - 00	WASHER	1	*			
36	V200 - 360 - 601 - 60	BOLT	1	*			
37	V401 - 160 - 006 - 00	S.W	1	*			
38	2502 - 201 - 006 - 20	BELT/VB079	1	1- -790 791-			
38A	2502 - 201 - 006 - 30	BELT/VB078.5	1	791-			
39	2502 - 205 - 200 - 00	HST	1	*			FIG. 4A
40	V211 - 360 - 804 - 00	BOLT,SP/M8X40	2	*			
41	V211 - 360 - 811 - 00	BOLT,SP/M8X110	2	*			
42	2502 - 205 - 001 - 10	FAN,HST	1	*			

FIG. 4 A

TRANSMISSION

H. S. T.

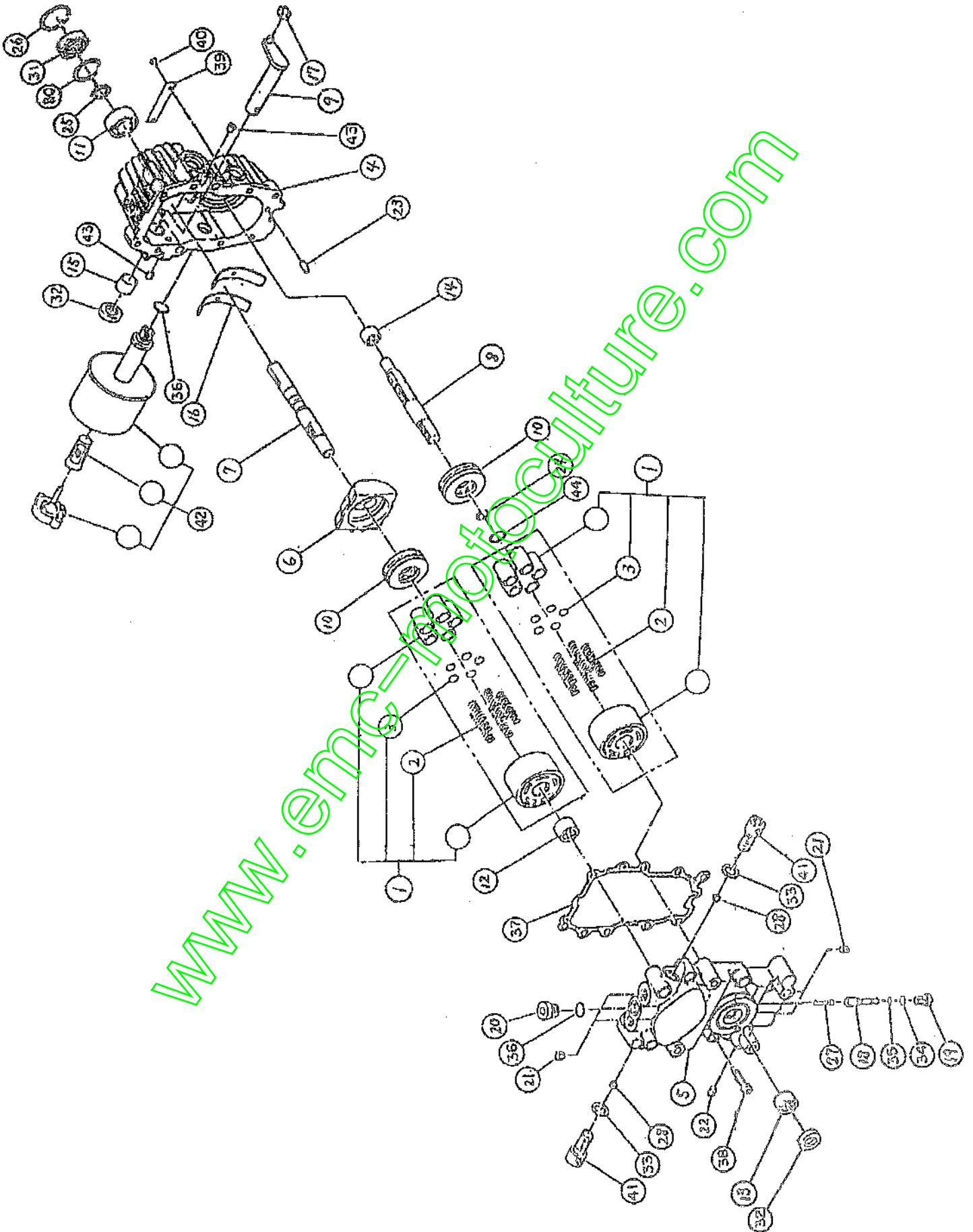
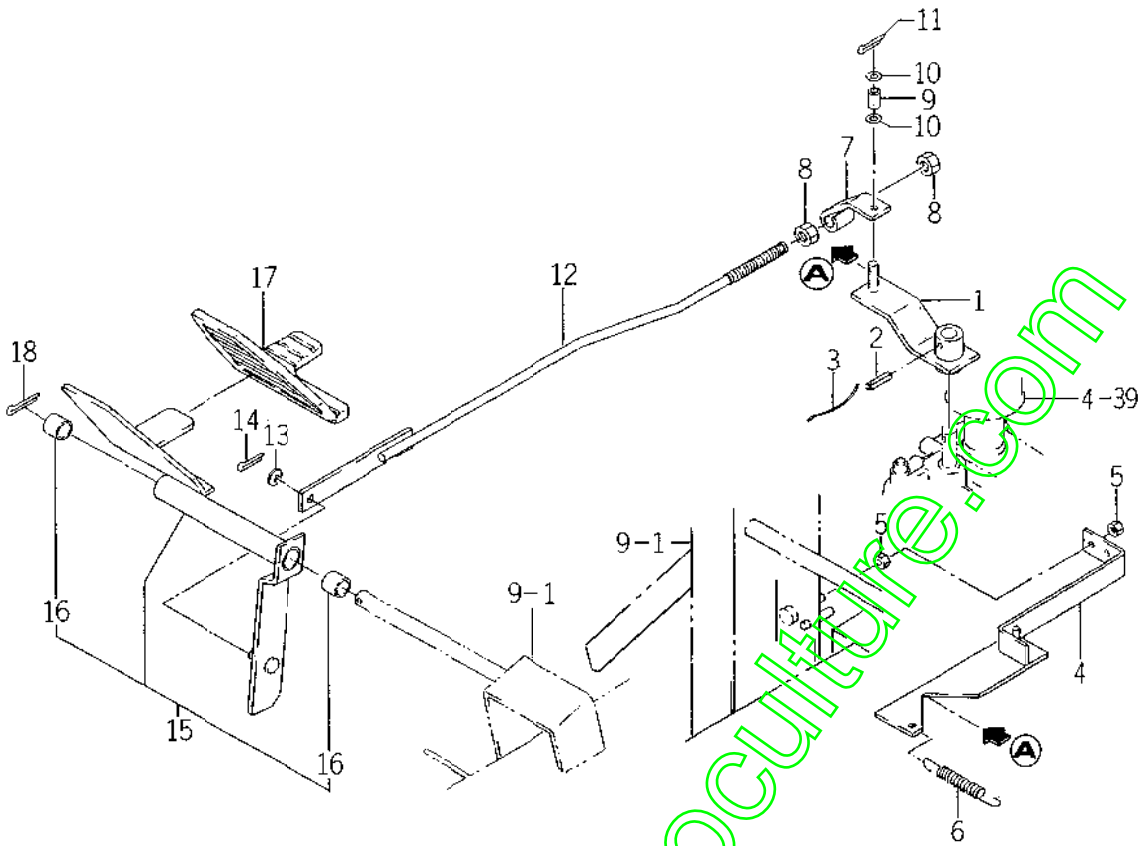

FIG. 4A

TRANSMISSION H.S.T.

REPÈRE	REFERENCE	DESIGNATION	QTE
0-1	2502 205 2000 0	TRANSMISSION COMPLETE	1
1	2502 205 2600 0	BLOC CYLINDRE	2
2	2502 205 2630 0	RESSORT	5
3	2502 205 2640 0	SUPPORT	5
4	2502 205 2010 0	CARTER	1
5	2502 205 2020 0	BLOC LUMIERE	1
6	2502 205 2030 0	PLAQUE	1
7	2502 205 2040 0	AXE	1
8	2502 205 2050 0	AXE	1
9	2502 205 2060 0	AXE	1
10	2502 205 2070 0	ROULEMENT	2
11	2502 205 2080 0	ROULEMENT (5202)	1
12	2502 205 2090 0	ROULEMENT	1
13	2502 205 2110 0	ROULEMENT	1
14	2502 205 2120 0	ROULEMENT	1
15	2502 205 2130 0	COUSSINET	1
16	2502 205 2140 0	ROULEMENT	2
17	2502 205 2150 0	PLAQUE	1
18	2502 205 2160 0	SOUPAPE	1
19	2502 205 2170 0	BOUCHON	1
20	2502 205 2180 0	BOUCHON	1
21	2502 205 2190 0	BOUCHON	4
22	2502 205 2210 0	BOUCHON	1
23	1608 205 2370 0	GOUPILLE	2
24	2502 205 2220 0	CIRCLIPS	1
25	V704 140 0150 0	CIRCLIPS	1
26	V705 140 0350 0	CIRCLIPS	1
27	2502 205 2230 0	RESSORT	1
28	2502 205 2240 0	BILLE ACIER	2
30	2502 205 2250 0	COLLIER	1
31	2502 205 2510 0	BAGUE D'ETANCHEITE	1
32	2502 205 2520 0	BAGUE D'ETANCHEITE	2
33	2502 205 2530 0	BAGUE	2
34	V720 111 9008 0	JOINT TORIQUE	1
35	1608 205 2320 0	JOINT TORIQUE	1
36	V720 112 4014 0	JOINT TORIQUE	2
37	2502 205 2540 0	JOINT	1
38	2502 205 2260 0	VIS	3
41	2502 205 2270 0	BOULON	2
42	2502 205 2280 0	RESERVOIR	1
43	2502 205 2290 0	TROP-PLEIN	2
44	2502 205 2410 0	ANNEAU	1

FIG. 5 PEDAL (HST) SYSTEM



2502-221

KEY	PART CODE	DESCRIPTION	QTY	TYPE OF MODEL		I T C	C O L	G R P	REMARKS
				SL14H					
1	2502 - 221 - 210 - 20	HUB,TRINION COMP	1	*					
2	V580 - 140 - 602 - 50	PIN,SPRING/6 X25 W	1	*					
3	V590 - 131 - 210 - 00	WIRE/1.2X100	1	*					
4	2502 - 221 - 220 - 20	LINK,NEWTRIL COMP	1	*					
5	V304 - 260 - 008 - 00	NUT/M 8	2	*					
6	1415 - 120 - 006 - 00	SPRING,TENSION/86	1	*					
7	2502 - 221 - 001 - 10	PLATE,ADJUST	1	*					
8	V304 - 260 - 010 - 00	NUT	2	*					
9	2502 - 221 - 003 - 00	HUB/Ø8X12X15	1	*					
10	V411 - 260 - 008 - 00	WASHER,PL/M 8	2	*					
11	V500 - 163 - 001 - 50	PIN,SPLIT/3 X15	1	*					
12	2502 - 221 - 250 - 10	BODY/M10X505 COMP	1	*					
13	V411 - 260 - 008 - 00	WASHER,PL/M 8	1	*					
14	V500 - 163 - 001 - 50	PIN,SPLIT/3 X15	1	*					
15	2502 - 221 - 200 - 00	PEDAL,HST ASSY	1	*					
16	2502 - 221 - 236 - 00	BUSH/18X20X15	2	*					
17	2502 - 221 - 002 - 20	PAD,PEDAL	1	*					
18	V500 - 163 - 002 - 50	PIN,SPLIT/3 X25	1	*					

FIG. 6 CASE (TRANSMISSION) SYSTEM

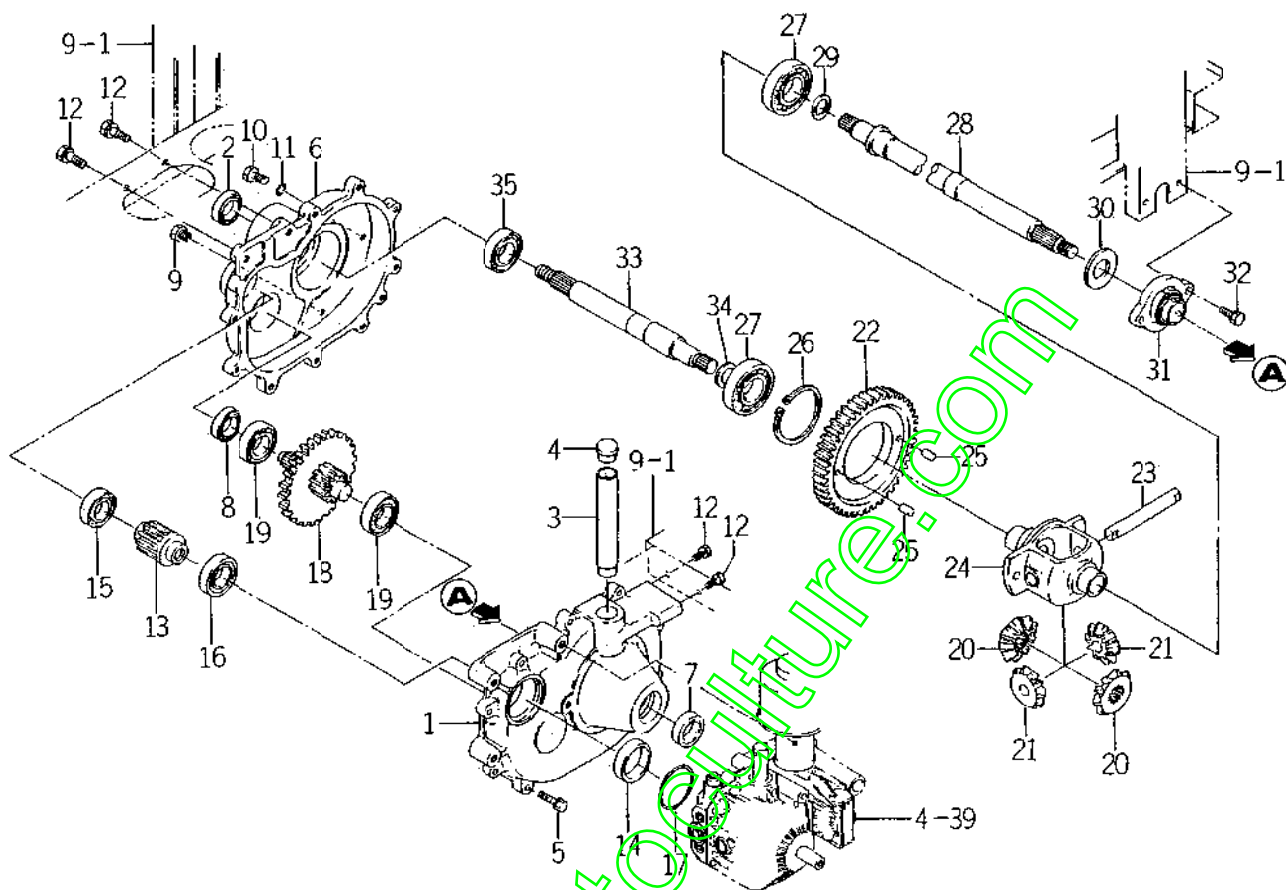

2501-301

KEY	PART CODE	DESCRIPTION	QTY	TYPE OF MODEL		I T C	C O L	G R P	REMARKS
				SL14H					
1	2502 - 301 - 001 - 30	CASE,TRANSMISSION / LH	1	*					
2	V744 - 125 - 400 - 80	SEAL,OIL / TC25408	1	*					
3	2502 - 301 - 003 - 20	TUBE / 140	1	*					
4	2111 - 101 - 011 - 00	PLUG,OIL	1	*					
5	V211 - 260 - 803 - 00	BOLT,SEMS	10	*					
6	2502 - 301 - 002 - 30	CASE,TRANSMISSION / RH	1	*					
7	V744 - 125 - 400 - 80	SEAL,OIL / TC25408	1	*					
8	V744 - 120 - 350 - 70	SEAL,OIL / TC20357	1	*					
9	7955 - 201 - 026 - 00	PLUG,DRAIN (1/4)	1	*					
10	V201 - 260 - 801 - 80	BOLT / M 8X16	1	*					
11	V720 - 101 - 900 - 80	O - RING / P 8	1	*					
12	V211 - 560 - 802 - 00	BOLT / M8X20	6	*					
13	2502 - 302 - 001 - 30	GEAR / 12T	1	*					
14	2502 - 302 - 002 - 20	COLLAR / 42X47X13	1	*					
15	V600 - 110 - 600 - 40	BEARING,RB / 6004	1	*					
16	V600 - 110 - 600 - 50	BEARING,RB / 6005	1	*					
17	V721 - 103 - 104 - 50	O - RING / G45	1	*					
18	2502 - 303 - 210 - 10	GEAR,SHAFT / 9 - 43TCOMP	1	*					
19	V600 - 110 - 620 - 40	BEARING,RB / 6204	2	*					
20	2502 - 304 - 002 - 20	GEAR / 15T	2	*					
21	2502 - 304 - 003 - 20	GEAR / 11T	2	*					
22	2502 - 304 - 004 - 30	GEAR / 51T	1	*					
23	2502 - 304 - 005 - 20	PIN,DIFF PINION	1	*					
24	2502 - 304 - 001 - 20	CASE,DIFF	1	*					
25	1593 - 304 - 003 - 00	PIN (10X18)	2	*					

FIG. 7 BRAKE SYSTEM

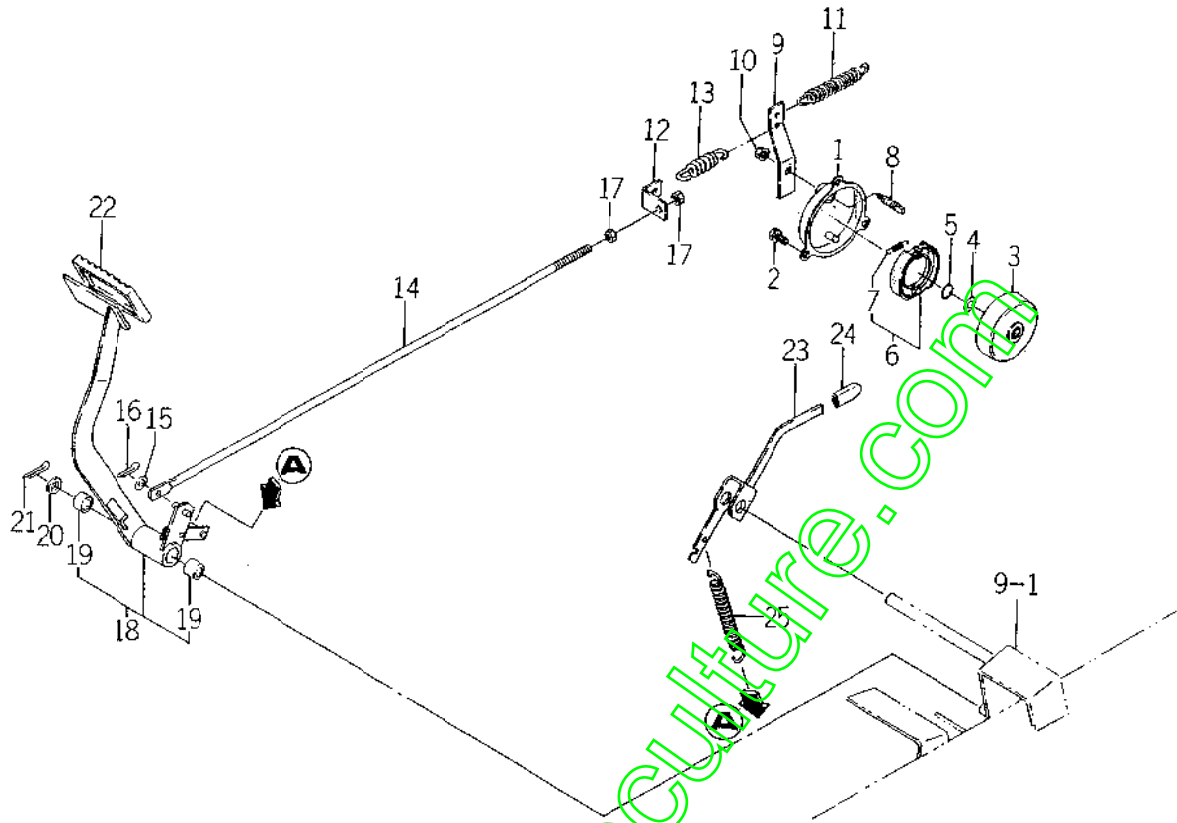

2502-316

KEY	PART CODE	DESCRIPTION	QTY	TYPE OF MODEL		I T C	C O L	G R P	REMARKS
				SL14H					
1	2502 - 310 - 240 - 10	COVER,BRAKE COMP	1	*					
2	V211 - 260 - 801 - 60	BOLT,SEMS (S) M8X16	3	*					
3	1593 - 310 - 520 - 20	DRUM,BRAKE	1	*					
4	V411 - 260 - 012 - 00	WASHER / M:2	1	*					
5	V704 - 140 - 012 - 00	RINGSNAP / 12 C	1	*					
6	1593 - 310 - 540 - 00	SHOE,BRAKE ASSY	1	*					
7	1323 - 220 - 012 - 00	SPRING,BRAKE SHOE	1	*					
8	1593 - 310 - 054 - 20	PIN / 15X47	1	*					
9	2502 - 310 - 001 - 20	ARM,BRAKE	1	*					
10	V363 - 260 - 008 - 00	NUT,LOCK / M8	1	*					
11	2130 - 601 - 006 - 20	SPRING,TENSION	1	*					
12	2502 - 310 - 002 - 20	ADJUSTER,ROD	1	*					
13	2111 - 441 - 027 - 10	SPRING,HYD CLUTCH	1	*					
14	2502 - 310 - 003 - 20	ROD / M08X555	1	*					
15	V411 - 260 - 008 - 00	WASHER,PL / M 8	1	*					
16	V500 - 163 - 001 - 50	PIN,SPLIT / 3 X15	1	*					
17	V304 - 260 - 008 - 00	NUT / M 8	2	*					
18	2502 - 310 - 200 - 10	HUB,BRAKE ASSY	1	*					
19	2502 - 221 - 236 - 00	BUSH / 18X20X15	2	*					
20	V411 - 260 - 018 - 00	WASHER / M18	1	*					
21	V500 - 163 - 003 - 00	PIN,SPLIT / 3 X30	1	*					
22	1518 - 122 - 002 - 00	PEDL B	1	*					
23	2502 - 311 - 210 - 30	LEVER,PARKING COMP	1	*					
24	3600 - 201 - 013 - 00	GRIP,BRAKE	1	*					
25	1415 - 120 - 006 - 00	SPRING,TENSION / 86	1	*					

FIG. 10 AXLE (FRONT) SYSTEM

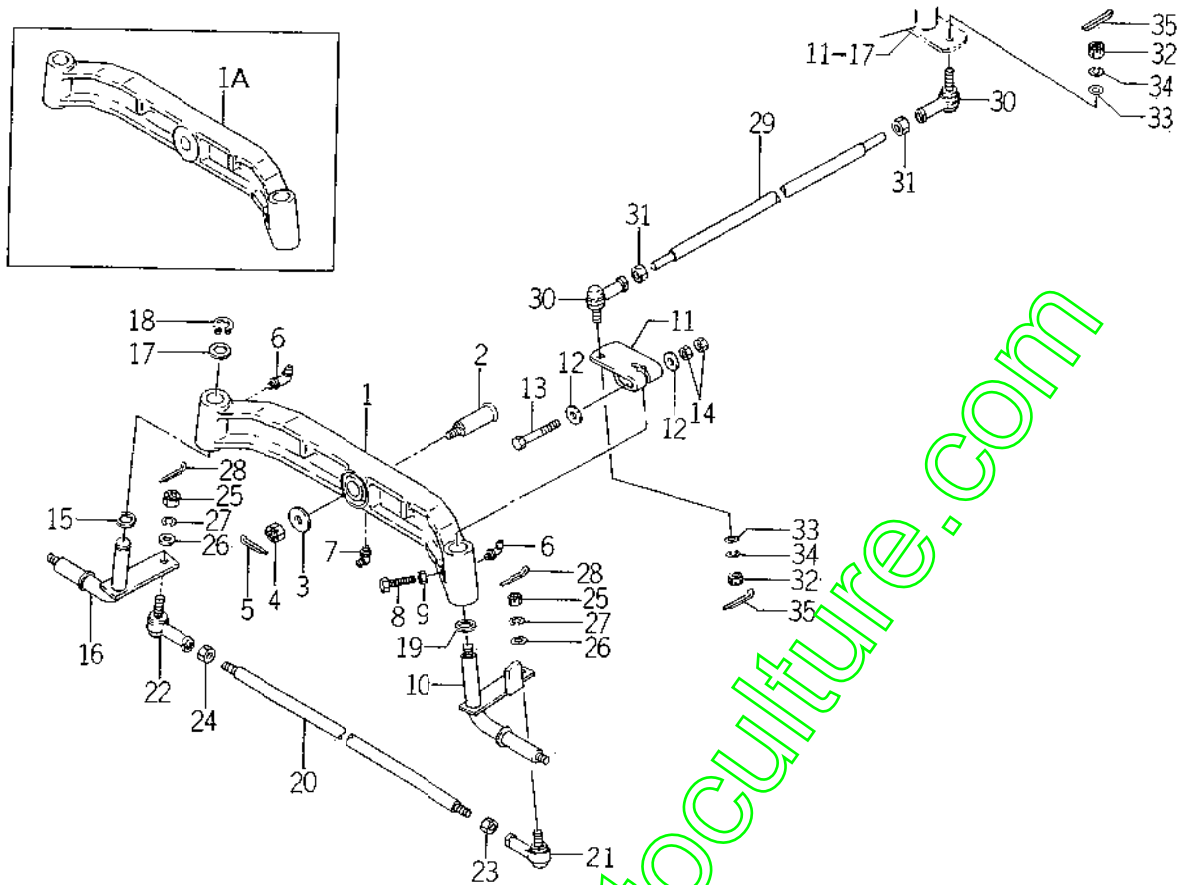

2502-4C2

KEY	PART CODE	DESCRIPTION	QTY	TYPE OF MODEL		I T C	C O L	G R P	REMARKS
				SL14H					
1	2502 - 402 - 005 - 30	AXLE,FRONT	1		1- -1990				
1A	2502 - 402 - 005 - 40	AXLE,FRONT	1		1991-				
2	2502 - 402 - 001 - 20	PIN/22X77	1	*					
3	3621 - 702 - 003 - 00	WASHER,PULLEY	1	*					
4	V328 - 262 - 112 - 00	NUT/M12X1.25	1	*					
5	V500 - 163 - 002 - 50	PIN,SPLIT/3 X 25	1	*					
6	V760 - 150 - 000 - 00	NIPPLE,GREASE	2	*					
7	V762 - 150 - 000 - 00	NIPPLE,GREASE/YB-M6F	1	*					
8	W201 - 361 - 006 - 00	BOLT/M10X60	1	*					
9	V304 - 260 - 010 - 00	NUT	1	*					
10	2502 - 403 - 210 - 40	ARM, KNUCKLE/LH COMP	1	*					
11	2502 - 403 - 004 - 10	ARM,PIT MAN	1	*					
12	3659 - 170 - 003 - 00	WASHER/11X30X3	2	*					
13	2502 - 403 - 006 - 00	BOLT	1	*					
14	V304 - 460 - 010 - 00	NUT/M10	2	*					
15	1365 - 224 - 002 - 00	WASHER	1	*					
16	2502 - 403 - 220 - 30	ARM, KNUCKLE/RH COMP	1	*					
17	2502 - 403 - 007 - 00	WASHER/20X28X2	1	*					
18	V704 - 140 - 020 - 00	RING,SNAP/20	1	*					
19	1365 - 224 - 002 - 00	WASHER	1	*					
20	2502 - 403 - 001 - 20	ROD,TIE	1	*					
21	2502 - 403 - 002 - 20	JOINT,BALL/LH	1	*					
22	1593 - 403 - 001 - 10	JOINT,BALL/RH	1	*					
23	2502 - 403 - 005 - 00	NUT/LH M10X1.25	1	*					
24	V334 - 260 - 010 - 00	NUT/M10	1	*					

FIG. 10 AXLE (FRONT) SYSTEM

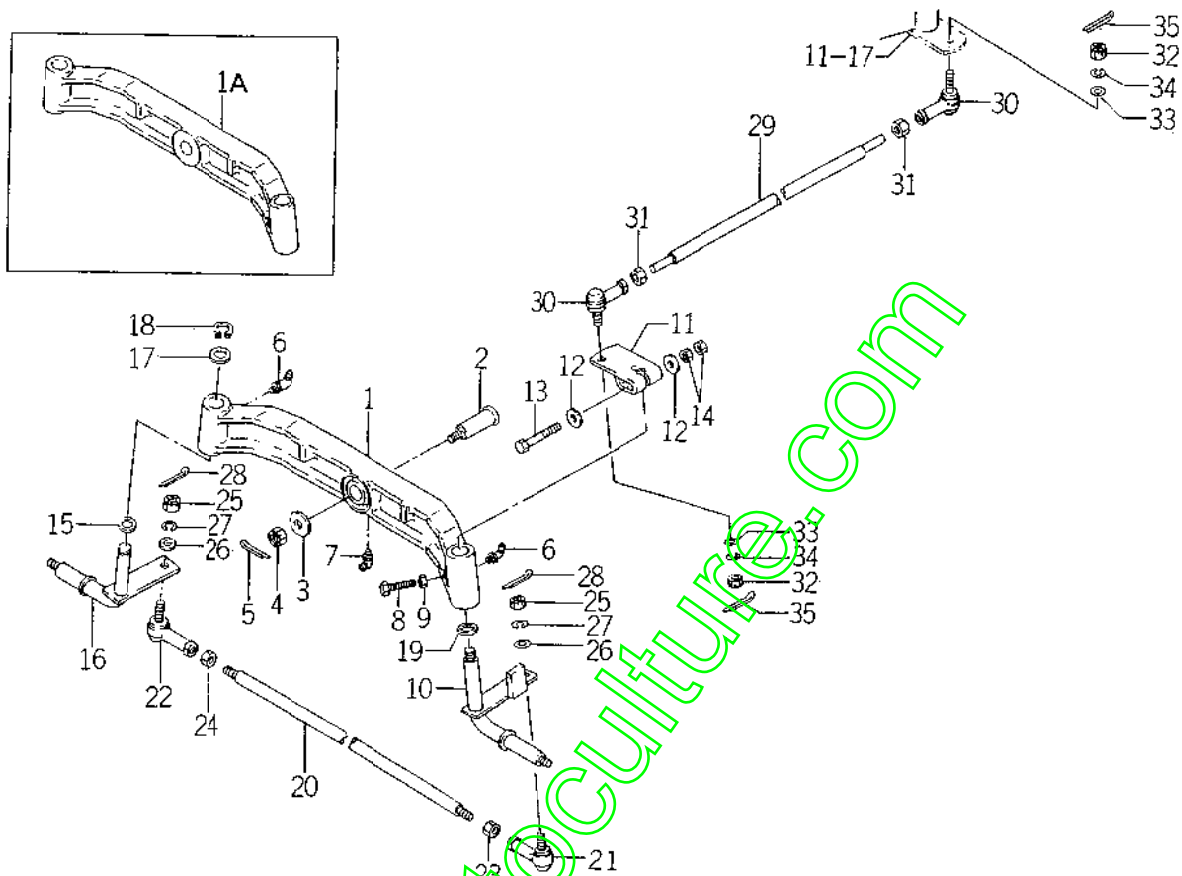

2502-403

KEY	PART CODE	DESCRIPTION	QTY	TYPE OF MODEL		I T C	C O L	G R P	REMARKS
				SLI4H					
25	V328 - 262 - 110 - 00	NUT/M10X1.25	2	*					
26	V411 - 260 - 010 - 00	WASHER/M10	2	*					
27	V401 - 160 - 010 - 00	WASHER,SP/M10	2	*					
28	V500 - 162 - 502 - 00	PIN,SPLIT/2.5X20	2	*					
29	2502 - 403 - 003 - 20	ROD,DRUG	1	*					
30	1593 - 403 - 005 - 00	JOINT,BALL	2	*					
31	V335 - 230 - 012 - 00	NUT/M12X1.25	2	*					
32	V328 - 252 - 112 - 00	NUT/M12X1.25	2	*					
33	V411 - 260 - 012 - 00	WASHER /M12	2	*					
34	V401 - 160 - 012 - 00	WASHER,SP/M12	1	*					
35	V500 - 163 - 002 - 50	PIN,SPLIT/3 X25	2	*					

FIG. 11 STEERING SYSTEM

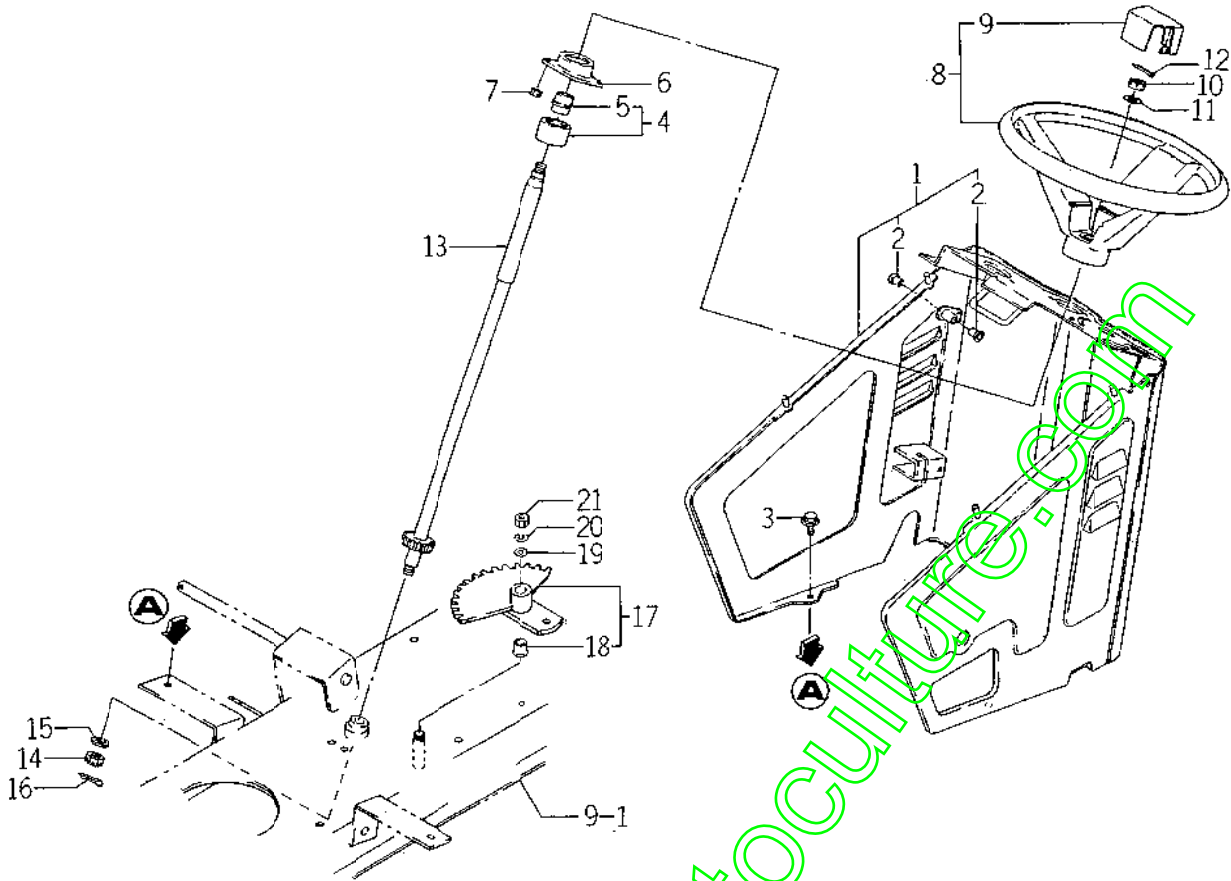

2302-406

KEY	PART CODE	DESCRIPTION	QTY	TYPE OF MODEL		I T C	C O L	G R P	REMARKS
				SL14H					
1	2502 - 406 - 200 - 20	COVER,LOWER ASSY	1	*					
2	1564 - 512 - 001 - 00	BUSH/10X12X10	2	*					
3	V211 - 360 - 801 - 50	BOLT,SEMS (SP)	4	*					
4	1593 - 406 - 250 - 00	COLUMN,STEERING ASSY	1	*					
5	1593 - 406 - 005 - 10	BUSH,COLUMN	1	*					
6	2502 - 406 - 001 - 10	HUB,STEERING COLUMN	2	*					
7	V363 - 260 - 008 - 00	NUT,LOCK/MB	2	*					
8	1593 - 406 - 240 - 10	WHEEL,STEERING ASSY	1	*					
9	1593 - 406 - 006 - 00	PAD,STEERING WHEEL	1	*					
10	V328 - 262 - 110 - 00	NUT/M10X1.25	1	*					
11	V411 - 260 - 010 - 00	WASHER/M10	1	*					
12	V500 - 162 - 502 - 00	PIN,SPLIT/2.5X20	1	*					
13	2502 - 407 - 210 - 30	SHAFT,STEERING COMP	1	*					
14	V328 - 262 - 110 - 00	NUT/M10X1.25	1	*					
15	3659 - 170 - 003 - 00	WASHER/11X30X3	1	*					
16	V500 - 162 - 502 - 00	PIN,SPLIT/2.5X20	1	*					
17	2502 - 407 - 200 - 20	GEAR/25T ASSY	1	*					
18	2502 - 407 - 001 - 10	BUSH/15X17X11	2	*					
19	3659 - 170 - 003 - 00	WASHER/11X30X3	1	*					
20	V401 - 160 - 010 - 00	WASHER,SP/M10	1	*					
21	V304 - 260 - 010 - 00	NUT	1	*					

FIG. 12 TIRE (FRONT) SYSTEM

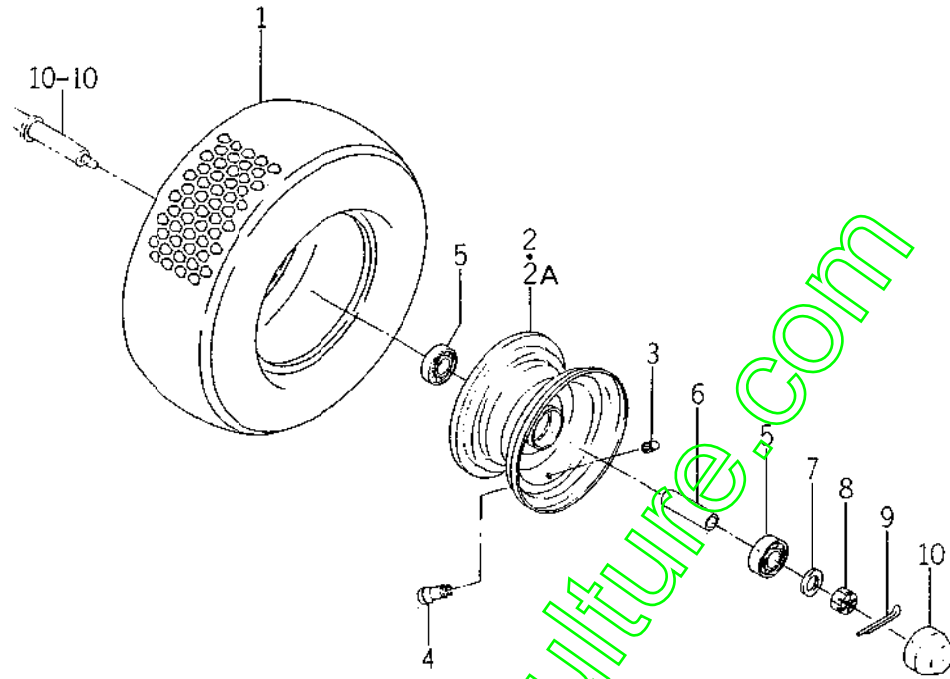

2502-111

KEY	PART CODE	DESCRIPTION	QTY	TYPE OF MODEL		I T C	C O L	G R P	REMARKS
				SL14H					
1	2502 - 411 - 201 - 00	TIRE,TURF/14-5	2	*					
2	2502 - 411 - 210 - 00	WHEEL/3.5X6 COMP	2	1- -1889					
2A	2502 - 411 - 210 - 10	WHEEL/3.5X6 COMP	2	1990-					
3	V999 - 200 - 003 - 00	CAP,TIRE VALVE	2	*					
4	1386 - 241 - 002 - 00	BULB	2	*					
5	V600 - 150 - 600 - 40	BEARING,RB/E004SS	4	*					
6	2502 - 411 - 001 - 00	COLLAR/21X25X46	2	*					
7	3859 - 170 - 003 - 00	WASHER/11X30X3	2	*					
8	V328 - 262 - 110 - 00	NUT/M10X1.25	2	*					
9	V500 - 162 - 502 - 50	PIN,SPLIT/2.5X25	2	*					
10	2502 - 317 - 002 - 00	CAP,WHEEL	2	*					

FIG. 13 P.T.O. SYSTEM

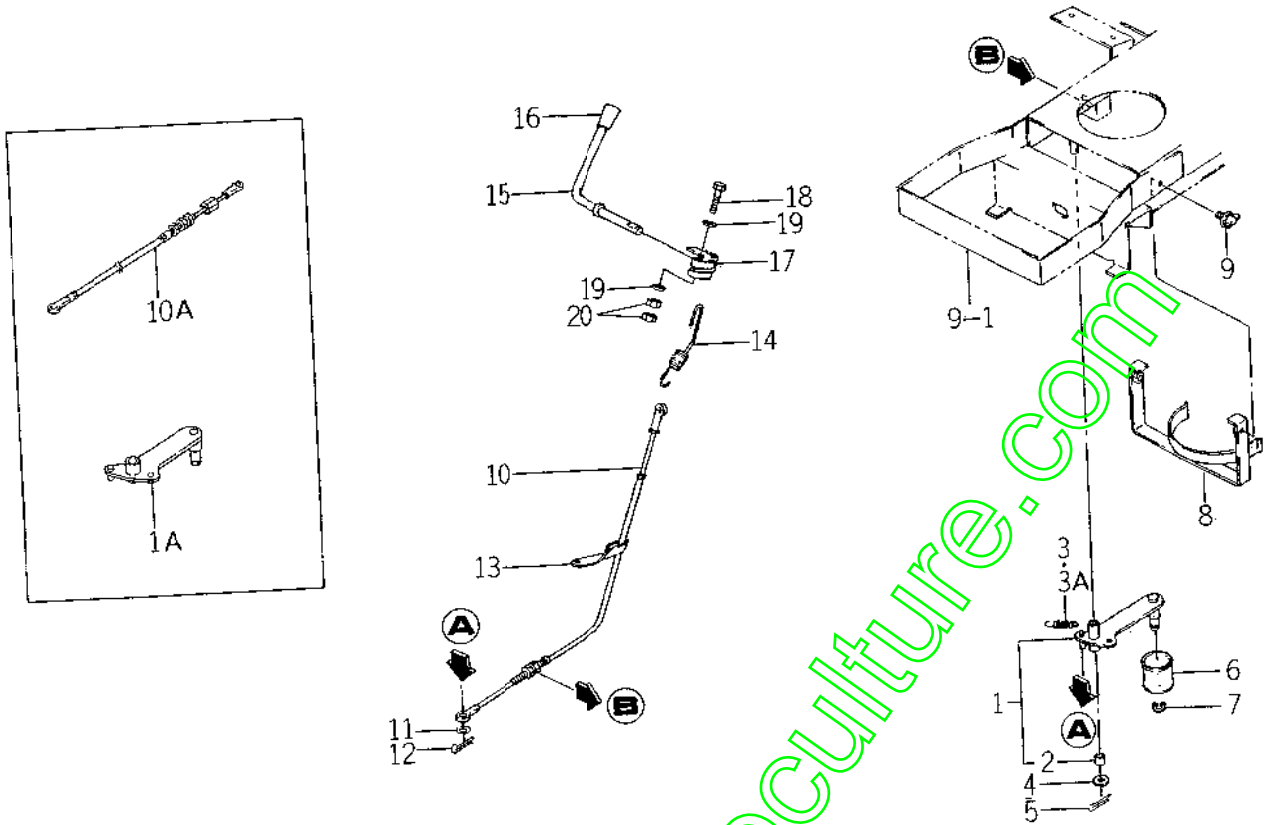

2502-532

KEY	PART CODE	DESCRIPTION	QTY	TYPE OF MODEL		I T C	C O L	G R P	REMARKS
				SL14H					
1	2502 - 532 - 230 - 20	ARM,PTO TENSION ASSY	1	1-					
1A	2502 - 532 - 230 - 30	ARM,PTO TENSION ASSY	1	-2395 2396-					
2	2502 - 532 - 001 - 10	BUSH / 15X17X15	2	*					
3	1415 - 125 - 021 - 00	SPRING,TENSION / 46	1	1-					
3A	3656 - 565 - 006 - 00	SPRING,HE066	1	-1350 1351-					
4	V411 - 260 - 014 - 00	WASHER,PL / M14	1	*					
5	V500 - 163 - 002 - 50	PIN,SPLIT / 3 X25	1	*					
6	2502 - 532 - 002 - 10	PULLEY, TENSION / 045	1	*					
7	V704 - 140 - 015 - 00	RING,SNAP / 15 C	1	*					
8	2502 - 532 - 220 - 40	STOPPER,BELT COMP	1	*					
9	V273 - 360 - 802 - 50	BOLT,WING SP / M8X25	2	*					
10	2502 - 532 - 200 - 20	CABLE,PTO ASSY	1	1-					
10A	2502 - 532 - 200 - 30	CABLE,PTO ASSY	1	-2395 2396-					
11	V411 - 260 - 008 - 00	WASHER,FL / M 8	1	*					
12	V500 - 163 - 001 - 50	PIN,SPLIT / 3 X15	1	*					
13	1425 - 621 - 004 - 00	CLAMP,HARNES	1	*					
14	1593 - 332 - 052 - 10	SPRING / HE014	1	*					
15	2502 - 533 - 230 - 00	LEVER,PTO COMP	1	*					
16	4106 - 105 - 303 - 00	KNOB	1	*					
17	2502 - 533 - 002 - 10	P.ATE,PTO LEVER	1	*					
18	V201 - 260 - 804 - 50	BOLT / M 8X45	1	*					
19	V411 - 260 - 008 - 00	WASHER,FL / M 8	2	*					
20	V304 - 260 - 008 - 00	NUT / M 8	2	*					

FIG. 14 LINK SYSTEM

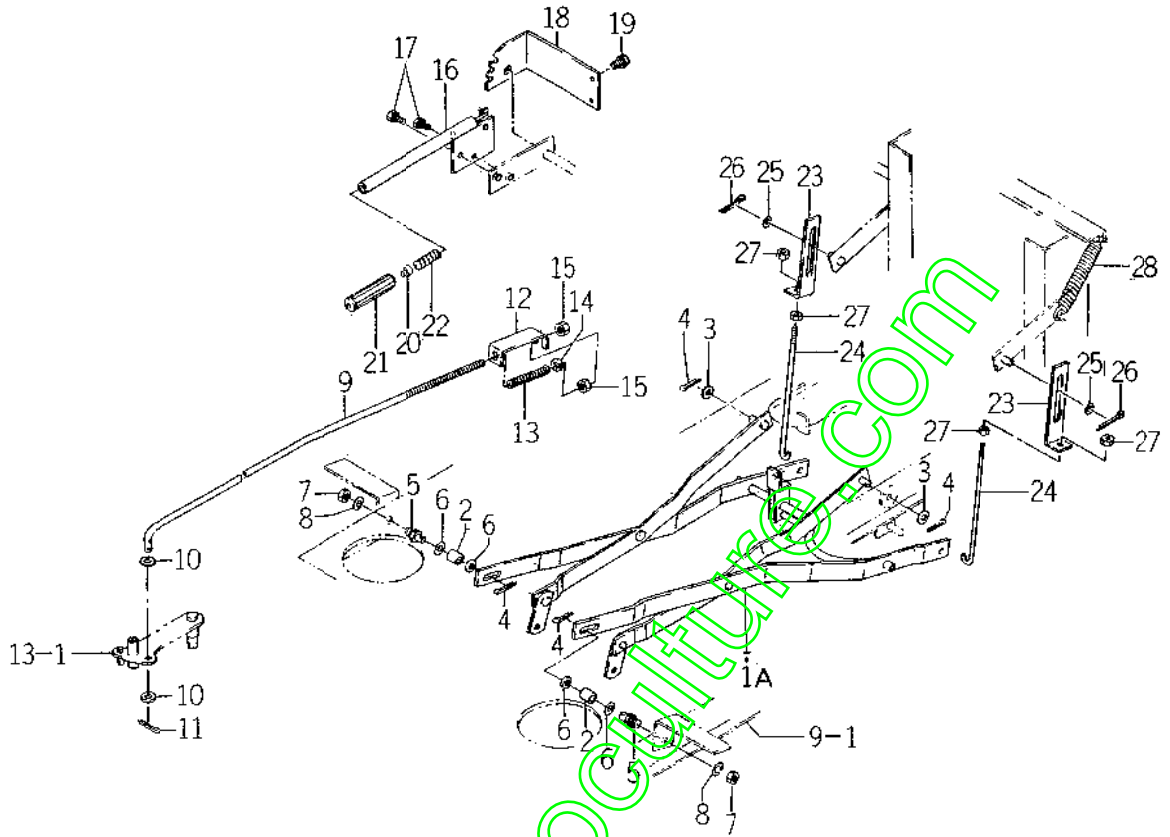

2502-555

KEY	PART CODE	DESCRIPTION	QTY	TYPE OF MODEL			REMARKS
				SL14H	I T C	C O L	
1	2502 - 553 - 210 - 30	LINK COMP	1	1-790			
1A	2502 - 553 - 210 - 40	LINK COMP	1	791-			
2	2502 - 553 - 001 - 20	COLLAR/11X15X07	2	*			
3	V411 - 260 - 012 - 00	WASHER/M12	2	*			
4	V500 - 162 - 502 - 50	PIN,SPLIT/2.5X25	4	*			
5	2502 - 553 - 003 - 10	PIN/M12X43	2	*			
5	3750 - 242 - 008 - 00	WASHER,ROOT TENSION	4	*			
7	V304 - 260 - 012 - 00	NUT/M12	2	*			
8	V401 - 160 - 012 - 00	WASHER,SP/M12	2	*			
9	2502 - 553 - 002 - 10	ROD/M08X751	1	*			
10	V411 - 260 - 008 - 00	WASHER,PL/M 8	2	*			
11	V500 - 162 - 502 - 50	PIN,SPLIT/2.5X25	1	*			
12	2502 - 553 - 004 - 00	PLATE,U/79X22	1	*			
13	2710 - 206 - 025 - 00	SPRING,RETURN	1	*			
14	V411 - 260 - 008 - 00	WASHER,PL/M 8	1	*			
15	V304 - 260 - 008 - 00	NUT/M 8	2	*			
16	2502 - 554 - 210 - 40	LEVER,LIFT COMP	1	*			
17	V211 - 560 - 802 - 50	BOLT,SEMS/M8X25 7T	2	*			
18	2502 - 554 - 008 - 10	PLATE	1	*			
19	V211 - 560 - 802 - 50	BOLT,SEMS/M8X25 7T	2	*			
20	2502 - 554 - 003 - 10	PIN,PUSH	1	*			
21	2502 - 554 - 004 - 10	GRIP,LIFT	1	*			
22	2502 - 554 - 007 - 00	SPRING/HCO57	1	*			
23	2502 - 554 - 001 - 10	PLATE,L/32X154	2	*			
24	2502 - 554 - 005 - 20	ROD/M10X246	2	*			

FIG. 15 HOOD AND PANEL SYSTEM

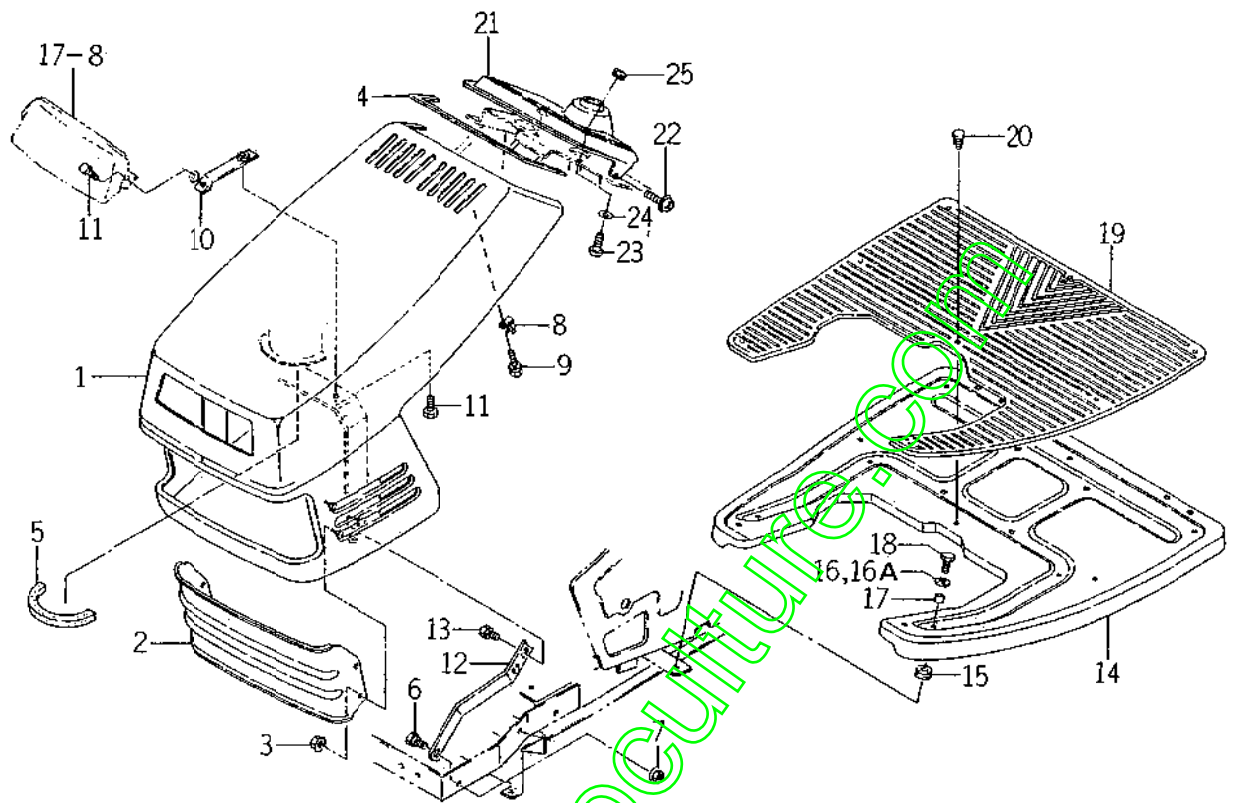

2502-601

KEY	PART CODE	DESCRIPTION	QTY	TYPE OF MODEL		I T C	C O L	G R P	REMARKS
				SL14H					
1	2502 - 601 - 210 - 40	HOOD COMP	1	*					
2	2502 - 601 - 001 - 20	COVER,FRONT	1	*					
3	V360 - 260 - 006 - 00	NUT/M6	4	*					
4	2502 - 601 - 006 - 00	TRIM/1X06X540	1	*					
5	2502 - 601 - 002 - 00	SEAL 15X15X320	1	*					
6	2502 - 601 - 003 - 00	BOLT/M08X20	2	*					
7	2502 - 601 - 005 - 00	NUT/M08	2	*					
8	3610 - 631 - 002 - 00	HANGER,SUPPORT	2	*					
9	V211 - 260 - 801 - 20	BOLT,SEMS (3) M8X12	2	*					
10	2502 - 601 - 220 - 30	PLATE COMP	2	*					
11	V210 - 260 - 601 - 60	BOLT,SEMS (S)	2	*					
12	2502 - 601 - 004 - 10	ARM,HOOD	2	*					
13	V211 - 260 - 801 - 60	BOLT,SEMS (S) M8X16	4	*					
14	2502 - 616 - 001 - 40	STEP	1	*					
15	1414 - 606 - 002 - 00	GROMMET/12X19	6	*					
16	1444 - 601 - 011 - 00	WASHER (9X24X1.6)	6	1- -2355 2356-					
16A	3560 - 201 - 015 - 00	WASHER	6						
17	2502 - 616 - 004 - 00	COLLAR/08X2X10	6	*					
18	V201 - 260 - 802 - 50	BOLT/M 8X25	6	*					
19	2502 - 616 - 002 - 20	MAT	1	*					
20	1527 - 604 - 002 - 00	CLIP (B)	8	*					
21	2502 - 621 - 001 - 00	PANEL,INSTRUMENT	1	*					
22	V120 - 266 - 001 - 60	SCREW SEEMS/M6X16	2	*					
23	1581 - 740 - 116 - 00	SCREW/M6X20	2	*					
24	1593 - 601 - 073 - 00	WASHER/06X16X01	2	*					

FIG. 15 HOOD AND PANEL SYSTEM

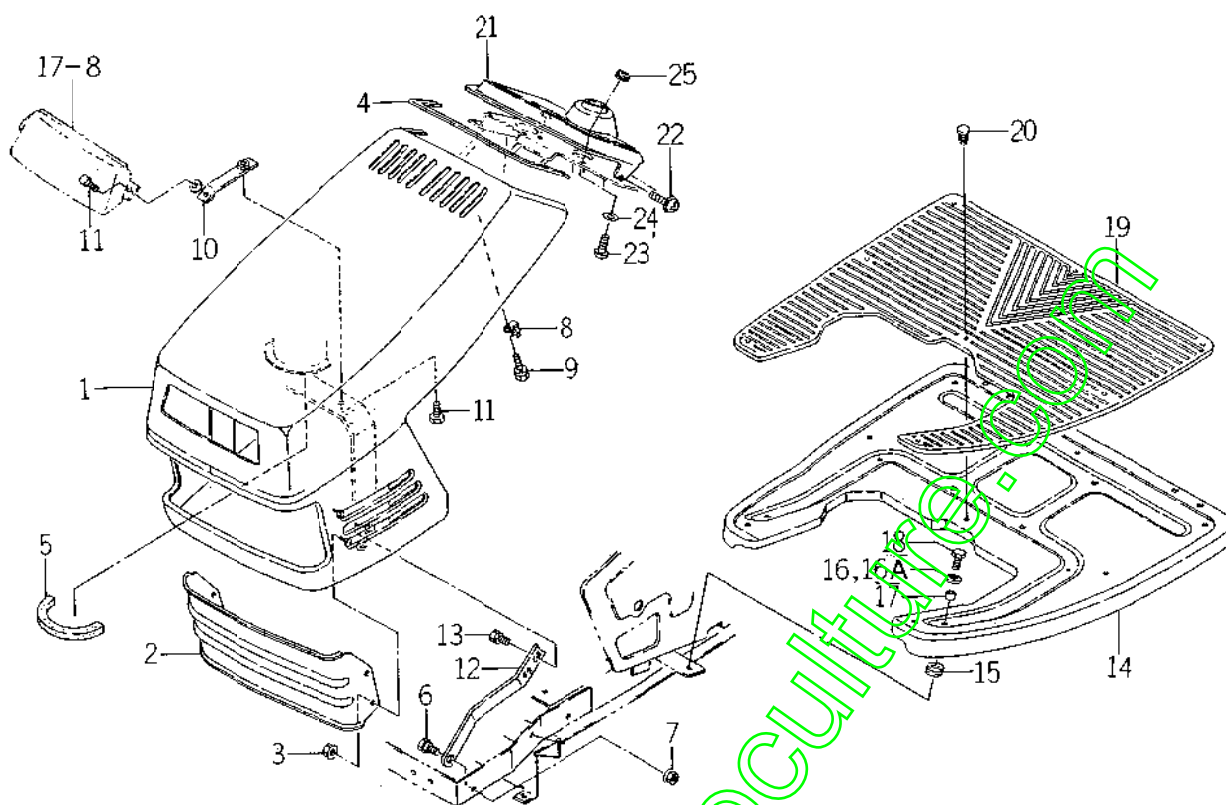

2502-621

KEY	PART CODE	DESCRIPTION	QTY	TYPE OF MODEL		I T C	C O L	G R P	REMARKS
				SL14H					
25	1427 - 621 - 012 - 00	GROMMET	1	*					

www.emc-motoculture.com

FIG. 16 FENDER AND SEAT SYSTEM

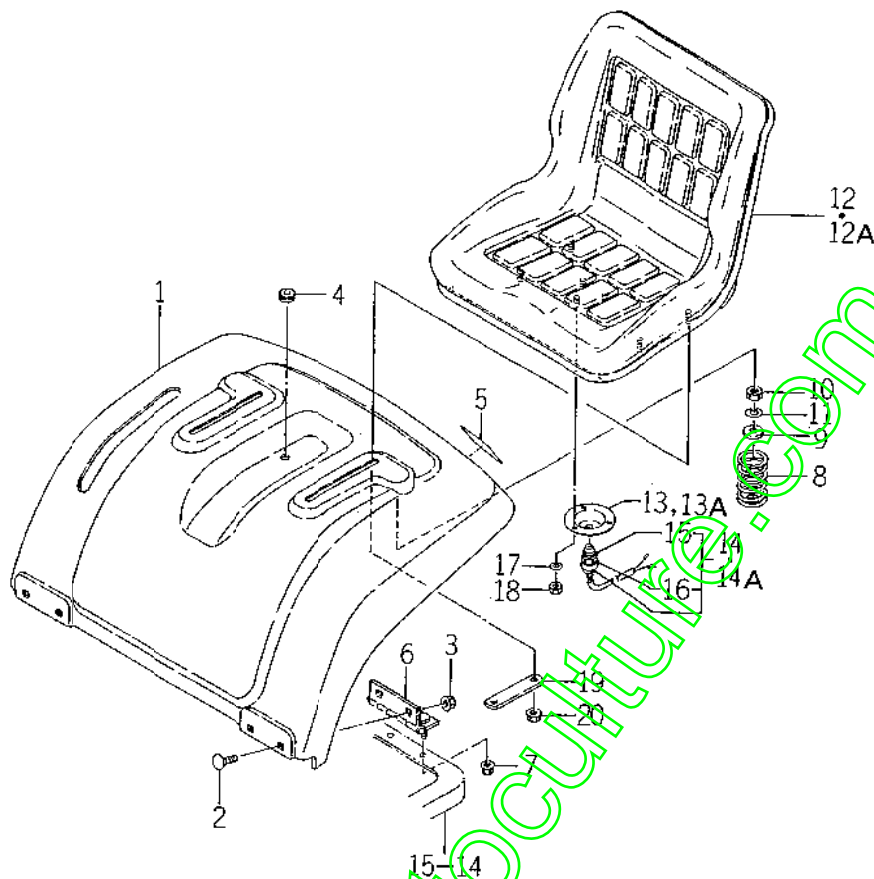

2502-506

KEY	PART CODE	DESCRIPTION	QTY	TYPE OF MODEL		I T C	C O L	G R P	REMARKS
				SL14H					
1	2502 - 606 - 003 - 10	FENDER	1	*					
2	2502 - 606 - 002 - 00	BOLT/M06X16	4	*					
3	V360 - 230 - 006 - 00	NUT/M6	4	*					
4	1427 - 621 - 0'2 - 00	GROMMET	1	*					
5	2502 - 606 - 001 - 00	REFLECTER	2	*					
6	2502 - 606 - 220 - 10	HINGE/T02	2	*	COMP				
7	V363 - 260 - 008 - 00	NUT_LOCK/M8	4	*					
8	1593 - 611 - 014 - 00	SPRING/D=6	2	*					
9	1376 - 606 - 005 - 00	WASHER/9X32X2	2	*					
10	V304 - 260 - 008 - 00	NUT/M 8	2	*					
11	V401 - 160 - 008 - 00	WASHER,SP/M 8	2	*					
12	2502 - 611 - 270 - 00	SEAT	1	1-	ASSY				
12A	2502 - 611 - 270 - 10	SEAT	1	1991-	ASSY				
13	1593 - 611 - 011 - 10	HOLDER/SWITCH	1	1-					
13A	1593 - 611 - 011 - 20	HOLDER/SWITCH	1	1991-					
14	1593 - 623 - 270 - 00	SWITCH,SEAT ASSY	1	1-					
14A	1593 - 623 - 270 - 10	SWITCH,SEAT ASSY	1	100000					
15	1593 - 623 - 272 - 00	BOOT	1	*					
16	1593 - 623 - 273 - 00	NUT	1	*					
17	V401 - 160 - 006 - 00	S.W	3	*					
18	V301 - 260 - 006 - 00	NUT/M 6	3	*					
19	2502 - 611 - 001 - 00	PLATE	2	*					
20	V362 - 260 - 008 - 00	NUT	4	*					

FIG. 17 ELECTRICAL SYSTEM

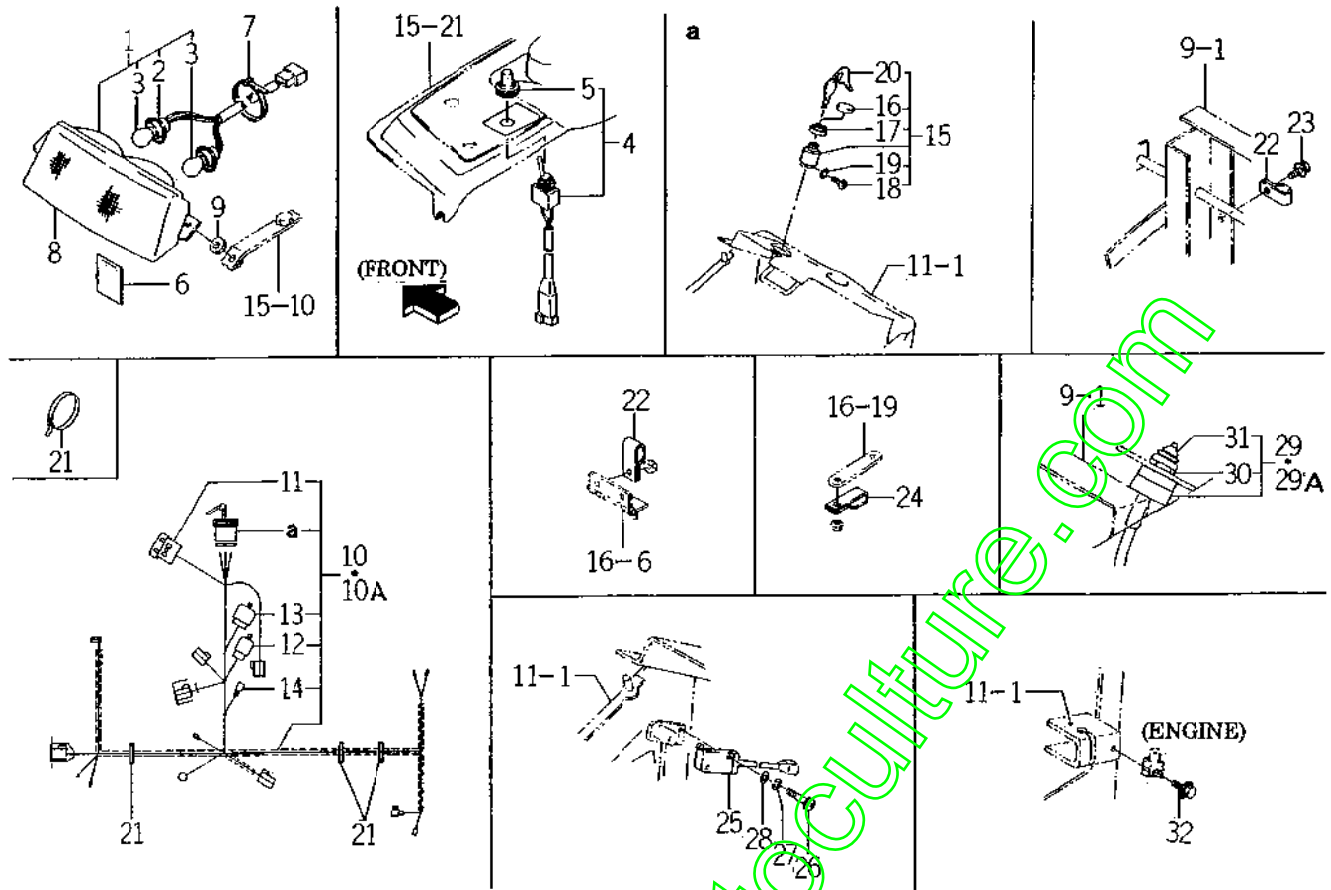

1593-622B

KEY	PART CODE	DESCRIPTION	QTY	TYPE OF MODEL		I T C	C O L	G R P	REMARKS
				SL14H					
1	1593 - 622 - 250 - 00	LAMP,HEAD ASSY	1	T					
2	1593 - 622 - 240 - 00	LEAD	1	T					
3	1564 - 654 - 213 - 00	BULB,LAMP/12V2:W	2	T					
4	1593 - 622 - 270 - 00	SWITCH,HEAD LAMP	1	T					
5	3631 - 270 - 003 - 00	COVER,SWITCH	1	T					
6	1593 - 622 - 001 - 10	LABEL,SWITCH	1	T					
7	3737 - 172 - 010 - 00	BAND,HARNESS	3	T					
8	1593 - 622 - 211 - 10	LENS	1	*					
9	1444 - 601 - 015 - 00	WASHER/5X14X3	2	*					
10	2502 - 623 - 200 - 30	HARNESS,MAIN ASSY	1	1- -100000					
10A	2502 - 623 - 200 - 40	HARNESS,MAIN ASSY	1	100001-					
11	1575 - 623 - 010 - 00	FUSE /32V10A	2	*					
12	2500 - 623 - 220 - 00	RELAY,4P ASSY	1	*					
13	1593 - 623 - 530 - 00	RELAY,5P ASSY	1	*					
14	2502 - 623 - 202 - 00	DIODE/1.5A	1	*					
15	1386 - 624 - 330 - 00	SWITCH,STARTER SET	1	*					
16	1386 - 624 - 292 - 00	CAP	1	*					
17	1386 - 624 - 293 - 00	NUT,RING	1	*					
18	V111 - 164 - 000 - 60	SCREW M4X6	3	*					
19	V401 - 160 - 004 - 00	WASHER,SF/M 4	3	*					
20	1386 - 624 - 300 - 00	KEY ASSY	1	*					
21	3746 - 172 - 013 - 00	BAND,HARNESS	3	*					
22	1425 - 621 - 004 - 00	CLAMP,HARNESS	5	*					
23	V211 - 360 - 801 - 20	BOLT,SEMS	2	*					
24	3768 - 172 - 008 - 00	CLAMPER,7 LONG	1	*					

FIG. 18 ORNAMENT

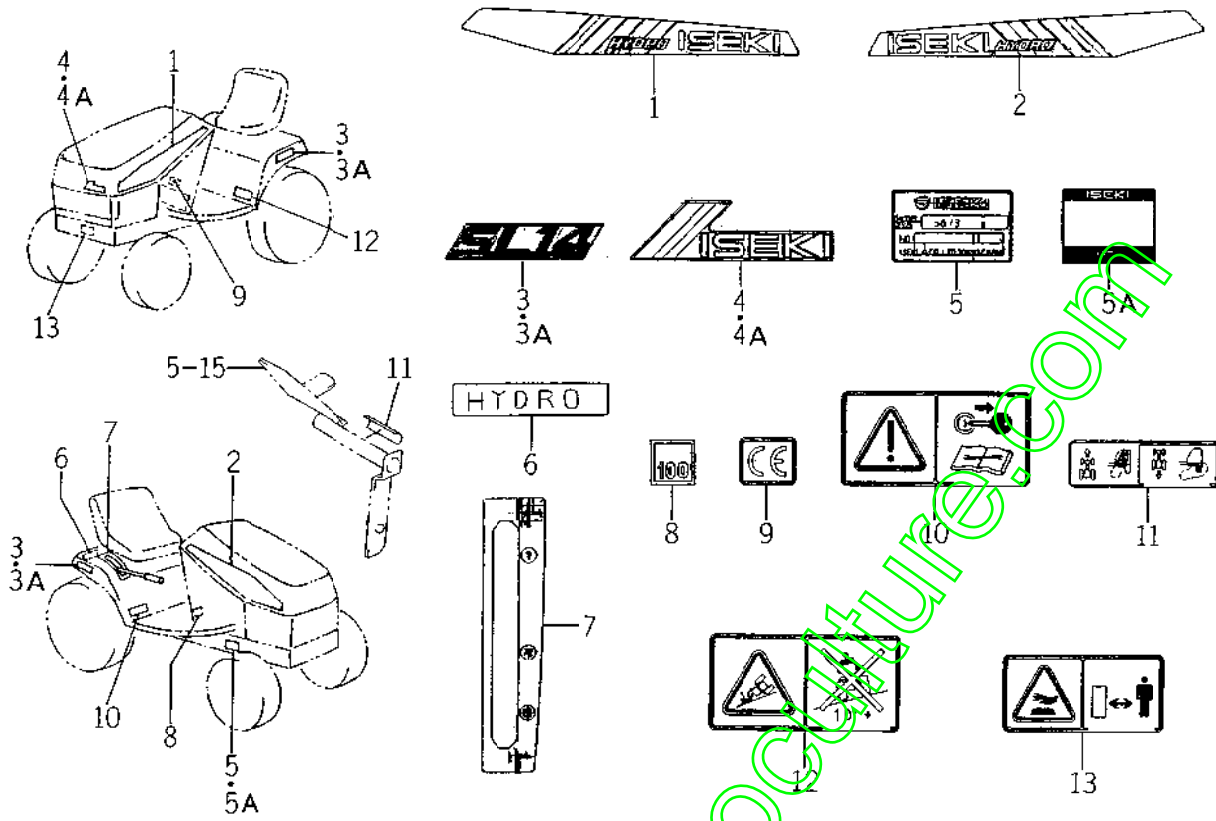

2502-001

KEY	PART CODE	DESCRIPTION	QTY	TYPE OF MODEL		I T C	C O L	G R P	REMARKS
				SL14H					
1	2502-901-001-20	ORNAMENT/LH	1	*					
2	2502-901-002-30	ORNAMENT/RH	1	*					
3	2502-901-003-00	ORNAMENT/14	2	1- -1990					
3A	2502-901-003-10	ORNAMENT/14	2	1991-					
4	2502-901-004-10	ORNAMENT/F	1	1- -1990					
4A	2502-901-004-20	ORNAMENT/F	1	1991-					
5	2502-901-006-10	LABEL,MODEL/SL14	1	1- -100000					
5A		LABEL,MODEL ASSY	1	100001-					
6	1608-901-004-00	ORNAMENT (HYDRAULIC)	1	*					
7	2502-901-007-00	LABEL,IFT LEVER	1	*					
8	2500-901-008-00	LABEL,NOZZLE/100	1	*					
9	2500-901-027-00	LABEL/CE	1	*					
10	1593-901-015-00	LABEL/MENTENANSU	1	*					
11	2502-901-008-00	LABEL/HST	1	*					
12	1636-901-015-00	LABEL/CAUTION/SROOP	1	*					
13	8595-901-007-00	LABELCAUTION/HOT	1	*					

FIG. 19 LABEL

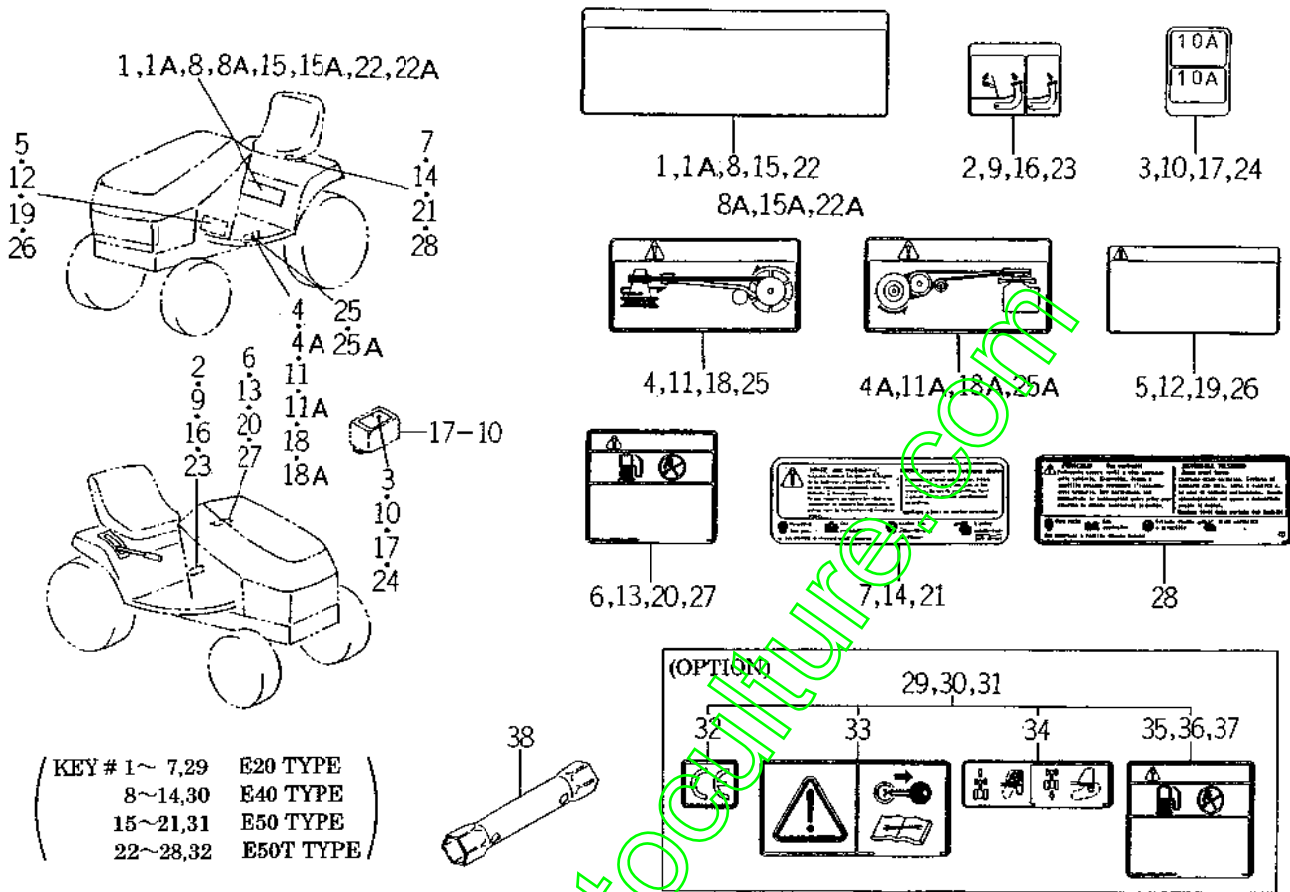

2502-906

KEY	PART CODE	DESCRIPTION	QTY	TYPE OF MODEL		I T C	C O L	G R P	REMARKS
				SL14H					
1	2502-905-001-00	LABEL,OPERATION/D	1	1- -1999 2000-					
1A	2502-905-001-10	LABEL,OPERATION/D	1	*					
2	2502-905-002-00	LABEL,PARKING/D	1	*					
3	2502-905-003-00	LABEL,FUSE/D	1	*					
4	2502-905-004-00	LABEL,BELT CAUTION/D	1	1- -790 791-					
4A	2502-905-006-00	LABEL,BELT CAUTION/D	1	*					
5	2502-905-005-00	LABEL,CAUTION/D	1	*					
6	2502-905-021-00	LABEL/D/FUEL/D	1	*					
7	1640-903-036-00	LABEL/D/BATTERY	1	*					
8	2502-906-001-00	LABEL,PARKING/E	1	1- -2347 2348-					
8A	2502-906-001-20	LABEL,OPERATION/E	1	*					
9	2502-906-002-00	LABEL,PARKING/E	1	*					
10	2502-906-003-20	LABEL,FUSE/E	1	*					
11	2502-906-004-00	LABEL,BELT CAUTION/E	1	1- -790 791-					
11A	2502-906-006-00	LABEL,BELT CAUTION/E	1	*					
12	2502-906-005-00	LABEL,CAUTION/E	1	*					
13	2502-906-021-00	LABEL/D/FUEL/G	1	*					
14	1640-904-016-00	LABEL/D/BATTERY	1	*					
15	2502-907-001-00	LABEL,OPERATION/F	1	1- -1999 2000-					
15A	2502-907-001-10	LABEL,OPERATION/F	1	*					
16	2502-907-002-00	LABEL,PARKING/F	1	*					
17	2502-907-003-00	LABEL,FUSE/F	1	*					
18	2502-907-004-00	LABEL,BELT CAUTION/F	1	1- -790 791-					
18A	2502-907-006-00	LABEL,BELT CAUTION/F	1	*					
19	2502-907-005-00	LABEL,OPTION/E	1	*					

FIG. 19 LABEL

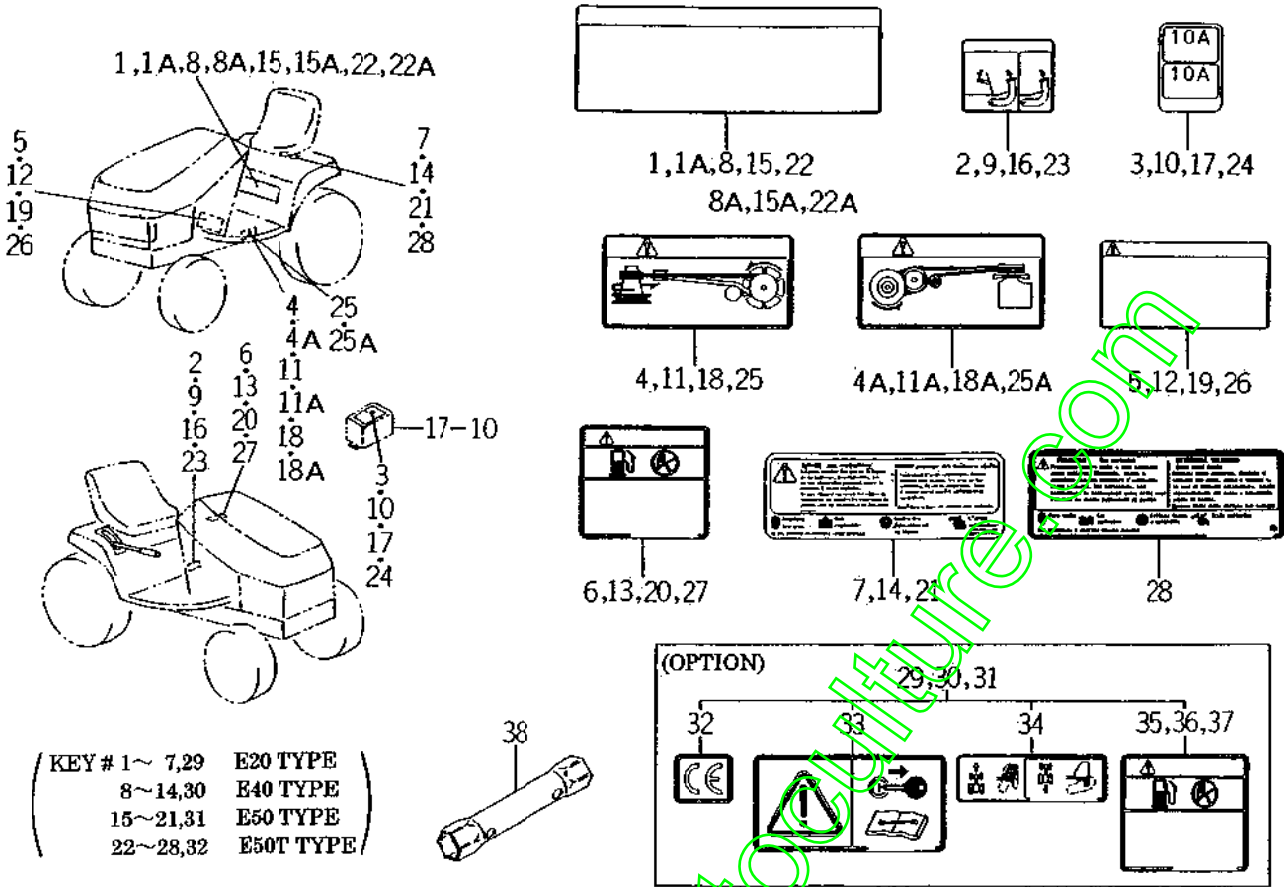

2502-907

KEY	PART CODE	DESCRIPTION	QTY	TYPE OF MODEL		I T C	C O L	G R P	REMARKS
				SL14H					
20	2502 - 907 - 021 - 00	LABEL/D/FUEL/F	1	*					
21	1640 - 903 - 016 - 00	LABEL/D/BATTERY	1	*					
22	2502 - 910 - 001 - 00	LABEL,OPERATION/I	1	1- -1994					
22A	2502 - 910 - 001 - 10	LABEL,OPERATION/I	1	1995-					
23	2502 - 910 - 002 - 00	LABEL/PARKING/I	1	*					
24	2502 - 910 - 003 - 00	LABEL/FUSE/I	1	*					
25	2502 - 910 - 004 - 00	LABEL,BELT CAUTION/I	1	1- -790					
25A	2502 - 910 - 006 - 00	LABEL,BELT CAUTION/I	1	791-					
26	2502 - 910 - 005 - 00	LABEL/CAUTION/I	1	*					
27	2502 - 910 - 021 - 00	LABEL/D/FUEL/T	1	*					
28	1640 - 905 - 016 - 00	LABEL CAUTION/BATTERY	1	*					
29	2502 - 905 - 200 - 00	LABEL/SL/D SET	1	T					
30	2502 - 906 - 200 - 00	LABEL/SL/G SET	1	T					
31	2502 - 907 - 200 - 00	LABEL/SL/F SET	1	T					
32	2500 - 901 - 027 - 00	LABEL/CE	1	T					
33	1593 - 901 - 015 - 00	LABEL/MENTENANSU	1	T					
34	2502 - 901 - 008 - 00	LABEL/HST	1	T					
35	2502 - 905 - 021 - 00	LABEL/D/FUEL/D	1	T					
36	2502 - 906 - 021 - 00	LABEL/D/FUEL/G	1	T					
37	2502 - 907 - 021 - 00	LABEL/D/FUEL/F	1	T					
38	2500 - 930 - 001 - 00	WRENCH/PLUG	1	*					

FIG. 20 DRIVING SYSTEM

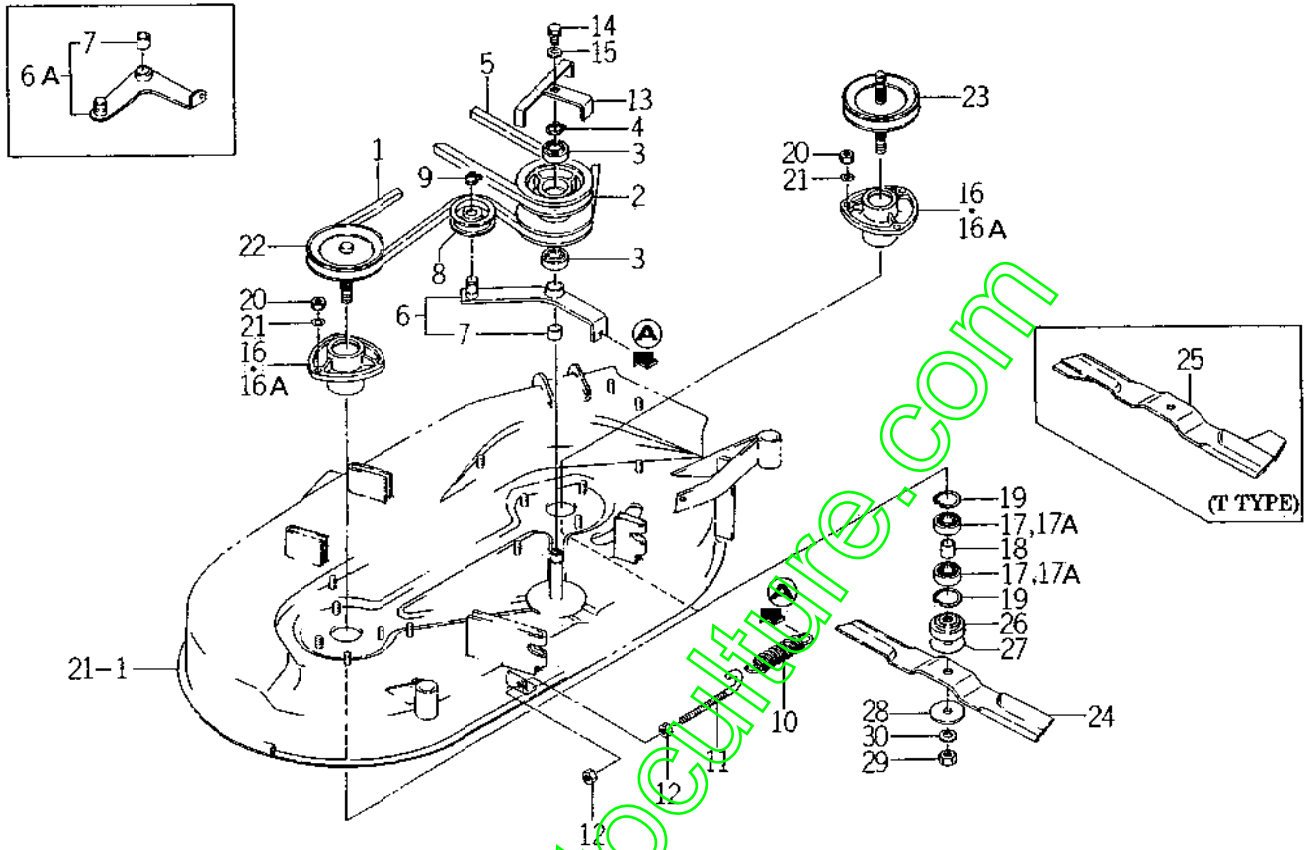

8650-101

KEY	PART CODE	DESCRIPTION	QTY	TYPE OF MODEL		I T C	C O L	G R P	REMARKS
				SSM40					
1	8650 - 101 - 002 - 00	BELT/VB066	1	*					
2	8650 - 201 - 001 - 10	PULLEY/V2B120	1	*					
3	8650 - 201 - 002 - 00	BEARING, RB	2	*					
4	V704 - 140 - 020 - 00	RING, SNAP / 20	1	*					
5	8650 - 101 - 001 - 10	BELT / VB066	1	*					
6	8650 - 203 - 200 - 10	ARM, TENSION ASSY	1	1- -790 791-					
6A	8650 - 203 - 200 - 20	ARM, TENSION ASSY	1						
7	8650 - 203 - 001 - 10	BUSH / 20X23X20	1	*					
8	8593 - 014 - 200 - 10	PULLEY / FT / 85X22 COMP	1	*					
9	V704 - 140 - 017 - 80	RING, SNAP / 17 C	1	*					
10	3737 - 341 - 006 - 00	SPRING, CHAIN TENSION	1	*					
11	3737 - 341 - 007 - 00	ROD	1	*					
12	V304 - 260 - 008 - 00	NUT / M 8	2	*					
13	8650 - 204 - 210 - 10	GUIDE, BELT COMP	1	*					
14	V211 - 260 - 802 - 00	BOLT, SEMS (S)	1	*					
15	2130 - 407 - 003 - 00	WASHER, CAM	1	*					
16	8595 - 301 - 001 - 70	METAL	2	1- -200000 200001-					
16A	8595 - 301 - 001 - 80	METAL	2						
17	8595 - 301 - 008 - 00	BEARING, RB	4	1- -790 791-					
17A	8595 - 301 - 008 - 10	BEARING, RB	4						
18	8595 - 301 - 004 - 30	HUB / 18X22X20	2	*					
19	V705 - 140 - 040 - 00	RING, SNAP / 40 C	4	*					
20	V304 - 260 - 008 - 00	NUT / M 8	6	*					
21	V401 - 160 - 008 - 00	WASHER, SP / M 8	6	*					
22	8595 - 301 - 500 - 50	PULLEY / VB120 COMP	1	*					

FIG. 21 DECK AND COVER SYSTEM

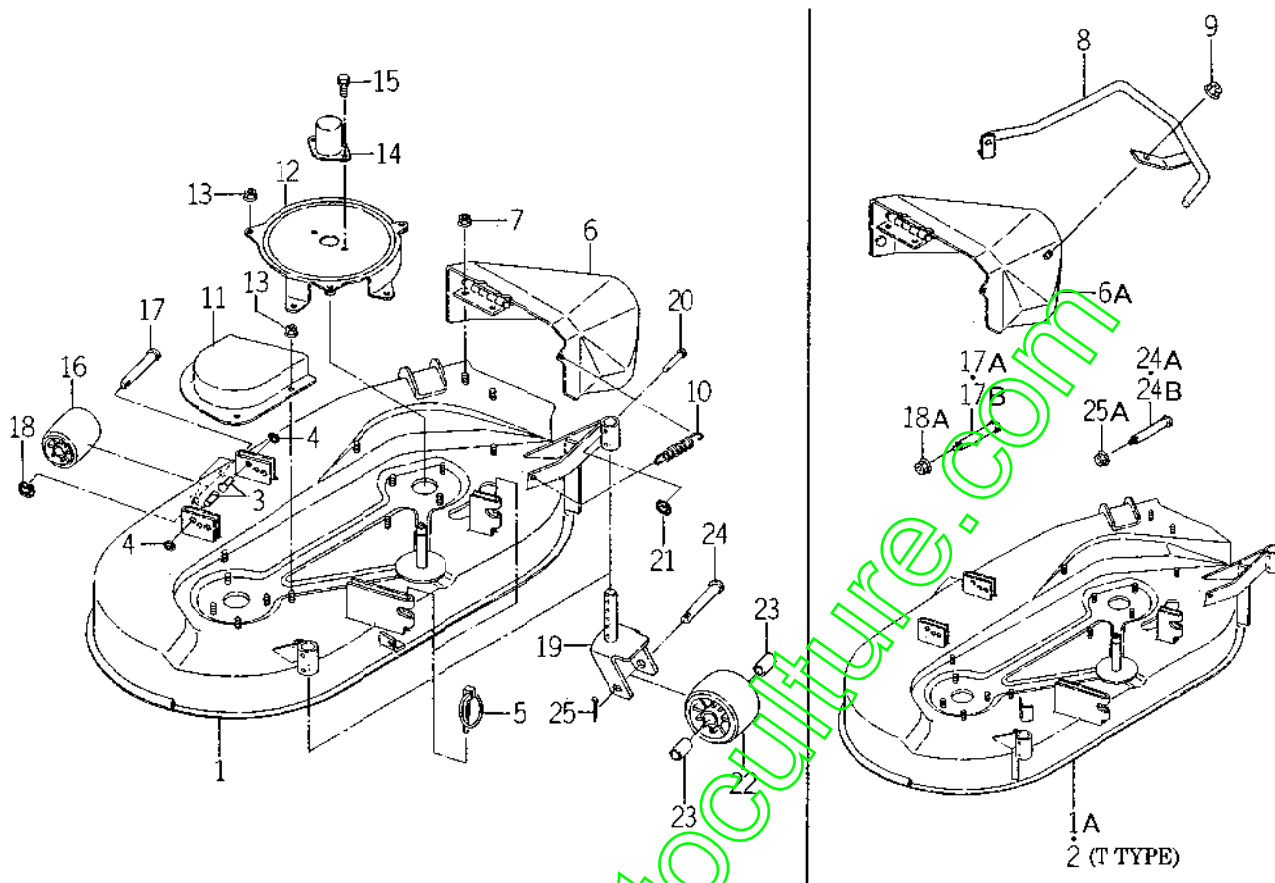

8650-401

KEY	PART CODE	DESCRIPTION	QTY	TYPE OF MODEL		I T C	C O L	G R P	REMARKS
				SSM40					
1	8650 - 401 - 210 - 30	DECK,MOWER/40 COMP	1	1-					
1A	8650 - 401 - 210 - 40	DEK,MOWER/40 COMP	1	-790					
2	8650 - 401 - 250 - 00	DEK,MOWER/40 COMP	1	*					
3	8650 - 401 - 001 - 10	PIN/12X22	2	*					
4	1427 - 317 - 003 - 00	CLIP,PIN	2	*					
5	8595 - 405 - 500 - 20	PIN,STOPPER ASSY	2	*					
6	8650 - 402 - 210 - 10	COVER,DISCHARGE COMP	1	1-					
6A	8650 - 402 - 210 - 20	COVER,DISCHARGE COMP	1	-200000					
7	V363 - 260 - 008 - 00	NUT,LOCK/M8	2	200001-					
8	8650 - 402 - 220 - 00	GUIDE,DISCHARGE COMP	1	*					
9	V363 - 260 - 008 - 00	NUT,LOCK/M8	2	*					
10	3768 - 1'2 - 001 - 00	SPRING,CLUTCH RETURN	1	*					
11	8650 - 403 - 001 - 10	COVER,PULLEY/LH	1	*					
12	8650 - 403 - 210 - 10	COVER,PULLEY/RH COMP	1	*					
13	V363 - 260 - 008 - 00	NUT,LOCK/M8	7	*					
14	1427 - 130 - 260 - 00	CAP,SHAFT (A) COMP	1	*					
15	V211 - 260 - 801 - 20	BOLT,SEMS (S) M8X12	2	*					
16	8595 - 501 - 001 - 10	WHEEL,GAUGE FRONT	1	*					
17	8595 - 505 - 051 - 00	PIN/12X104	1	1-					
17A	8595 - 505 - 051 - 10	PIN/12X108	1	-1889					
17B	8595 - 505 - 051 - 20	PIN/12X108	1	1990-					
18	1427 - 317 - 003 - 00	CLIP,PIN	1	-2520					
18A	V363 - 260 - 008 - 00	NUT,LOCK/M8	1	2521-					
19	8650 - 502 - 210 - 00	FORK,WHEEL COMP	2	1-					
20	8595 - 505 - 002 - 00	PIN/08X44	2	-1889					
				-1990-					

FIG. 22 LABEL

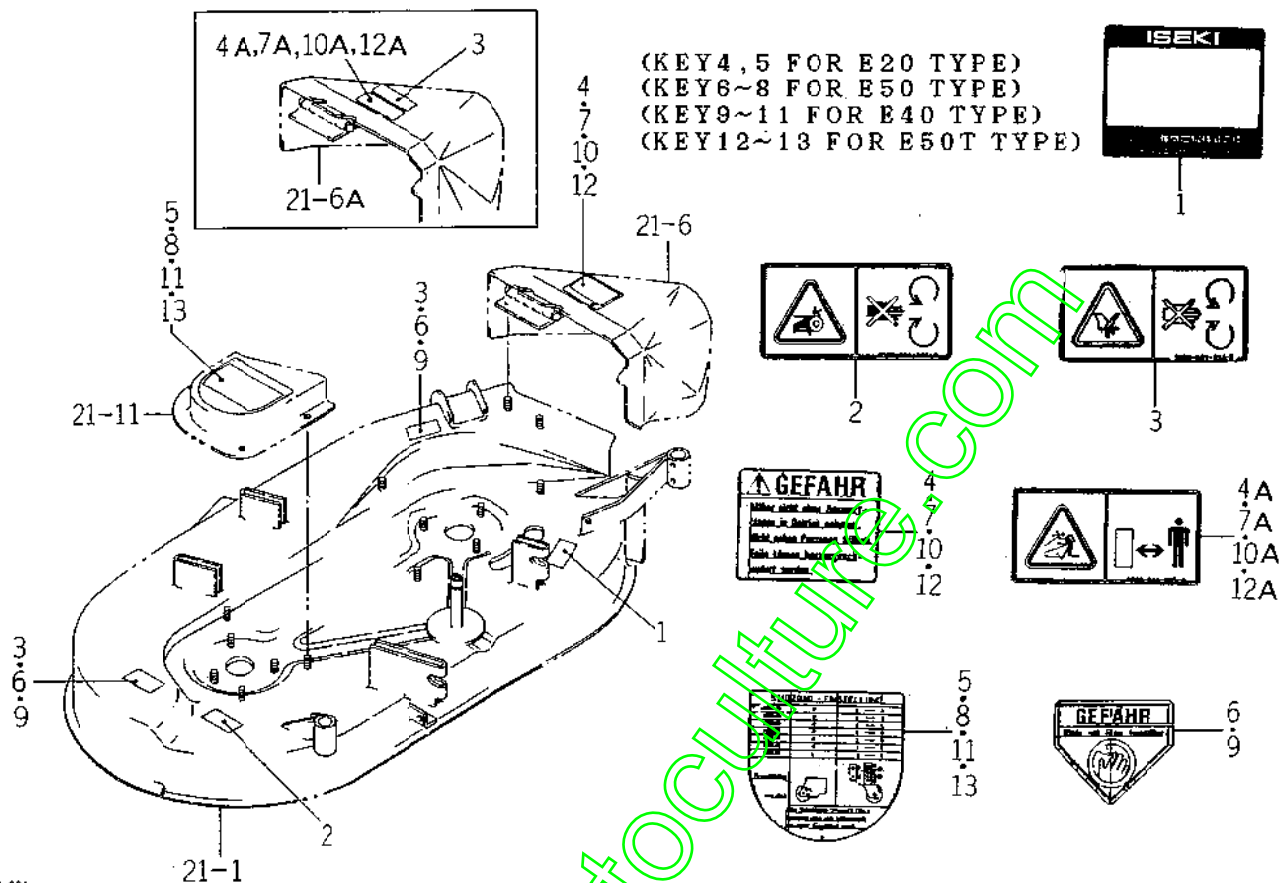

8651-901

KEY	PART CODE	DESCRIPTION	QTY	TYPE OF MODEL		I T C	C O L	G R P	REMARKS
				SSM40					
1		LABEL,MODEL ASSY	1	*					
2	8595 - 901 - 006 - 00	LABEL/CAUTION/BELT	1	*					
3	2500 - 901 - 014 - 30	LABEL/DISCHARGE	3	*					
4	8595 - 901 - 003 - 00	LABEL,DISCHARGE/D	1	1- -200000					
4A	8595 - 901 - 005 - 00	LABEL,DISCHARGE	1	200001-					
5	8650 - 901 - 002 - 00	LABEL,GAUGE WHEEL/D	1	*					
6	8595 - 902 - 001 - 10	LABEL (DANGER/F)	2	*					
7	8595 - 902 - 002 - 00	LABEL,DISCHARGE/F	1	1- -100000					
7A	8595 - 901 - 005 - 00	LABEL,DISCHARGE	1	100001-					
8	8650 - 902 - 001 - 00	LABEL,GAUGE WHEEL/F	1	*					
9	8595 - 903 - 001 - 00	LABEL	2	*					
10	8595 - 903 - 002 - 00	LABEL	1	1- -100000					
10A	8595 - 901 - 005 - 00	LABEL,DISCHARGE	1	100001-					
11	8650 - 903 - 001 - 00	LABEL,GAUGE WHEEL/E	1	*					
12	8650 - 910 - 002 - 00	LABEL/DISCHARGE	1	1- -200000					
12A	8595 - 901 - 005 - 00	LABEL,DISCHARGE	1	200001-					
13	8650 - 910 - 001 - 00	LABEL/WHEEL,GAUGE/I	1	*					

FIG. 23 FAN AND COVER SYSTEM

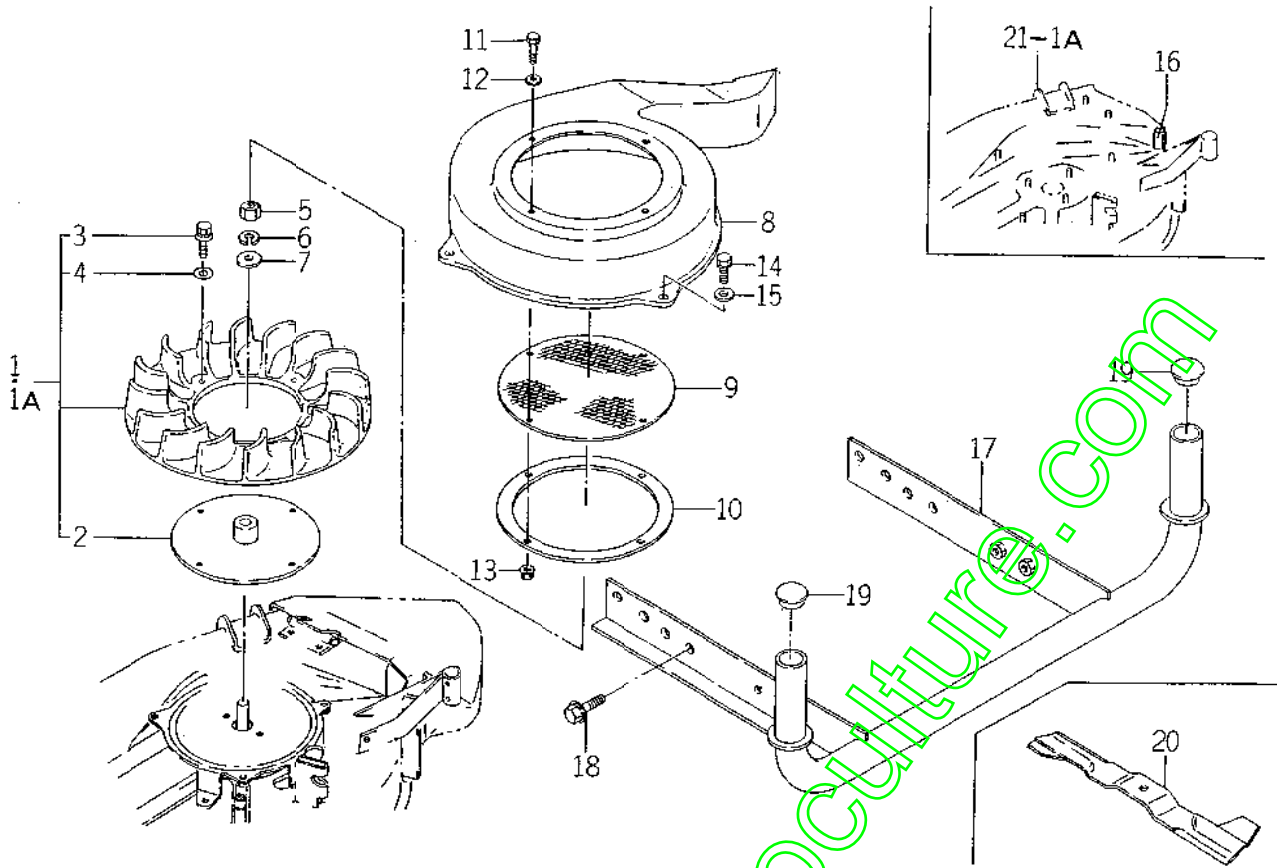

8651-101

KEY	PART CODE	DESCRIPTION	QTY	TYPE OF MODEL		I T C	C O L	G R P	REMARKS
				SBC250					
1	8651 - 101 - 200 - 00	FAN,SHIRKO ASSY	1	1-					
1A	8651 - 101 - 200 - 10	FAN	1	-5					
2	8651 - 101 - 210 - 10	HJB COMP	1	6-					
3	V210 - 360 - 601 - 60	BOLT (SP) /M6X16	4	*					
4	3761 - 212 - 004 - 00	WASHER,HOLDER COVER	4	*					
5	V304 - 260 - 014 - 00	NUT/M14	1	*					
6	V401 - 160 - 014 - 00	WASHER,SP /M14	1	*					
7	V411 - 260 - 014 - 00	WASHER,PL /M14	1	*					
8	8651 - 102 - 201 - 00	CASE,FAN	1	*					
9	8651 - 102 - 202 - 00	NET,FAN	1	*					
10	8651 - 102 - 203 - 00	PLATE,FAN	1	*					
11	V200 - 260 - 601 - 60	BOLT /M 6X16	4	*					
12	3567 - 402 - 004 - 00	WASHER,THROWER	4	*					
13	V361 - 260 - 006 - 00	NUT	4	*					
14	V211 - 560 - 802 - 00	BOLT /M8X20	2	*					
15	1373 - 121 - 001 - 00	WASHER /9X22X2	2	*					
16	8651 - 102 - 001 - 00	SEAL /20X20X70	1	*					
17	8651 - 201 - 210 - 10	HITCH,COLLECTOR COMP	1	*					
18	V211 - 361 - 002 - 50	BOLT /M10X25	4	*					
19	3615 - 820 - 003 - 00	PLUG	2	*					
20	8651 - 103 - 210 - 00	BLADE /57X514 COMP	2	*					

FIG. 24 PANEL AND FRAME SYSTEM

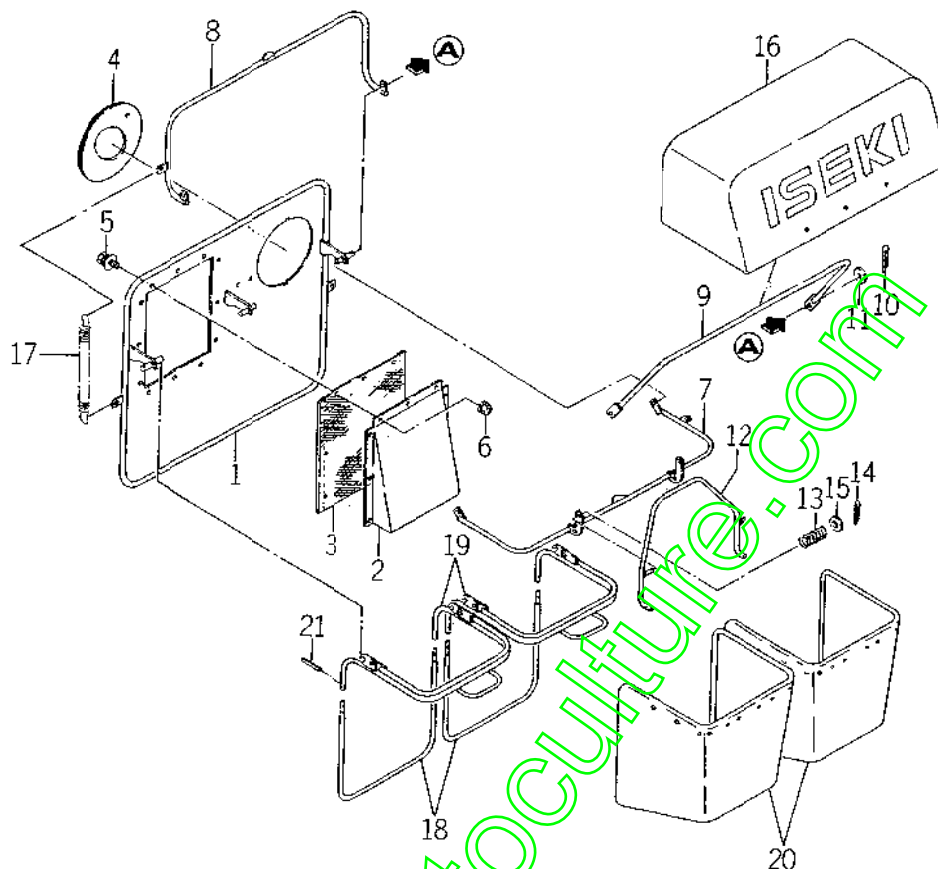

8651-202

KEY	PART CODE	DESCRIPTION	QTY	TYPE OF MODEL		I T C	C O L	G R P	REMARKS
				SBC250					
1	8651 - 202 - 210 - 10	PANEL,CONNECTOR COMP	1	*					
2	8651 - 202 - 201 - 00	COVER,PANEL	1	*					
3	8651 - 202 - 202 - 00	NET,PANEL	1	*					
4	8651 - 202 - 001 - 00	GROMMET,PANEL	1	*					
5	V210 - 360 - 601 - 60	BOLT (SP) M6X16	11	*					
6	V361 - 260 - 006 - 00	NUT	12	*					
7	8651 - 203 - 210 - 20	FRAME/A COMP	1	*					
8	8651 - 203 - 220 - 00	FRAME/B COMP	1	*					
9	8651 - 203 - 250 - 00	FRAME/C COMP	1	*					
10	V500 - 163 - 002 - 00	PIN,SPLIT/3 X20	2	*					
11	V411 - 260 - 012 - 00	WASHER /M12	2	*					
12	8651 - 203 - 230 - 00	LEVER,FRAME COMP	1	*					
13	2130 - 525 - 001 - 10	SPRING	1	*					
14	V500 - 163 - 002 - 00	PIN,SPLIT/3 X20	1	*					
15	V411 - 260 - 012 - 00	WASHER /M12	1	*					
16	8651 - 203 - 240 - 00	COVER,CONNECTOR COMP	1	*					
17	3614 - 820 - 004 - 00	SPRING,SHUTTER	1	*					
18	8651 - 204 - 201 - 00	FRAME	2	*					
19	8651 - 204 - 210 - 00	FRAME,BAG COMP	2	*					
20	8651 - 204 - 220 - 00	BAG,COLLECTOR COMP	2	*					
21	V580 - 140 - 402 - 00	PIN,SPRING/4 X20 W	4	*					

FIG. 25 COVER AND PIPE SYSTEM

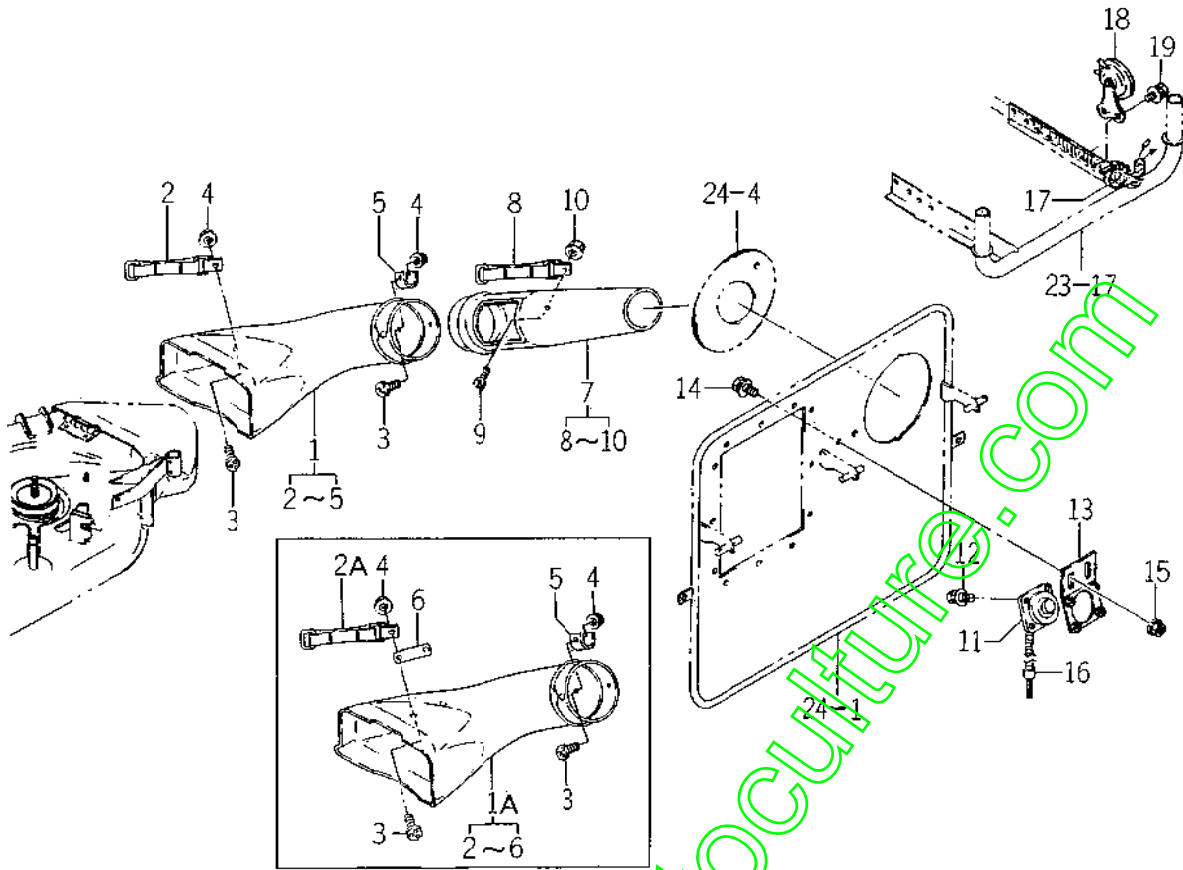

8651-301

KEY	PART CODE	DESCRIPTION	QTY	TYPE OF MODEL		I T C	C O L	G R P	REMARKS
				SBC250					
1	8651-301-200-20	COVER,SHOOTER ASSY	1	1- -200000 200001-					
1A	8651-301-200-30	COVER,SHOOTER ASSY	1	1- -1250 1251-					
2	8651-301-210-10	HOLDER,BAND COMP	1	*					
2A	8651-301-230-00	BAND,SHUTER ASSY	1	*					
3	8651-301-202-00	BOLT/M8X16	3	*					
4	V363-260-008-00	NUT,LOCK/M8	3	*					
5	8651-301-211-10	HOLDER,BAND	1	*					
6	8651-301-203-00	PLATE/IR/54X156	1	*					
7	8651-302-200-00	PIPE,SHOOTER ASSY	1	*					
8	8651-302-210-10	PIPE,SHUTER COMP	1	*					
9	8651-301-202-00	BOLT/M8X16	1	*					
10	V363-260-008-00	NUT LOCK/M8	1	*					
11	8651-601-200-10	SENSOR ASSY	1	*					
12	V210-360-601-60	BOLT (SP) /M6X16	2	*					
13	3615-820-240-10	PLATE	1	*					
14	V210-360-601-60	BOLT (SP) /M6X16	2	*					
15	V361-260-006-00	NUT	2	*					
16	8651-601-210-00	HARNES,SENSOR ASSY	1	*					
17	1342-402-006-00	BAND,WIRE/250	2	*					
18	3656-271-290-10	HORN ASSY	1	*					
19	V210-360-601-60	BOLT (SP) /M6X16	2	*					

FIG. 26 LABEL

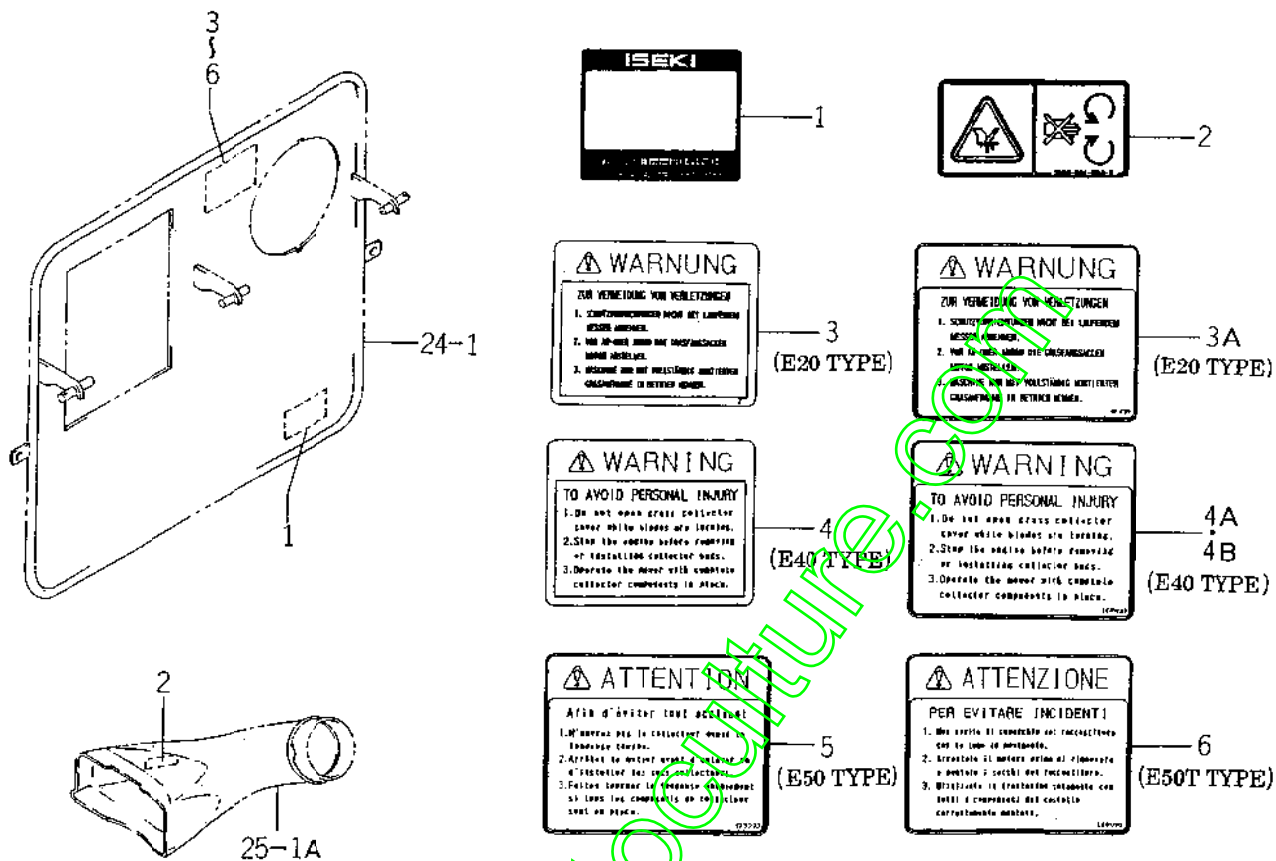

8651-901

KEY	PART CODE	DESCRIPTION	QTY	TYPE OF MODEL		I T C	C O L	G R P	REMARKS
				SBC250					
1		LABEL,MODEL ASSY	1	*					
2	2500 - 901 - 014 - 30	LABEL/DISCHARGE	1	*					
3	8651 - 901 - 002 - 00	LABEL,WARNING/D	1	1- -632					
3A	8651 - 901 - 002 - 10	LABEL,WARNING/D	1	633-					
4	8651 - 902 - 001 - 00	LABEL,WARNING/E	1	1- -5					
4A	8651 - 902 - 001 - 10	LABEL,WARNING/E	1	6- -632					
4B	8651 - 902 - 001 - 20	LABEL,WARNING/E	1	633-					
5	8651 - 903 - 001 - 20	LABEL,WARNING/F	1	*					
6	8651 - 900 - 001 - 00	LABEL,WARNING/I	1	*					

NUMERICAL INDEX

ENGINE

PART CODE	FIG. KEY	PART CODE	FIG. KEY	PART CODE	FIG. KEY
5110-042-096-XX	1 1	5120-322-068-XX	3 10	5132-702-054-XX	4 4
5110-086-011-XX	1 2	5130-012-092-XX	2 1	5132-702-055-XX	1 9
5110-086-016-XX	1 2A	5130-012-130-XX	2 2	5140-242-294-9H	5 2
5110-086-026-XX	1 3	5130-022-070-XX	2 3	5140-372-104-9H	5 3
5110-092-024-XX	8 2	5130-022-078-XX	2 4	5140-432-064-XX	10 10
5110-092-175-XX	4 1	5130-086-001-XX	2 5	5150-032-090-XX	8 1
5110-092-346-XX	4 2	5130-086-002-XX	2 7	5150-032-164-XX	8 1A
5110-092-433-XX	1 4	5130-086-003-XX	2 8	5160-072-053-XX	3 12
5110-092-505-XX	9 1	5130-086-053-XX	2 6	5160-142-010-XX	8 5
5110-092-526-XX	10 9	5130-256-020-XX	2 9	5160-202-096-XX	8 6
5110-092-763-XX	10 2	5130-292-078-XX	2 10	5160-202-122-XX	8 6A
5110-092-764-XX	10 3	5130-292-079-XX	2 11	5160-252-137-XX	8 11
5110-092-769-XX	8 3	5130-292-106-XX	2 12	5160-302-067-XX	8 12
5110-092-943-XX	9 2	5130-426-008-XX	2 13	5160-312-066-XX	8 13
5110-092-944-XX	8 42	5130-426-010-XX	2 14	5160-352-056-XX	8 14
5110-092-945-XX	8 43	5130-812-085-XX	11 2	5160-352-058-XX	8 15
5110-092-946-XX	8 44	5130-912-068-XX	11 3	5160-380-24X-XX	8 16
5110-092-947-XX	1 5	5130-B05-08X-XX	7 10	5160-412-163-XX	8 17
5110-102-327-XX	9 3		10 21		8 18
5110-102-421-XX	9 3A	5130-B05-20X-XX	6 27A	5160-412-215-XX	8 18A
5110-112-227-XX	9 4	5130-B05-25X-XX	6 27	5160-606-001-XX	8 48
5110-122-189-XX	3 1	5130-B06-10X-XX	4 24	5160-732-098-XX	11 5
5110-122-223-XX	9 5		5 15	5160-736-001-XX	8 49
5110-122-251-9Y	9 9	5130-B06-14X-XX	1 30	5160-822-059-XX	4 5
5110-132-109-XX	9 6A		4 25	5161-262-113-XX	1 10
5110-132-110-XX	9 7	5130-B06-16X-XX	10 22	5161-262-151-XX	8 19
5110-132-140-XX	9 6	5130-B08-20X-XX	5 16	5161-422-053-XX	4 6
5110-132-141-XX	9 7A	5130-B08-30X-XX	4 26	5161-462-077-XX	11 6
5110-222-055-XX	1 6	5130-B08-35X-XX	11 21	5161-462-106-XX	11 7
5110-222-070-XX	1 7	5130-B08-40X-XX	4 27	5161-542-052-XX	4 7
5110-442-084-XX	5 1	5130-G06-12X-XX	5 17	5161-692-088-XX	7 14
5110-472-028-XX	2 2	5130-G06-14X-XX	5 18	5161-692-130-XX	7 15
5110-602-339-XX	8 45		10 23	5161-712-056-XX	7 16
5110-602-340-XX	8 46	5130-T08-45X-XX	1 31	5161-712-079-XX	7 17
5110-602-341-XX	8 47	5131-072-088-XX	2 16	5171-G08-18X-XX	1 32
5120-042-085-XX	3 2	5131-072-232-XX	2 17	5171-G08-20X-XX	1 33
5120-042-097-XX	3 2A	5131-162-056-XX	3 11	5172-G06-115-XX	8 53
5120-052-070-XX	3 3	5131-682-131-XX	11 4	5180-772-052-XX	9 10
5120-052-086-XX	3 3A	5131-692-360-XX	4 3	5180-B06-35X-XX	7 31
5120-092-058-XX	3 4	5131-692-436-XX	1 8	5210-392-059-XX	11 8
5120-092-060-XX	3 5	5131-832-252-XX	8 4	5210-402-052-XX	11 9
5120-112-052-XX	3 6	5132-516-019-XX	2 18	5210-661-020-XX	6 1
5120-162-054-XX	3 7	5132-516-020-XX	2 19	5210-802-054-XX	11 10
5120-162-055-XX	3 8	5132-516-039-XX	2 21	5211-182-077-XX	3 15
5120-202-058-XX	3 9	5132-516-041-XX	2 22	5211-182-083-XX	3 15A

ENGINE

PART CODE	FIG. KEY	PART CODE	FIG. KEY	PART CODE	FIG. KEY
5211-192-095-XX	6 2	5461-022-077-XX	2 23	5560-312-317-XX	12 4
5211-192-101-XX	6 2A	5461-026-007-XX	2 24	5560-382-504-XX	12 5
5211-212-008-XX	6 3	5461-F08-00X-XX	9 15	5560-402-285-XX	12 6
5211-212-070-XX	6 3A		11 20	5560-402-286-XX	12 7
5211-212-086-XX	6 4	5490-022-078-XX	1 11	5560-402-287-XX	12 8
5211-302-060-XX	6 5	5490-022-097-XX	1 35	5560-402-288-XX	12 9
5211-302-066-XX	6 6	5490-022-107-XX	1 11A	5560-402-289-XX	12 10
5211-632-073-XX	11 1	5490-156-028-XX	1 12	5560-402-290-XX	12 11
5211-692-004-XX	6 7	5490-156-174-XX	1 13	5560-402-291-XX	12 12
5211-872-055-XX	7 18	5490-402-066-XX	10 1	5590-312-086-XX	6 13
5211-882-001-XX	8 7	5490-552-059-XX	4 11	5590-412-087-XX	5 9
5211-882-004-XX	8 7A	5490-552-071-XX	4 10	5590-562-090-XX	4 13
5211-932-072-XX	6 8	5490-552-073-XX	4 11A	5590-562-101-XX	2 28
5211-932-126-XX	6 8A	5490-702-547-9Y	9 8	5590-662-431-9H	5 10
5211-932-154-XX	6 9	5490-782-061-XX	3 19	5590-662-564-9H	5 11
5214-B04-12X-XX	7 11	5490-782-068-XX	3 19A	5590-712-070-XX	4 14
5214-B04-14X-XX	8 41	5490-892-232-9H	5 4	5590-712-114-XX	4 15
5214-B04-20X-XX	7 12	5490-892-233-9H	5 5	5592-312-062-XX	4 16
5214-B04-25X-XX	7 13	5490-892-330-9H	5 6	5600-A10-00X-XX	4 29
5220-B06-08X-XX	4 28	5490-892-392-9H	5 7	5601-A63-07X-XX	1 34
5224-B04-08X-XX	5 19	5491-052-096-XX	10 16	5670-D20-11X-XX	4 30
	6 28	5491-102-067-XX	7 22	5670-D20-16X-XX	4 31
5224-B05-08X-XX	8 54	5491-132-098-XX	7 1	5702-A04-100-0X	8 56
5224-B06-16X-XX	5 20	5491-162-055-XX	10 6	5705-A06-100-0X	10 26
5224-B06-20X-XX	6 29	5491-182-077-XX	3 13	5920-022-269-XX	7 23
5260-112-104-XX	6 10	5491-182-099-XX	3 13A	5920-022-273-XX	1 16
5260-112-233-XX	8 50	5491-182-132-XX	3 14	5920-022-274-XX	9 12
5260-112-314-XX	6 11	5491-192-134-XX	2 26	5920-022-277-XX	11 15
5260-112-331-XX	6 12	5491-192-179-XX	2 27	5920-022-310-XX	1 17
5270-102-122-XX	11 11	5491-206-019-XX	1 14	5920-042-083-XX	1 18
5310-646-001-XX	4 8	5491-206-061-XX	1 14A	5920-042-094-XX	1 19
5311-B06-00X-XX	7 32	5491-206-106-XX	1 15	5920-092-004-XX	10 12
5315-B12-00X-XX	10 24	5491-212-106-XX	8 20	5920-092-025-XX	8 8
5317-B08-00X-XX	11 19	5491-212-152-XX	8 20A	5920-092-080-XX	8 22
5317-R08-00X-XX	9 14	5491-232-005-XX	8 21	5920-092-081-XX	8 23
5320-852-066-XX	11 12	5491-232-068-XX	8 21A	5920-092-166-XX	9 11
5320-852-097-XX	11 13	5510-232-130-XX	10 8	5920-092-182-XX	3 20
5390-032-073-XX	7 19	5510-362-068-XX	10 11	5920-092-212-XX	10 7
5391-292-011-XX	7 20	5520-052-070-XX	4 12	5920-092-244-XX	8 24
5410-B06-00X-XX	8 55	5520-052-105-XX	4 12A	5920-092-308-XX	1 20
5410-B12-00X-XX	10 25	5550-202-079-9H	5 8		6 14
5411-B06-00X-XX	7 33	5554-A06-00X-XX	7 34	5920-151-193-XX	2 29
5420-362-060-XX	7 21	5560-302-142-XX	12 1		8 57
5430-282-068-XX	10 4	5560-302-307-XX	12 2	5920-152-120-XX	7 3
5430-282-069-XX	10 5	5560-312-316-XX	12 3	5920-152-139-XX	3 21

PART CODE	FIG. KEY	PART CODE	FIG. KEY	PART CODE	FIG. KEY
5920-152-146-XX	11 16	5920-372-199-XX	4 17	5921-432-006-XX	7 26
5920-152-147-XX	11 17	5920-372-200-XX	4 18	5921-432-142-XX	8 35
5920-152-166-XX	1 21	5920-382-094-XX	2 53	5921-432-179-XX	5 13
5920-152-167-XX	6 15		6 19	5921-432-182-XX	5 14
5920-222-019-XX	7 24	5920-431-263-XX	1 23	5921-442-033-XX	7 28
5920-222-089-XX	7 25	5920-431-266-XX	1 24	5921-442-037-XX	8 36
5920-222-206-XX	1 22	5920-432-006-XX	8 28	5921-442-043-XX	10 15
5920-222-218-XX	11 18	5920-432-113-XX	3 16	5921-442-166-XX	8 37
5920-222-220-XX	9 13	5920-492-054-XX	3 22A	5921-442-174-XX	8 10
5920-222-229-XX	6 16	5920-492-096-XX	1 25	5921-442-220-XX	7 6
5920-225-53X-XX	10 17	5920-492-097-XX	1 26	5921-442-266-XX	7 7
5920-252-003-XX	5 12	5920-492-100-XX	3 22	5921-442-281-XX	7 8
5920-252-210-XX	2 30	5920-492-104-XX	1 27	5921-442-323-XX	3 18
5920-252-211-XX	2 31	5920-492-223-XX	3 23	5921-502-121-XX	8 38
5920-252-212-XX	2 32	5920-492-227-XX	1 28	5921-502-182-XX	7 9
5920-252-213-XX	2 33	5920-551-299-XX	10 13	5921-502-193-XX	2 20
5920-252-214-XX	2 34	5920-552-072-XX	2 54	5921-502-218-XX	8 38A
5920-252-215-XX	2 35	5920-552-073-XX	4 19	5921-702-023-XX	8 39
5920-252-216-XX	2 36	5920-552-083-XX	10 14	5921-702-043-XX	10 19
5920-252-217-XX	2 37	5920-552-148-XX	8 29	5921-702-088-XX	10 20
5920-252-218-XX	2 38	5920-592-012-XX	6 20	5921-902-011-XX	8 40
5920-252-219-XX	2 39	5920-592-169-XX	10 18	5921-902-066-XX	8 52A
5920-252-220-XX	2 40	5920-592-226-XX	8 52	5921-902-167-XX	6 25
5920-252-221-XX	2 41	5920-632-149-XX	8 30		6 26
5920-252-222-XX	2 42	5920-632-197-XX	8 30A	5922-002-029-XX	7 28
5920-252-223-XX	2 43	5920-642-062-XX	8 31	5922-002-035-XX	4 23
5920-252-224-XX	2 44	5920-642-079-XX	8 31A	5922-002-036-XX	7 29
5920-252-225-XX	2 45	5920-650-78X-XX	8 9	5922-002-070-XX	7 30
5920-252-226-XX	2 46	5920-662-092-XX	4 20		
5920-252-227-XX	2 47	5920-662-207-XX	4 21		
5920-252-228-XX	2 48	5920-662-211-XX	4 9		
5920-262-156-XX	2 49	5920-702-075-XX	6 21		
5920-262-160-XX	2 50	5920-702-077-XX	6 22		
5920-272-003-XX	8 25	5920-712-099-XX	6 23		
5920-272-025-XX	8 26	5920-712-112-XX	6 24		
5920-332-067-XX	8 27	5920-812-009-XX	8 32		
5920-332-080-XX	2 51	5920-812-033-XX	3 17		
5920-332-081-XX	11 14	5920-812-305-XX	4 22		
5920-360-08X-XX	2 52	5920-812-316-XX	7 5		
5920-360-23X-XX	1 36	5920-932-002-XX	8 33		
5920-372-012-XX	8 51	5920-932-069-XX	8 34		
5920-372-020-XX	7 4	5921-102-093-XX	13 1		
5920-372-063-XX	6 17	5921-412-108-XX	2 25		
5920-372-176-XX	10 27	5921-412-112-XX	2 15		
5920-372-177-XX	6 18	5921-432-005-XX	1 29		

NUMERICAL INDEX

2502-098-100-00

PART CODE	FIG. KEY	PART CODE	FIG. KEY	PART CODE	FIG. KEY
1323-220-012-00	7 7	1593-112-200-00	2 1	2111-101-011-00	6 4
1325-401-009-00	4 31	1593-112-222-00	2 7A	2111-441-027-10	7 13
1342-402-006-00	25 17	1593-117-003-10	3 7	2130-407-003-00	20 15
1365-224-002-00	10 15	1593-304-008-00	6 25	2130-525-001-10	24 13
	10 19	1593-310-054-20	7 8	2130-601-006-20	7 11
1373-121-001-00	23 15	1593-310-520-20	7 3	2500-623-220-00	17 12
1376-606-005-00	16 9	1593-310-540-00	7 6	2500-901-008-00	18 8
1383-301-002-00	4 4	1593-332-052-10	13 14	2500-901-014-30	22 3
1386-241-002-00	8 4	1593-403-001-10	10 22	2500-901-027-00	26 2
	12 4	1593-403-005-00	10 30		18 9
1386-624-292-00	17 16	1593-406-005-10	11 5	2500-930-001-00	19 32
1386-624-293-00	17 17	1593-406-006-00	11 9	2502-101-003-00	19 38
1386-624-300-00	17 20	1593-406-240-10	11 8	2502-101-003-00	1 4
1386-624-330-00	17 15	1593-406-250-00	11 4	2502-101-210-30	1 3
1414-606-002-00	15 15	1593-601-073-00	15 24	2502-101-220-10	1 7
1415-120-006-00	5 6	1593-611-011-10	16 13	2502-101-230-00	1 10
	7 25	1593-611-011-20	16 13A	2502-101-240-00	1 13
1415-125-021-00	13 3	1593-611-014-00	16 8	2502-105-001-10	1 15
1425-621-004-00	13 13	1593-612-220-10	1 19	2502-105-002-00	1 23
	17 22	1593-612-230-00	1 22	2502-105-003-00	1 16
1426-621-038-00	3 11	1593-622-001-10	17 6	2502-105-004-10	1 25
1427-130-260-00	21 14	1593-622-211-10	17 8	2502-105-005-10	1 26
1427-317-003-00	21 4	1593-622-240-00	17 2	2502-105-006-00	1 27
	21 18	1593-622-250-00	17 1	2502-112-001-20	2 4
	21 21	1593-622-270-00	17 4	2502-112-210-10	2 10
1427-621-002-10	2 2	1593-623-270-00	16 14	2502-117-001-20	3 5
1427-621-012-00	15 25	1593-623-270-10	16 14A	2502-117-001-30	3 5A
	16 4	1593-623-272-00	16 15	2502-117-200-20	3 1
1444-601-011-00	15 16	1593-623-273-00	16 16	2502-117-210-30	3 4
1444-601-015-00	17 9	1593-623-520-00	17 25	2502-201-001-10	4 33
1518-122-002-00	7 23	1593-623-530-00	17 13	2502-201-003-20	4 1
1527-604-002-00	15 20	1593-901-015-00	18 10	2502-201-004-10	4 2
1560-285-006-20	21 23		19 33	2502-201-005-10	4 34
1560-664-250-00	17 29	1600-112-231-00	2 7	2502-201-006-20	4 38
1560-664-252-00	17 30		2 11	2502-201-006-30	4 38A
1560-664-253-00	17 31	1600-112-232-00	2 8	2502-201-007-20	4 30
1564-512-001-00	11 2		2 12	2502-201-014-00	4 26A
1564-654-213-00	17 3	1600-505-007-00	3 10	2502-201-015-00	4 27
1575-623-010-00	17 11	1608-901-004-00	18 6	2502-201-200-00	4 9
1581-740-116-00	1 6	1614-680-250-00	17 29A	2502-201-210-40	4 5
	1 8	1636-901-015-00	18 12	2502-201-220-40	4 22
	1 11	1640-903-016-00	19 21	2502-201-220-50	4 22A
	15 23	1640-903-036-00	19 7	2502-201-260-00	4 11
1593-112-003-20	2 6	1640-904-016-00	19 14	2502-201-260-10	4 11A
1593-112-051-30	2 3	1640-905-016-00	19 28	2502-201-270-00	4 20

PART CODE	FIG. KEY	PART CODE	FIG. KEY	PART CODE	FIG. KEY
2502-205-001-10	4 42	2502-401-200-40	9 1	2502-554-006-20	14 28
2502-205-003-10	4 44	2502-401-200-50	9 1A	2502-554-007-00	14 22
2502-205-004-00	4 46	2502-401-200-60	9 1B	2502-554-008-10	14 18
2502-205-005-00	4 48	2502-401-200-70	9 1C	2502-554-210-40	14 16
2502-205-200-00	4 39	2502-402-001-20	10 2	2502-601-001-20	15 2
2502-221-001-10	5 7	2502-402-005-30	10 1	2502-601-002-00	15 5
2502-221-002-20	5 17	2502-402-005-40	10 1A	2502-601-003-00	15 6
2502-221-003-00	5 9	2502-403-001-20	10 20	2502-601-004-10	15 12
2502-221-200-00	5 15	2502-403-002-20	10 21	2502-601-005-00	15 7
2502-221-210-20	5 1	2502-403-003-20	10 29	2502-601-006-00	15 4
2502-221-220-20	5 4	2502-403-004-10	10 11	2502-601-210-40	15 1
2502-221-236-00	5 16	2502-403-005-00	10 23	2502-601-220-30	15 10
	7 19	2502-403-006-00	10 13	2502-606-001-00	16 5
2502-221-250-10	5 12	2502-403-007-00	10 17	2502-606-002-00	16 2
2502-301-001-30	6 1	2502-403-210-40	10 10	2502-606-003-10	16 1
2502-301-002-30	6 6	2502-403-220-30	10 16	2502-606-220-10	16 6
2502-301-003-20	6 3	2502-406-001-10	11 6	2502-611-001-00	16 19
2502-302-001-30	6 13	2502-406-200-20	11 1	2502-611-210-00	16 12
2502-302-002-20	6 14	2502-407-001-10	11 18	2502-611-210-10	16 12A
2502-303-210-10	6 18	2502-407-200-20	11 17	2502-616-001-40	15 14
2502-304-001-20	6 24	2502-407-210-30	11 13	2502-616-002-20	15 19
2502-304-002-20	6 20	2502-411-001-00	12 6	2502-616-004-00	15 17
2502-304-003-20	6 21	2502-411-201-00	12 1	2502-621-001-00	15 21
2502-304-004-30	6 22	2502-411-210-00	12 2	2502-623-200-30	17 10
2502-304-005-20	6 23	2502-411-210-10	12 2A	2502-623-200-40	17 10A
2502-307-001-40	6 28	2502-532-001-10	13 2	2502-623-202-00	17 14
2502-307-002-40	6 33	2502-532-002-10	4 26	2502-901-001-20	18 1
2502-307-003-00	6 29		13 6	2502-901-002-30	18 2
	6 34	2502-532-200-20	13 10	2502-901-003-00	18 3
2502-307-004-00	6 30	2502-532-200-30	13 10A	2502-901-003-10	18 3A
2502-307-210-00	6 31	2502-532-220-40	13 8	2502-901-004-10	18 4
2502-310-001-20	7 9	2502-532-230-20	13 1	2502-901-004-20	18 4A
2502-310-002-20	7 12	2502-532-230-30	13 1A	2502-901-006-10	18 5
2502-310-003-20	7 14	2502-533-002-10	13 17	2502-901-007-00	18 7
2502-310-200-10	7 18	2502-533-230-00	13 15	2502-901-008-00	18 11
2502-310-240-10	7 1	2502-553-001-20	14 2		19 34
2502-311-210-30	7 23	2502-553-002-10	14 9	2502-905-001-00	19 1
2502-317-002-00	8 9	2502-553-003-10	14 5	2502-905-001-10	19 1A
	12 10	2502-553-004-00	14 12	2502-905-002-00	19 2
2502-317-003-00	8 6	2502-553-210-30	14 1	2502-905-003-00	19 3
2502-317-201-00	8 1	2502-553-210-40	14 1A	2502-905-004-00	19 4
2502-317-210-00	8 2	2502-554-001-10	14 23	2502-905-005-00	19 5
2502-317-210-10	8 2A	2502-554-003-10	14 20	2502-905-006-00	19 4A
2502-401-002-20	9 3	2502-554-004-10	14 21	2502-905-021-00	19 6
2502-401-003-10	9 2	2502-554-005-20	14 24		19 35

2502-098-100-00

PART CODE	FIG. KEY	PART CODE	FIG. KEY	PART CODE	FIG. KEY
2502-905-200-00	19 29	3652-261-202-00	2 13	8595-901-005-00	22 4A
2502-906-001-10	19 8	3656-271-290-10	25 18		22 7A
2502-906-001-20	19 8A	3656-565-006-00	13 3A		22 10A
2502-906-002-00	19 9	3659-170-003-00	10 12		22 12A
2502-906-003-20	19 10		11 15	8595-901-006-00	22 2
2502-906-004-00	19 11		11 19	8595-901-007-00	18 13
2502-906-005-00	19 12		12 7	8595-902-001-10	22 6
2502-906-006-00	19 11A	3737-172-010-00	17 7	8595-902-002-00	22 7
2502-906-021-00	19 13	3737-233-006-00	4 17A	8595-903-001-00	22 9
	19 36	3737-341-006-00	20 10	8595-903-002-00	22 10
2502-906-200-00	19 30	3737-341-007-00	4 17	8650-101-001-10	20 5
2502-907-001-00	19 15		20 11	8650-101-002-00	20 1
2502-907-001-10	19 15A	3741-141-005-00	1 24	8650-201-001-10	20 2
2502-907-002-00	19 16	3746-172-013-00	17 21	8650-201-002-00	20 3
2502-907-003-00	19 17	3750-242-008-00	14 6	8650-203-001-10	4 10
2502-907-004-00	19 18	3754-371-011-00	4 25		20 7
2502-907-005-00	19 19	3761-212-004-00	23 4	8650-203-200-10	20 6
2502-907-006-00	19 18A	3768-112-001-00	21 10	8650-203-200-20	20 6A
2502-907-021-00	19 20	3768-172-008-00	17 24	8650-204-210-10	20 13
	19 37	4106-105-303-00	3 6	8650-301-210-20	20 23
2502-907-200-00	19 31		13 16	8650-302-001-00	20 24
2502-910-001-00	19 22	4131-206-015-00	4 14	8650-401-001-10	21 3
2502-910-001-10	19 22A	4334-155-003-00	1 5	8650-401-210-30	21 1
2502-910-002-00	19 23	7955-201-026-00	6 9	8650-401-210-40	21 1A
2502-910-003-00	19 24	8593-014-200-10	20 8	8650-401-250-00	21 2
2502-910-004-00	19 25	8595-301-001-70	20 16	8650-402-210-10	21 6
2502-910-005-00	19 26	8595-301-001-80	20 16A	8650-402-210-20	21 6A
2502-910-006-00	19 25A	8595-301-004-30	20 18	8650-402-220-00	21 8
2502-910-021-00	19 27	8595-301-005-30	20 25	8650-403-001-10	21 11
2706-501-003-00	1 28	8595-301-008-00	20 17	8650-403-210-10	21 12
2706-501-004-00	1 21	8595-301-008-10	20 17A	8650-502-210-00	21 19
2710-206-025-00	14 13	8595-301-500-50	20 22	8650-901-002-00	22 5
3560-201-015-00	15 16A	8595-305-011-00	20 26	8650-902-001-00	22 8
3567-402-004-00	23 12	8595-305-012-00	20 27	8650-903-001-00	22 11
3600-201-013-00	7 24	8595-405-500-20	21 5	8650-910-001-00	22 13
3610-631-002-00	15 8	8595-501-001-10	21 16	8650-910-002-00	22 12
3614-125-001-00	4 7	8595-501-004-00	21 22	8651-101-200-00	23 1
	4 12	8595-501-005-00	21 24	8651-101-200-10	23 1A
3614-820-004-00	24 17	8595-501-005-10	21 24A	8651-101-210-10	23 2
3615-820-003-00	23 19	8595-501-005-20	21 24B	8651-102-001-00	23 16
3615-820-240-10	25 13	8595-505-002-00	21 20	8651-102-201-00	23 8
3621-702-003-00	10 3	8595-505-051-00	21 17	8651-102-202-00	23 9
3631-270-003-00	17 5	8595-505-051-10	21 17A	8651-102-203-00	23 10
3640-703-001-00	4 16	8595-505-051-20	21 17B	8651-103-210-00	20 24A
	4 31A	8595-901-003-00	22 4		23 20

PART CODE	FIG. KEY	PART CODE	FIG. KEY	PART CODE	FIG. KEY
8651-201-210-10	23 17	V210-360-601-60	4 43		20 20
8651-202-001-00	24 4		23 3	V304-260-010-00	3 8
8651-202-201-00	24 2		24 5		5 8
8651-202-202-00	24 3		25 12		10 9
8651-202-210-10	24 1		25 14		11 21
8651-203-210-20	24 7		25 19		14 27
8651-203-220-00	24 8	V210-360-602-00	1 9	V304-260-012-00	14 7
8651-203-230-00	24 12		1 12	V304-260-014-00	23 5
8651-203-240-00	24 16	V210-360-603-00	17 32	V304-460-010-00	10 14
8651-203-250-00	24 9	V211-260-801-20	15 9	V304-460-014-00	20 28
8651-204-201-00	24 18		21 15	V327-262-214-00	8 7
8651-204-210-00	24 19	V211-260-801-60	2 9	V328-262-110-00	10 25
8651-204-220-00	24 20		7 2		11 10
8651-301-200-20	25 1		15 13		11 14
8651-301-200-30	25 1A	V211-260-802-00	20 14		12 8
8651-301-202-00	25 3	V211-260-802-50	1 1	V328-262-112-00	10 4
	25 9		6 32		10 32
8651-301-203-00	25 6	V211-260-803-00	6 5	V334-260-010-00	10 24
8651-301-210-10	25 2	V211-360-801-20	17 23	V335-260-012-00	10 31
8651-301-211-10	25 5	V211-360-801-60	4 21	V360-260-006-00	15 3
8651-301-230-00	25 2A		4 47		16 3
8651-302-200-00	25 7		9 4	V361-260-006-00	23 13
8651-302-210-10	25 8		11 3		24 6
8651-601-200-10	25 11	V211-360-802-00	1 2		25 15
8651-601-210-00	25 16		1 14	V362-260-008-00	16 20
8651-901-002-00	26 3	V211-360-804-00	4 40	V363-260-008-00	4 6
8651-901-002-10	26 3A	V211-360-811-00	4 41		4 19
8651-902-001-00	26 4	V211-361-002-50	23 18		7 10
8651-902-001-10	26 4A	V211-560-802-00	6 12		11 7
8651-902-001-20	26 4B		23 14		16 7
8651-903-001-20	26 5	V211-560-802-50	14 17		21 7
8651-910-001-00	26 6		14 19		21 9
J061-210-012-00	1 24A	V211-561-003-00	4 3		21 13
J910-000-200-00	18 5A	V273-360-802-50	13 9		21 18A
	22 1	V301-260-006-00	2 5		25 4
	26 1		16 18		25 10
V111-163-001-60	17 26	V304-260-008-00	2 15	V363-260-010-00	21 25A
V111-164-000-60	17 18		4 18	V401-160-003-00	17 27
V120-266-001-60	15 22		4 32	V401-160-004-00	17 19
V200-260-601-60	23 11		5 5	V401-160-006-00	4 37
V200-360-601-60	4 36		7 17		16 17
V201-260-801-60	6 10		13 20	V401-160-008-00	2 14
V201-260-802-50	15 18		14 15		16 11
V201-260-804-50	13 18		16 10		20 21
V210-260-601-60	15 11		20 12	V401-160-010-00	10 27

2502-098-100-00

PART CODE	FIG. KEY	PART CODE	FIG. KEY	PART CODE	FIG. KEY
V401-160-012-00	11 20 10 34 14 8		5 18 10 5 10 35		
V401-160-014-00	20 29 23 6	V500-163-003-00	13 5 7 21		
V411-260-003-00	17 28		8 8		
V411-260-006-00	3 2		21 25		
V411-260-008-00	1 17 5 10 5 13	V580-140-302-00 V580-140-402-00 V580-140-602-50	4 45 24 21 5 2		
	7 15 13 11 13 19 14 10 14 14	V580-140-604-50 V590-131-210-00 V600-110-600-40 V600-110-600-50 V600-110-620-40	4 23 5 3 6 15 6 16 6 19		
V411-260-010-00	3 9 10 26 11 11	V600-110-620-50 V600-110-620-60 V600-150-600-40	6 35 6 27 12 5		
V411-260-012-00	7 4 10 33	V704-140-012-00	4 8 4 13		
	14 3 14 25 24 11 24 15	V704-140-015-00 V704-140-013-00 V704-140-020-00	7 5 4 29 13 7 20 9 4 15		
V411-260-014-00	4 24				
	8 5 13 4 23 7	V705-140-035-00 V705-140-040-00 V706-140-080-00	10 18 20 4 4 28 20 19 6 26		
V411-260-018-00	7 26				
V500-162-501-50	3 3				
V500-162-502-00	10 28 11 12 11 16	V720-101-900-80 V721-103-104-50 V744-120-350-70 V744-125-400-80	6 11 6 17 6 8 6 2 6 7		
V500-162-502-50	12 9 14 4				
	14 11 14 26 5 11 5 14 7 16	V760-150-000-00 V762-150-000-00 V999-200-003-00 W201-361-006-00	10 6 10 7 8 3 12 3 10 8		
V500-163-001-50					
	13 12 1 18 24 10 24 14				
V500-163-002-00					
V500-163-002-50	4 25				

ALPHABETICAL INDEX

ENGINE

DESCRIPTION	FIG. KEY	DESCRIPTION	FIG. KEY
ARM-ASSY	7 18	COLLET	3 6
ARM-PIVOT	7 19	COVER	5 2
ARM-ROCKER	3 7	COVER-CRANKCASE	1 12
ARM-ROCKER	3 8	COVER-CRANKCASE	1 13
ARMATURE	11 10	CAMSHAFT-COMP	3 13
ARRESTER-SPARK	9 10	CAMSHAFT-COMP	3 13A
BOLT	1 16	CAMSHAFT-COMP	3 14
BOLT	1 17	CAP, AIR FILTER	9 5
BOLT	2 20	CAP, SPARK ARRESTER	9 9
BOLT-FLANGED	10 21	CAP, VALVE	3 1
BOLT-FLANGED	1 30	CAP-SPARK PLUG	6 5
BOLT-FLANGED	1 31	CAP-SPARK PLUG	6 6
BOLT-STUD	1 32	CARBURETOR-ASSY	8 1
BOLT-STUD	1 33	CARBURETOR-ASSY	8 1A
BALL-STEEL	4 29	CASE-AIR FILTER	9 4
BEARING-BALL	1 34	CASE-ROCKER	1 6
BEARING-PLANE	2 25	CASE-ROCKER	1 7
BEARING-PLANE	2 15	CHAMBER-FLOAT	8 6
BOLT	7 23	CHAMBER-FLOAT	8 6A
BOLT	9 12	CLAMP	8 51
BOLT	11 15	CLAMP	7 4
BOLT	8 38	CLAMP	6 17
BOLT	8 38A	CLAMP	10 27
BOLT, 5X18	7 9	CLAMP	6 18
BOLT-FLANGED	7 10	CLAMP	4 17
BOLT-FLANGED	6 27A	CLAMP	4 18
BOLT-FLANGED	6 27	CLAMP	8 39
BOLT-FLANGED	4 24	CLAMP	10 19
BOLT-FLANGED	5 15	CLAMP	10 20
BOLT-FLANGED	4 25	CLUTCH-ASSY	11 2
BOLT-FLANGED	10 22	COIL-CHARGING	6 13
BOLT-FLANGED	5 16	COIL-IGNITION	6 3
BOLT-FLANGED	4 26	COIL-IGNITION	6 3A
BOLT-FLANGED	11 21	COIL-IGNITION	6 4
BOLT-FLANGED	4 27	COLLAR	8 25
BOLT-FLANGED	5 17	COLLAR	8 26
BOLT-FLANGED	5 18	COLLAR	7 26
BOLT-FLANGED	10 23	COLLAR	8 35
BOLT-STUD	8 53	COLLAR	5 13
BOLT-UPSET-WS	7 31	COLLAR, 6. 2X7. 8X5	5 14
BRACKET	5 1	COVER-ASSY	11 6
BRACKET	7 2	COVER-ASSY	11 7
BRACKET-TAP	10 16	COVER-PUMP	4 6
BRUSH	11 8	CRANKCASE-COMP	1 14
COLLAR	1 29	CRANKCASE-COMP	1 14A

ENGINE

DESCRIPTION	FIG. KEY	DESCRIPTION	FIG. KEY
CRANKCASE-COMP	1 15	GEAR-HELICAL	2 28
CRANKSHAFT-ASSY	2 26	GEAR-HERICAL	4 13
CRANKSHAFT-ASSY	2 27	GOVERNOR-ASSY	7 22
CUP, FUEL TAP	10 11	GROMMET	6 23
DECOMPRESSOR	3 15	GROMMET	6 24
DECOMPRESSOR	3 15A	GUARD	5 8
DIAPHRAGM	10 4	GUIDE, VALVE IN	1 35
DIAPHRAGM	10 5	GUIDE-VALV EX	1 11
ELEMENT-AIR FILTER	9 6A	GUIDE-VALVE	1 11A
ELEMENT-AIR FILTER	9 7	HAUSING-FAN	5 11
ELEMENT-AIR FILTER	9 6	HEAD-COMP-CYLINDER	1 2
ELEMENT-AIR FILTER	9 7A	HEAD-COMP-CYLINDER	1 2A
FAN	5 9	HEAD-COMP-CYLINDER	1 3
FILLER	4 16	HOLDER, BRUSH	11 3
FILTER, FUEL TAP	10 10	HOLDER-MAIN JET	8 21
FILTER-ASSY-AIR	9 3	HOLDER-MAIN JET	8 21A
FILTER-ASSY-AIR	9 3A	HOUSING-FAN	5 10
FILTER-OIL	4 11	IGNITER	6 2
FILTER-OIL	4 10	IGNITER	6 2A
FILTER-OIL	4 11A	INSULATOR	11 5
FLOAT	8 13	INSULATOR	8 49
FLYWHEEL-ASSY	6 8	JET-AIR 1.1	8 15
FLYWHEEL-ASSY	6 8A	JET-AIR 1.8	8 14
FLYWHEEL-ASSY	6 9	JET-MAIN 97.5	8 30
GASKET	8 2	JET-MAIN 97.5	8 30A
GASKET	4 1	JET-PILOT 60	8 31
GASKET	10 9	JET-PILOT 60	8 31A
GASKET	8 3	JOINT	4 14
GASKET	8 16	JOINT	4 15
GASKET , MUFFLER	9 2	KEY	2 53
GASKET, OIL GAUGE	4 2	KEY	6 19
GASKET, AIR FILTER	9 1	LABEL	12 1
GASKET, CARBURETOR	8 42	LABEL (139597)	12 2
GASKET, CARBURETOR	8 45	LABEL-BRAND	12 5
GASKET, FUEL PUMP	10 2	LABEL-MANUAL (139597)	12 3
GASKET, FUEL PUMP	10 3	LABEL-MANUAL (139597)	12 4
GASKET, INSULATOR	8 43	LABEL-WARNING, D	12 8
GASKET, INSULATOR	8 46	LABEL-WARNING, E	12 10
GASKET, INTAKE PIPE	8 44	LABEL-WARNING, F	12 7
GASKET, INTAKE PIPE	8 47	LABEL-WARNING, GB	12 6
GASKET-CRANKCASE	1 5	LABEL-WARNING, I	12 9
GASKET-HEAD	1 1	LABEL-WARNING, NL	12 11
GASKET-ROCKER CASE	1 4	LABEL-WARNING, S	12 12
GAUGE	4 12	LEVER, SHIFT	11 4
GAUGE	4 12A	LINK, GOVERNOR	7 16

DESCRIPTION	FIG. KEY	DESCRIPTION	FIG. KEY
LINK, GOVERNOR	7 17	PLUG-SPARK, RN11YC	6 21
LINK-CHOKE	7 14	PUMP-ASSY-OIL	4 5
LINK-CHOKE	7 15	PUMP-FUEL	10 1
MUFFLER-COMP	9 8	ROD	2 23
NOZZLE-MAIN 65A	8 20	ROD	2 24
NOZZLE-MAIN 65A	8 20A	ROD-ASSY-CONNECTING	2 18
NUT	2 29	ROD-ASSY-CONNECTING	2 19
NUT	8 57	ROD-ASSY-CONNECTING	2 21
NUT	7 3	ROD-ASSY-CONNECTING	2 22
NUT	3 21	REGULATOR-VOLTAGE	6 1
NUT	11 16	RETAINER-VALVE	3 4
NUT	11 17	RETAINER-VALVE	3 5
NUT	1 21	RING, SNAP	1 36
NUT	6 15	RING-O	2 54
NUT-HEX	7 32	RING-O	10 13
NUT-HEX-FINE	10 24	RING-O	4 19
NUT-HEX-SMALL	11 19	RING-O	10 14
NUT-HEX-SMALL	9 14	RING-SET-PISTON	2 5
O RING	4 30	RING-SET-PISTON	2 6
O RING	4 31	RING-SET-PISTONL	2 7
O RING	8 29	RING-SET-PISTONL	2 8
PANEL-COMP-CONTROL	7 1	RING-SET-PISTONL	2 9
PIN	1 23	RING-SNAP	8 27
PIN	1 24	RING-SNAP	2 51
PIN	8 28	RING-SNAP	11 14
PIN	3 16	RING-SNAP	2 52
PIN-PISTON	2 3	ROD-PUSH	3 11
PIN-PISTON	2 4	ROTOR-PUMP	4 7
PIN-SNAP	7 34	SCREEN	5 3
PIPE-COMP	4 8	SCREW	10 12
PIPE-INTAKE	8 48	SCREW	8 8
PISTON-ENGINE	2 1	SCREW	8 22
PISTON-ENGINE	2 2	SCREW	8 23
PISTON-ENGINE-L-0.25	2 10	SCREW	3 20
PISTON-ENGINE-L-0.50	2 11	SCREW	10 7
PISTON-ENGINE-L-0.50	2 12	SCREW	8 24
PLATE	4 3	SCREW	1 20
PLATE	1 8	SCREW	6 14
PLATE	8 4	SCREW, 5X8	9 11
PLATE	4 4	SCREW-PAN	7 11
PLATE	1 9	SCREW-PAN	8 41
PLUG	4 21	SCREW-PAN	7 12
PLUG	4 9	SCREW-PAN	7 13
PLUG, DRAIN	4 20	SCREW-PAN-CROS	4 28
PLUG-SPARK, BPR5ES	6 22	SCREW-PAN-WP-CROS	5 19

ENGINE

DESCRIPTION	FIG. KEY	DESCRIPTION	FIG. KEY
SCREW-PAN-WP-CROS	6 28	SLEEVE	7 21
SCREW-PAN-WP-CROS	8 54	SOLENOID, CARBURETOR	8 7
SCREW-PAN-WP-CROS	5 20	SOLENOID, CARBURETOR	8 7A
SCREW-PAN-WP-CROS	6 29	SPACER	2 49
SCREW-PILOT AIR	8 5	SPACER	2 50
SEAL	8 33	SPRING	8 32
SEAL	8 34	SPRING	3 17
SEAL-OIL	1 25	SPRING	4 22
SEAL-OIL	1 26	SPRING	7 5
SEAL-OIL	1 27	SPRING	7 28
SEAL-OIL	1 28	SPRING	8 36
SEAL-OIL	3 22A	SPRING	10 15
SEAL-OIL	3 22	SPRING	8 37
SEAL-OIL	3 23	SPRING	8 10
SEAT-SPRING	3 12	SPRING	7 6
SHAFT	2 16	SPRING	7 7
SHAFT	2 17	SPRING	7 8
SHAFT-CARBURETOR	8 17	SPRING	3 18
SHAFT-CARBURETOR	8 18	SPRING BRUSH	11 9
SHAFT-CARBURETOR	8 18A	SPRING-ENGINE VALVE	3 19
SHAFT-ROCKER	3 9	SPRING-ENGINE VALVE	3 19A
SHIM, 1. 18	2 30	SPRING-GOVERNOR	7 20
SHIM, T=1. 20	5 12	STARTER-ELECTRIC	11 1
SHIM, T=1. 215	2 31	STOPPER	11 12
SHIM, T=1. 25	2 32	STOPPER	11 13
SHIM, T=1. 285	2 33	STUD	1 19
SHIM, T=1. 32	2 34	STUD-6X14	1 18
SHIM, T=1. 355	2 35	SWITCH	11 11
SHIM, T=1. 39	2 36	TAP-ASSY	10 8
SHIM, T=1. 425	2 37	TAPPET	3 10
SHIM, T=1. 46	2 38	TERMINAL	6 7
SHIM, T=1. 495	2 39	TOOL-WRENCH, 19X21	13 1
SHIM, T=1. 53	2 40	TUBE	10 18
SHIM, T=1. 565	2 41	TUBE	6 25
SHIM, T=1. 60	2 42	TUBE	6 26
SHIM, T=1. 635	2 43	TUBE, 11. 6X16X116	8 52
SHIM, T=1. 67	2 44	TUBE, 11. 6X16X116	8 52A
SHIM, T=1. 705	2 45	TUBE, 4. 5X6. 5X100	8 40
SHIM, T=1. 74	2 46	TUBE, 5X6X55	6 20
SHIM, T=1. 775	2 47	TUBE-BRAID	10 26
SHIM, T=1. 81	2 48	TUBE-RUBBER	8 56
SHROUD-ENGINE	5 7	VALVE	1 10
SHROUD-ENGINE	5 4	VALVE, CHOKE	8 19
SHROUD-ENGINE	5 5	VALVE-ASSY	10 6
SHROUD-ENGINE	5 6	VALVE-EXHAUST	3 3

DESCRIPTION	FIG. KEY	DESCRIPTION	FIG. KEY
VALVE-EXHAUST	3 3A		
VALVE-FLOAT	8 12		
VALVE-INTAKE	3 2		
VALVE-INTAKE	3 2A		
VALVE-THROTTLE 90	8 11		
W-PLAIN-S	8 55		
W-PLAIN-S	10 25		
WASHER	7 25		
WASHER	11 18		
WASHER	9 13		
WASHER	6 16		
WASHER	10 17		
WASHER	8 9		
WASHER	4 23		
WASHER	7 29		
WASHER	7 30		
WASHER (148906)	7 24		
WASHER, 6.5X11.5X2.0	7 28		
WASHER-10X20X2	1 22		
WASHER-PLAIN	7 33		
WASHER-SPRING	9 15		
WASHER-SPRING	11 20		
WEIGHT	2 13		
WEIGHT	2 14		
WIRE-LEAD	6 10		
WIRE-LEAD	8 50		
WIRE-LEAD (B52571)	6 11		
WIRE-LEAD, L=260	6 12		

ALPHABETICAL INDEX

CHASSIS

DESCRIPTION	FIG. KEY	DESCRIPTION	FIG. KEY
ADJUSTER, ROD	7 12	BOLT(SP)/M6X16	4 43
ARM, BRAKE	7 9	BOLT(SP)/M6X16	23 3
ARM, HOOD	15 12	BOLT(SP)/M6X16	24 5
ARM, KNUCKLE/LH COMP	10 10	BOLT(SP)/M6X16	25 12
ARM, KNUCKLE/RH COMP	10 16	BOLT(SP)/M6X16	25 14
ARM, PIT MAN	10 11	BOLT(SP)/M6X16	25 19
ARM, PTC TENSION ASSY	13 1	BOLT, BATTERY	2 4
ARM, PTC TENSION ASSY	13 1A	BOLT, SEMS	6 5
ARM, TENSION ASSY	20 6	BOLT, SEMS	17 23
ARM, TENSION ASSY	20 6A	BOLT, SEMS (S)	15 11
ARM, TENSION/F COMP	4 5	BOLT, SEMS (SP)	4 21
ARM, TENSION/HST COMP	4 22	BOLT, SEMS (SP)	4 47
ARM, TENSION/HST COMP	4 22A	BOLT, SEMS (SP)	9 4
ARM/TENSION/F	4 9	BOLT, SEMS (SP)	11 3
AXLE, FRONT	10 1	BOLT, SEMS (S)	20 14
AXLE, FRONT	10 1A	BOLT, SEMS (S) M8X12	15 9
BAG, COLLECTOR COMP	24 20	BOLT, SEMS (S) M8X12	21 15
BAND, HARNESS	17 7	BOLT, SEMS (S) M8X16	2 9
BAND, HARNESS	17 21	BOLT, SEMS (S) M8X16	7 2
BAND, HOSE ASSY/12	1 24	BOLT, SEMS (S) M8X16	15 13
BAND, SHUTER ASSY	25 2A	BOLT, SEMS/M8X25 7T	14 17
BAND, WIRE/250	25 17	BOLT, SEMS/M8X25 7T	14 19
BATTERY,	2 1	BOLT, SP	17 32
BEARING RB	4 27	BOLT, SP/M8X110	4 41
BEARING, BALL UNIT	6 31	BOLT, SP/M8X40	4 40
BEARING, RB	20 17	BOLT, WING SP/M8X25	13 9
BEARING, RB	20 17A	BOLT/M 6X16	23 11
BEARING, RB	20 3	BOLT/M 8X16	6 10
BEARING, RB/6004	6 15	BOLT/M 8X25	15 18
BEARING, RB/6004SS	12 5	BOLT/M 8X45	13 18
BEARING, RB/6005	6 16	BOLT/M06X16	16 2
BEARING, RB/6204	6 19	BOLT/M06X28	2 7A
BEARING, RB/6205	6 35	BOLT/M06X32	2 7
BEARING, RB/6206	6 27	BOLT/M06X32	2 11
BELT/VB066	20 5	BOLT/M08X20	15 6
BELT/VB066	20 1	BOLT/M10X25	23 18
BELT/VB078. 5	4 38A	BOLT/M10X30	4 3
BELT/VB079	4 38	BOLT/M10X60	10 8
BLADE/57X514	20 24	BOLT/M6X20	1 9
BLADE/57X514 COMP	20 24A	BOLT/M6X20	1 12
BLADE/57X514 COMP	23 20	BOLT/M8X16	25 3
BOLT	10 13	BOLT/M8X16	25 9
BOLT	4 36	BOLT/M8X20	6 12
BOLT(SP) M8X20	1 2	BOLT/M8X20	23 14
BOLT(SP) M8X20	1 14	BOLT/S	1 1

DESCRIPTION	FIG. KEY	DESCRIPTION	FIG. KEY
BOLT/S	6 32	CLIP(B)	15 20
BOOT	17 31	CLIP, PIN	21 4
BOOT	16 15	CLIP, PIN	21 18
BRACKET, BAR	4 46	CLIP, PIN	21 21
BRACKET/TENSION	4 11	CLSMP, WIRE/10-12	1 24A
BRACKET/TENSION COMP	4 11A	COLLAR/08X12X10	15 17
BREATHER, TANK CAP	1 20	COLLAR/11X15X07	14 2
BULB	8 4	COLLAR/20X30X03	6 29
BULB	12 4	COLLAR/20X30X03	6 34
BULB, LAMP/12V21W	17 3	COLLAR/21X25X46	12 6
BUSH, COLUMN	11 5	COLLAR/25X50X04	6 30
BUSH/10X12X10	11 2	COLLAR/42X47X13	6 14
BUSH/15X17X11	11 18	COLLAR/6.5X10.5X8	1 5
BUSH/15X17X15	13 2	COLUMN, STEERING ASSY	11 4
BUSH/15X17X21	9 2	COVER, BRAKE COMP	7 1
BUSH/16X24X21	21 23	COVER, CONNECTOR COMP	24 16
BUSH/18X20X15	5 16	COVER, DISCHARGE COMP	21 6
BUSH/18X20X15	7 19	COVER, DISCHARGE COMP	21 6A
BUSH/20X23X20	4 10	COVER, FRONT	15 2
BUSH/20X23X20	20 7	COVER, LOWER ASSY	11 1
CABLE, AXLE ASSY	3 1	COVER, PANEL	24 2
CABLE, BATTERY ASSY	2 10	COVER, PULLEY/LH	21 11
CABLE, EARTH	2 6	COVER, PULLEY/RH COMP	21 12
CABLE, PTO ASSY	13 10	COVER, REAR	9 3
CABLE, PTO ASSY	13 10A	COVER, SHOOTER ASSY	25 1
CAP	17 16	COVER, SHOOTER ASSY	25 1A
CAP, BATTERY	2 2	COVER, SWITCH	17 5
CAP, SHAFT(A)COMP	21 14	CUP, FUEL	1 25
CAP, TANK	1 19	DECK, MOWER/40 COMP	21 1
CAP, TIRE VALVE	8 3	DEK, MOWER/40 COMP	21 1A
CAP, TIRE VALVE	12 3	DEK, MOWER/40 COMP	21 2
CAP, WHEEL	8 9	DIODE/1.5A	17 14
CAP, WHEEL	12 10	DRUM, BRAKE	7 3
CASE, DIFF	6 24	FAN	23 1A
CASE, FAN	23 8	FAN, HST	4 42
CASE, TRANSMISSION/LH	6 1	FAN, SHIRKO ASSY	23 1
CASE, TRANSMISSION/RH	6 6	FENDER	16 1
CHASSIS, HST ASSY	9 1	FORK, WHEEL COMP	21 19
CHASSIS, HST ASSY	9 1A	FRAME	24 18
CHASSIS, HST ASSY	9 1B	FRAME, BAG COMP	24 19
CHASSIS, HST ASSY	9 1C	FRAME/A COMP	24 7
CLAMP, HARNESS	13 13	FRAME/B COMP	24 8
CLAMP, HARNESS	17 22	FRAME/C COMP	24 9
CLAMP, HARNESS	3 11	FUSE/32V10A	17 11
CLAMPER, 7 LONG	17 24	GASKET	1 21

CHASSIS

DESCRIPTION	FIG. KEY	DESCRIPTION	FIG. KEY
GAUGE, FUEL	1 22	KEY/05X05X24	4 34
GEAR, SHAFT/9-43TCOMP	6 18	KEY/06X07X63	4 2
GEAR/11T	6 21	KNOB	3 6
GEAR/12T	6 13	KNOB	13 16
GEAR/15T	6 20	LABEL	22 9
GEAR/25T ASSY	11 17	LABEL	22 10
GEAR/51T	6 22	LABEL (DANGER/F)	22 6
GRIP, BRAKE	7 24	LABEL, BELT CAUTION/D	19 4
GRIP, LIFT	14 21	LABEL, BELT CAUTION/D	19 4A
GROMMET	15 25	LABEL, BELT CAUTION/E	19 11
GROMMET	16 4	LABEL, BELT CAUTION/E	19 11A
GROMMET, PANEL	24 4	LABEL, BELT CAUTION/F	19 18
GROMMET/12X19	15 15	LABEL, BELT CAUTION/F	19 18A
GROMMET/48X68X02	1 27	LABEL, BELT CAUTION/F	19 25
GUIDE, BELT COMP	20 13	LABEL, BELT CAUTION/F	19 25A
GUIDE, DISCHARGE COMP	21 8	LABEL, CAUTION/D	19 5
GUIDE, MUFFLER COMP	1 13	LABEL, CAUTION/BATTERY	19 28
HANGER, SUPPORT	15 8	LABEL, CAUTION/E	19 12
HARNESS, MAIN ASSY	17 10	LABEL, DISCHARGE	22 4A
HARNESS, MAIN ASSY	17 10A	LABEL, DISCHARGE	22 7A
HARNESS, SENSOR ASSY	25 16	LABEL, DISCHARGE	22 10A
HINGE/102 COMP	16 6	LABEL, DISCHARGE	22 12A
HITCH, COLLECTOR COMP	23 17	LABEL, DISCHARGE/D	22 4
HOLDER, BAND	25 5	LABEL, DISCHARGE/F	22 7
HOLDER, BAND COMP	25 2	LABEL, FUSE/D	19 3
HOLDER, BATTERY	2 3	LABEL, FUSE/E	19 10
HOLDER/SWITCH	16 13	LABEL, FUSE/F	19 17
HOLDER/SWITCH	16 13A	LABEL, GAUGE WHEEL/D	22 5
HOOD COMP	15 1	LABEL, GAUGE WHEEL/E	22 11
HORN ASSY	25 18	LABEL, GAUGE WHEEL/F	22 8
HOSE/350	1 23	LABEL, LIFT LEVER	18 7
HOSE/600	1 26	LABEL, MODEL ASSY	18 5A
HST ASSY	4 39	LABEL, MODEL ASSY	22 1
HUB COMP	23 2	LABEL, MODEL ASSY	26 1
HUB, BLADE	20 25	LABEL, MODEL/SL14	18 5
HUB, BRAKE ASSY	7 18	LABEL, NOZZLE/100	18 8
HUB, STEERING COLUMN	11 6	LABEL, OPERATION/D	19 1
HUB, TRINION COMP	5 1	LABEL, OPERATION/D	19 1A
HUB/08X12X15	5 9	LABEL, OPERATION/E	19 8A
HUB/18X22X20	20 18	LABEL, OPERATION/F	19 15
INSULATOR/09X20X04	1 16	LABEL, OPERATION/F	19 15A
INSULATOR/20X35X01	4 48	LABEL, OPERATION/I	19 22
JOINT, BALL	10 30	LABEL, OPERATION/I	19 22A
JOINT, BALL/LH	10 21	LABEL, OPTION/E	19 19
JOINT, BALL/RH	10 22	LABEL, PARKING/D	19 2

DESCRIPTION	FIG. KEY	DESCRIPTION	FIG. KEY
LABEL, PARKING/E	19 8	LEVER, LIFT COMP	14 16
LABEL, PARKING/E	19 9	LEVER, PARKING COMP	7 23
LABEL, PARKING/F	19 16	LEVER, PTO COMP	13 15
LABEL, SWITCH	17 6	LEVER, PUSH	4 44
LABEL, WARNING/D	26 3A	LINING/13X50X3	3 10
LABEL, WARNING/E	26 4B	LINK COMP	14 1
LABEL, WARNING/F	26 5	LINK COMP	14 1A
LABEL, WARNING/D	26 3	LINK, FUSIBLE	2 13
LABEL, WARNING/E	26 4	LINK, NEWTRIL COMP	5 4
LABEL, WARNING/E	26 4A	MAT	15 19
LABEL, WARNING/I	26 6	METAL	20 16
LABEL/CAUTION/BELT	22 2	METAL	20 16A
LABEL/CAUTION/I	19 26	NET, FAN	23 9
LABEL/CAUTION/SROOP	18 12	NET, PANEL	24 3
LABEL/CE	18 9	NIPPLE, GREASE	10 6
LABEL/CE	19 32	NIPPLE, GREASE/B-M6F	10 7
LABEL/D/BATTERY	19 21	NUT	17 30
LABEL/D/BATTERY	19 7	NUT	16 16
LABEL/D/BATTERY	19 14	NUT	3 8
LABEL/D/FUEL/D	19 6	NUT	5 8
LABEL/D/FUEL/D	19 35	NUT	10 9
LABEL/D/FUEL/F	19 20	NUT	11 21
LABEL/D/FUEL/F	19 37	NUT	14 27
LABEL/D/FUEL/G	19 13	NUT	23 13
LABEL/D/FUEL/G	19 36	NUT	24 6
LABEL/D/FUEL/T	19 27	NUT	25 15
LABEL/DISCHARGE	22 3	NUT	16 20
LABEL/DISCHARGE	26 2	NUT	21 25A
LABEL/DISCHARGE	22 12	NUT, LOCK/M8	4 6
LABEL/FUSE/I	19 24	NUT, LOCK/M8	4 19
LABEL/HST	18 11	NUT, LOCK/M8	7 10
LABEL/HST	19 34	NUT, LOCK/M8	11 7
LABEL/MENTENANSU	18 10	NUT, LOCK/M8	16 7
LABEL/MENTENANSU	19 33	NUT, LOCK/M8	21 7
LABEL/PARKING/I	19 23	NUT, LOCK/M8	21 9
LABEL/SL/D SET	19 29	NUT, LOCK/M8	21 13
LABEL/SL/F SET	19 31	NUT, LOCK/M8	21 18A
LABEL/SL/G SET	19 30	NUT, LOCK/M8	25 4
LABEL/WHEEL, GAUGE/I	22 13	NUT, LOCK/M8	25 10
LABELCAUTION/HOT	18 13	NUT, RING	17 17
LAMP, HEAD ASSY	17 1	NUT/LH M10X1.25	10 23
LEAD	17 2	NUT/M 6	2 5
LENS	17 8	NUT/M 6	16 18
LEVER, AXLE COMP	3 4	NUT/M 8	2 15
LEVER, FRAME COMP	24 12	NUT/M 8	4 18

CHASSIS

DESCRIPTION	FIG. KEY	DESCRIPTION	FIG. KEY
NUT/M 8	4 32	PIN, SPLIT/2. 5X15	3 3
NUT/M 8	5 5	PIN, SPLIT/2. 5X20	10 28
NUT/M 8	7 17	PIN, SPLIT/2. 5X20	11 12
NUT/M 8	13 20	PIN, SPLIT/2. 5X20	11 16
NUT/M 8	14 15	PIN, SPLIT/2. 5X25	12 9
NUT/M 8	16 10	PIN, SPLIT/2. 5X25	14 4
NUT/M 8	20 12	PIN, SPLIT/2. 5X25	14 11
NUT/M 8	20 20	PIN, SPLIT/2. 5X25	14 26
NUT/M06	2 8	PIN, SPLIT/3 X15	5 11
NUT/M06	2 12	PIN, SPLIT/3 X15	5 14
NUT/M08	15 7	PIN, SPLIT/3 X15	7 16
NUT/M10	10 14	PIN, SPLIT/3 X15	13 12
NUT/M10	10 24	PIN, SPLIT/3 X20	1 18
NUT/M10X1.25	10 25	PIN, SPLIT/3 X20	24 10
NUT/M10X1.25	11 10	PIN, SPLIT/3 X20	24 14
NUT/M10X1.25	11 14	PIN, SPLIT/3 X25	4 25
NUT/M10X1.25	12 8	PIN, SPLIT/3 X25	5 18
NUT/M12	14 7	PIN, SPLIT/3 X25	10 5
NUT/M12X1.25	10 4	PIN, SPLIT/3 X25	10 35
NUT/M12X1.25	10 32	PIN, SPLIT/3 X25	13 5
NUT/M12X1.25	10 31	PIN, SPLIT/3 X30	7 21
NUT/M14	23 5	PIN, SPLIT/3 X30	8 8
NUT/M14	20 28	PIN, SPLIT/3 X30	21 25
NUT/M14X1.5	8 7	PIN, SPRING/4 X20 W	24 21
NUT/M6	15 3	PIN, SPRING/6 X25 W	5 2
NUT/M6	16 3	PIN, SPRING/6 X40 W	4 23
O-RING/G45	6 17	PIN, STOPPER ASSY	21 5
O-RING/P 8	6 11	PIN/08X44	21 20
ORNAMENT (HYDRAULIC)	18 6	PIN/12X104	21 17
ORNAMENT/14	18 3	PIN/12X108	21 17A
ORNAMENT/14	18 3A	PIN/12X108	21 17B
ORNAMENT/F	18 4	PIN/12X22	21 3
ORNAMENT/F	18 4A	PIN/15X47	7 8
ORNAMENT/LH	18 1	PIN/16X88	21 24
ORNAMENT/RH	18 2	PIN/16X94	21 24A
PAD, PEDAL	5 17	PIN/16X94	21 24B
PAD, STEERING WHEEL	11 9	PIN/22X77	10 2
PANEL, CONNECTOR COMP	24 1	PIN/M12X43	14 5
PANEL, INSTRUMENT	15 21	PIPE, SHOOTER ASSY	25 7
PEDAL, HST ASSY	5 15	PIPE, SHUTER COMP	25 8
PEDL B	7 22	PLATE	14 18
PIN (10X18)	6 25	PLATE	16 19
PIN, DIFF PINION	6 23	PLATE	25 13
PIN, PUSH	14 20	PLATE COMP	15 10
PIN, ROLL	4 45	PLATE, ADJUST	5 7

DESCRIPTION	FIG. KEY	DESCRIPTION	FIG. KEY
PLATE, FAN	23 10	ROD/M10X246	14 24
PLATE, L/32X154	14 23	ROD/M10X505 COMP	5 12
PLATE, PTO LEVER	13 17	S. W	4 37
PLATE, U/79X22	14 12	S. W	16 17
PLATE/I/19X78 COMP	4 20	SCREW M4X6	17 18
PLATE/IR/22X29C	1 4	SCREW SEENS/M6X16	15 22
PLATE/IR/54X156	25 6	SCREW/M3X16	17 26
PLUG	23 19	SCREW/M6X20	1 6
PLUG, DRAIN (1/4)	6 9	SCREW/M6X20	1 8
PLUG, OIL	6 4	SCREW/M6X20	1 11
PULLEY, TENSION	4 7	SCREW/M6X20	15 23
PULLEY, TENSION	4 12	SEAL, OIL/TC20357	6 8
PULLEY, TENSION/045	4 26A	SEAL, OIL/TC25408	6 2
PULLEY, TENSION/045	4 26	SEAL, OIL/TC25408	6 7
PULLEY, TENSION/045	13 6	SEAL/15X15X320	15 5
PULLEY/FT/85X22 COMP	20 8	SEAL/20X20X70	23 16
PULLEY/TENSION	4 14	SEAT ASSY	16 12
PULLEY/V2B120	20 2	SEAT ASSY	16 12A
PULLEY/V2B120B90	4 1	SENSOR ASSY	25 11
PULLEY/VB105	4 33	SHAFT STEERING COMP	11 13
PULLEY/VB120 COMP	20 22	SHAFT, WHEEL/LH	6 28
PULLEY/VB120 COMP	20 23	SHAFT, WHEEL/RH	6 33
REFLECTER	16 5	SHIM/1.2	20 26
RELAY, 4P ASSY	17 12	SHOE, BRAKE ASSY	7 6
RELAY, 5P ASSY	17 13	SHROUD, LOWER COMP	1 7
RING, SNAP, S80	6 26	SHROUD, UPPER COMP	1 3
RING, SNAP/12 C	4 8	SPRING	24 13
RING, SNAP/12 C	4 13	SPRING, BRAKE SHOE	7 7
RING, SNAP/12 C	7 5	SPRING, CHAIN TENSION	20 10
RING, SNAP/15 C	4 29	SPRING, CLUTCH RETURN	21 10
RING, SNAP/15 C	13 7	SPRING, DISK	3 7
RING, SNAP/17 C	20 9	SPRING, HEO66	13 3A
RING, SNAP/35 C	4 28	SPRING, HYD CLUTCH	7 13
RING, SNAP/40 C	20 19	SPRING, MAIN CLUTCH	4 31
RING, SNAP/20	4 15	SPRING, MAIN CLUTCH	4 16
RING, SNAP/20	1C 18	SPRING, MAIN CLUTCH	4 31A
RING, SNAP/20	20 4	SPRING, RETURN	14 13
ROD	4 17A	SPRING, SHUTTER	24 17
ROD	4 17	SPRING, TENSION	7 11
ROD	20 11	SPRING, TENSION/46	13 3
ROD, DRUG	10 29	SPRING, TENSION/86	5 6
ROD, TIE	10 20	SPRING, TENSION/86	7 25
ROD/M08X295	4 30	SPRING/D=6	16 8
ROD/M08X555	7 14	SPRING/HCO57	14 22
ROD/M08X751	14 9	SPRING/HE014	13 14

CHASSIS

DESCRIPTION	FIG. KEY	DESCRIPTION	FIG. KEY
SPRING/HE047	3 5A	WASHER, PULLEY	10 3
SPRING/HE049	3 5	WASHER, ROOT TENSION	14 6
SPRING/HE100	14 28	WASHER, SP/M 3	17 27
STAY, SHROUD COMP	1 10	WASHER, SP/M 4	17 19
STEP	15 14	WASHER, SP/M 8	2 14
STOPPER BELT COMP	13 8	WASHER, SP/M 8	16 11
SWITCH, HEAD LAMP	17 4	WASHER, SP/M 8	20 21
SWITCH, KEY ASSY	17 20	WASHER, SP/M10	10 27
SWITCH, MERIT	17 25	WASHER, SP/M10	11 20
SWITCH, PUSH	17 29	WASHER, SP/M12	10 34
SWITCH, PUSH SET	17 29A	WASHER, SP/M12	14 8
SWITCH, SEAT ASSY	36 14A	WASHER, SP/M14	20 29
SWITCH, SEAT ASSY	16 14	WASHER, SP/M14	23 6
SWITCH, STARTER SET	17 15	WASHER, THROWER	23 12
TANK, FUEL	1 15	WASHER/06X16X01	15 24
TIRE, TURF/14-5	12 1	WASHER/11X30X3	10 12
TIRE, TURF/18-8.5	8 1	WASHER/11X30X3	11 15
TRIM/1X06X540	15 4	WASHER/11X30X3	11 19
TUBE/140	6 3	WASHER/11X30X3	12 7
WASHER	10 15	WASHER/11X44X5	4 4
WASHER	10 19	WASHER/14X47X07	8 6
WASHER	15 16A	WASHER/14X55X05	20 27
WASHER	4 35	WASHER/20X28X2	10 17
WASHER (9X24X1.6)	15 16	WASHER/6X14X3	17 9
WASHER / M6	3 2	WASHER/9X22X2	23 15
WASHER /M12	7 4	WASHER/9X32X2	16 9
WASHER /M12	10 33	WASHER/M10	3 9
WASHER /M12	14 3	WASHER/M10	10 26
WASHER /M12	14 25	WASHER/M10	11 11
WASHER /M12	24 11	WASHER/M18	7 20
WASHER /M12	24 15	WASHER/M3	17 28
WASHER, CAM	20 15	WHEEL, GAUGE FRONT	21 16
WASHER, HOLDER COVER	23 4	WHEEL, STEERING ASSY	11 8
WASHER, PL/M 8	1 17	WHEEL/3. 5X6 COMP	12 2
WASHER, PL/M 8	5 10	WHEEL/3. 5X6 COMP	12 2A
WASHER, PL/M 8	5 13	WHEEL/7. 0X8 COMP	8 2
WASHER, PL/M 8	7 15	WHEEL/7. 0X8 COMP	8 2A
WASHER, PL/M 8	13 11	WHEEL/GAUGE/REAR	21 22
WASHER, PL/M 8	13 19	WIRE/1. 2X100	5 3
WASHER, PL/M 8	14 10	WRENCH/PLUG	19 38
WASHER, PL/M 8	14 14		
WASHER, PL/M14	4 24		
WASHER, PL/M14	8 5		
WASHER, PL/M14	13 4		
WASHER, PL/M14	23 7		



**Yvan Beal - 21, av. de l'Agriculture - B.P. 16
Z.I. du Brézet - 63014 Clermont-Ferrand Cedex 2
Tél : 04 73 91 93 51 - Télécopie : 04 73 90 23 11
www.yvanbeal.fr - E-mail : info@yvanbeal.fr
R.C.S. Clermont-Fd B 304 973 886 - S.A.S. au capital de 612 000 €**