

ILLUSTRATED PARTS LIST

MODEL NO. 96051012400

CUSTOMER CATALOG NO. TC 138

PRODUCT NO. 960 51 01-24

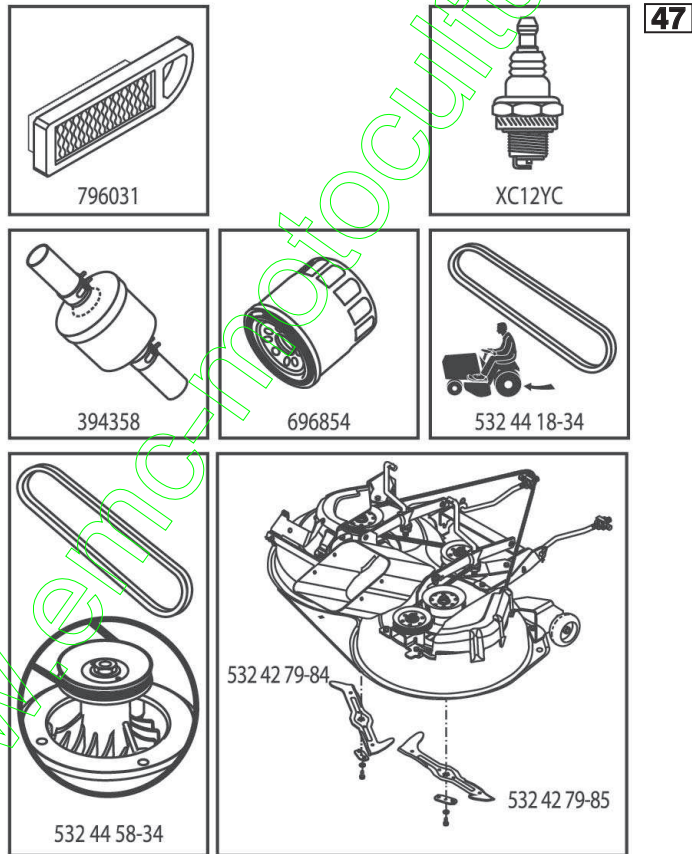

587396101

**TRACTOR - - MODEL NO. TC 138 (96051012400), PRODUCT NO. 960 51 01-24
DECALS 27**

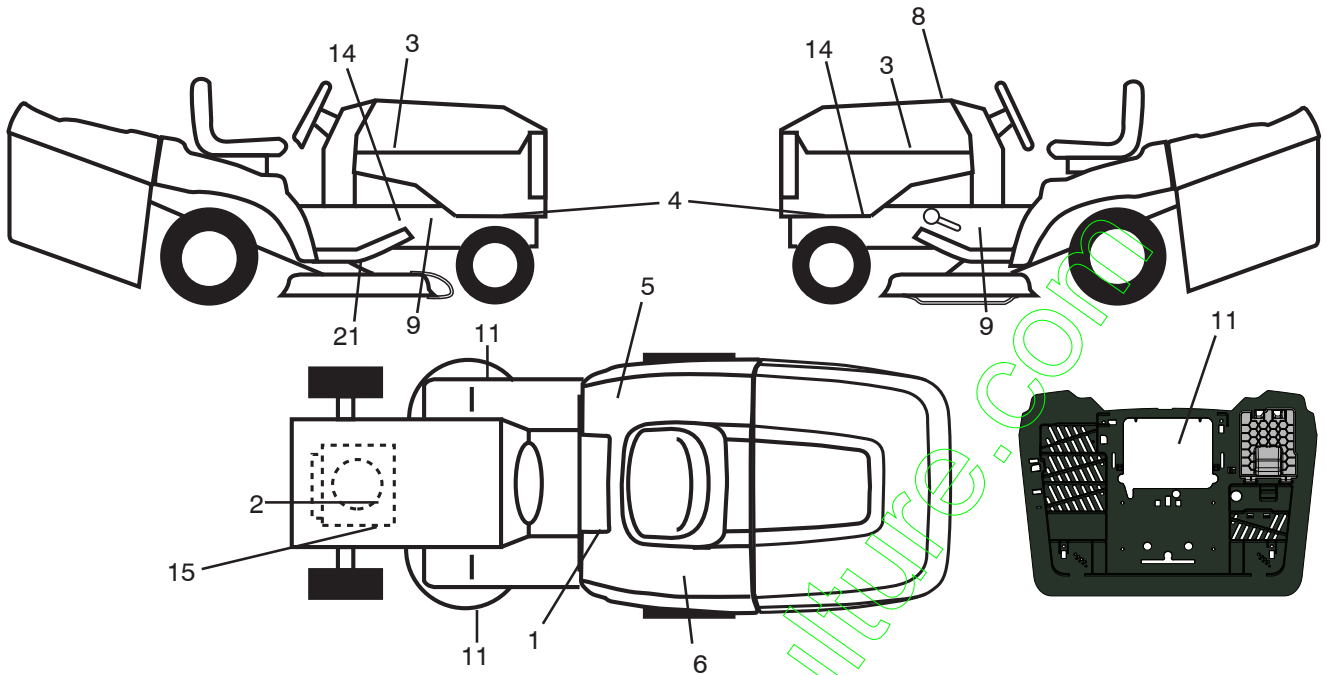

KEY NO.	PART NO.	DESCRIPTION
1	581 57 83-01	Decal, Warning
2	581 57 97-01	Decal, Warning Eng. Sym.
3	581 62 73-01	Decal, Hood RH/LH
4	587 40 71-01	Decal, Side Panel
5	586 06 62-01	Decal, Snowflake
6	581 72 41-01	Decal, 100 DB/CE
8	587 39 61-01	Decal, Replacement
9	581 57 98-01	Decal, Warning
11	581 57 91-01	Decal, Mower Cut Finger Symbol
14	581 57 96-01	Decal, Chassis Hot Muffler
15	587 73 12-01	Decal, Engine HP

KEY NO.	PART NO.	DESCRIPTION
21	532 44 11-89	Decal, Belt Sch CRD
--	532 44 27-44	Decal, Battery
--	532 44 14-10	Pad Footrest RH
--	532 44 14-09	Pad Footrest LH
--	581 72 48-01	Decal, Bypass
--	532 44 32-61	Decal, Inst. Mulch Plug
--	587 40 66-40	Manual Operator's (Euro)
--	587 40 66-50	Manual Operator's (Scan)
--	587 40 66-20	Manual Operator's (E-Bloc)
--	587 40 66-30	Manual Operator's (Baltic)

WHEELS & TIRES

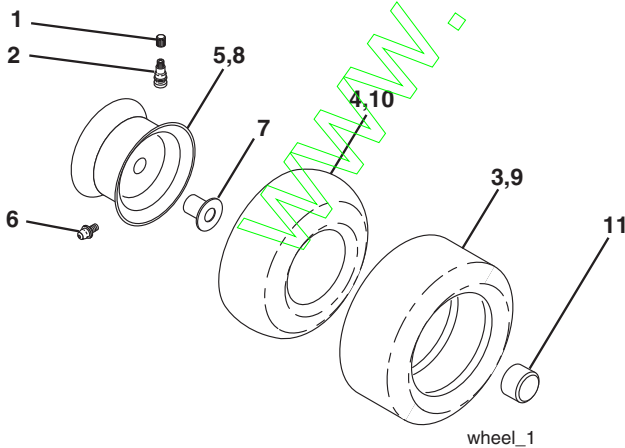

KEY NO.	PART NO.	DESCRIPTION
1	532 05 91-92	Cap Valve Tire
2	532 06 51-39	Stem Valve
3	532 10 62-22	Tire Front 15 x 6-6
4	532 05 99-04	Tube Inner Front #35060
5	532 13 83-36	Rim Asm 6" Front
6	532 12 49-57	Fitting Grease
7	532 12 49-59	Bearing Flange
8	532 13 83-37	Rim Asm 8" Rear
9	532 12 46-35	Tire Rear 18 x 8.5-8
10	532 12 49-26	Tube Rear 8.5 x 8
11	532 17 50-39	Cap Axle
--	532 14 43-34	Sealant, Tire (10 oz. Tube)

NOTE: All component dimensions given in U.S. inches
1 inch = 25.4 mm

TRACTOR - - MODEL NO. TC 138 (96051012400), PRODUCT NO. 960 51 01-24 SCHEMATIC **38**

SCH17

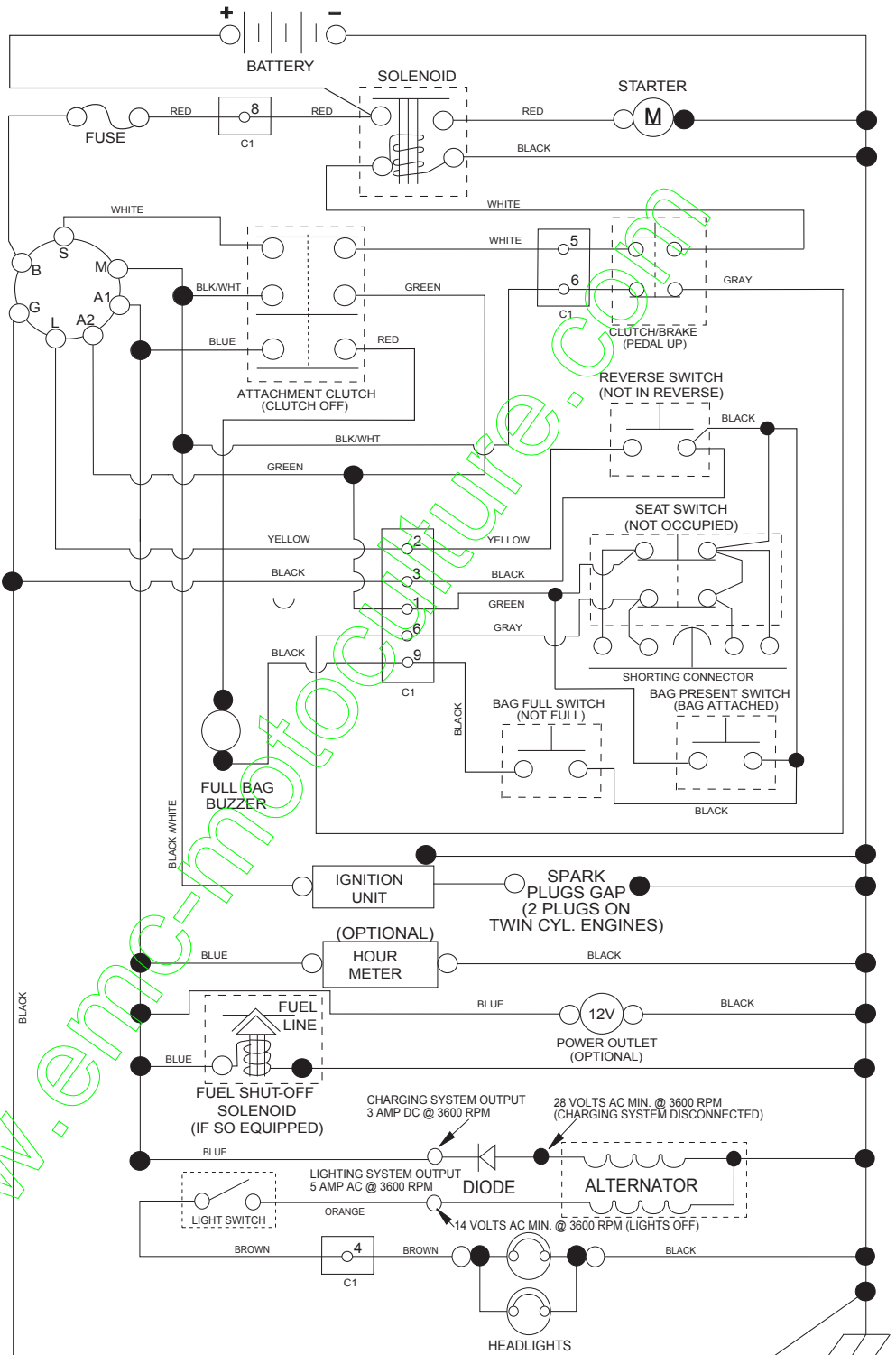

NOTE
YOUR TRACTOR IS EQUIPPED WITH A SPECIAL ALTERNATOR SYSTEM. THE LIGHTS ARE NOT CONNECTED TO THE BATTERY, BUT HAVE THEIR OWN ELECTRICAL SOURCE. BECAUSE OF THIS, THE BRIGHTNESS OF THE LIGHTS WILL CHANGE WITH ENGINE SPEED. AT IDLE THE LIGHTS WILL DIM. AS THE ENGINE SPEED IS INCREASED, THE LIGHTS WILL BECOME THEIR BRIGHTEST.

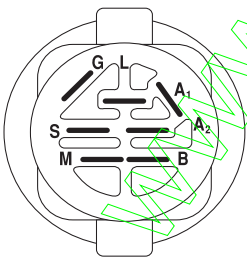

IGNITION SWITCH

POSITION	CIRCUIT	"MAKE"
OFF	M+G+A1	
RUN/OVERRIDE	B+A1	
RUN	B+A1	L+A2
START	B + S + A1	

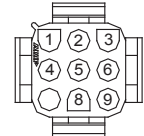

CHASSIS HARNESS CONNECTOR (C1) (MATING SIDE)

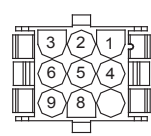

DASH HARNESS CONNECTOR (C1) (MATING SIDE)

WIRING INSULATED CLIPS
NOTE: IF WIRING INSULATED CLIPS WERE REMOVED FOR SERVICING OF UNIT, THEY SHOULD BE RE-INSTALLED TO PROPERLY SECURE YOUR WIRING.

● NON-REMOVABLE CONNECTIONS

○ REMOVABLE CONNECTIONS

TRACTOR - - MODEL NO. TC 138 (96051012400), PRODUCT NO. 960 51 01-24
ELECTRICAL 32

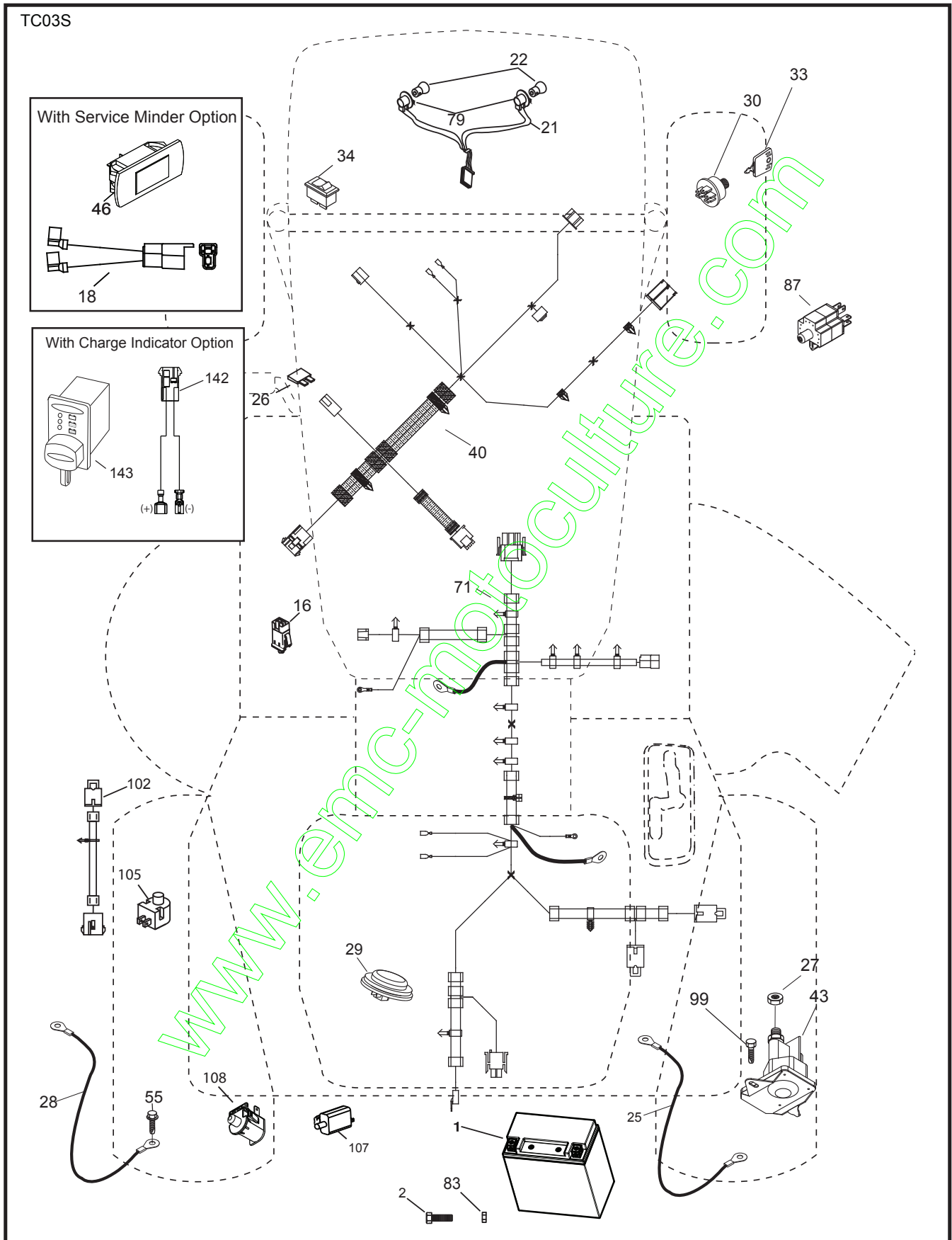

**TRACTOR - - MODEL NO. TC 138 (96051012400), PRODUCT NO. 960 51 01-24
ELECTRICAL 32**

KEY NO.	PART NO.	DESCRIPTION
1	532 43 71-57	Battery
2	532 44 09-23	Screw Hex Hd Cap M6 x 1.12mm
16	532 17 61-38	Switch Interlock
21	532 40 02-52	Harness Asm Light w/4152J
22	532 00 41-52	Bulb Light #1156
25	581 48 98-01	Cable Battery Red
26	532 17 51-58	Fuse
27	873 51 04-00	Nut Keps Hex 1/4-20 unc
28	581 48 98-02	Cable Ground Black
29	532 40 15-45	Switch Seat
30	532 19 33-50	Switch Ignition
33	532 41 19-35	Key/Chain
34	532 11 07-12	Switch Light
40	585 84 99-01	Harness Ignition Dash
43	532 19 25-07	Solenoid
55	817 06 05-12	Screw 5/16-18 x 3/4
71	587 26 87-01	Harness Chassis
79	532 17 52-42	Socket Asm.
83	532 43 67-74	Nut Square M6 x 1 x 8.5 x 11mm
87	532 42 10-60	Switch Railmount
99	817 67 04-12	Screw Hexwsh
102	532 44 12-62	Harness Jumper
105	532 40 75-68	Switch Reverse
107	532 18 03-79	Switch Full Bagger Indicator
108	532 42 10-62	Switch Snapmount
142	583 85 78-01	Charge Port Pigtail
143	532 44 80-59	Charge Port

NOTE: All component dimensions given in U.S. inches
1 inch = 25.4 mm

**TRACTOR - - MODEL NO. TC 138 (96051012400), PRODUCT NO. 960 51 01-24
CHASSIS AND ENCLOSURES 39**

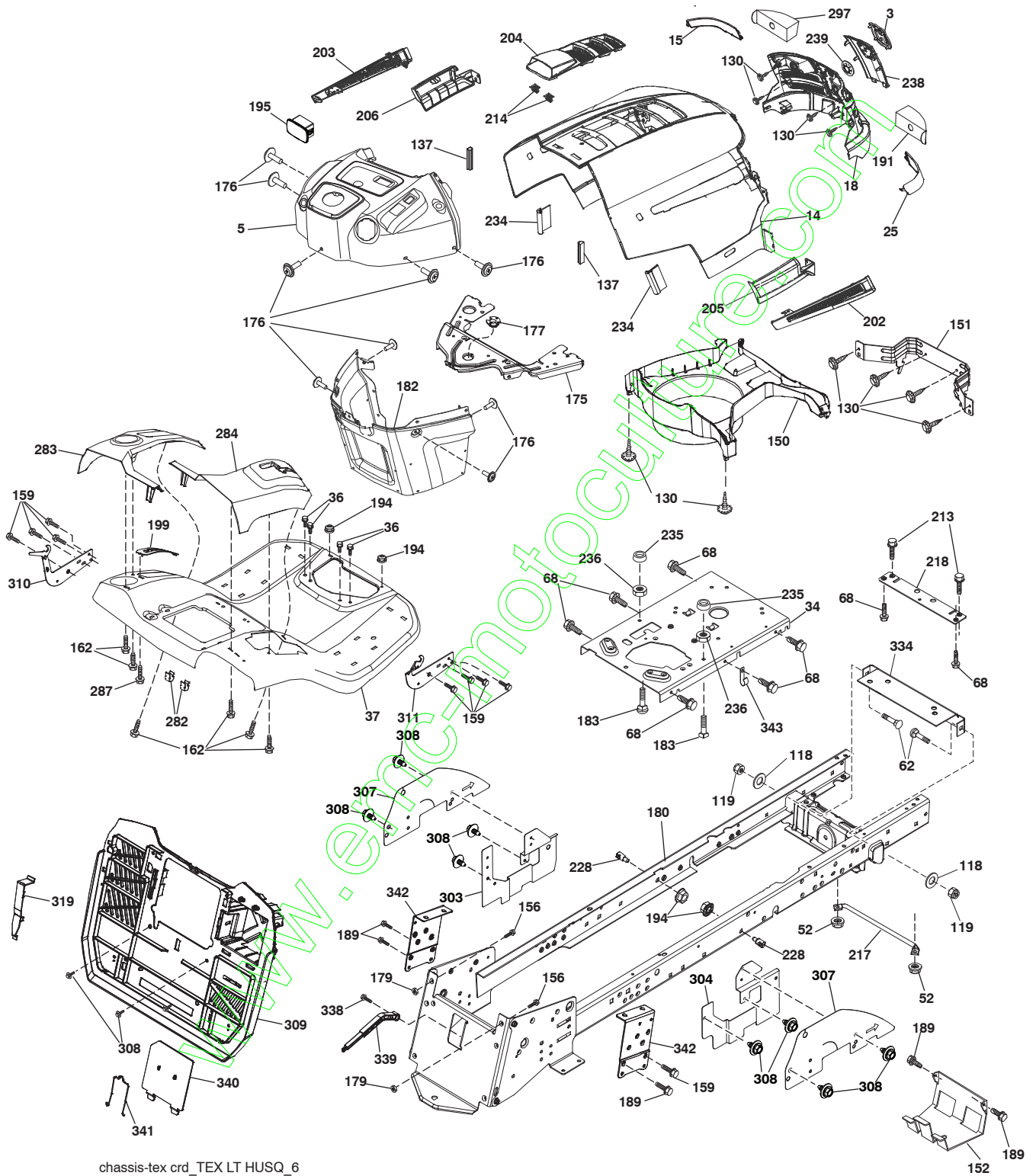

chassis-tex crd_TEX LT HUSQ_6

**TRACTOR - - MODEL NO. TC 138 (96051012400), PRODUCT NO. 960 51 01-24
CHASSIS AND ENCLOSURES **39****

KEY NO.	PART NO.	DESCRIPTION	KEY NO.	PART NO.	DESCRIPTION
3	581 05 63-01	Logo	204	532 44 13-75	Vent Top Hood
5	585 52 98-06	Dash	205	532 44 13-44	Skirt Side RH
14	532 44 12-67	Hood	206	532 44 13-45	Skirt Side LH
15	532 44 14-28	Lens LH	213	874 76 05-12	Bolt Hex HD 5/16-18 unc 3/4
18	532 44 13-68	Grille	214	532 19 91-45	Clip Retainer
25	532 44 14-27	Lens RH	217	532 40 91-67	Rod Pivot Hood
34	580 91 09-01	Plate Engine	218	532 19 63-95	X-Piece Hood Stop
36	817 06 05-12	Screw 5/16-18 x 3/4	228	532 19 51-61	Stud Fastener
37	532 44 13-69	Fender	234	532 40 47-42	Bumper Hood
52	873 68 05-00	Nut Crownlock 5/16-18	235	532 40 61-29	Spacer Fender
62	872 11 06-08	Bolt 3/8-16 x 1 Gr. 5	236	873 93 05 00	Nut Center Lock 5/16-18 unc
68	817 49 05-08	Screw Thdrol. 5/16-18 x 1/2	238	532 44 13-74	Trim
118	819 13 13-16	Washer 13/32 x 13/16 x 1/6	239	532 40 48-83	Clip Tinnerman
119	873 68 06-00	Nut Crown Lock	282	532 41 41-10	Clip Retainer
130	532 41 63-58	Screw #10 x .750 BOS Thread	283	532 44 05-31	Console Deck Lift
137	532 40 75-90	Bumper Dash	284	532 44 05-30	Console Shift RH
150	532 40 66-62	Air Duct	287	817 60 04-06	Screw Hex Washead. 1/4-20 x 3/8
151	532 40 78-07	Bracket Pivot	297	532 40 66-65	Insert Reflective LH
152	532 19 95-35	Shield Browning	303	587 49 31-01	Shield LH
156	872 14 06-14	Bolt 3/8-16 unc x 1-3/4	304	587 49 33-01	Shield RH
159	817 00 06-12	Screw 3/8-16 x 3/4	307	587 49 45-01	Shield Upper
162	532 14 24-32	Screw Hex Wsh. Hi-Lo 1/4 x 1/2 unc	308	532 17 18-77	Bolt 5/16-18 unc x 3/4
175	532 19 94-72	Crossmember	309	584 44 11-01	Backplate
176	532 40 07-76	Screw 10-24 x 5/8	310	532 44 66-36	Bracket Hangbar Bag LH
177	532 19 52-28	Bushing Steering	311	532 44 66-37	Bracket Hangbar Bag RH
179	532 16 89-37	Nut Push	319	532 17 46-62	Bracket Actuator Bagger
180	532 19 54-38	Chassis	334	532 44 25-37	Bracket Engine
182	532 40 71-76	Dash Lower	338	532 43 66-40	Bolt Shoulder
183	874 52 05-20	Bolt 5/16-18 x 1-1/4	339	532 43 66-41	Lever Bagger Full
189	817 00 05-12	Screw 5/16-18 x 3/4	340	532 44 09-31	Door Battery Tray
191	532 41 65-01	Insert Reflective RH	341	532 43 66-38	Latch Batter Tray
194	873 90 05-00	Nut Lock Hex Flange 5/16-18	342	532 43 59-38	Support Fender
195	532 43 99-76	Plug Dash	343	532 44 07-49	Clip
199	532 41 87-39	Plate Deck Lift			
202	532 44 13-42	Vent Side Hood RH			
203	532 44 13-43	Vent Side Hood LH			

NOTE: All component dimensions given in U.S. inches
1 inch = 25.4 mm

www.emc-motors.com

TRACTOR -- MODEL NO. TC 138 (96051012400), PRODUCT NO. 960 51 01-24
 DRIVE **40**

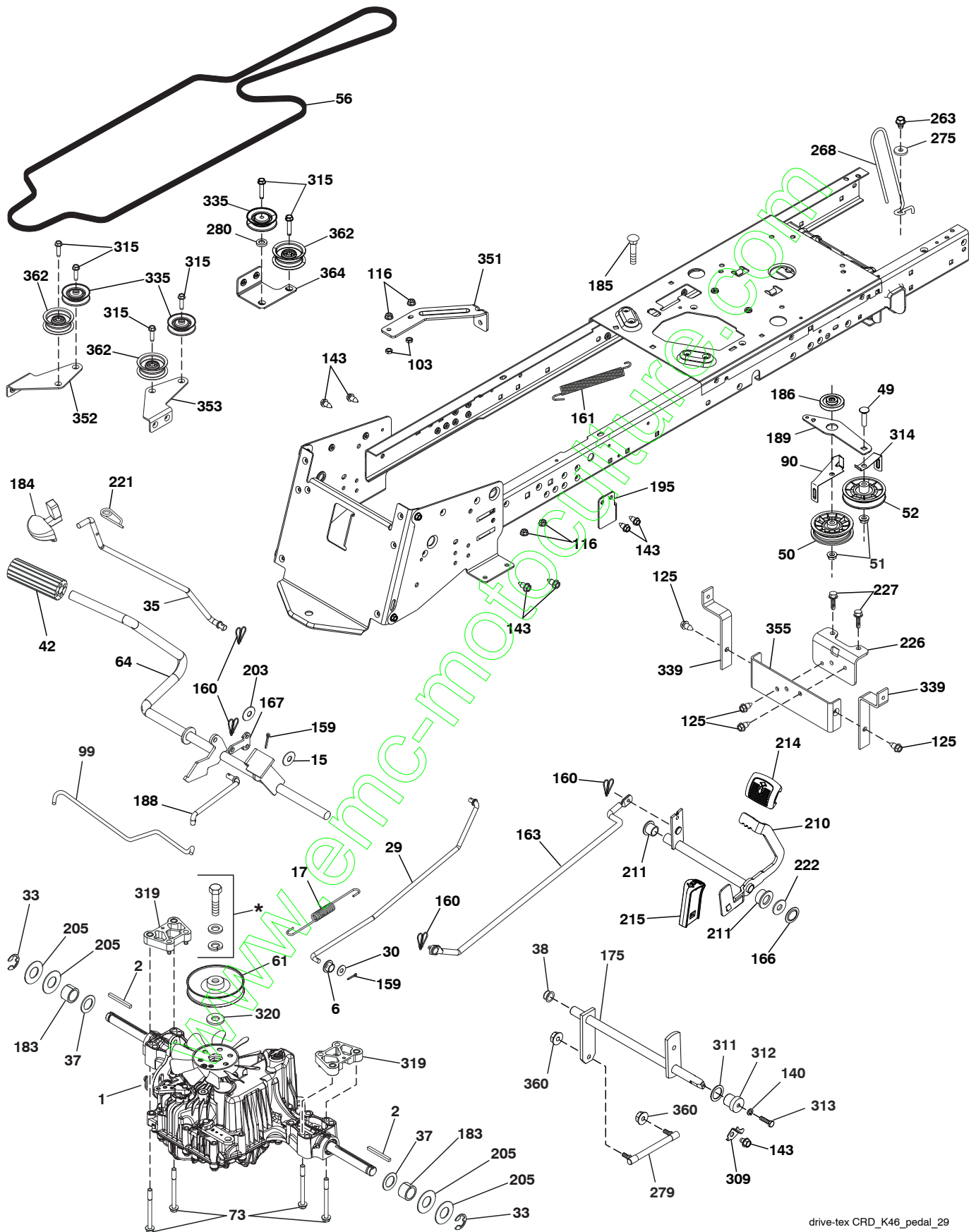

drive-tex CRD_K46_pedal_29

TRACTOR - - MODEL NO. TC 138 (96051012400), PRODUCT NO. 960 51 01-24

DRIVE 40

KEY NO.	PART NO.	DESCRIPTION	KEY NO.	PART NO.	DESCRIPTION
1	-----	Transaxle, TUFFTORQ K46 DF (446488) (Order parts from trans-axle manufacturer.)	195	580 45 69-01	Bracket Brake Rod
2	532 12 35-83	Key Square	203	819 11 11-16	Washer 11/32 x 11/16 x 16 Ga.
6	532 12 40-28	Bushing Snap	205	532 12 17-48	Washer 25/32 x 1-5/8 16 Ga.
15	819 13 13-16	Washer 13/32 x 13/16 x 16 Ga.	210	532 40 09-80	Rocker Asm. Pedal
17	532 43 62-27	Spring, Brake	214	532 42 12-63	Pedal Forward
29	532 43 58-81	Rod, Brake	215	532 41 94-82	Pad Pedal Reverse
30	819 13 16-16	Washer 13/32 x 1 x 16 Ga.	211	532 12 01-83	Bearing Nylon
33	812 00 00-01	Ring E	221	532 40 31-87	Retainer Spring
35	532 40 10-31	Rod, Brake, Park	222	879 21 20-10	Washer Flat
37	532 18 89-67	Washer .793 x 1.637 x 060	226	532 40 15-64	Bracket Mount Torque
38	532 16 96-13	Nylon Snap In	227	817 49 05-12	Screw
42	532 12 48-72	Cover, Foot Pedal	263	817 00 06-12	Screw Hexwsh Thdr 3/8-16 x 3/4
49	872 11 06-14	Bolt 3/8-16 unc	268	532 18 24-02	Guard Muffler
50	532 19 43-27	Idler Flat	275	819 13 16-14	Washer 13/32 x 1 x 14 Ga.
51	873 90 06-00	Lock Nut 3/8-16	279	532 44 42-83	Link Shift Hydro
52	532 19 43-26	Idler V-Groove	280	819 11 10-12	Washer 11/32 x 5/8 x 12 Ga.
56	532 44 18-34	V-Belt, Drive	309	532 16 55-81	Plate Fstnr.
61	532 43 77-88	Pulley Transaxle	311	532 16 98-45	Washer Nylon
64	532 19 78-65	Shaft Asm. Pedal Brake Control	312	532 16 56-14	Hub Tapered
73	874 49 05-56	Bolt Hex 5/16-18 x 3.75	313	874 78 04-16	Bolt Hex Fin 1/4-20 unc x 1.GD5
90	532 44 36-05	Keeper Belt Clutching	314	532 44 47-13	Retainer, Belt
99	532 44 39-47	Rod Bypass	315	817 58 05-20	Screw Thdrol 5/16-18 x 4.25
103	873 35 05-00	Nut 5/16-18 unc	319	532 43 67-94	Spacer Transaxle Tex CRD
116	873 90 05-00	Nut Lock Hex Flange 5/16-18	320	532 18 76-90	Washer Spacer
125	817 00 05-12	Screw 5/16-18 x 3/4	335	532 19 95-34	Pulley V Idler Ground Drive
140	810 04 04-00	Washer Lock Hvy. Helical 1/4	339	532 43 68-67	Strap Torue K46 CRD Tex
143	817 49 05-08	Screw Thdrol 5/16-18 x 1/2 TYTT	351	532 43 69-98	Bracket Deck Sway
159	876 02 04-12	Pin Cotter 1/8 x 3/4	352	532 43 58-19	Bracket Idler
160	532 16 94-84	Retainer Clip	353	532 43 65-77	Bracket Idler RH
161	532 10 57-09	Spring, Return, Clutch	355	532 43 56-69	Strap Torque
163	532 43 66-32	Rod Control	360	532 44 47-14	Nut Hex 5/16-24
166	532 42 91-64	Nut Push .625	362	532 43 68-12	Idler Flat
167	532 40 52-57	Latch Brake Parking	364	532 44 30-32	Bracket Idler
175	532 42 93-59	Shaft Asm. Cross Shift			
183	532 13 70-57	Spacer Axle			
184	532 41 14-84	Handle Park Brk.			
185	872 11 06-22	Bolt 3/8-16 unc x 2-3/4			
186	532 19 43-21	Spacer Retainer			
188	532 19 43-23	Link Clutch Ground Drive			
189	532 43 36-11	Bellcrank Ground Drive			

* Parts supplied by manufacturer

NOTE: All component dimensions given in U.S. inches
1 inch = 25.4 mm

www.tmc-motors.com

TRACTOR - - MODEL NO. TC 138 (96051012400), PRODUCT NO. 960 51 01-24
ENGINE 24

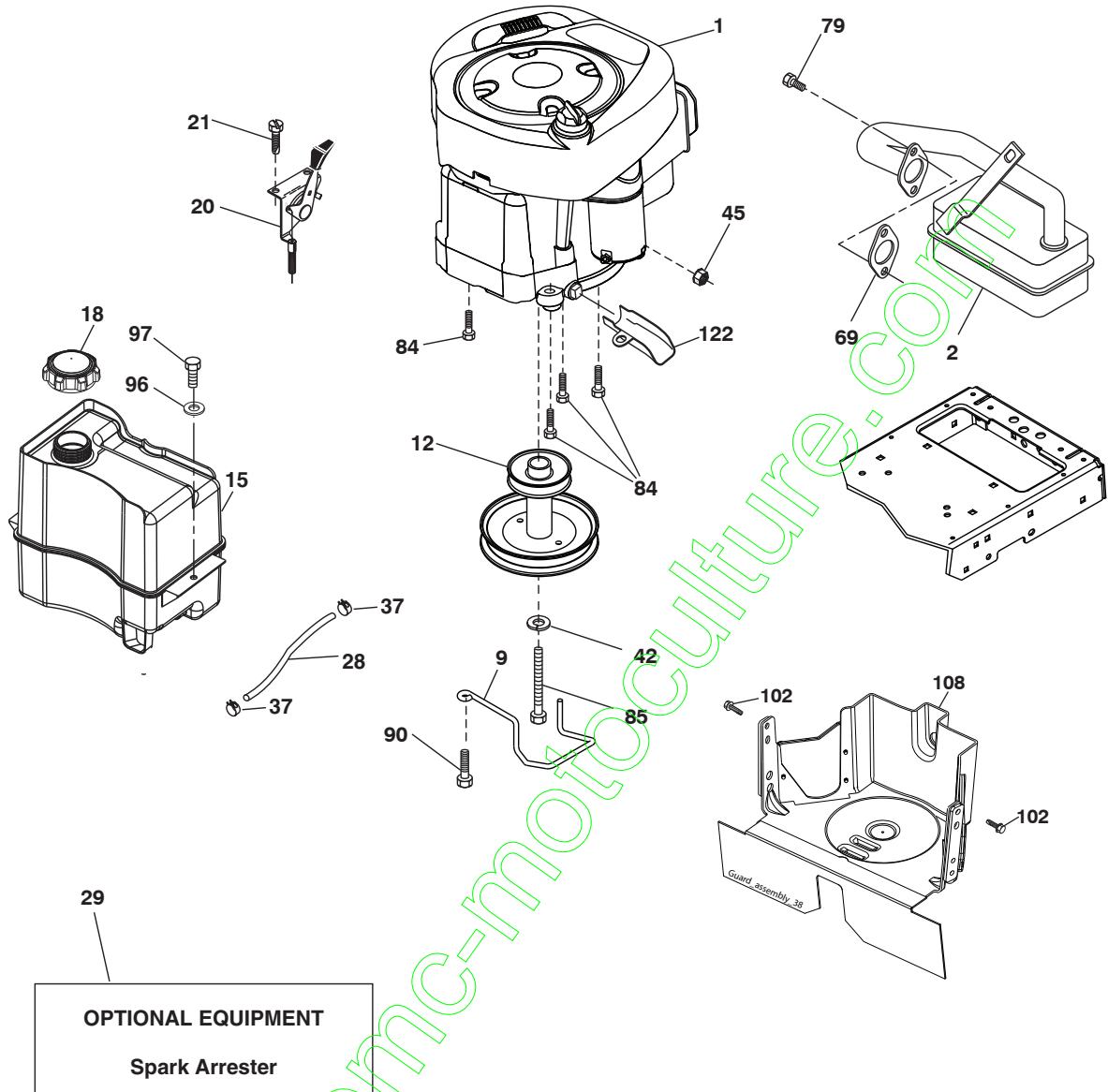

engine-tex_BS_82

**TRACTOR - - MODEL NO. TC 138 (96051012400), PRODUCT NO. 960 51 01-24
ENGINE 24**

KEY NO.	PART NO.	DESCRIPTION
1	-----	Engine B&S Model No. 31R577-0027 B1(587333501) (Order parts from engine manufacturer.)
2	532 13 73-52	Muffler
9	584 90 80-01	Keeper Belt Engine
12	532 40 54-71	Pulley Engine
15	581 28 99-01	Tank Fuel 1.5
18	532 43 02-20	Cap Fuel
20	532 18 38-97	Control Throttle
21	532 41 63-58	Screw #10 x 0.750 BOS Thread
28	532 13 70-40	Fuel Line
29	532 13 71-80	Spark Arrester Kit
37	532 12 34-87	Clamp Hose
42	810 04 07-00	Lock Washer Hvy. 7/16
45	873 51 04-00	Nut Keps Hex 1/4-20 unc
69	532 16 52-91	Gasket
79	532 19 23-34	Screw Socket HD 5/16-18 x .75
84	817 06 06-20	Screw
85	532 17 39-37	Bolt Hex 7/16-20 x 4 x Gr. 5-1.5 Thr
90	817 00 06-16	Screw 3/8-16 x 1
96	819 09 14-16	Washer 9/32 x 7/8 x 16 Ga.
97	817 67 04-12	Screw 1/4-20 x 3/4
102	817 06 05-16	Screw 5/16-18 x 1
108	532 42 30-41	Cover Pulley Engine
122	532 42 19-22	Extension Drain Oil

NOTE: All component dimensions given in U.S. inches
1 inch = 25.4 mm

Engine Power Rating Information

The gross power rating for individual gas engine models is labeled in accordance with SAE (Society of Automotive Engineers) code J1940 (Small Engine Power & Torque Rating Procedure), and rating performance has been obtained and corrected in accordance with SAE J1995 (Revision 2002-05). Torque values are derived at 3060 RPM; horsepower values are derived at 3600 RPM. Actual gross engine power will be lower and is affected by, among other things, ambient operating conditions and engine-to-engine variability. Given both the wide array of products on which engines are placed and the variety of environmental issues applicable to operating the equipment, the gas engine will not develop the rated gross power when used in a given piece of power equipment (actual "on-site" or net power). This difference is due to a variety of factors including, but not limited to, accessories (air cleaner, exhaust, charging, cooling, carburetor, fuel pump, etc.), application limitations, ambient operating conditions (temperature, humidity, altitude), and engine-to-engine variability. Due to manufacturing and capacity limitations, Briggs & Stratton may substitute an engine of higher rated power for this Series engine.

TRACTOR - - MODEL NO. TC 138 (96051012400), PRODUCT NO. 960 51 01-24
STEERING ASSEMBLY 41

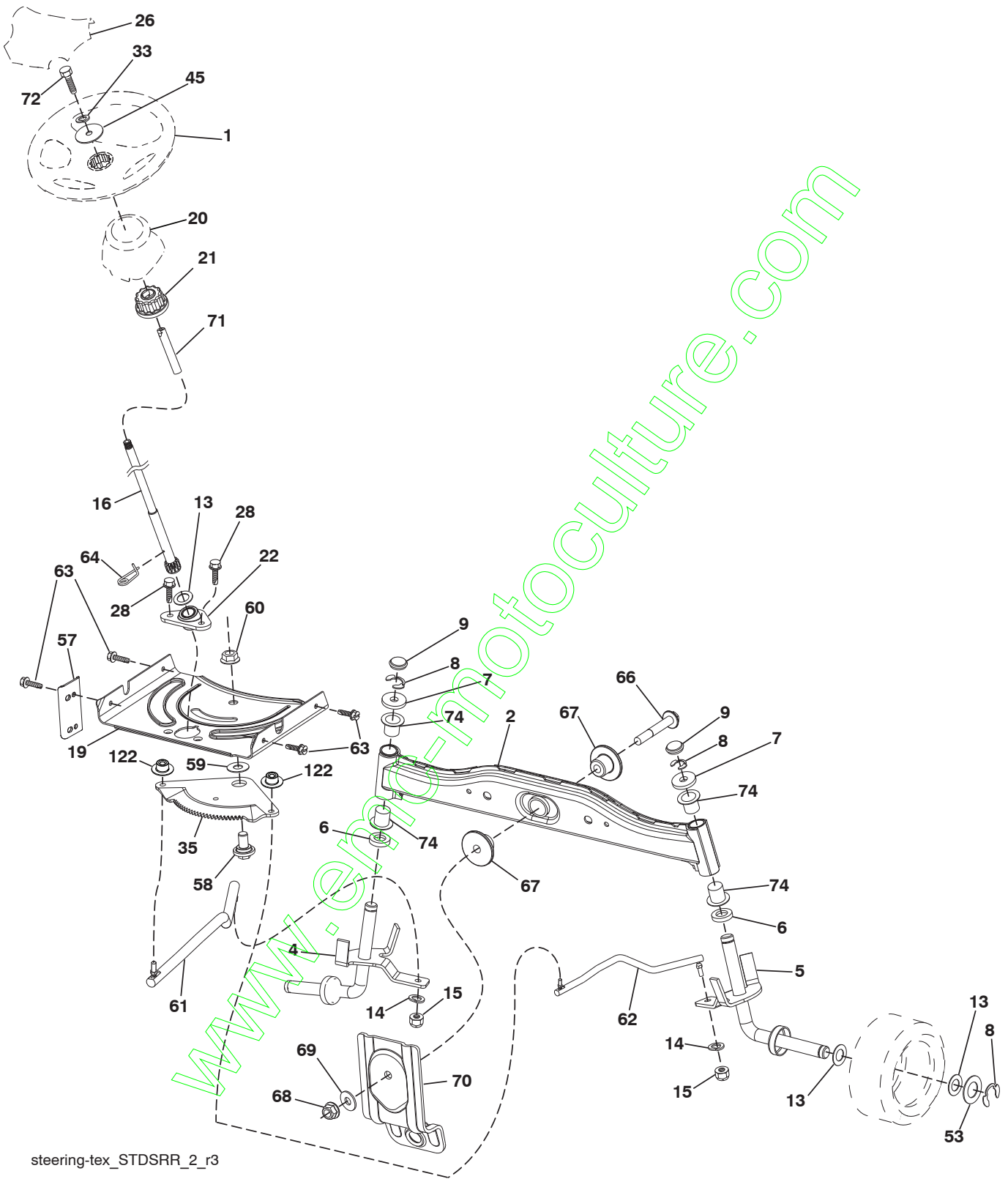

steering-tex_STDSRR_2_r3

**TRACTOR - - MODEL NO. TC 138 (96051012400), PRODUCT NO. 960 51 01-24
STEERING ASSEMBLY 41**

KEY NO.	PART NO.	DESCRIPTION
1	532 43 99-97	Wheel, Steering
2	532 41 81-68	Axle Asm.
4	532 40 30-87	Spindle Asm., LH
5	532 40 30-88	Spindle Asm., RH
6	532 12 49-31	Bearing, Race Thrust Harden
7	532 12 17-48	Washer 25/32 x 1-5/8 x 16 Ga.
8	812 00 00-29	Ring, Klip #T5304-75
9	532 12 12-32	Cap, Spindle
13	532 12 17-49	Washer 25/32 x 1-1/4 x 16 Ga.
14	810 04 06-00	Washer, Lock Hvy Hlcl Spr 3/8
15	873 54 06-00	Nut, Crown Lock 3/8-24 unf
16	532 42 93-73	Shaft Steering
19	532 19 47-29	Plate Steering
20	532 44 14-25	Boot, Steering
21	532 18 67-37	Adapter, Wheel Steering
22	532 42 05-37	Strg. Supt. Lower
26	532 43 97-43	Insert, Wheel Steering
28	817 00 06-12	Screw 3/8-16 x 3/4
33	810 04 05-00	Washer Lock 5/16
35	532 19 47-32	Gear, Sector Plate
45	819 11 38-12	Washer 11/32 x 3/8 x 12 Ga.
53	532 18 89-67	Washer Hardened .793 x 1.637 x .060
57	532 40 74-65	Bracket Upstop
58	532 19 47-47	Bolt Shoulder Sector Pivot CFM
59	532 19 47-48	Washer Thrust Sector Steering
60	873 97 10-00	Nut Flange Lock 5/8-11
61	532 19 47-40	Draglink, LH
62	532 19 47-41	Draglink, RH
63	817 00 05-12	Screw 5/16-18 x 3/4
64	532 19 98-49	Retainer Clip Spring Steering
66	871 02 07-48	Bolt Hex Fghd 7/16-14 x 3 Serr
67	532 19 47-37	Bushing PM Front Axle
68	873 90 07-00	Nut Lock Flange 7/16-14 Gr. 5
69	532 19 91-62	Washer 1.5 x .505 x .118
70	585 33 88-01	Bracket Deck Susp. Front
71	532 19 07-52	Shaft Extension Steering
72	532 42 89-82	Bolt Fin Hx 5/16-18 x 4
74	532 12 49-37	Bearing
122	532 44 49-62	Cap Gear Sector

NOTE: All component dimensions given in U.S. inches
1 inch = 25.4 mm

TRACTOR - - MODEL NO. TC 138 (96051012400), PRODUCT NO. 960 51 01-24
MOWER DECK 44

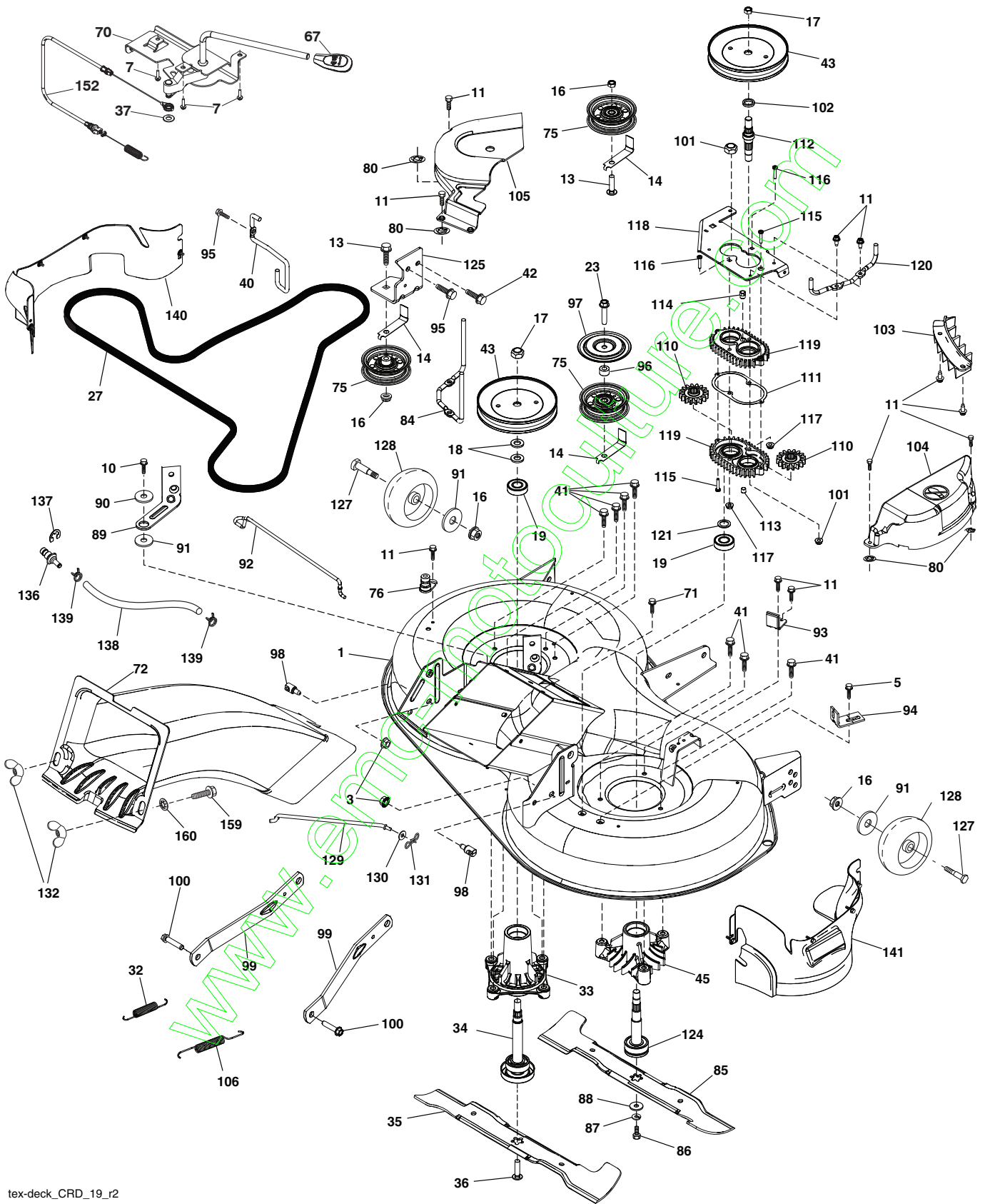

tex-deck_CRD_19_r2

**TRACTOR - - MODEL NO. TC 138 (96051012400), PRODUCT NO. 960 51 01-24
MOWER DECK 44**

KEY NO.	PART NO.	DESCRIPTION	KEY NO.	PART NO.	DESCRIPTION
1	532 44 09-71	Deck Weldment	100	532 19 65-39	Bolt Shoulder
3	873 90 05-00	Nut Lock Hex Flange 5/16 - 18	101	873 68 09-00	Nut Crownlock 9/16 - 18 unc
5	817 00 05-10	Bolt 5/16-18	102	532 40 25-11	Spacer Bearing Swing Plate
7	532 41 63-58	Screw #10 x 0.750 BOS Thread	103	532 43 69-92	Guard Front Vent
11	532 13 77-29	Screw Thd Roll 1/4 - 20 X 5/8	104	532 43 89-68	Mandrel Cover RH
13	872 11 06-12	Bolt Carr Sh 3/8 - 16 X 1-1/2 Gr. 5	105	532 43 87-44	Mandrel Cover LH
14	532 15 60-85	Keeper Belt Idler	106	532 19 32-16	Spring Brake Return
16	873 90 06-00	Nut Lock FIG 3/8 - 16 unc	110	532 41 53-56	Gear Output
17	532 40 02-34	Nut Flange Lock Top	111	532 43 69-79	Gasket Gearcase
18	532 18 76-90	Washer Spacer Mandrel	112	532 44 38-52	Shaft Gearcase Adapter
19	532 11 04-85	Bearing Ball Mandrel	113	532 43 85-33	Plug Oil
23	817 49 06-28	Screw Thdrol 3/8 - 16 X 1-3/4	114	532 43 85-34	Valve Relief
10	817 00 06-16	Screw 3/8-16x1 smgml tap	115	818 03 10-16	Screw Torx #10-24 x 1
27	532 43 97-26	V-Belt Drive	116	872 11 04-14	Bolt 1/4-20 x 1.75 Gr. 5
32	532 40 18-72	Spring Return Deck	117	873 90 04-00	Nut Hex Flange 1/4-20 unc
33	532 18 72-81	Housing Mandrel 4pt Service	118	532 43 69-89	Arm Clutching
34	532 19 28-72	Shaft Asm Mndrl N/Greaseable38	119	532 43 81-66	Gearcase Subasm
35	532 42 79-84	Blade Mower LH	120	532 43 69-91	Keeper Belt RH
36	532 19 30-03	Bolt/Washer Asm 7/16 - 20 unf	121	532 43 69-85	Washer
37	819 13 13-16	Washer 13/32 x 13/16 x 16 Ga.	124	532 43 69-86	Non Greasable Mandrel Shaft
40	532 19 72-58	Keeper Belt Engine LH	125	532 44 04-20	Bracket Idler Chassis
41	584 95 39-01	Bolt Hex	127	532 19 34-06	Bolt Shoulder 3/8-16 x 3-5/8 Gr. 5
42	817 00 05-12	Screw 5/16-18 x 3/4	128	532 17 48-73	Wheel Gauge
43	532 19 74-73	Pulley Mandrel	129	532 40 48-51	Rod Anti-Sway
45	532 13 71-52	Housing Mandrel	130	819 13 13-12	Washer 13/32 x 13/16 x 12 Ga.
67	532 40 30-12	Handle Clutch Cable	131	532 19 42-08	Pin Cotter 5/16 Bow Tie Lock
70	532 40 12-46	Clutch Asm Manual LT Pred	132	532 17 88-99	Knob Handle 3/8-16
71	817 67 06-08	Screw 3/8-16 x 1/2	136	532 43 96-39	Washout Port
72	532 44 68-10	Chute Upper	137	812 00 00-29	Ring Clip
75	532 13 14-94	Pulley Idler Flat	138	532 44 07-43	Hose
76	532 43 96-40	Washout Port	139	532 44 07-42	Hose Clamp
80	532 42 30-62	Pal Nut	140	532 44 86-32	LH Guard
84	532 43 25-20	Keeper Belt LH Mandrel	141	532 44 85-29	RH Guard
85	532 42 79-85	Blade Mower RH	152	532 44 04-88	Cable Clutch Manual w/Spring
86	532 18 17-13	Bolt 3/8-24 x 1.50 Gr. 8	159	872 14 06-14	Bolt 3/8-16 unc x 1-3/4
87	810 03 06-00	Washer Lock Hvy. 3/8	160	532 16 89-37	Nut Push
88	532 14 02-96	Washer Hard	--	532 19 28-70	Mandrel Assembly (Includes Housing Assembly (key#33), Shaft Assembly (key#34) and Bearing Only (key#19) - Pulley/ Nut/Washer And Blade Bolt/ Washers Not Included)
89	532 43 81-24	Arm Brake 97 LH	--	587 49 20-01	Replacement Mower Complete
90	532 19 90-92	Spacer Retainer			
91	819 13 20-12	Washer 13/32 x 1-1/4 x 12 Ga.			
92	532 43 69-93	Rod Brake Assembly			
93	532 43 81-25	Arm Brake RH			
94	532 19 72-50	Bracket Clutch Cable			
95	817 00 06-12	Screw 3/8-16 x 3/4			
96	532 40 02-71	Spacer			
97	532 18 20-61	Shield Idler Mower			
98	532 19 51-61	Stud Fastener			
99	532 19 51-86	Arm Suspension Mower Rear			

NOTE: All component dimensions given in U.S. inches
1 inch = 25.4 mm

**TRACTOR - - MODEL NO. TC 138 (96051012400), PRODUCT NO. 960 51 01-24
MOWER LIFT 45**

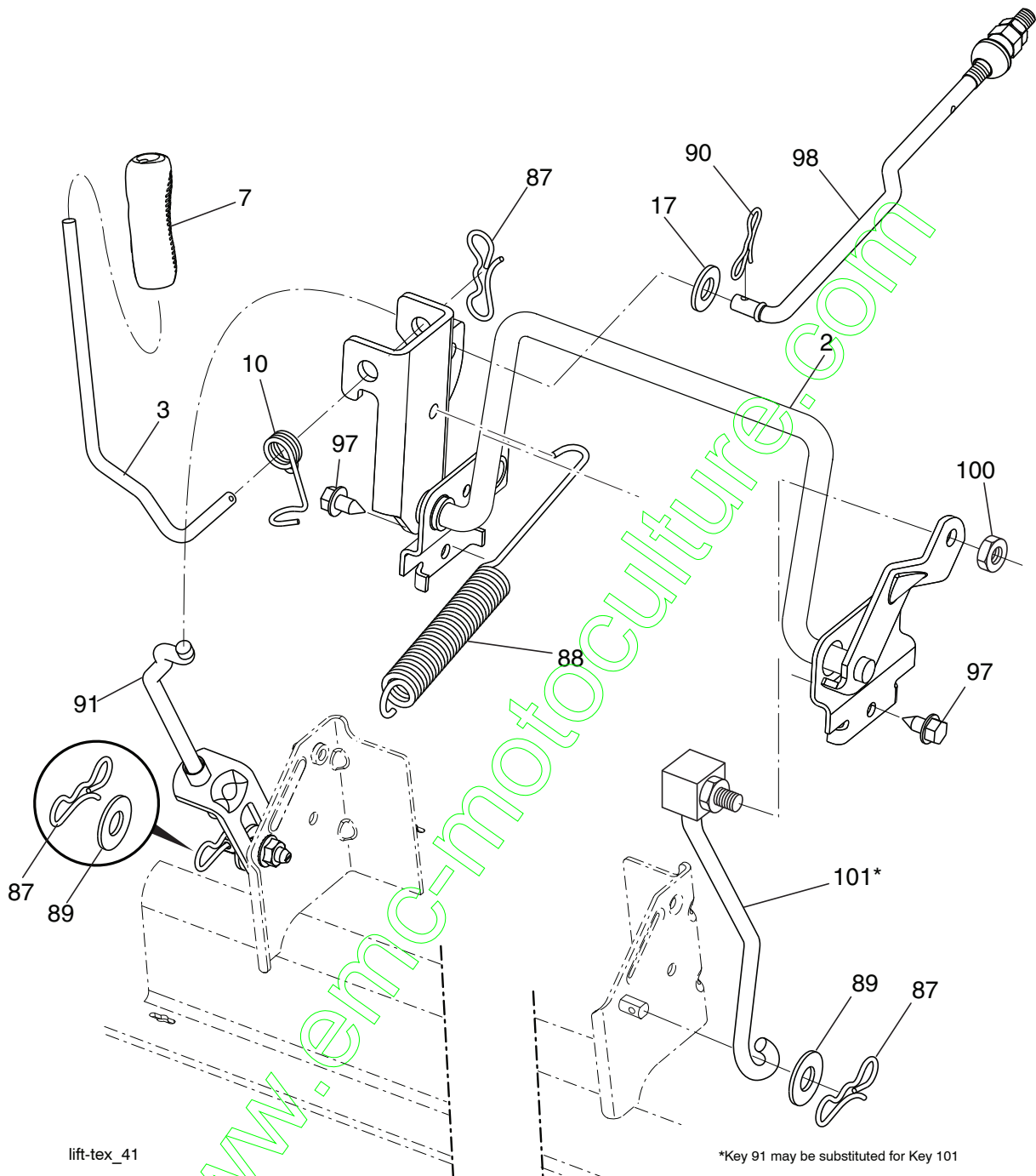

KEY NO. PART NO. DESCRIPTION

2	532 43 69-96	Deck Lift
3	532 19 52-31	Lever Asm., Lift RH
7	580 96 23-01	Grip, Lever
10	532 19 63-14	Spring Torsion
17	819 13 13-12	Washer 13/32 x 13/16 x 12 Ga.
87	532 19 42-09	Pin Cotter 7/16 Bow Tie Lock
88	532 44 54-96	Spring Lift Assist
89	819 19 19-12	Washer 17/32 x 1-3/16 x 12 Ga.
90	532 19 42-08	Pin Cotter 5/16 Bow Tie Lock

KEY NO. PART NO. DESCRIPTION

91	532 19 51-81	Link Lift Susp Mower Rear
97	817 49 06-08	Screw 3/8-16 x 1/2
98	532 19 52-70	Link Lift Susp. Front Mower
100	873 93 06-00	Nut Centerlock 3/8-16 unc
101	532 40 70-03	Link Asm. Lift Fixed

NOTE: All component dimensions given in U.S. inches
1 inch = 25.4 mm

**TRACTOR - - MODEL NO. TC 138 (96051012400), PRODUCT NO. 960 51 01-24
SEAT ASSEMBLY 42**

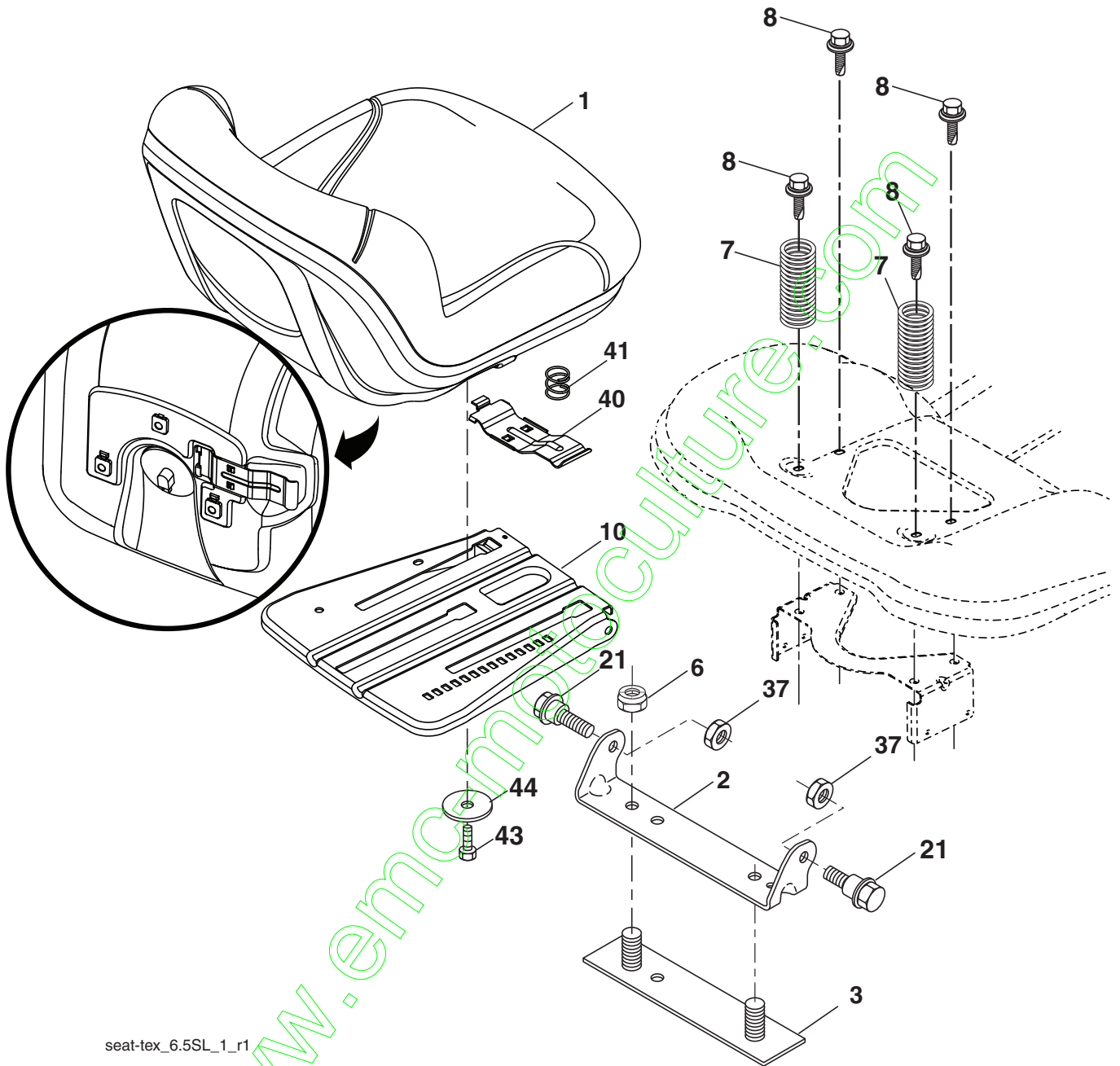

seat-tex_6.5SL_1_r1

KEY NO.	PART NO.	DESCRIPTION
1	532 43 97-09	Seat
2	532 18 01-66	Bracket Pivot Fender
3	532 14 06-75	Strap, Asm. Fender
6	873 80 06-00	Nut, Lock w/Ins. 3/8-16 unc
7	532 12 41-81	Spring, Seat Cprsn.
8	532 17 18-77	Bolt 5/16-18 unc x 3/4 w/Sems.
10	532 19 69-77	Pan, Seat
21	532 17 18-52	Bolt, Shoulder 5/16-18
37	873 80 05-00	Nut, Lock 5/16-18 unc

KEY NO.	PART NO.	DESCRIPTION
40	532 19 76-61	Handle
41	532 19 82-00	Spring
43	874 76 06-12	Bolt 3/8-16 unc x 3/4
44	819 13 38-12	Washer 13/32 x 2-3/8 x 12 Ga.

NOTE: All component dimensions given in U.S. inches
1 inch = 25.4 mm

TRACTOR - - MODEL NO. TC 138 (96051012400), PRODUCT NO. 960 51 01-24
BAGGER **46**

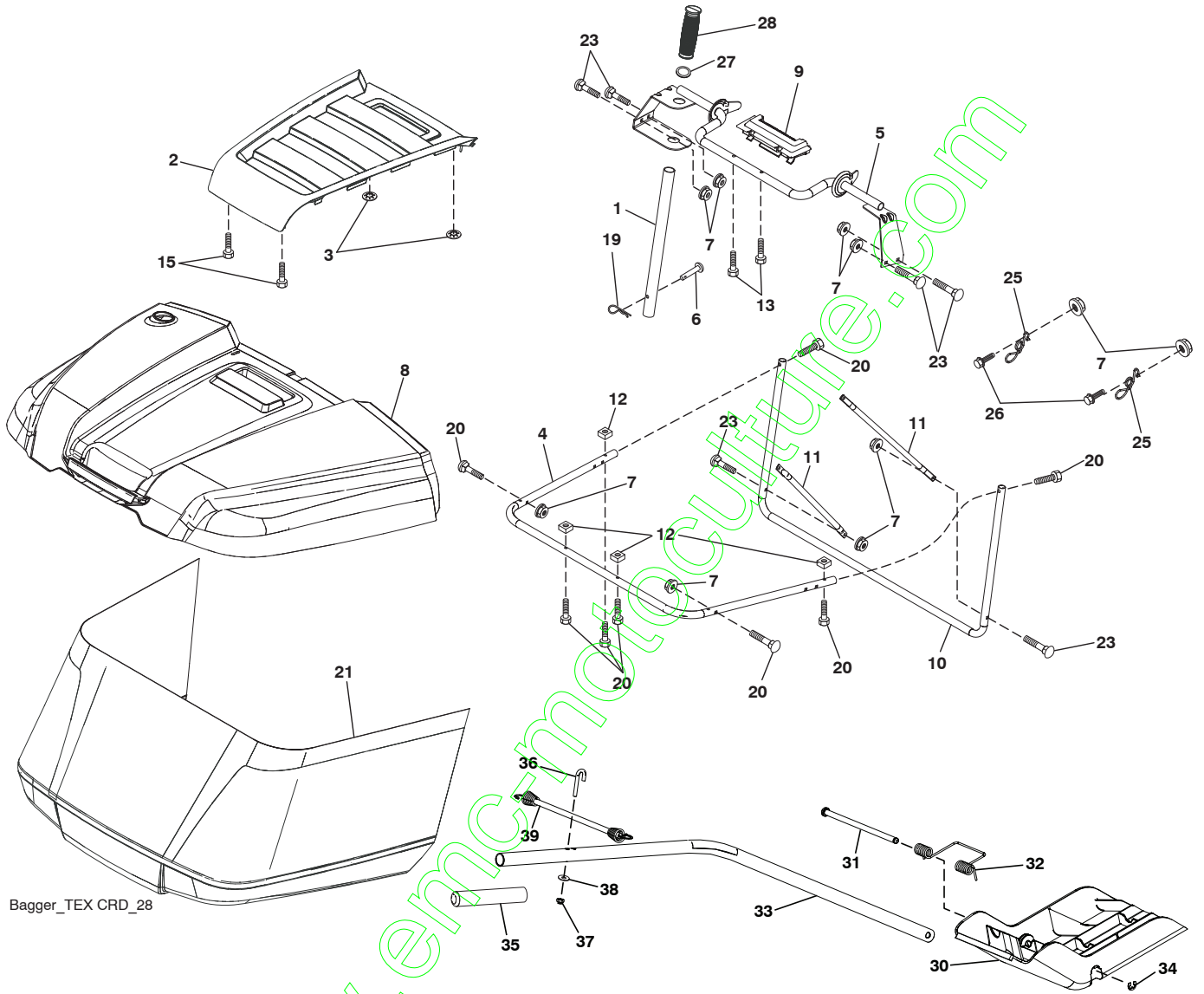

Bagger_TEX CRD_28

**TRACTOR - - MODEL NO. TC 138 (96051012400), PRODUCT NO. 960 51 01-24
BAGGER 46**

KEY NO.	PART NO.	DESCRIPTION
1	532 42 86-10	Tube Handle Bagger
2	532 44 13-58	Applique
3	532 41 38-08	Nut Push .156
4	532 43 96-12	Frame Asm Bagger Top
5	532 41 76-32	Frame Asm Top Bagger
6	532 12 68-75	Rivet Drilled
7	873 90 04-00	Nut Hex Flange 1/4-20 unc
8	532 44 12-61	Cover Bagger
9	532 41 76-29	Insert Handle Bagger
10	532 43 67-70	Frame Front
11	532 43 67-71	Tubing Brace Bagger
12	532 42 17-93	Nut Square 1/4
13	532 42 17-80	Screw 1/4 x 1.150
15	532 42 18-01	Screw #8 Dlat Head Drill Tip
19	532 19 42-08	Cotter Pin 5/16 Bow Tie
20	585 36 88-01	Screw Hex Cap 1/4-20 x 1.375
21	532 44 83-06	Bag Asm
23	872 04 04-10	Bolt Carr. 1/4-20
25	532 42 16-14	Spring Latch Bagger
26	817 49 04-12	Screw 1/4-20 x 3/4
27	532 42 12-62	Grommet Rubber
28	532 16 57-87	Grip Handle Black
30	532 43 74-52	Plug
31	532 43 58-61	Pin Hinge
32	532 43 74-54	Spring Double Torsion
33	532 43 84-51	Shaft Mulch Plug
34	532 43 79-88	E-Ring 5/16
35	532 43 91-39	Grip Mulch Plug
36	532 43 90-98	Bolt J
37	532 06 91-80	Nut Lock #10-24 unc
38	819 07 08-18	Washer 7/32 x 1/2
39	532 43 92-42	Bungee

NOTE: All component dimensions given in U.S. inches
1 inch = 25.4 mm

www.emc-motoculture.com