

TF 434

Spare parts
Pièces détachées

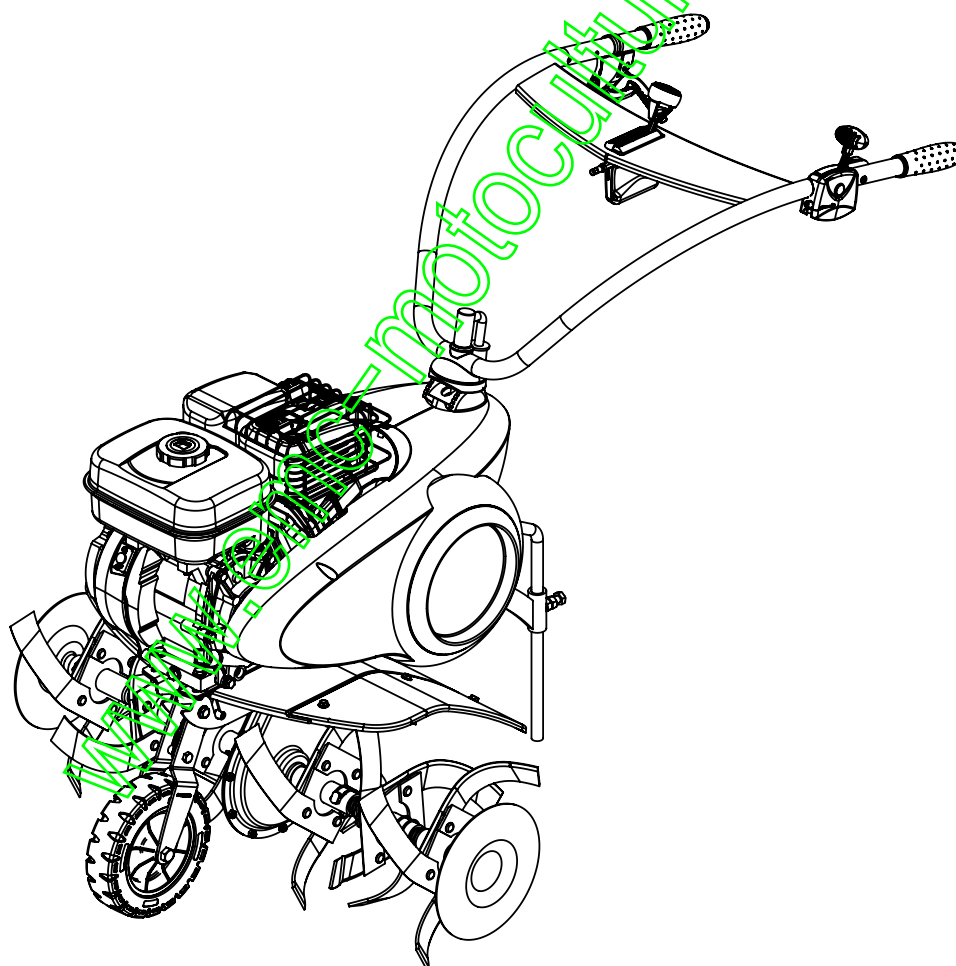

REPAIR PARTS

TILLER - MODEL NO. TF 434, PRODUCT NO. 966 78 69-01

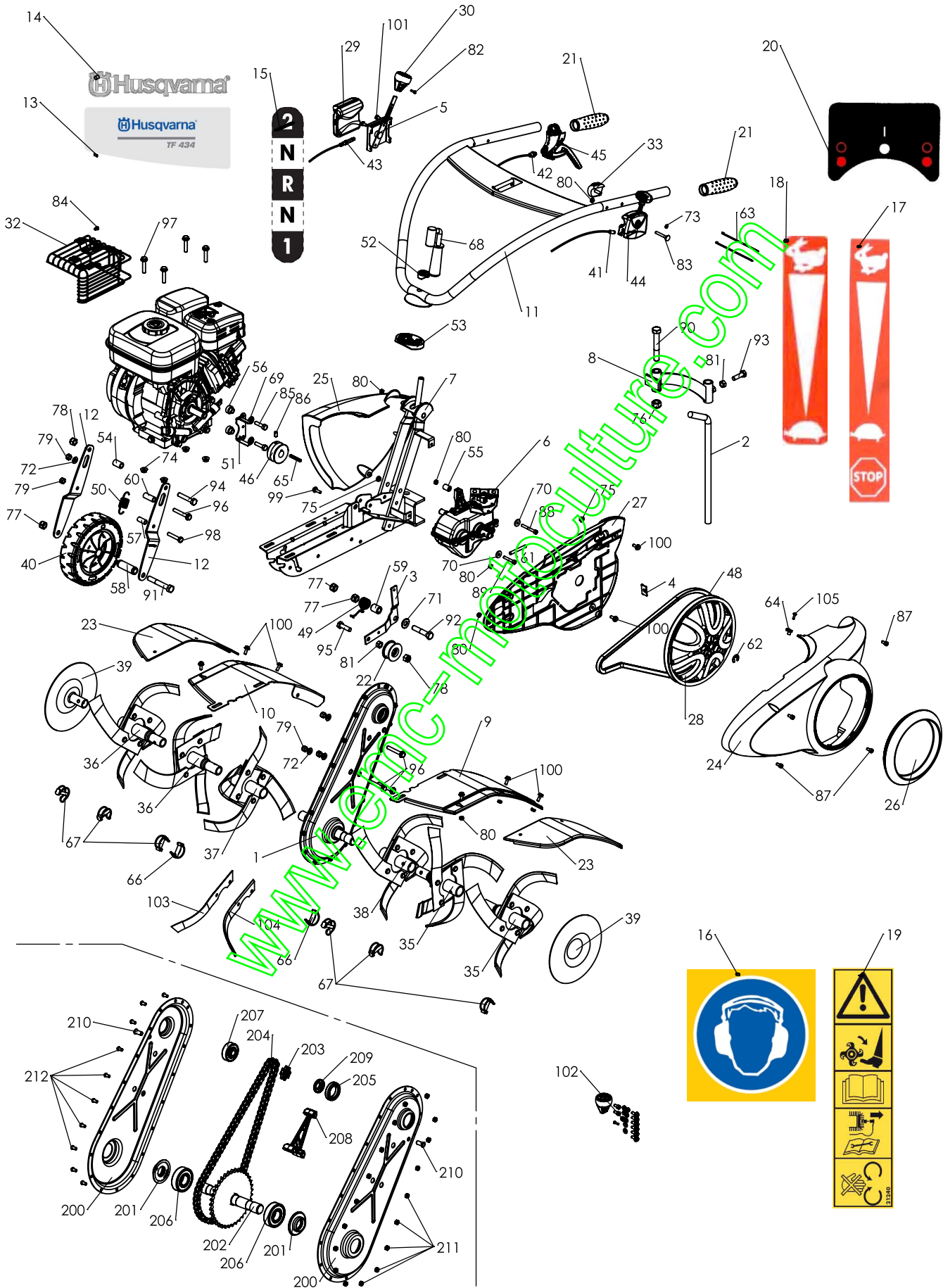

REPAIR PARTS

TILLER - MODEL NO. TF 434, PRODUCT NO. 966 78 69-01

Rep N°	Ref.	Ref	Description	Désignation	Qty
1	3001000050	580321001	Bolted transmission 8/37	CARTER 8/37 BOULONNE BV	1
2	3502010320	544 30 93 01	SPUR BLACK	BEQUILLE Ø16 xNOIRx	1
3	3002210201	580321501	PLATE FOR CLUTCH LEVER	LEVIER EMBR 98x117	1
4	3003210010	580322401	Snap in stop	BUTEE SNAP IN	1
5	3001000055	580321101	GEAR LEVER CONTROL	COMMANDE VITESSE F0603	1
6	3001000049	580320901	Gear box 2 front speed + 1 reverse speed	BOITE DE VITESSE F0603 BV2+1R BILLAGE	1
7	3002210607	580322101	M0701 FRAME GREY 627	CHASSIS M0701 GRIS 627	1
8	3002000322	580321401	Black adjustable spur support	CORPS EPERON REGL CINTRE NOIR	1
9	3002210604	580321901	M0701 TINE GUARD LEFT GREY HVA 627	AILE PROTECTION GAUCHE M0701 GRIS HVA 627	1
10	3002210603	580321801	M0701 TINE GUARD RIGHT GREY HVA 627	AILE PROTECTION DROITE M0701 GRIS HVA 627	1
11	3002210606	580322001	M0701 HANDLEBAR GREY HVA 627	Guidon M0701 GRIS HVA 627	1
12	3002210305	580321601	Wheel support black RAL 9005	PLATINE ROUE DE TRANSPORT NOIR RAL 9005	2
13	0503060023	580320701	STICKER TF434	ETIQUETTE TF 434	1
14	0503060022	580 32 06-01	STICKER HUSQVARNA	ETIQUETTE HUSQVARNA	1
15	0503010315	580320301	SPEED LABEL 2+N+R+N+1	STICKER VITESSE 2FN+R+N+1 F0603	1
16	0503000077	577 46 33-01	SAFY STICKER EARS PROTECTION	ETIQ. "SECURITE" 51x31 MM PROTECTION AUDITIVE	1
17	0503000045	519 64 66-80	STICKER THROTTLE CONTROL STOP-MIN-MAX	ETIQ. POIGNEE GAZ (AVEC STOP)	1
18	0503000043	531 00 82-51	Label throttle control without stop	ETIQ. GAZ (SS STOP) VERS PNEUM DIM 42X11	1
19	0503000036	531 00 85-40	STICKER SECURITY	"ETIQ. ""SECURITE 5 LOGOS""Xce	1
20	0503000031	501 96 37-01	STICKER SWITCH ON/OFF GX	"ETIQ. ""MARCHE/ARRET""/SWITCH DIM 20 X 15	1
21	0341000068	522 99 23-01	Rubber hand side grip	POIGNEE ELASTO D25 avec lèvre	2
22	0341000003	519 65 34-57	CLUTCH RUNNER BALL BEARING 6200 ZZ	GALET 2 EPAILLEMENTS ROUL 6200 ZZ	1
23	0340010136	580319601	GUARD EXTENSION LEFT & RIGHT ORANGE RAL 2009	ENSEMBLE EXT TOLE PROT M0701 ORANGE RAL 2009	1
24	0340010132	580319501	M0701 BELT COVER ORANGE RAL 2009	CAPOT COURROIE M0701 ORANGE RAL 2009	1
25	0340010131	580319401	M0701 RIGHT COVER ORANGE RAL 2009	CAPOT DROIT M0701 ORANGE RAL 2009	1
26	0340010112	580319201	M0701 DRESS UP HOLLOW DISK HVA GREY 627	DISQUE HABILLAGE CREUX M0701 GRIS HVA 627	1
27	0340010109	580319101	M0701 interior hide	CACHE INTERIEUR M0701 NOIR RAL9005	1
28	0340010105	580319001	TRANSMISSION PULLEY Ø206	POULIE Ø260 GRIS 7040	1
29	0340000012	580318801	GEAR CONTROL COVER	COQUE LEVIER DE VITESSE F0603	1
30	0340000011	580318701	SPEED SELECTOR LEVER	POMMEAU LEVIER DE VIT M0701	1
32	0330032001	531 00 85-82	EXHAUST GRILL EP	GRILLE ECHAPPEMENT EP	1
33	0330012006	531 00 85-58	Switch engine cut-off	SWITCH STOP GX	1
35	0320010008	531 00 85-22	LEFT ADDITIONAL TINE D25 HELICOID BLADE (40X4)	FRAISE ADDIT HEL 40X4 GAUCHE	2
36	0320010007	531 00 85-23	RIGHT ADDITIONAL TINE D25 HELICOID BLADE (40X4)	FRAISE ADDIT HEL 40X4 DROIT	2
37	0320010006	531 00 85-21	RIGHT TINE REMOVABLE D25 HELICOID BLADE (40X4)	FRAISE DEPART DEM HEL 40X4 DROIT	1
38	0320010005	531 00 85-20	LEFT TINE REMOVABLE D25 HELICOID BLADE (40X4)	FRAISE DEPART DEM HEL 40X4 GAUCHE	1
39	0320010001	519 65 33-62	DISK D25	DISQUE D25 PRIMO	2
40	0309000033	580318201	RT wheel Ø200 bore 20	ROUE RT DIAM200 ALS 20	1
41	0308040055	580317901	THROTTLE CABLE 1150 STROKE 60	CABLE GAZ x1150xLF60 Z0° MANETTE LGC	1
42	0308020052	577 46 37-01	CLUTCH CABLE LG1050 CF133 LAKS LEVER x CLIP TIP	CABLE EMB Lg 1050 CF 133 LAKS EMB CLIP	1
43	0308010012	580317401	Gear cable	CABLE VIT DOUBLE LG600 CF75	1
44	0307020023	577 45 30-01	THROTTLE LEVER LGC BLACK KNOB RAL9005	MANETTE GAZ LGC POMMEAU NOIR RAL9005	1
45	0307010034	577 54 87-01	HANDLEVER LAKS C27 D25 CLUTCHING SYMBOL	LEVIER EMB LAKS C27 GUID D25 TEMPO EMBRAYAGE	1
46	0306060005	544 24 39-01	ENGINE PULLEY D55 BORE Ø19,06	POULIE MOT D55 ALES 19,06	1
48	0306030057	580316401	BELT LA45	COURROIE LA45	1
49	0305020005	519 65 30-90	SPRING CP 21 25/10 GALVA LEVIER EMBR xMECA00x	RESSORT CP 21 25/10 GALVA LEVIER EMBR xMECA00	1
50	0305010015	580315701	Draw spring 43xØ20x22/10 galva	RESSORT TR 43xØ20x22/10 GALVA	1
51	0304000303	580 31 56-01	DRIVE BELT ENGINE PULLEY	GUIDE COURROIE Ø55 carter 8/37	1
52	0303000024	580315201	Tightening lever spacer height 16	ENTRETOISE POIGNEE SERRAGE H16	1
53	0303000023	580315101	M0701 filler piece	RONDELLE CRANTE M0701 LIAISON GUIDON	1
54	0302020116	580315001	SPACER 16x10x26 xZ	ENTR. 16x10x26 xZNCR3x	1
55	0302020112	580314801	SPACER 14x6x18.4 xZ	ENTR. 14x6x18.4xZ	1
56	0302020111	580314701	SPACER SHOULDER 13x9x16.5 Z	ENTRET EPAUL D13 d9 Lg16,5	2
57	0302020103	577 52 03-01	SPACER 12x8x26 Z	ENTR. 12x8x26 Z	1
58	0302020081	575 36 08-01	PLASTIC SPACER 20x12.5x61.5	ENTR. 20X12.5x61.5 xPOM	1
59	0302020020	575 36 05-01	Clutch lever spacer	ENTRET. LEV EMB xMECAx PA6,6 12x20 LG 24	1
60	0302020015	575 36 10-01	SPACER 14x9x35 xZ	ENTR. 14x9x35 xZNCR3x ENTRETOISE CHASSIS	1
61	0302010021	519 65 30-67	PULLEY PIN SHAFT MECANIQUE	AXE FIXATION POULIE INVERSEUR MECANIQUE	1
62	0301070026	580314201	RADIAL RETAINING RING Ø12	ANNEAU ELASTIQUE RADIAL DIAM12 DIN6799	1
63	0301060003	544 31 11-01	COLLAR	COLLIER POLYAM.3.6 X 140 NOIR	2
64	0301050003	580314101	EASYBOSS CLIP 40X25X7	CLIP EASYBOSS 40X25X7	1
65	0301040001	519 65 30-21	KEY 4.76X4.76X40 DRO TOL h 9 - XC 48	CLAVETTE 4.76X4.76X 40 BTS DRO TOL h 9 - XC 48	1
66	0301010014	577 45 36-01	CLIP PIN D10 x 36	GOUPILLE CLIPS 10 x 36	2
67	0301010013	577 45 35-01	CLIP PIN D8 x 36	GOUPILLE CLIPS 8 x 36	6
68	0300801401	531 00 82-37	HANDLEBAR TIGHTENING LEVER	POIGNEE SERRAGE M14x150 EMBOUT NOIR	1
69	0300430801	544 31 49-01	CONTACT WASHER 8	RONDELLE CONTACT M8 NF E 25511	2
70	0300410602	531 00 83-90	SPECIAL WASHER 6,3 x 19 x 2,5Z	RONDELLE SPECIALE 6,3X19 X2,5Z	2
71	0300401201	519 65 34-53	PLATE WASHER M 12X27X2.5 Z NFE 25513	RONDELLE PLATE M 12X27X2.5 Z NFE 25513	1
72	0300400802	544 20 81-01	PLATE WASHER M 8X18X1.5 Z NFE 25513	RONDELLE PLATE M 8X18X1.5 Z NFE 25513	4
73	0300400301	531 00 85-39	Washer M 3.2x10x1 Z	RONDELLE PLATE 3.2x10x1 Z	1
74	0300260801	519 65 34-30	NUT H M8 Z NOTCHED SHOULDER	ECROU HM 8 ZEMB CR DIN 6923-8	4
75	0300260601	519 65 34-32	NUT H M6 Z NOTCHED SHOULDER	ECROU HM 6 ZEMB CR DIN 6923	3
76	0300211402	531 00 85-78	Blocking nut M 14 Z DIN 985-8	ECROU FREIN M14 Z DIN 985-8	1
77	0300211201	752 25 50-51	BLOCKING NUT M 12 Z	ECROU FREIN M 12 Z DIN 985/8	3
78	0300211001	519 65 34-58	BLOCKING NUT M 10 Z	ECROU FREIN M 10 Z DIN 985/8	2
79	0300210802	544 20 79-01	BLOCKING NUT HM 8 Z DIN 985/8	ECROU FREIN M 8 Z DIN 985/8	5
80	0300210602	732 26 16-01	BLOCKING NUT M 6 Z	ECROU FREIN M 6 Z DIN 985-8	12
81	0300201002	519 65 34-56	NUT HM 10Z	ECROU H.U. M 10 Z DIN 934	2
82	0300120404	580313801	Screw PT WN 1412 KB 40x14	VIS PT WN 1412 KB40x14 Z CRUCI	1
83	0300080610	577 45 38-01	SCREW TRCC 6 X 45 Z	VIS TRCC 6 X 45/20 Z Din603	1

REPAIR PARTS

TILLER - MODEL NO. TF 434, PRODUCT NO. 966 78 69-01

Rep N°	Ref.	Ref	Description	Désignation	Qty
84	0300080404	576 14 52-01	SHEET SCREW TCB 4.8 X 9.5	VIS TOLE TCB 4.8X9.5 DIN 7981	1
85	0300060502	531 00 85-86	SCREW 5/16 TH 24 UNF LG 32	VIS 5/16 TH 24 UNF LONG 32 Z	2
86	0300040801	728 69 23-00	SCREW ST HC M8X16 DIN 914 45H	VIS STHC 8 X 16 N BT POINTU DIN 914 45H	1
87	0300020608	580 31 35-01	Screw CHC M6x12z	VIS CHC 6 X 12 Z DIN 912 8.8	4
88	0300020605	519 65 30-10	SCREW CHC 6 X 50 Z DIN 912 8.8	VIS CHC 6 X 50 Z DIN 912 8.8	1
89	0300020604	580407801	Screw CHC M6x35z	VIS CHC 6 X 35 Z DIN 912 8.8	1
90	0300011401	531 00 82-20	Screw H M14x90-34 z cl 8.8 NFE 24014 - ISO 4014	VIS H 14 X 90/34 Z CL 8.8 NFE 24014 - ISO 4014	1
91	0300011206	519 65 31-31	SCREW H M 12X80/30 Z ISO4014	VIS H M 12x80/30 Z ISO 4014 CL 6.8	1
92	0300011205	575 36 18-01	Screw H M12 x 60 z	VIS H 12 X 60/30 N DIN931/6.8	1
93	0300011015	544 20 77-01	Screw HM 10x30z FST	VIS HM10 X 30 Z NFEN24017 CL8.8 FST	1
94	0300011007	519 65 30-46	Screw H M 10x55 Z	VIS H M 10x55/26 Z ISO 4014 cl 6.8	1
95	0300011003	519 65 34-55	SCREW HM 10X35Z FST	VIS H 10 X 35 FST Z NFEN 24017	1
96	0300010837	575 36 16-01	SCREW H 8x55 Z DIN 6921 NOTCHED SHOULDER CL 6.8	VIS H 8x55 Z EMB CR DIN 6921 CL 6.8 FILETAGE PARTIEL	4
97	0300010817	519 65 34-13	SCREW H M8 X 40	VIS H 8x40 Z EMB CR DIN 6921	4
98	0300010802	580313401	Screw H M8 x 45	VIS H 8 X 45/22 Z (DIN)931/6.8	1
99	0300010610	576 14 54-01	Screw HM 6x20 notched shoulder	VIS H 6x20 Z EMB CR DIN 6921	1
100	0300010609	519 65 34-35	SCREW HM 6X16 Z NOTCHED SHOULDER	VIS H 6x16 Z EMB CR DIN 6921	8
101	0300010608	519 65 31-14	Screw HM6x12	VIS H 6 X 12 Z NFE EN 24017/6.8	2
102	0300000036	580 49 29-01	POCHETTE VISSERIE M0701	POCHETTE VISSERIE M0701	1
103	0001000030	531 00 85-47	Left spiral blade	COUTEAU HEL 40X4 GAUCHE	1
104	0001000029	531 00 85-48	Right spiral blade	COUTEAU HEL 40X4 DROIT	1
105	0300120401	522 99 54-01	Screw WN 1451 K 40x14 Trox	VIS PT WN 1451 K40x14 Z	1
200	3002210308	580321701	Transmission housing 8/37 black RAL 9005	JOIE DE CARTER 8/37 NOIR RAL 9005	2
201	0341000059	531 00 85-76	Seal	Joint Carter 1/5 Ø62 x Ø25	2
202	0306050045	580317001	Blade shaft 37 teeth 12.7	ARBRE DE TRAVAIL 37DTS 12.7	1
203	0306050016	519 65 30-57	PIGNON 8 TOOTH 12.7 RIBBED	PIGNON 8 DTS 12.7 SIMPLE cannelé	1
204	0306020026	580 31 63-01	CHAIN (78 LINKS RSF) 08B 12.7	CHAINE ISO 08B-1 pas 12.7 78 maillons RSF	1
205	0306010037	580315901	Ball bearing 6906 2RS	ROULEMENT 6906 2RS	1
206	0306010020	519 65 30-53	BALL BEARING 6305 2RS	ROULEMENT 6305 2 RS cl: 0	2
207	0306010016	531 00 85-46	SPECIAL BALL BEARING 6204 2RS	ROULEMENT 6204 2RS EPAULE	1
208	0303000029	580315401	TRANSMISSION SPACER 8/37	ENTRETOISE 3 pts CARTER 8/37	1
209	0303000026	580315301	Transmission spacer	ENTRETOISE 34.5x16x9 CARTER 8/37	1
210	0300600604	580313901	Insert M6	INSERT M6 ROND BORGNE TOLE 1.5/3	2
211	0300210602	732 26 16-01	BLOCKING NUT M 6 Z	ECROU FREIN M 6 Z DIN 985-8	18
212	0300110604	580313701	Screw Torx M6x12	VIS TORX M6X12 TETE CYLIND BOMB 6 LOBES INTER	18

www.emc-motocultures.com

REPAIR PARTS

TILLER - MODEL NO. TF 434, PRODUCT NO. 966 78 69-01

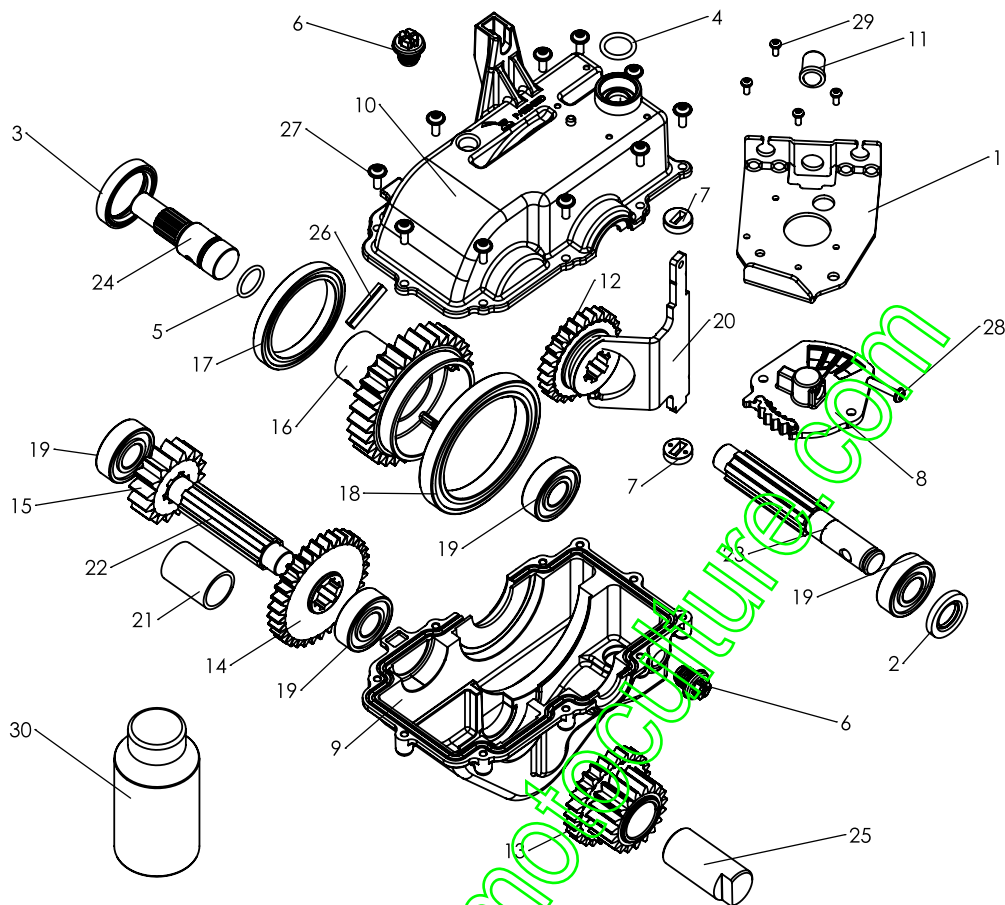

Rep N°	Ref.	Ref	Description	Désignation	Qty
1	3003210011	580322501	SPEED SELECTION CABLE PLATE	PLATINE ACCROCHE CABLE VITESSE F0603	1
2	0343020003	580320101	SEALING WASHER 15x28x4	BAGUE D'ETANCHEITE 15x28x4 IEL AI DL	1
3	0343020002	580320001	Sealing washer 30x40x7	Bague d'étanchéité 30x40x7 IEL AI DL	1
4	0343010005	580319901	O'RING SEAL Ø15x2.5	JOINT TORIQUE Ø15x2.5	1
5	0343010004	580319801	O'RING SEAL Ø16x2	JOINT TORIQUE Ø16x2	1
6	0341000093	580319701	CAP M12x1.5	BOUCHON M12x1.5	2
7	0340000010	580318601	FORK GUIDE F0603	ENTRETOISE GUIDE FOURCHETTE F0603	2
8	0340000009	580318501	SPEED SELECTOR LEVER	LEVIER SELECTION DE VITESSE F0603	1
9	0340000008	580318401	BOTTOM CARTER F0603	COQUE INFERIEUR F0603	1
10	0340000007	580318301	UPPER CARTER F0603	COQUE SUPERIEUR F0603	1
11	0307000003	580317101	BALL RUSHER SPRING Ø10	POUSOIR A RESSORT BILLE Ø10	1
12	0306050044	580316901	SELECTION GEAR 26th M2	PIGNON BALADEUR 26 dts M2	1
13	0306050043	580316801	REVERSE GEAR 19-27 th M2	PIGNON MAR 19 et 27 dts M2	1
14	0306050042	580316701	1ST GEAR 33 th M2	PIGNON 1er 33 dts M2	1
15	0306050041	580 31 66-01	INTERMEDIATE GEAR 16 th M2.5	PIGNON INTER 16 dts M2.5	1
16	0306050040	580316501	OUTPUT GEAR 31 th M2.5	PIGNON SORTIE BOITE 31dts M2.5	1
17	0306010040	580 31 62-01	BALL BEARING 6810	ROULEMENT 6810	1
18	0306010039	580 31 61-01	BALL BEARING 6813	ROULEMENT 6813	1
19	0306010038	580316001	Ball bearing 6202	Roulement 6202	4
20	0304000299	580315501	SELECTION FORK F0603	FOURCHETTE SELECTION VITESSE F0603	1
21	0302020113	580314901	SPACER 20x24x33	ENTRETOISE 20x24x33	1
22	0302010111	580314601	SECONDARY SHAFT F0603	ARBRE SECONDAIRE F0603	1
23	0302010110	580314501	INPUT SHAFT F0603	ARBRE D'ENTREE F0603	1
24	0302010109	580314401	OUTPUT SHAFT F0603	ARBRE DE SORTIE F0603	1
25	0302010108	580314301	THIRD SHAFT F0603	ARBRE TERTIAIRE MAR/1ER F0603	1
26	0301020018	580314001	Cotter-pin 6x28	Goupille HBK 6x28 DIN 8748 ST	1
27	0300090405	580313601	Screw Altracs WN5151 40x12z	Vis Altracs WN5151 40x12z Ejet: 6317036809	10
28	0300090403	531 00 94-49	Screw WN 1452 K40x20 Torx	VIS TORX WN 1452 K40x20	1
29	0300090303	522 99 55-01	Screw WN5251 K30x8z	Vis altracs WN5251 K30x8z	4
30	0102000020	580313301	Oil EP SAE 80W90	BIDON D'HUILE 2L EP SAE 80W90	1

www.emc-motoculture.com