

[www.emc-motoculture.com](http://www.emc-motoculture.com)

**TCP**  
**TC**  
**TCP**

hydro  
hydro

**CATALOGO PEZZI DI RICAMBIO**  
**SPARE PARTS CATALOGUE**  
**CATALOGUE DE PIECES**  
**ERSATZTEILKATALOG**

**1999**

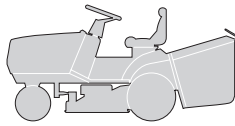

**COME USARE IL CATALOGO**

**1. Generalità**

Questo catalogo contiene tutte le informazioni necessarie per ordinare correttamente i pezzi di ricambio.

**2. Struttura del catalogo**

In ogni pagina del catalogo sono riportate le seguenti indicazioni:

**HOW TO USE THE CATALOGUE**

**1. General information**

This catalogue contains all the information necessary for correctly ordering spare parts.

**2. Structure of the catalogue**

Each page of the catalogue has these indications:

**COMMENT UTILISER LE CATALOGUE**

**1. Généralités**

Ce catalogue contient toutes les indications nécessaires pour commander correctement les pièces détachées.

**2. Structure du catalogue**

Les indications suivantes sont reportées sur chaque page du catalogue:

**WIE IST DER KATALOG ZU BENUTZEN**

**1. Allgemeines**

Dieser Katalog enthält alle Informationen, die für die korrekte Bestellung von Ersatzteilen erforderlich sind.

**2. Aufbau des Katalogs**

Auf jeder Seite des Katalogs sind die folgenden Angaben wiedergegeben:

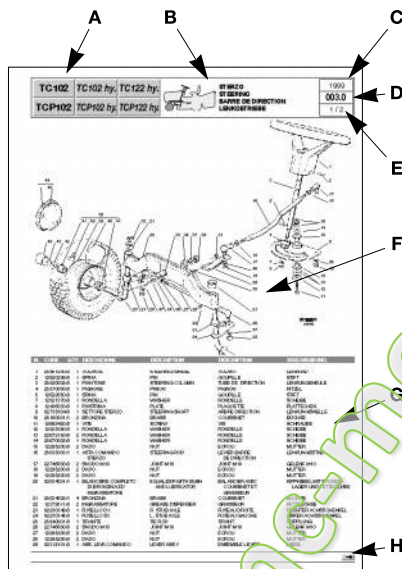

**A.** Macchina o serie di macchine per le quali la pagina è valida.

**B.** Indicazione del gruppo con la raffigurazione in miniatura della sua collocazione sulla macchina.

**C.** Anno di produzione della macchina a cui si riferisce.

**D.** Numerazione progressiva della tavola, secondo il seguente criterio:  
 - le prime due cifre indicano il numero progressivo;  
 - le eventuali lettere che seguono indicano le diverse versioni alternative di quel gruppo;  
 - la cifra dopo il punto indica un eventuale aggiornamento nel corso della annualità indicata al punto 3.

**A.** Machine or machine series to which the page applies.

**B.** Indication of the unit with a miniature drawing showing its position on the machine.

**C.** Year of production of the machine concerned.

**D.** Progressive numbering of the table, arranged as follows:  
 - the first two numbers are the progressive number;  
 - any letters that follow will indicate the various alternative versions of that unit;  
 - the number after the dot is for any updates during the year given at point 3.

**A.** La machine ou la série de machines auxquelles se réfère la page.

**B.** L'indication du groupe avec la représentation en miniature de sa position sur la machine.

**C.** L'année de fabrication de la machine concernée.

**D.** La numérotation progressive du tableau, selon le critère suivant:  
 - les deux premiers chiffres indiquent le numéro progressif;  
 - les éventuelles lettres qui suivent indiquent les différentes versions alternatives de ce groupe;  
 - le chiffre après le point indique l'éventuelle mise à jour effectuée au cours de l'année indiquée au point 3.

**A.** Maschine oder Serie der Maschine, für welche die Seite gültig ist.

**B.** Bezeichnung der Gruppe mit einer Miniaturdarstellung ihrer Anbringung auf der Maschine.

**C.** Herstellungsjahr der betreffenden Maschine.

**D.** Progressive Numerierung der Tafel nach folgendem Kriterium:  
 - die ersten zwei Ziffern bezeichnen die progressive Nummer;  
 - die eventuellen Buchstaben, die folgen, bezeichnen die verschiedenen alternativen Versionen dieser Gruppe;  
 - die Ziffer nach dem Punkt bezeichnet einen eventuellen neueren Stand im Laufe des Jahrgangs, der in Punkt 3 angegeben ist.

Esempio:

**005a.0 =**

005 Gruppo Motore  
 a 16 - 18 HP B&S  
 .0 Prima stesura

Example:

**005a.0 =**

005 Engine unit  
 a 16 - 18 HP B&S  
 .0 First copy

Exemple

**005a.0 =**

005 Groupe Moteur  
 a 16 - 18 HP B&S  
 .0 Première rédaction

Beispiel:

**005a.0 =**

005 Motorgruppe  
 a 16 - 18 HP B&S  
 .0 Erste Ausgabe



**E.** Numero della pagina e numero totale delle pagine necessarie per la descrizione del gruppo.

**E.** Page number and total number of pages necessary for the description of the unit.

**E.** Numéro de la page et nombre total des pages nécessaires pour la description du groupe.

**E.** Seitenzahl und Gesamtzahl der Seiten, die für die Beschreibung der Gruppe erforderlich sind.

**F.** Vista esplosa del gruppo.

**F.** Exploded view of the unit.

**F.** Vue éclatée du groupe.

**F.** Explosionszeichnung der Gruppe.

**G.** Descrizione completa dei singoli particolari, con codice e quantità di pezzi.

**G.** Full description of each part, with code number and number of pieces.

**G.** Description complète de chaque élément, avec code et quantité des pièces.

**G.** Vollständige Beschreibung der Einzelteile, mit Kodenummer und Menge der Teile.

**H.** Indicazione della presenza di altre pagine di seguito.

**H.** Indication of additional pages.

**H.** Indication de la présence d'autres pages successives.

**H.** Angabe über die Präsenz weiterer folgender Seiten.

Nelle pagine di seguito, sono riportate nuovamente le indicazioni relative ai punti A - C - D - E - G e H.

The additional pages repeat the indications as at points A - C - D - E - G and H.

Les pages qui suivent reportent, elles aussi, les indications concernant les points A - C - D - E - G et H.

Auf den nachfolgenden Seiten sind die Bezeichnungen, die sich auf die Punkte A - C - D - E - G und H beziehen, erneut wiedergegeben.

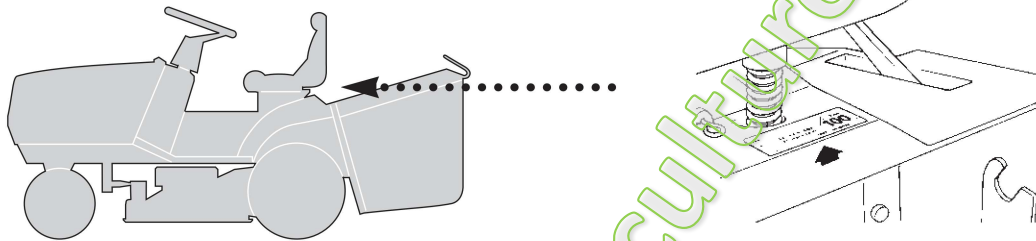

**3. Ordine di ricambi**

**3. Spare parts order**

**3. Commande pièces détachées**

**3. Ersatzteilbestellungen**

Prima di formulare un ordine di ricambi, accertare che il catalogo corrisponda all'anno di costruzione della macchina, e riportato sulla targhetta di identificazione.

Before putting in an order for spare parts, make sure that the catalogue is the one applying to the machine's year of manufacture, as shown on the identification plate attached to the machine.

Avant de passer une commande pour des pièces détachées, s'assurer que le catalogue est celui correspondant à l'année de fabrication de la machine reportée sur la plaquette d'identification.

Ehe eine Ersatzteilbestellung geschrieben wird, muß man sich vergewissern, daß der Katalog mit dem Herstellungsjahr der Maschine übereinstimmt, oder mit dem auf dem Kennzeichenschild wiedergegeben.

Ogni ordine di ricambi deve necessariamente contenere:

Each spare parts order must include:

Chaque commande de pièces détachées doit obligatoirement contenir:

Jede Ersatzteilbestellung muß enthalten:

- modello della macchina;
- quantità di pezzi richiesta;
- descrizione (eventuale);
- numero di codice del pezzo;
- destinatario
- mezzo di spedizione.

- the model of the machine;
- the number of parts required;
- description (if any);
- the code number for the item;
- the destination;
- the method of shipping.

- modèle de la machine;
- quantité de pièces demandée;
- description (éventuelle);
- numéro de code de la pièce;
- le destinataire;
- le moyen de transport.

- Modell der Maschine;
- Menge der angeforderten Teile;
- Bezeichnung (eventuell);
- Artikelnummer des Teils;
- Empfänger;
- Versandart.

**Esempio di ordinazione:**

**An example of an order:**

**Exemple de commande:**

**Beispiel einer Bestellung:**

Su una macchina TCP122 hy. del 1999, con motore B&S da 18 HP si deve sostituire il silenziatore di scarico. Tale particolare è raffigurato nella tavola 005a.0 alla posizione 21, a cui corrisponde il codice 18716131/1.

The exhaust pipe silencer on a TCP122 hy. machine, produced in 1999 with an B&S 18 HP engine, must be replaced. This part is shown in table 005a.0 in position 21, and has the code number 18716131/1.

Sur une machine TCP122 hy. du 1999, avec moteur B&S de 18 CH, il faut remplacer le silencieux d'échappement. Cette pièce est représentée sur le tableau 005a.0 à la position 21, correspondant au code 18716131/1.

Auf einer Maschine TCP122 hy. von 1999, mit Motor B&S mit 18 PS muß der Auspufftopf ersetzt werden. Dieses Einzelteil ist auf der Tafel 005a.0 unter der Position 16 dargestellt, der dem Code 18716131/1 entspricht.

L'ordinazione sarà quindi:

The order will therefore be:

La commande sera donc formulée de la façon suivante:

Die Bestellung lautet demnach:

per TCP122 hy.:  
n. 1 silenziatore cod. 18716131/1  
da inviare a .....  
a mezzo .....

for TCP122 hy.:  
1 silencer - code 18716131/1  
to be sent to .....  
method of shipping .....

pour TCP122 hy.:  
1 silencieux - code 18716131/1  
à envoyer à .....  
par .....

Für TCP122 hy.:  
1 Auspuff - Kode 18716131/1  
zu versenden an .....  
mit .....

**Nota**

**Note**

**Remarque**

**Anmerkung**

Per le parti non codificate del motore e della trasmissione contrassegnate con (\*), occorre rivolgersi al Costruttore.

For parts of the engine and the transmission without code numbers, marked by (\*), it's necessary to contact the manufacturer.

Pour les pièces non codées du moteur et de la transmission, indiquées avec (\*), il faut s'adresser au Fabricant.



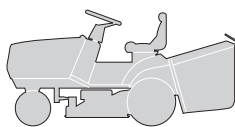

Für die nicht codierten Teile des Motors und des Antriebs, die mit (\*) gekennzeichnet sind, muß man sich an den Hersteller wenden.

<b>TC102</b>	<b>TC102 hy.</b>	<b>TC122 hy.</b>
<b>TCP102</b>	<b>TCP102 hy.</b>	<b>TCP122 hy.</b>

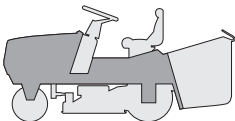
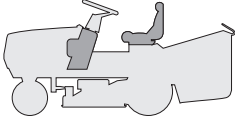

**INDICE DELLE TAVOLE**  
**INDEX OF TABLES**  
**SOMMAIRE DES TABLEAUX**  
**INHALT DER TAFELN**

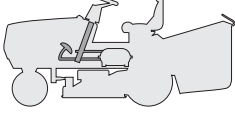
1999
<b>000.0</b>
3 / 8

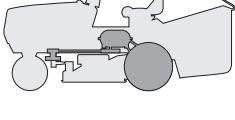
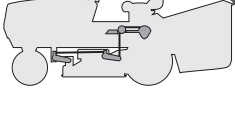
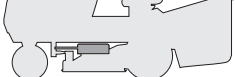
GRUPPO / UNIT / GROUPE / GRUPPE	TC102	TCP102	TC102 hydro	TCP102 hydro	TC122 hydro	TCP122 hydro
 CARROZZERIA E CHASSIS BODY AND CHASSIS CARROSSERIE ET CHASSIS KARROSSERIE UND GEHÄUSE .....	001	001	001	001	001	001
 CRUSCOTTO E SEDILE DASHBOARD AND SEAT TABLEAU COMMANDES ET SIEGE KONSOLE UND SITZ .....	002	002	002	002	002	002
 STERZO STEERING BARRE DE DIRECTION LENKGETRIEBE .....	003	003	003	003	003	003
 COMANDO FRENO E COMANDO CAMBIO BRAKE AND GEARBOX CONTROLS COMMANDE FREIN ET BOITE DE VITESSE BREMSE UND WECHSEL ANTRIEB .....	004M	004M	-	-	-	-
 COMANDO TRASMISSIONE E FRENO DRIVE AND BRAKE CONTROLS COMMANDE TRANSMISSION ET FREIN GETRIEBE UND BREMSE ANTRIEB .....	-	-	004Y	004Y	004Y	004Y
 MOTORE / ENGINE / MOTEUR / MOTOR 12,5 - 13 HP B&S ..... 16 - 18 HP B&S ..... 15,5 HP B&S ..... 20 HP B&S ..... 13 HP TECUMSEH ..... 15 HP TECUMSEH .....	005 005a 005b - 005d 005e	005 005a 005b - - -	005 005a 005b - 005d 005e	005 005a 005b - - -	- - - - - -	- 005a - 005c - -
 TRASMISSIONE TRANSMISSION TRANSMISSION GETRIEBE .....	006M	006M	006Y	006Y	006Y	006Y
 SOLLEVAMENTO PIATTO DI TAGLIO CUTTING PLATE LIFTING SOULEVEMENT PLATEAU DE COUPE SCHNEIDWERKZEUG AUFHEBESATZ .....	007	007	007	007	007	007
 PIATTO DI TAGLIO (1) CUTTING PLATE (1) PLATEAU DE COUPE (1) SCHNEIDWERKZEUG (1) .....	008	008	008	008	008	008

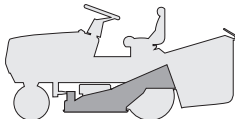
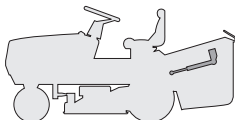
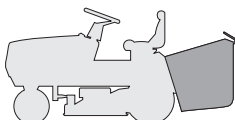
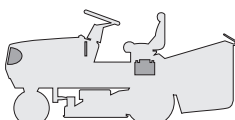
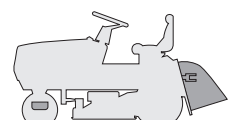
GRUPPO / UNIT / GROUPE / GRUPPE	TC102	TCP102	TC102 hydro	TCP102 hydro	TC122 hydro	TCP122 hydro
 PIATTO DI TAGLIO (2) CUTTING PLATE (2) PLATEAU DE COUPE (2) SCHNEIDWERKZEUG (2) .....	009	009	009	009	009	009
 SOLLEVAMENTO SACCO E MICRO SACCO PIENO LIFTING DEVICE AND FULL GRASSCATCHER MICRO SOULEVEMENT BAC ET MICRO BAC PLEIN AUSHEBENVORR. UND VOLLKORBEIN RICHTUNG .....	010	010	010	010	010	010
 SACCO GRASSCATCHER BAC AUFFANGSACK .....	011	011	011	011	011	011
 PARTI ELETTRICHE ELECTRICAL PARTS PARTIES ELECTRIQUES ELETRISCHETEILE .....	012M	012M	012Y	012Y	012Y	012Y
 ACCESSORI A RICHIESTA OPTIONALS ON REQUEST ACCESSOIRES SUR DEMANDE ZUBEHOERE NACH ANFRAGE .....	013	013	013	013	013	013
SCHEMA ELETTRICO WIRE DIAGRAM SCHEMA ELECTRIQUE ELEKTRISCHES SCHEMA 12,5 - 13 HP B&S - 13 - 15 HP TECUMSEH .....	014M	014M	014Y	014Y	014Y	-
15,5 HP B&S .....	014Ma	014Ma	014Ya	014Ya	-	-
16 - 18 - 20 HP B&S .....	014Mb	014Mb	014Yb	014Yb	-	014Yb

www.emc-motoculture.com

<b>TC102</b>	<b>TC102 hy.</b>	<b>TC122 hy.</b>
<b>TCP102</b>	<b>TCP102 hy.</b>	<b>TCP122 hy.</b>

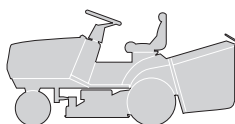

**ELENCO NUMERICO**  
**NUMERICAL LIST**  
**LISTE NUMERIQUE**  
**NUMERISCHE AUFSTELLUNG**

1999
<b>000.0</b>
5 / 8

CODE	TABLE	N.	Q.TY	CODE	TABLE	N.	Q.TY	CODE	TABLE	N.	Q.TY
12000955/0	007	34	4	12293201/0	001	27	1	12540260/0	012M	33	1
12001000/0	003	32	1	12293201/0	001	8	2	12540260/0	012Y	33	1
12001000/0	003	43	2	12293201/0	002	44	2	12540280/0	006M	25	1
12001000/0	004M	40	2	12293201/0	002	51	2	12543000/0	006M	3	1
12001000/0	004Y	32	1	12293201/0	004Y	17	1	12543000/0	006Y	3	1
12001000/0	004Y	74	2	12293201/0	005	14	3	12581100/0	006Y	19	2
12001010/0	006M	58	2	12293201/0	005a	17	3	12581200/0	002	23	2
12001010/0	006Y	58	2	12293201/0	005c	12	3	12582100/0	005a	12	5
12138810/0	006M	23	1	12293201/0	006M	51	4	12582100/0	005c	9	3
12139100/0	009	24	2	12293201/0	006Y	51	4	12582100/0	011	15	6
12139480/0	008	52	3	12293201/0	007	13	2	12583500/0	002	59	4
12141418/0	004M	47	1	12293201/0	008	33	4	12583500/0	002	63	2
12150000/0	013	5	1	12293201/0	010	4	4	12583500/0	004M	45	1
12154330/0	002	24	2	12295200/0	001	15	2	12583500/0	004Y	57	1
12154330/0	002	49	3	12295200/0	003	15	2	12583500/0	005a	20	2
12154330/0	008	70	2	12295200/0	003	18	2	12583500/0	005a	25	2
12154510/0	004M	10	2	12295200/0	003	19	2	12583500/0	005a	7	4
12154510/0	004M	36	1	12295200/0	003	27	2	12583500/0	005b	15	2
12154510/0	004M	51	1	12295200/0	003	28	2	12583500/0	005b	20	2
12154510/0	008	6	1	12295200/0	007	36	4	12583500/0	005b	5	2
12154510/0	010	29	1	12295800/0	003	35	1	12583500/0	005c	18	2
12155000/0	003	31	1	12360352/0	012M	31	2	12583500/0	005c	23	2
12155000/0	004M	13	1	12360352/0	012Y	31	2	12583500/0	005c	7	4
12155000/0	004M	15	1	12360354/1	006M	47	4	12583500/0	005d	15	2
12155000/0	004M	7	1	12360354/1	006Y	47	4	12583500/0	005d	20	2
12155000/0	004Y	39	1	12361010/0	006M	24	1	12583500/0	005d	5	2
12155000/0	004Y	43	2	12379511/0	001	33	1	12583500/0	005e	14	2
12155000/0	004Y	49	1	12379511/0	003	22	2	12583500/0	005e	19	2
12155000/0	004Y	53	1	12400030/0	010	54	1	12583500/0	005e	5	2
12155000/0	004Y	55	1	12436030/0	003	8	1	12583500/0	006M	28	4
12155000/0	006M	11	1	12436030/0	009	8	4	12583500/0	008	42	2
12155000/0	006M	14	1	12436050/0	009	4	2	12583500/0	008	55	1
12155000/0	006M	21	2	12500030/0	009	33	2	12583500/0	008	65	1
12155000/0	006M	42	2	12521300/0	006Y	18	2	12583500/0	008	78	1
12155000/0	006M	44	1	12521310/0	002	22	2	12583500/0	012Y	30	2
12155000/0	006Y	12	1	12521330/0	004M	16	2	12583501/0	004Y	9	1
12155000/0	006Y	42	2	12521330/0	004M	35	1	12585100/0	001	16	2
12155000/0	006Y	44	1	12521330/0	004M	50	2	12585100/0	003	46	2
12155000/0	006Y	9	1	12521330/0	010	28	1	12585100/0	003	47	2
12155000/0	007	22	2	12521331/0	011	16	6	12587900/0	003	37	1
12155000/0	007	32	2	12521350/0	002	62	2	12604897/0	002	56	2
12155000/0	008	48	4	12521350/0	004Y	38	2	12604898/0	010	32	1
12155000/0	008	75	1	12521350/0	004Y	42	2	12604899/0	007	9	1
12155000/0	009	22	6	12521350/0	004Y	51	2	12608900/0	004Y	46	2
12155000/0	010	10	2	12521350/0	007	21	2	12609200/0	008	38	2
12155000/0	010	39	2	12521350/0	007	31	4	12609255/0	007	25	2
12155000/0	013	24	3	12521350/0	008	20	1	12609260/0	004Y	7	1
12155010/0	006Y	16	2	12521350/0	008	41	2	12609260/0	007	18	1
12155010/0	008	9	1	12521350/0	008	47	5	12609260/0	009	19	2
12156602/0	007	37	4	12521350/0	009	21	6	12610800/0	008	37	2
12156602/0	009	11	4	12521350/0	010	38	2	12620206/0	007	10	1
12193200/0	004Y	56	2	12521350/0	010	9	2	12620299/0	003	2	1
12290791/0	006Y	20	2	12521370/0	003	7	1	12622650/0	003	5	1
12290800/0	002	20	1	12521390/0	003	36	2	12651010/0	006Y	17	2
12292100/0	008	19	2	12521410/0	007	17	1	12674550/0	008	5	1
12292100/0	011	14	4	12523020/0	002	14	2	12674701/0	011	13	2
12292102/0	002	7	2	12523060/0	004M	6	2	12689500/0	004M	49	1
12292102/0	008	58	3	12523060/0	006M	13	1	12689515/0	004M	34	1
12292102/0	010	24	2	12523060/0	006Y	11	1	12689515/0	005a	10	1
12293200/0	004M	44	1	12523060/0	008	21	1	12691100/0	001	26	1
12293200/0	004M	46	1	12523060/0	008	74	1	12691100/0	005	13	4
12293200/0	004Y	12	2	12523070/0	002	64	2	12691100/0	005a	16	4
12293200/0	004Y	58	1	12523070/0	006M	34	1	12691100/0	005b	7	4
12293200/0	005	14	1	12523070/0	006Y	34	1	12691100/0	005c	10	4
12293200/0	005a	17	1	12523070/0	008	77	1	12691100/0	005d	7	4
12293200/0	005b	9	1	12523080/0	009	28	2	12691200/0	008	46	3
12293200/0	005c	12	1	12523090/0	003	12	1	12691700/0	003	30	1
12293200/0	005d	9	1	12524010/0	006M	43	1	12691700/0	007	30	2
12293200/0	006M	17	2	12524010/0	006Y	43	1	12691700/0	008	45	1
12293200/0	006M	20	2	12540260/0	005	15	2	12692080/0	006M	8	1
12293200/0	006M	37	1	12540260/0	005	8	1	12692420/0	003	11	1
12293200/0	006Y	37	1	12540260/0	005a	26	2	12694100/0	003	34	1
12293200/0	008	50	1	12540260/0	005b	8	4	12726388/0	002	19	1
12293201/0	001	14	5	12540260/0	005c	11	2	12727810/0	002	28	3
12293201/0	001	20	4	12540260/0	005d	8	4	12728099/0	001	25	2



CODE	TABLE	N.	Q.TY	CODE	TABLE	N.	Q.TY	CODE	TABLE	N.	Q.TY
12728440/0	001	22	1	12793102/0	008	40	2	18737849/0	005d	11	1
12728440/0	001	29	1	12793102/0	008	53	1	18737849/0	005e	10	1
12728440/0	002	6	2	12793102/0	008	63	1	18737950/0	013	-	1
12728440/0	002	9	4	12793102/0	008	76	1	18738202/0	005a	4	1
12728440/0	010	55	2	12793102/0	009	2	2	18738203/0	005a	5	1
12729601/0	011	12	8	12793301/0	006M	52	2	18738206/0	005b	4	1
12731601/0	004M	4	4	12793301/0	006Y	15	2	18738211/0	005d	4	1
12731601/0	004Y	36	6	12793301/0	006Y	52	2	18738212/0	005e	4	1
12734995/0	001	31	4	12793500/0	002	42	1	18738214/0	005c	4	1
12734995/0	005e	24	1	12793900/0	008	49	1	18738215/0	005c	5	1
12735104/0	005	9	1	12815200/0	008	57	3	19035000/0	009	32	2
12735105/0	012M	18	3	12818700/0	009	20	6	19216032/0	009	17	4
12735105/0	012Y	18	3	12818900/0	008	73	1	19216033/1	008	36	2
12735106/0	005	5	4	12882020/0	006M	41	2	19410603/1	012M	14	4
12735106/0	005a	28	4	12882020/0	006Y	41	2	19410603/1	012Y	14	4
12735106/0	005b	22	4	15189001/0	006M	29	1	19410604/0	012M	21	1
12735106/0	005c	25	4	15189001/0	006Y	29	1	19410605/1	012M	22	1
12735106/0	005d	22	4	16694600/1	006M	46	1	19410605/1	012Y	22	1
12735106/0	005d	25	2	16694600/1	006Y	46	1	19410609/0	012Y	21	1
12735106/0	005e	21	4	18120002/1	012M	1	1	22034523/0	007	15	3
12735107/0	005a	22	4	18120002/1	012Y	1	1	22051337/0	008	18	1
12735107/0	005b	17	4	18159002/0	006M	26	1	22110230/0	003	48	2
12735107/0	005c	20	4	18210016/0	012M	13	1	22110230/0	006M	61	2
12735107/0	005d	17	4	18210016/0	012Y	13	1	22110230/0	006Y	61	2
12735107/0	005e	16	4	18210200/0	010	7	2	22160400/0	009	27	2
12735108/0	005e	8	1	18210201/0	004Y	14	1	22207319/0	006M	49	6
12735109/0	005e	7	3	18230000/0	012M	38	1	22207319/0	006Y	49	6
12735110/0	002	4	6	18230000/0	012Y	38	1	22524970/1	002	50	2
12735110/0	008	60	6	18310005/0	005a	27	1	22672150/0	003	13	2
12735110/0	012M	8	2	18310005/0	005b	21	1	22672151/0	008	8	1
12735110/0	012Y	8	2	18310005/0	005c	24	1	22672152/0	006M	35	2
12735402/0	001	10	4	18310005/0	005d	21	1	22672152/0	006Y	35	2
12735402/0	008	92	4	18310005/0	005e	20	1	22672153/0	004Y	6	1
12735510/0	005	7	1	18375051/1	005	3	3	22746600/0	003	17	2
12735530/0	005b	6	2	18375051/1	005a	3	1	22746600/0	003	26	2
12735530/0	005c	6	4	18375051/1	005b	3	1	22746601/0	004M	43	1
12735530/0	005d	6	2	18375051/1	005c	3	1	22746601/0	006M	19	2
12735530/0	005e	6	2	18375051/1	005d	3	1	22746602/0	004Y	15	1
12735530/0	006M	27	4	18375051/1	005e	3	1	22943005/0	006M	16	1
12735595/0	006Y	22	4	18375053/0	005	16	1	24487998/0	013	7	2
12735694/0	009	29	1	18375053/0	005a	29	1	24487999/0	013	46	2
12735695/1	009	30	1	18375053/0	005b	23	1	25020800/1	009	13	1
12737310/0	006M	2	1	18375053/0	005c	26	1	25020801/2	009	15	1
12737310/0	006Y	2	1	18375053/0	005d	23	1	25032001/1	011	4	1
12760512/0	013	23	3	18375053/0	005e	22	1	25032002/1	011	5	1
12769100/0	013	4	2	18390000/0	010	6	2	25033001/0	007	33	2
12771400/0	008	69	2	18395001/0	004Y	13	1	25033002/0	007	6	1
12788512/0	002	21	2	18400861/0	012M	11	1	25033003/1	003	16	1
12788910/0	002	13	2	18400861/0	012Y	11	1	25033004/0	004M	42	1
12789000/0	002	48	3	18400900/0	006Y	21	1	25033005/0	004M	5	1
12790780/0	002	5	2	18401001/0	005	12	1	25033007/0	004M	9	1
12791200/0	010	23	4	18401001/0	005a	15	1	25033015/0	010	33	1
12791200/0	010	27	1	18401001/0	005b	12	1	25033016/0	004Y	50	1
12791213/0	005a	11	1	18401001/0	005c	15	1	25033017/1	004Y	37	1
12791213/0	008	7	1	18401001/0	005d	12	1	25033018/0	010	33	1
12791400/0	005a	9	3	18401001/0	005e	11	1	25033060/0	009	31	2
12791400/0	005c	8	3	18450060/0	012M	6	1	25034002/0	004Y	4	2
12792099/0	011	11	4	18450060/0	012Y	6	1	25034002/1	003	21	4
12792610/0	005a	24	2	18450065/1	012M	10	1	25038000/0	008	44	4
12792610/0	005c	22	2	18450065/1	012Y	10	1	25038002/0	006M	10	2
12792611/0	002	43	1	18459100/0	012M	4	2	25038002/0	006Y	7	1
12792611/0	005b	19	2	18459100/0	012Y	4	2	25038002/0	009	3	4
12792611/0	005d	19	2	18564600/0	010	5	2	25040601/0	004M	41	2
12792611/0	005e	18	2	18564861/0	012M	35	1	25040601/0	004Y	72	2
12792611/0	007	12	2	18564861/0	012Y	35	1	25040602/0	004M	38	2
12792611/0	008	32	4	18564862/0	012M	2	1	25040605/0	007	28	4
12792611/0	010	3	4	18564862/0	012Y	2	1	25040607/0	006M	31	1
12792612/0	004Y	8	1	18565351/0	012M	12	1	25040607/0	006Y	31	1
12793101/0	002	58	4	18565351/0	012Y	12	1	25040608/0	006M	39	2
12793101/0	005a	6	4	18716131/1	005a	21	1	25040608/0	006Y	39	2
12793101/0	010	8	2	18716131/1	005c	19	1	25040614/0	004Y	45	2
12793102/0	001	18	1	18716132/0	005b	16	1	25060100/1	008	59	1
12793102/0	001	18	2	18716132/0	005d	16	1	25060101/0	008	59	1
12793102/0	001	19	2	18716132/0	005e	15	1	25065001/0	012M	28	1
12793102/0	005a	19	2	18736110/0	012M	7	1	25065001/0	012Y	28	1
12793102/0	005b	14	1	18736110/0	012Y	7	1	25065002/0	012M	29	1
12793102/0	005c	17	2	18737849/0	005	11	1	25065002/0	012Y	29	1
12793102/0	005d	14	2	18737849/0	005a	14	1	25065003/0	012M	26	1
12793102/0	005e	13	2	18737849/0	005b	11	1	25065003/0	012Y	26	1
12793102/0	006Y	8	1	18737849/0	005c	14	1	25065004/0	012M	27	1



CODE	TABLE	N.	Q.TY	CODE	TABLE	N.	Q.TY	CODE	TABLE	N.	Q.TY
25065004/0	012Y	27	1	25430200/0	012Y	3	2	25598050/0	005e	9	1
25065005/0	012M	32	1	25430202/0	002	55	1	25600000/0	008	91	1
25065009/0	012M	39	1	25430203/0	002	46	1	25600007/0	012M	16	1
25065009/0	012Y	39	1	25430205/0	002	60	2	25600007/0	012Y	16	1
25065010/1	012M	40	1	25430206/1	008	4	1	25600008/0	008	91	1
25065010/1	012Y	40	1	25430207/0	006M	32	1	25600009/0	012M	16	1
25065011/0	012M	34	1	25430207/0	006Y	32	1	25600009/0	012Y	16	1
25065011/0	012M	34	1	25430208/0	007	8	1	25600010/0	002	26	1
25065011/0	012Y	34	1	25430209/0	003	45	8	25600031/0	005d	24	1
25065011/0	012Y	34	1	25430209/0	006M	60	8	25600038/0	005e	23	1
25065015/0	012Y	32	1	25430209/0	006Y	60	8	25600039/0	010	52	1
25065023/0	012M	42	1	25430210/0	004Y	59	1	25600040/0	010	51	1
25065023/0	012Y	43	1	25430210/0	008	79	1	25601549/0	008	62	1
25076802/0	001	5	1	25430212/1	004M	11	1	25601550/0	008	62	1
25076808/0	001	5	1	25430213/0	004M	14	1	25601552/2	006M	1	1
25090000/0	002	16	1	25430213/0	010	35	1	25601554/0	006M	12	1
25090001/0	002	16	1	25430215/0	002	25	2	25601554/0	006Y	10	1
25110157/1	001	9	1	25430216/0	013	3	1	25601555/0	008	71	1
25110159/0	001	9	1	25430217/0	001	24	2	25601557/0	007	20	2
25110161/0	001	9	1	25430218/0	001	23	2	25601559/1	008	35	2
25110163/0	001	9	1	25430219/0	006M	15	1	25601560/0	008	51	2
25110170/0	001	9	1	25430219/0	006Y	13	1	25601561/0	008	35	2
25110171/0	001	9	1	25430220/0	008	79	1	25601562/0	008	51	2
25110172/0	001	9	1	25430220/0	010	25	1	25601565/1	006Y	1	1
25110173/0	001	9	1	25430223/0	002	66	1	25605000/1	007	3	1
25110260/1	001	11	1	25430224/0	002	47	1	25650021/0	001	17	2
25110261/1	001	12	1	25430225/0	004M	33	1	25650037/0	008	39	1
25110265/0	004Y	2	1	25430228/0	001	28	1	25670002/0	003	14	1
25110266/0	004Y	3	1	25430231/0	004Y	52	1	25670005/1	003	42	2
25110267/0	004Y	33	1	25463200/0	009	28	2	25670005/1	006M	57	2
25110268/0	001	12	1	25470901/0	007	4	1	25670005/1	006Y	57	2
25110269/0	004M	2	1	25510000/0	002	54	1	25670006/0	004M	39	2
25120149/0	002	8	1	25510006/0	009	7	4	25670006/0	004Y	73	2
25120150/0	002	8	1	25510011/0	007	5	1	25670007/0	008	54	1
25120153/0	002	8	1	25510015/1	001	7	2	25670007/0	008	64	1
25120155/0	002	8	1	25510016/0	002	61	2	25670008/0	007	35	2
25122000/0	002	65	2	25510017/0	004M	12	1	25670008/0	009	10	8
25122200/1	003	41	4	25510021/0	013	45	1	25670009/0	006M	40	2
25122201/0	006M	50	3	25510022/0	013	6	2	25670009/0	006Y	40	2
25122201/0	006Y	50	3	25510024/0	009	9	4	25670011/0	004Y	48	2
25140201/0	006M	45	1	25510038/0	010	37	2	25722406/0	012M	15	1
25140201/0	006Y	45	1	25510041/1	004Y	47	1	25722406/0	012Y	15	1
25160001/1	003	10	2	25510041/0	004Y	54	1	25722407/0	012M	15	1
25160002/0	008	66	1	25510099/4	013	22	1	25722407/0	012Y	15	1
25160003/0	008	43	4	25520002/0	003	3	1	25722450/0	002	57	1
25160004/0	007	16	1	25547005/0	010	1	1	25722451/1	002	57	1
25160005/0	003	33	1	25547007/0	010	2	1	25730000/0	001	6	1
25160006/0	006M	36	1	25547012/0	004M	3	1	25730001/0	001	6	1
25160006/0	006Y	36	1	25547014/0	001	3	1	25730002/0	001	6	1
25160007/0	008	72	1	25547014/0	011	10	1	25730003/0	001	6	1
25160008/0	006M	9	1	25547015/0	001	3	1	25735110/2	002	11	1
25160010/0	006M	48	2	25547015/0	011	10	1	25735111/2	002	11	1
25160010/0	006Y	48	2	25547016/1	001	3	1	25735501/0	007	11	1
25160501/0	009	18	2	25547016/1	011	10	1	25774211/1	008	3	1
25207000/1	008	68	1	25547024/0	001	3	1	25774213/0	013	43	1
25207200/0	009	16	2	25547024/0	011	10	1	25774220/0	010	22	2
25260000/0	002	10	2	25547025/0	001	3	1	25774235/0	002	27	1
25290000/0	002	15	1	25547025/0	011	10	1	25785010/0	012M	41	1
25318109/0	002	53	1	25547026/0	001	3	1	25785010/0	012Y	41	1
25318112/0	010	53	1	25547026/0	011	10	1	25785055/0	010	26	1
25318115/0	008	67	1	25547027/0	001	3	1	25785095/0	005a	8	1
25318117/0	004M	48	1	25547027/0	011	10	1	25795000/0	002	12	1
25318119/0	008	67	1	25547028/0	001	3	1	25840001/0	003	25	1
25318120/0	008	1	1	25547028/0	011	10	1	25840004/0	004Y	41	1
25318122/0	006M	30	2	25547039/0	004Y	34	1	25869006/0	005	17	1
25318122/0	006Y	30	2	25547041/0	004Y	35	1	25869016/0	005	2	1
25394500/1	004M	8	1	25570000/0	003	4	1	25869016/0	005b	2	1
25394500/1	004Y	40	1	25570001/0	006M	38	2	25869016/0	005c	2	1
25394500/1	010	34	1	25570001/0	006Y	38	2	25869017/0	005a	2	1
25394501/0	002	18	1	25590000/0	003	40	2	25869027/0	005d	2	1
25394503/1	008	10	1	25590001/0	006M	56	2	25869027/0	005e	2	1
25394504/0	007	7	1	25590001/0	006Y	56	2	25943002/0	006M	33	1
25410858/0	001	4	1	25597121/0	001	32	2	25943002/0	006Y	33	1
25410860/0	001	4	1	25598002/0	004Y	11	1	25950000/0	006M	62	2
25410861/0	001	4	1	25598002/0	006M	18	1	25950000/0	006Y	62	2
25420000/1	012M	19	1	25598050/0	005	10	1	25950002/0	003	49	2
25420000/1	012Y	19	1	25598050/0	005a	13	1	25961200/0	003	1	1
25420001/1	012M	19	1	25598050/0	005b	10	1	29394505/1	004M	31	1
25420001/1	012Y	19	1	25598050/0	005c	13	1	33320505/0	012M	36	1
25430200/0	012M	3	2	25598050/0	005d	10	1	33320505/0	012Y	36	1





TC102 TC102 hy. TC122 hy.

TCP102 TCP102 hy. TCP122 hy.

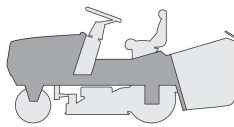

CARROZZERIA E CHASSIS  
BODY AND CHASSIS  
CARROSSERIE ET CHASSIS  
KARROSSERIE UND GEHÄUSE

1999

001.0

1 / 2

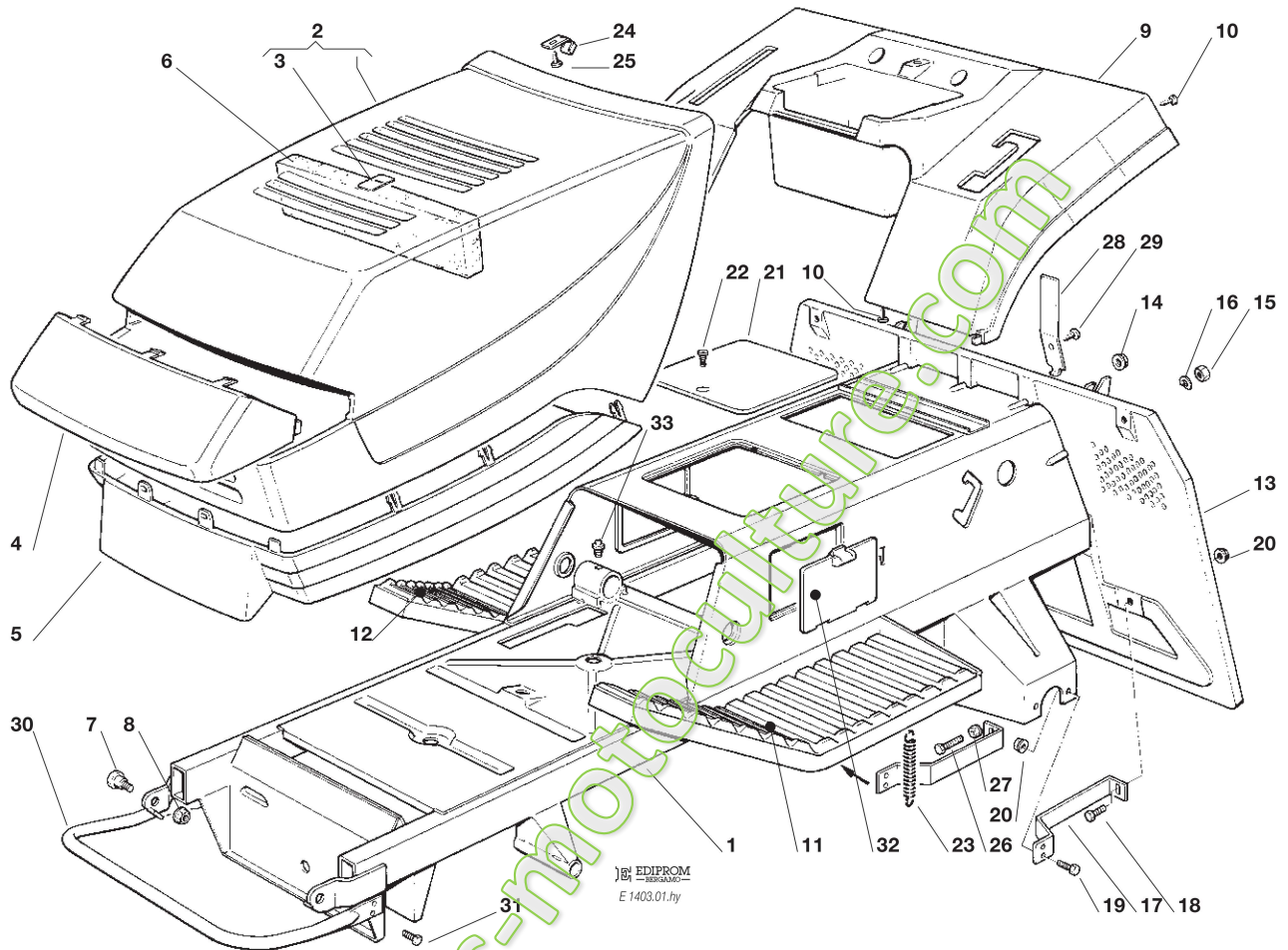

N.	CODE	Q.TY	DESCRIZIONE	DESCRIPTION	DESCRIPTION	BESCHREIBUNG
1	82800004/7	1	TELAIO	CHASSIS	CHASSIS	RAHMENSATZ
	82800023/0	1	TELAIO ( <i>hydro</i> )	CHASSIS ( <i>hydro</i> )	CHASSIS ( <i>hydro</i> )	RAHMENSATZ ( <i>hydro</i> )
2	☛	1	COFANO SUPER. (TC)	UPPER ENGINE HOOD (TC)	CAPOT SUPERIEURE (TC)	OBERHAUBESATZ (TC)
	82076801/1		ROSSO	RED	ROUGE	ROT
	82076804/0		VERDE	GREEN	VERT	GRÜN
	82076805/0		GIALLO	YELLOW	JAUNE	GELB
	82076807/0		BLU	BLUE	BLEU	BLAU
☛		1	COFANO SUPER. (TCP)	UPPER ENGINE HOOD (TCP)	CAPOT SUPERIEURE (TCP)	OBERHAUBESATZ (TCP)
	82076840/0		ROSSO	RED	ROUGE	ROT
	82076842/0		VERDE	GREEN	VERT	GRÜN
	82076844/0		GIALLO	YELLOW	JAUNE	GELB
	82076846/0		BLU	BLUE	BLEU	BLAU
3	☛	1	PIASTRINA (TC)	PLATE (TC)	PLAQUE (TC)	PLATTE (TC)
	25547016/1		ROSSA	RED	ROUGE	ROT
	25547015/0		VERDE	GREEN	VERT	GRÜN
	25547014/0		GIALLA	YELLOW	JAUNE	GELB
	25547024/0		BLU	BLUE	BLEU	BLAU
☛		1	PIASTRINA (TCP)	PLATE (TCP)	PLAQUE (TCP)	PLATTE (TCP)
	25547025/0		ROSSA	RED	ROUGE	ROT
	25547026/0		VERDE	GREEN	VERT	GRÜN
	25547027/0		GIALLA	YELLOW	JAUNE	GELB
	25547028/0		BLU	BLUE	BLEU	BLAU
4	25410858/0	1	MASCHERINA (TC)	GRILL (TC)	PANNEAU (TC)	SCHUTZ (TC)
	25410860/0	1	MASCHERINA DX (TCP)	RIGHT GRILL (TCP)	PANNEAU DROITE (TCP)	RECHTE SCHUTZ (TCP)
	25410861/0	1	MASCHERINA SX (TCP)	LEFT GRILL (TCP)	PANNEAU GAUCHE (TCP)	LINKE SCHUTZ (TCP)
5	25076802/0	1	COFANO INFERIORE (TC)	LOWER ENGINE HOOD (TC)	CAPOT INFERIEURE (TC)	UNTERHAUBESATZ (TC)
	25076808/0	1	COFANO INFERIORE (TCP)	LOWER ENGINE HOOD (TCP)	CAPOT INFERIEURE (TCP)	1 UNTERHAUBESATZ (TCP)
6	☛	1	SEPARATORE ASPIRAZ.	INTAKE SEPARATOR	SEPARATEUR ASPIRATIONS	AUGENABSCHIEDER
	25730000/0		TC - 13 HP TECUMSEH	TC - 13 HP TECUMSEH	TC - 13 HP TECUMSEH	TC - 13 HP TECUMSEH
			15,5 - 16 HP B&S	15,5 - 16 HP B&S	15,5 - 16 HP B&S	15,5 - 16 HP B&S
	25730001/0		15 HP TECUMSEH	15 HP TECUMSEH	15 HP TECUMSEH	15 HP TECUMSEH



N.	CODE	Q.TY	DESCRIZIONE	DESCRIPTION	DESCRIPTION	BESCHREIBUNG
	25730002/0		<b>TCP - 12,5-13-18 HP B&amp;S</b>	<b>TCP - 12,5-13-18 HP B&amp;S</b>	<b>TCP - 12,5-13-18 HP B&amp;S</b>	<b>TCP - 12,5-13-18 HP B&amp;S</b>
	25730003/0		20 HP B&S	20 HP B&S	20 HP B&S	20 HP B&S
7	25510015/1	2	PERNO	PIN	PIVOT	BOLZEN
8	12293201/0	2	DADO	NUT	ECROU	MUTTER
9	☛	1	COPERTURA RUOTE <b>(TC)</b>	WHEELS COVER <b>(TC)</b>	COUVRE-ROUES <b>(TC)</b>	RADENKAPPE <b>(TC)</b>
	25110157/1		ROSSA	RED	ROUGE	ROT
	25110159/0		VERDE	GREEN	VERT	GRÜN
	25110161/0		GIALLO	YELLOW	JAUNE	GELB
	25110163/0		BLU	BLUE	BLEU	BLAU
☛	1	COPERTURA RUOTE <b>(TCP)</b>	WHEELS COVER <b>(TCP)</b>	COUVRE-ROUES <b>(TCP)</b>	FADENKAPPE <b>(TCP)</b>	
	25110170/0		ROSSA	RED	ROUGE	ROT
	25110171/0		VERDE	GREEN	VERT	GRÜN
	25110172/0		GIALLO	YELLOW	JAUNE	GELB
	25110173/0		BLU	BLUE	BLEU	BLAU
10	12735402/0	4	VITE	SCREW	VIS	SCHRAUBE
11	25110260/1	1	COPRIPEDANA SX	LEFT FOOTBOARD COVER GAUCHE	COUVRE MARCHEPIED	LINKE FUSSBRETTDECKEL
12	25110261/1	1	COPRIPEDANA DX	RIGHT FOOTBOARD COVER DROITE	COUVRE MARCHEPIED	RECHTE FUSSBRETTDECKEL
	25110268/0	1	COPRIPEDANA DX <b>(hydro)</b>	RIGHT FOOTBOARD COVER <b>(hydro)</b>	COUVRE MARCHEPIED DROITE <b>(hydro)</b>	RECHTE FUSSBRETTDECKEL <b>(hydro)</b>
13	82547001/3	1	PIASTRA POST.	REAR PLATE	PLAQUE POSTERIEURE	HINTERPLATTE
14	12293201/0	5	DADO	NUT	ECROU	MUTTER
15	12295200/0	2	DADO	NUT	ECROU	MUTTER
16	12585100/0	2	GROWER	GROWER	GROWER	GROWER
17	25650021/0	2	RINFORZO PIASTRA POST.	REAR PLATE STIFFENING POST.	REINFORCEMENT PLAQUE ERKUNIG	HINTERPLATTEVERSTA-
18	12793102/0	2	VITE <b>(TC)</b>	SCREW <b>(TC)</b>	VIS <b>(TC)</b>	SCHRAUBE <b>(TC)</b>
18	12793102/0	1	VITE <b>(TCP)</b>	SCREW <b>(TCP)</b>	VIS <b>(TCP)</b>	SCHRAUBE <b>(TCP)</b>
19	12793102/0	2	VITE	SCREW	VIS	SCHRAUBE
20	12293201/0	4	DADO	NUT	ECROU	MUTTER
21	82597120/0	1	PORTINA	HANDHOLE	GRILLE	GITTER
22	12728440/0	1	VITE	SCREW	VIS	MUTTER
23	25430218/0	2	MOLLA	SPRING	RESSORT	FEDER
24	25430217/0	2	MOLLA AGGANCI <b>(TCP)</b>	COUPLING SPRING <b>(TCP)</b>	RESSORT ACCROCHA <b>(TCP)</b>	GEKUPPLUNGSFEDER <b>(TCP)</b>
25	12728099/0	2	VITE <b>(TCP)</b>	SCREW <b>(TCP)</b>	VIS <b>(TCP)</b>	SCHRAUBE <b>(TCP)</b>
26	12691100/0	1	VITE <b>(TCP)</b>	SCREW <b>(TCP)</b>	VIS <b>(TCP)</b>	SCHRAUBE <b>(TCP)</b>
27	12293201/0	1	DADO <b>(TCP)</b>	NUT <b>(TCP)</b>	ECROU <b>(TCP)</b>	MUTTER <b>(TCP)</b>
28	25430228/0	1	MOLLA	SPRING	RESSORT	FEDER
29	12728440/0	1	VITE	SCREW	VIS	SCHRAUBE
30	82869006/0	1	PROTEZIONE SILENZIATORE	MUFFLER PROTECTION	PROTECTION SILENCIEUX	AUSPUFFSCHUTZ
31	12734995/0	4	VITE	SCREW	VIS	SCHRAUBE
32	25597121/0	2	PORTINA <b>(hydro)</b>	HANDHOLE <b>(hydro)</b>	GRILLE <b>(hydro)</b>	GITTER <b>(hydro)</b>
33	12379511/0	1	INGRASSATORE <b>(hydro)</b>	GREASE DISPENSER <b>(hydro)</b>	GRAISSEUR <b>(hydro)</b>	FETTBUCHSE <b>(hydro)</b>

www.eric-motocycle.com

TC102

TC102 hy.

TC122 hy.

TCP102

TCP102 hy.

TCP122 hy.

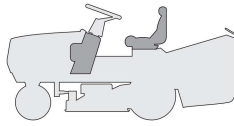

**CRUSCOTTO E SEDILE**  
**DASHBOARD AND SEAT**  
**TABLEAU COMMANDES ET SIEGE**  
**KONSOLE UND SITZ**

1999

002.0

1 / 2

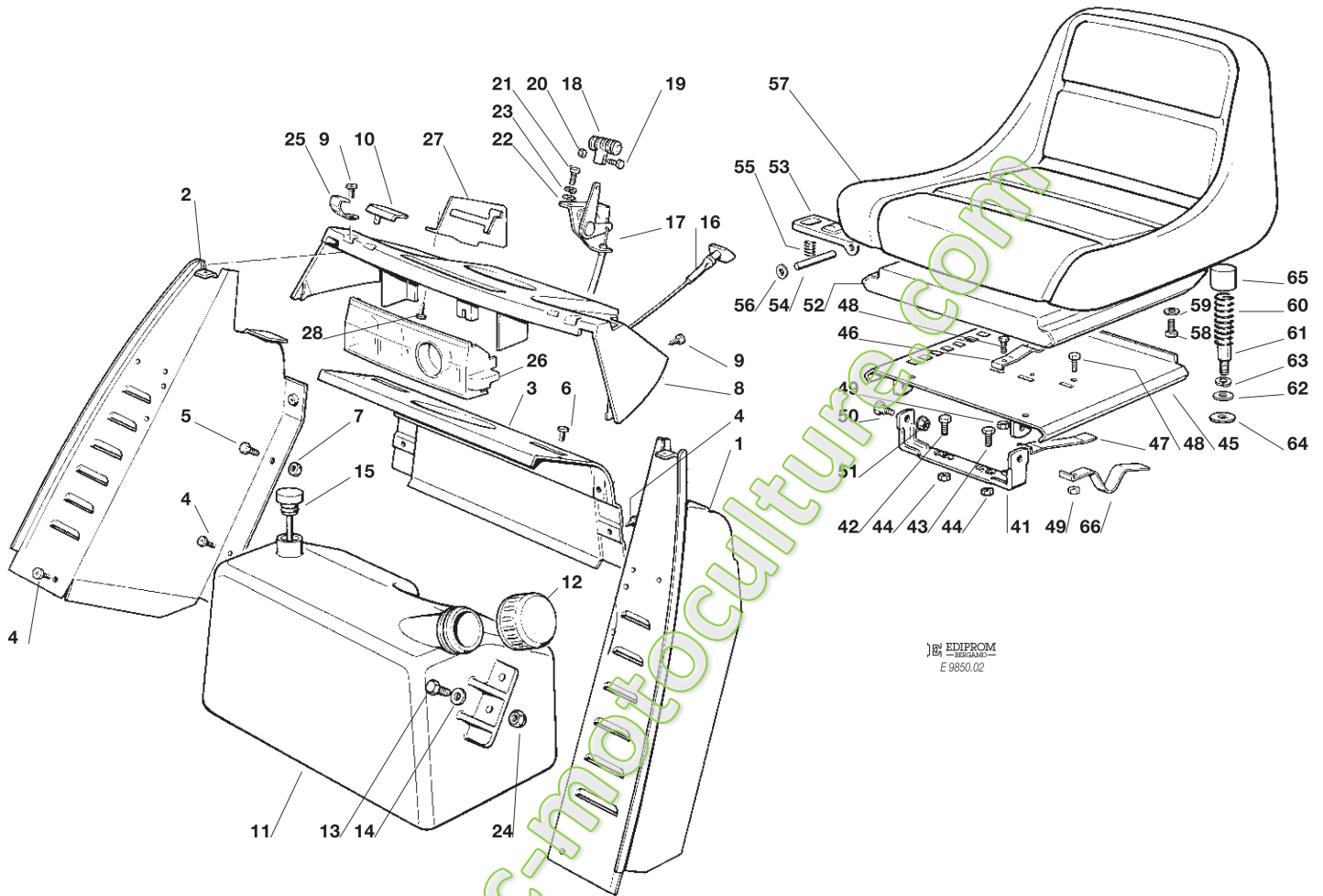

EDIPROM  
 E 9850.02

N.	CODE	Q.TY	DESCRIZIONE	DESCRIPTION	DESCRIPTION	BESCHREIBUNG
1	82785021/3	1	SUPP. CRUSCOTTO SX	LEFT DASHBOARD SUPP.	SUPPORT TABLEAU GAUCHE	LINKER KONSELEHALTER
2	82785022/2	1	SUPP. CRUSCOTTO DX	RIGHT DASHBOARD SUPP.	SUPPORT TABLEAU DROITE	RECHTER KONSELEHALTER
3	82785023/0	1	SUPP. CRUSCOTTO CENTR. SUPP.	CENTRAL DASHBOARD SUPP.	SUPPORT TABLEAU HALTER	ZENTRALER KONSELE HALTER
4	12735110/0	6	VITE	SCREW	VIS	SCHRAUBE
5	12790780/0	2	VITE	SCREW	VIS	SCHRAUBE
6	12728440/0	2	VITE	SCREW	VIS	SCHRAUBE
7	12292102/0	2	DADO	NUT	ECROU	MUTTER
8	25120149/0	1	CRUSCOTTO (TC)	DASHBOARD (TC)	TABEAU DE BORD (TC)	KONSOLE (TC)
	25120150/0	1	CRUSCOTTO (TCP)	DASHBOARD (TCP)	TABEAU DE BORD (TCP)	KONSOLE (TCP)
	25120155/0	1	CRUSCOTTO (TC hydro)	DASHBOARD (TC hydro)	TABEAU DE BORD (TC hy.)	KONSOLE (TC hydro)
	25120153/0	1	CRUSCOTTO (TCP hydro)	DASHBOARD (TCP hydro)	TABEAU DE BORD (TCP hy.)	KONSOLE (TCP hydro)
9	12728440/0	4	VITE	SCREW	VIS	SCHRAUBE
10	25260000/0	2	GOMMINO	GROMMET	PROTECTION	SCHUTZ
11	25735110/2	1	SERBATOIO	TANK	RESERVOIR	TANK
			(12,5 - 15,5 HP B&S	(12,5 - 15,5 HP B&S	(12,5 - 15,5 HP B&S	(12,5 - 15,5 HP B&S
			13 - 15 HP TECUMSEH)	13 - 15 HP TECUMSEH)	13 - 15 HP TECUMSEH)	13 - 15 HP TECUMSEH)
	25735111/2	1	SERBATOIO	TANK	RESERVOIR	TANK
			(16 - 18 - 20 HP B&S)	(16 - 18 - 20 HP B&S)	(16 - 18 - 20 HP B&S)	(16 - 18 - 20 HP B&S)
12	25795000/0	1	TAPPO	CAP	BOUCHON	TANKVERSCHLUSS
13	12788910/0	2	VITE	SCREW	VIS	SCHRAUBE
14	12523020/0	2	RONDELLA	WASHER	RONDELLE	SCHIBE
15	25290000/0	1	INDICATORE LIVELLO	FUEL LEVEL INDICATOR	INDICATEUR NIVEAU	KRAFTSTOFFMESSER
			(16 - 18 - 20 HP B&S)	(16 - 18 - 20 HP B&S)	(16 - 18 - 20 HP B&S)	(16 - 18 - 20 HP B&S)
16	25090000/0	1	COMANDO STARTER	STARTER DRIVE	COMMANDE STARTER	STARTER BETAETIGUNG
			(16 - 18 HP B&S)	(16 - 18 HP B&S)	(16 - 18 HP B&S)	(16 - 18 HP B&S)
16	25090001/0	1	COMANDO STARTER	STARTER DRIVE	COMMANDE STARTER	STARTER BETAETIGUNG
			(20 HP B&S)	(20 HP B&S)	(20 HP B&S)	(20 HP B&S)
17	82000200/1	1	ACCELERATORE	ACCELERATOR	ACCELERATEUR	GAS ZUG 1
			12,5 - 13 - 15,5 HP B&S	12,5 - 13 - 15,5 HP B&S	12,5 - 13 - 15,5 HP B&S	12,5 - 13 - 15,5 HP B&S
			13 - 15 HP TECUMSEH	13 - 15 HP TECUMSEH	13 - 15 HP TECUMSEH	13 - 15 HP TECUMSEH



N.	CODE	Q.TY	DESCRIZIONE	DESCRIPTION	DESCRIPTION	BESCHREIBUNG
	82000201/1	1	ACCELERATORE 16 - 18 - 20 HP B&S	ACCELERATOR 16 - 18 - 20 HP B&S	ACCELERATEUR 16 - 18 - 20 HP B&S	GAS ZUG 16 - 18 - 20 HP B&S
18	25394501/0	1	MANOPOLA	HANDLE	POIGNE	GRIFF
19	12726388/0	1	VITE	SCREW	VIS	SCHRAUBE
20	12290800/0	1	DADO	NUT	ECROU	MUTTER
21	12788512/0	2	VITE	SCREW	VIS	SCHRAUBE
22	12521310/0	2	RONDELLA	WASHER	RONDELLE	SCHEIBE
23	12581200/0	2	GROWER	GROWER	GROWER	GROWER
24	12154330/0	2	DADO	NUT	ECROU	MUTTER
25	25430215/0	2	MOLLA AGGANCIO (TC)	COUPLING SPRING (TC)	RESSORT ACCROCHAGE (TC)	KUPLUNGSFEDER (TC)
26	25600010/0	1	PROTEZIONE SCHEDA	CARD PROTECTION	PROTECTION DE CARTE	KARTESCHUTZ
27	25774235/0	1	STAFFA GUIDA	PLATE	ETRIER	BRIDE
28	12727810/0	3	VITE	SCREW	VIS	SCHRAUBE
41	82774207/0	1	STAFFA SUPP. SEDILE	SEAT CLAMP SUPPORT	ETRIER SUPPORT SIEGE	BRIDE F. SITZHALTER
42	12793500/0	1	VITE	SCREW	VIS	SCHRAUBE
43	12792611/0	1	VITE	SCREW	VIS	SCHRAUBE
44	12293201/0	2	DADO	NUT	ECROU	MUTTER
45	82785089/0	1	SUPP. SEDILE FISSO	FIXED SEAT SUPP.	SUPPORT SIEGE FIXE	FEST SITZHALTER
46	25430203/0	1	MOLLA ARRESTO	SPRING	RESSORT D'ARRET	RASTFEDER
47	25430224/0	1	MOLLA COMANDO	SPRING	RESSORT DE COMMANDE	FEDER
48	12789000/0	3	VITE	SCREW	VIS	SCHRAUBE
49	12154330/0	3	DADO	NUT	ECROU	MUTTER
50	22524970/1	2	PERNO	PIN	PIVOT	BOLZEN
51	12293201/0	2	DADO	NUT	ECROU	MUTTER
52	82785087/0	1	SUPPORTO SEDILE	SEAT SUPPORT	SUPPORT SIEGE	SITZHALTER
53	25318109/0	1	LEVA ARRESTO	STOP LEVER	LEVIER D'ARRET	ABSTELLHEBEL
54	25510000/0	1	PERNO	PIN	PIVOT	BOLZEN
55	25430202/0	1	MOLLA	SPRING	RESSORT	FEDER
56	12604897/0	2	RONDELLA	WASHER	RONDELLE	SCHEIBE
57	25722450/0	1	SEDILE (TC)	SEAT (TC)	SIEGE (TC)	SITZ (TC)
	25722451/1	1	SEDILE (TCP)	SEAT (TCP)	SIEGE (TCP)	SITZ (TCP)
58	12793101/0	4	VITE	SCREW	VIS	SCHRAUBE
59	12583500/0	4	GROWER	GROWER	GROWER	GROWER
60	25430205/0	2	MOLLA	SPRING	RESSORT	FEDER
61	25510016/0	2	PERNO	PIN	PIVOT	BOLZEN
62	12521350/0	2	RONDELLA	WASHER	RONDELLE	SCHEIBE
63	12583500/0	2	GROWER	GROWER	GROWER	GROWER
64	12523070/0	2	RONDELLA	WASHER	RONDELLE	SCHEIBE
65	25122000/0	2	CUFFIA PROTEZ.	HOOD	PROTECTEUR	SCHUTZKASTEN
66	25430223/0	1	MOLLA	SPRING	RESSORT	FEDER

www.emc-motocycle.com

TC102

TC102 hy.

TC122 hy.

TCP102

TCP102 hy.

TCP122 hy.

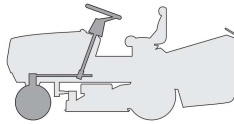

**STERZO**  
**STEERING**  
**BARRE DE DIRECTION**  
**LENKGETRIEBE**

1999

003.0

1 / 2

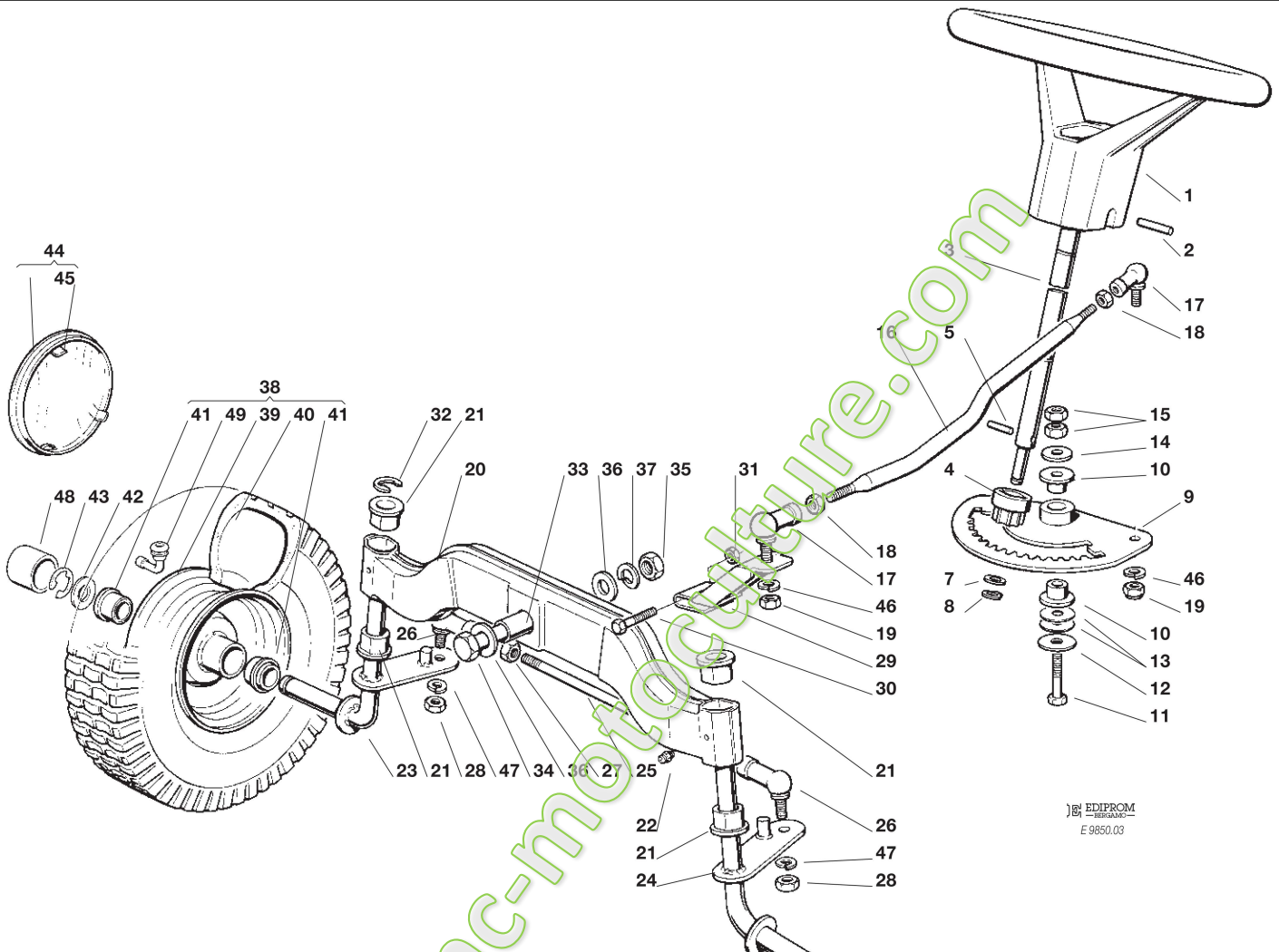

EDIPROM  
E 9850.03

N.	CODE	Q.TY	DESCRIZIONE	DESCRIPTION	DESCRIPTION	BESCHREIBUNG
1	25961200/0	1	VOLANTE	STEERING WHEEL	VOLANT	LENKRAD
2	12620299/0	1	SPINA	PIN	GOUPILLE	STIFT
3	25520002/0	1	PIANTONE	STEERING COLUMN	TUBE DE DIRECTION	LENKUNGSAEULE
4	25570000/0	1	PIGNONE	PINION	PIGNON	RITZEL
5	12622650/0	1	SPINA	PIN	GOUPILLE	STIFT
7	12521370/0	1	RONDELLA	WASHER	RONDELLE	SCHEIBE
8	12436030/0	1	PIASTRINA	PLATE	PLAQUETTE	PLATTECHEN
9	82735504/0	1	SETTORE STERZO	STEERING SHAFT	ARBRE DIRECTION	LENKUNGSWELLE
10	25160001/1	2	BRONZINA	BRASS	COUSSINET	BÜCHSE
11	12692420/0	1	VITE	SCREW	VIS	SCHRAUBE
12	12523090/0	1	RONDELLA	WASHER	RONDELLE	SCHEIBE
13	22672150/0	2	RONDELLA	WASHER	RONDELLE	SCHEIBE
14	25670002/0	1	RONDELLA	WASHER	RONDELLE	SCHEIBE
15	12295200/0	2	DADO	NUT	ECROU	MUTTER
16	25033003/1	1	ASTA COMANDO STERZO	STEERING ROD	LEVIER BARRE DE DIRECTION	LENKUNGSSTAB
17	22746600/0	2	SNODO M10	JOINT M10	JOINT M10	GELENK M10
18	12295200/0	2	DADO	NUT	ECROU	MUTTER
19	12295200/0	2	DADO	NUT	ECROU	MUTTER
20	82034001/1	1	BILANCIERE COMPLETO DI BRONZINA ED INGRASSATORE	EQUALIZER WITH BUSH AND LUBRICATOR	BALANCIER AVEC COUSSINET ET GRAISSEUR	KIPPHEBEL MIT BRONZE-LAGER UND FETTBÜCHSE
21	25034002/1	4	BRONZINA	BRASS	COUSSINET	BÜCHSE
22	12379511/0	2	INGRASSATORE	GREASE DISPENSER	GRAISSEUR	FETTBÜCHSE
23	82230349/0	1	FUSELLO DX	R. STUB AXLE	FUSEAU DROITE	RECHTER ACHSSCHENKEL
24	82230348/0	1	FUSELLO SX	L. STUB AXLE	FUSEAU GAUCHE	LINKER ACHSSCHENKEL
25	25840001/0	1	TIRANTE	TIE ROD	TIRANT	KUPPLUNG
26	22746600/0	2	SNODO M10	JOINT M10	JOINT M10	GELENK M10
27	12295200/0	2	DADO	NUT	ECROU	MUTTER
28	12295200/0	2	DADO	NUT	ECROU	MUTTER
29	82318101/0	1	ASS. LEVA COMANDO	LEVER ASS.Y	ENSEMBLE LEVIER	HEBEL



N.	CODE	Q.TY	DESCRIZIONE	DESCRIPTION	DESCRIPTION	BESCHREIBUNG
30	12691700/0	1	VITE	SCREW	VIS	SCHRAUBE
31	12155000/0	1	DADO	NUT	ECROU	MUTTER
32	12001000/0	1	ANELLO ELASTICO	SNAP RING	ANNEAU RESSORT	SPRENGRING
33	25160005/0	1	DISTANZIALE	SPACER	ENTRETOISE	ENTFERNUNGSSTUECK
34	12694100/0	1	VITE	SCREW	VIS	SCHRAUBE
35	12295800/0	1	DADO	NUT	ECROU	MUTTER
36	12521390/0	2	RONDELLA	WASHER	RONDELLE	SCHEIBE
37	12587900/0	1	GROWER	GROWER	GROWER	GROWER
38	82680002/1	2	RUOTA COMPLETA CON CUSCINETTI (TURF-SAVER)	WHEEL ASS.Y WITH BEARINGS (TURF-SAVER)	ENSEMBLE ROUE AVEC ROULEM. (TURF-SAVER)	VORDERRAD MIT KUGEL LAGER (TURF-SAVER)
39	82000590/0	2	CERCHIO RUOTA ANT.	FRONT RIMM	BANDAGE ROUE ANT.	VORDERRAD FELGER
40	25590000/0	2	PNEUMATICO (TURF-SAVER)	SHOE (TURF-SAVER)	PNEU (TURF-SAVER)	REIFEN (TURF-SAVER)
41	25122200/1	4	CUSCINETTO	BEARING	ROULEMENT	LAGER
42	25670005/1	2	RONDELLA SPESSORE 2,5 MM	WASHER THICKNEE 2.5 MM	RONDELLE EPAISSEUR 2,5 MM	SCHEIBE DICKE 2,5 MM
43	12001000/0	2	ANELLO ELASTICO	SNAP RING	ANNEAU RESSORT	SPRENGRING
44	82110250/1	2	ASS. COPRIDISCO RUOTA ANTERIORE (TC)	FRONT WHEEL COVERENS. ASS.Y (TC)	COUVRE DISQUE ROUE ANTERIEURE (TC)	VORRDERRAD DECKEL (TC)
	82110252/0	2	ASS. COPRIDISCO RUOTA ANTERIORE (TCP)	FRONT WHEEL COVERENS. ASS.Y (TCP)	COUVRE DISQUE ROUE ANTERIEURE (TCP)	VORRDERRAD DECKEL (TCP)
45	25430209/0	8	MOLLA AGGANCIO	SPRING	RESSORT	FEDER
46	12585100/0	2	GROWER	GROWER	GROWER	GROWER
47	12585100/0	2	GROWER	GROWER	GROWER	GROWER
48	22110230/0	2	COPRIMOZZO	HUB COVER	COUVRE MOYEU	RADNABE DECKEL
49	25950002/0	2	VALVOLA	VALVE	SOUPAPE	VENTIL

www.emc-motoculture.com

**TC102**

TC102 hy. TC122 hy.

**TCP102**

TCP102 hy. TCP122 hy.

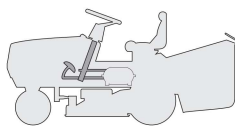
**COMANDO FRENO E COMANDO CAMBIO**  
**BRAKE AND GEARBOX CONTROLS**  
**COMMANDE FREIN ET BOITE DE VITESSE**  
**BREMSE UND WECHSEL ANTRIEB**

1999

**004M.0**

1 / 2

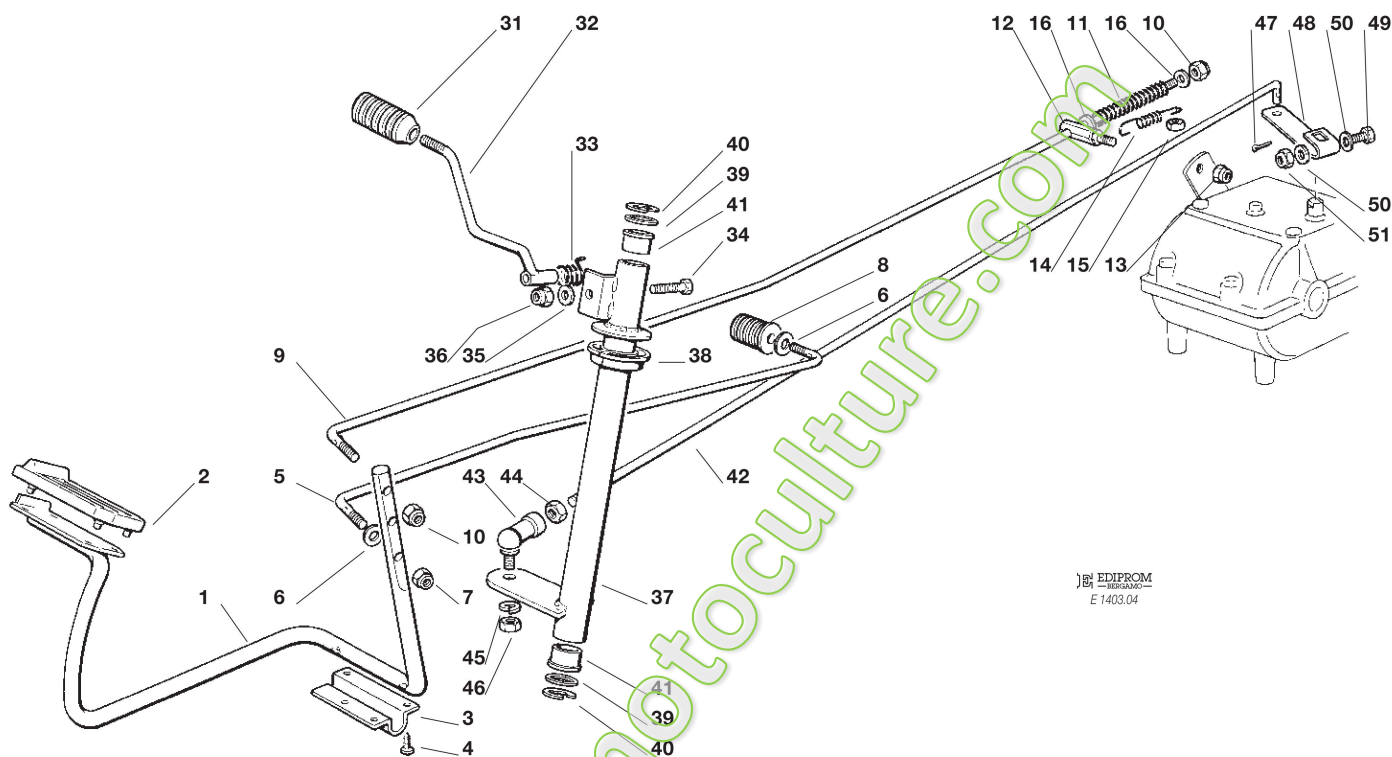
 EDIPROM  
 E 1403.04

N.	CODE	Q.TY	DESCRIZIONE	DESCRIPTION	DESCRIPTION	BESCHREIBUNG
1	82500001/0	1	PEDALE FRENO	BRAKE PEDAL	PEDALE DE FREIN	BREMSPEDAL
2	25110269/0	1	COPRISTAFFA	CLAMP COVER	COUVRE ETRIER	BRIDEDECKEL
3	25547012/0	1	PIASTRINA	PLATE	PLAQUE	PLATTE
4	12731601/0	4	VITE	SCREW	VIS	SCHRAUBE
5	25033005/0	1	ASTA	ROD	BARRE	STANGE
6	12523060/0	2	RONDELLA	WASHER	RONDELLE	SCHEIBE
7	12155000/0	1	DADO	NUT	ECROU	MUTTER
8	25394500/1	1	MANOPOLA FRENO	BRAKE KNOB	POIGNEE DE FREIN	BREMSEKNOPF
9	25033007/0	1	ASTA COMANDO FRENO	BRAKE CONTROL ROD	TIGE CONTROLE FREIN	BREMSE KONTROLLESATZ
10	12154510/0	2	DADO	NUT	ECROU	MUTTER
11	25430212/1	1	MOLLA	SPRING	RESSORT	FEDER
12	25510017/0	1	PERNO	PIN	PIVOT	BOLZEN
13	12155000/0	1	DADO	NUT	ECROU	MUTTER
14	25430213/0	1	MOLLA RICHIAMO FRENO	SPRING BRAKE	RESSORT FREIN	FEDER BREMSE
15	12155000/0	1	DADO	NUT	ECROU	MUTTER
16	12521330/0	2	RONDELLA	WASHER	RONDELLE	SCHEIBE
31	29394505/1	1	MANOPOLA CAMBIO	GEARBOX KNOB	POIGNEE BOITE DE VITESSE	WECHSELGETRIEBE
32	82318130/0	1	LEVA COMANDO CAMBIO	GEARSHIFT	LEVIER CHANGEMENT VITESSE	DEGETRIEBE HEBEL
33	25430225/0	1	MOLLA	SPRING	RESSORT	FEDER
34	12689515/0	1	VITE	SCREW	VIS	SCHRAUBE
35	12521330/0	1	RONDELLA	WASHER	RONDELLE	SCHEIBE
36	12154510/0	1	DADO	NUT	ECROU	MUTTER
37	82869005/0	1	TUBO COMANDO	SPEED DRIVE TUBE	TUBE COMMANDE CHANGE-MENT DE VITESSE	GAENGESCHALTUNG ROHR
38	25040602/0	2	BUSSOLA	BUSH	DOUILLE	BÜCHSE
39	25670006/0	2	RONDELLA	WASHER	RONDELLE	SCHEIBE
40	12001000/0	2	SEEGER	SEEGER	SEEGER	SEEGER
41	25040601/0	2	BUSSOLA	BUSH	DOUILLE	BÜCHSE



N.	CODE	Q.TY	DESCRIZIONE	DESCRIPTION	DESCRIPTION	BESCHREIBUNG
42	25033004/0	1	ASTA	ROD	BARRE	STANGE
43	22746601/0	1	SNODO M8	JOINT M8	JOINT M8	GELENK M8
44	12293200/0	1	DADO	NUT	ECROU	MUTTER
45	12583500/0	1	GROWER	GROWER	GROWER	GROWER
46	12293200/0	1	DADO	NUT	ECROU	MUTTER
47	12141418/0	1	COPPIGLIA	COTTER PIN	GOUPILLE	SPLIT
48	25318117/0	1	LEVA CAMBIO	GEARSHIFT	LEVIER CHANGEMENT DE VITESSE	GETRIEBE HEBEL
49	12689500/0	1	VITE	SCREW	VIS	SCHRAUBE
50	12521330/0	2	RONDELLA	WASHER	RONDELLE	SCHEIBE
51	12154510/0	1	DADO	NUT	ECROU	MUTTER

www.emc-motoculture.com

TC102

TC102 hy. TC122 hy.

TCP102

TCP102 hy. TCP122 hy.

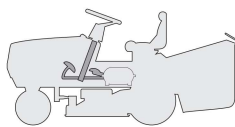

COMANDO TRASMISSIONE E FRENO  
DRIVE AND BRAKE CONTROLS  
COMMANDE TRANSMISSION ET FREIN  
GETRIEBE UND BREMSE ANTRIEB

1999

004Y.0

1 / 2

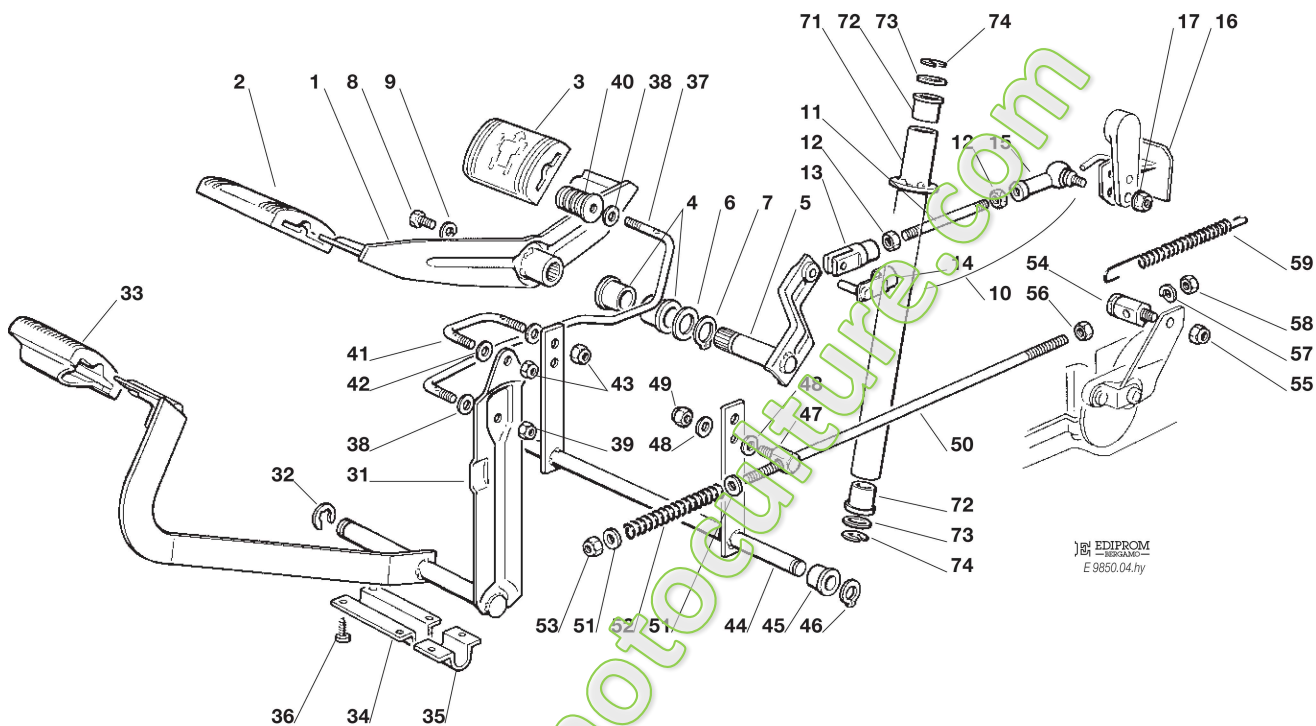

EDIPROM  
E 9850.04.hy

N.	CODE	Q.TY	DESCRIZIONE	DESCRIPTION	DESCRIPTION	BESCHREIBUNG
1	82500004/0	1	PEDALE AVANZAMENTO	DRIVE PEDAL	PEDALE TRANSMISSION	GETRIEBEPEDAL
2	25110265/0	1	COPRISTAFFA ANTERIORE	CLAMP COVER FRONT	COUVRE ETRIER AVANT	BRIDEDECKEL VORDE
3	25110266/0	1	COPRISTAFFA POSTERIORE	CLAMP COVER REAR	COUVRE ETRIER ARRIERE	BRIDEDECKEL HINTER
4	25034002/0	2	BRONZINA	BUSH	DOUILLE	BÜCHSE
5	82318145/0	1	LEVA	LEVER	LEVIER	HEBEL
6	22672153/0	1	RONDELLA	WASHER	RONDELLE	SCHEIBE
7	12609260/0	1	SEEGER	SEEGER	SEEGER	SEEGER
8	12792612/0	1	VITE	SCREW	VIS	SCHRAUBE
9	12583501/0	1	GROWER	GROWER	GROWER	GROWER
10	82820002/0	1	ASSIEME TIRANTE (11÷15)	ROD ASS.Y (11÷15)	ENS. BARRE (11÷15)	STANGE KOMPLETT (11÷15)
11	25598002/0	1	TIRANTE	ROD	BARRE	STANGE
12	12293200/0	2	DADO	NUT	ECROU	MUTTER
13	18399001/0	1	FORCELLA	FORK	FOURCHE	GABEL
14	18210201/0	1	CLIP	CLIP	CLIP	SPERRBOLZEN
15	22746602/0	1	SNODO	JOINT	JOINT	GELENK
16	82774217/1	1	STAFFA	BRACKET	ETRIER	BRIDE
17	12293201/0	1	DADO	NUT	ECROU	MUTTER
31	82500006/0	1	PEDALE FRENO	BRAKE PEDAL	PEDALE DE FREIN	BREMSPEDAL
32	12001000/0	1	ANELLO ELASTICO	SNAP RING	ANNEAU RESSORT	SPRENGRING
33	25110267/0	1	COPRISTAFFA	CLAMP COVER	COUVRE ETRIER	BRIDEDECKEL
34	25547039/0	1	PIASTRINA DESTRA	PLATE RIGHT	PLAQUE DROITE	PLATTE RECHTE
35	25547041/0	1	PIASTRINA SINISTRA	PLATE LEFT	PLAQUE GAUCHE	PLATTE LINKE
36	12731601/0	6	VITE	SCREW	VIS	SCHRAUBE
37	25033017/1	1	ASTA	ROD	BARRE	STANGE
38	12521350/0	2	RONDELLA	WASHER	RONDELLE	SCHEIBE
39	12155000/0	1	DADO	NUT	ECROU	MUTTER
40	25394500/1	1	MANOPOLA FRENO	BRAKE KNOB	POIGNEE DE FREIN	BREMSEKNOPF
41	25840004/0	1	ASTA COMANDO FRENO	BRAKE CONTROL ROD	TIGE CONTROLE FREIN	BREMSE KONTROLLESATZ
42	12521350/0	2	RONDELLA	WASHER	RONDELLE	SCHEIBE



N.	CODE	Q.TY	DESCRIZIONE	DESCRIPTION	DESCRIPTION	BESCHREIBUNG
43	12155000/0	2	DADO	NUT	ECROU	MUTTER
44	82000359/0	1	LEVE FRENO	BRAKE LEVERS	LEVIERS DE FREIN	BREMSEHEBELN
45	25040614/0	2	BUSSOLA	BUSH	DOUILLE	BÜCHSE
46	12608900/0	2	SEEGER	SEEGER	SEEGER	SEEGER
47	25510040/1	1	PERNO	PIN	PIVOT	BOLZEN
48	25670011/0	2	RONDELLA	WASHER	RONDELLE	SCHEIBE
49	12155000/0	1	DADO	NUT	ECROU	MUTTER
50	25033016/0	1	ASTA	ROD	BARRE	STANGE
51	12521350/0	2	RONDELLA	WASHER	RONDELLE	SCHEIBE
52	25430231/0	1	MOLLA	SPRING	RESSORT	FEDER
53	12155000/0	1	DADO	NUT	ECROU	MUTTER
54	25510041/0	1	PERNO	PIN	PIVOT	BOLZEN
55	12155000/0	1	DADO	NUT	ECROU	MUTTER
56	12193200/0	1	DADO	NUT	ECROU	MUTTER
57	12583500/0	1	GROWER	GROWER	GROWER	GROWER
58	12293200/0	1	DADO	NUT	ECROU	MUTTER
59	25430210/0	1	MOLLA	SPRING	RESSORT	FEDER
71	82869009/0	1	PIANTONE	STEERING COLOMN	TUBE DE DIRECTION	LENKSÄULE
72	25040601/0	2	BUSSOLA	BUSH	DOUILLE	BÜCHSE
73	25670006/0	2	RONDELLA	WASHER	RONDELLE	SCHEIBE
74	12001000/0	2	SEEGER	SEEGER	SEEGER	SEEGER

www.emc-motoculture.com

TC102

TC102 hy.

TC122 hy.

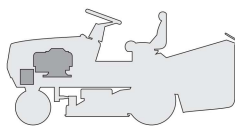

MOTORE

ENGINE

MOTEUR

MOTOR

12,5 - 13 HP B&amp;S

1999

005.0

1 / 1

TCP102

TCP102 hy.

TCP122 hy.

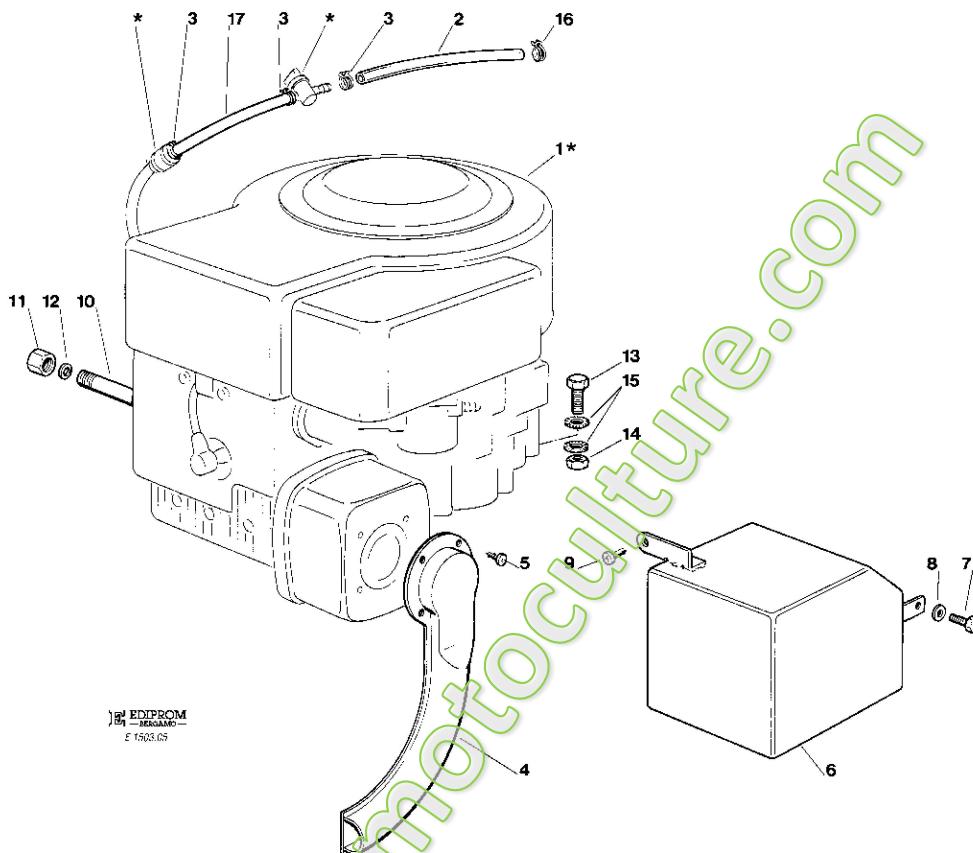

EDIPROM  
BERGAMO  
E 1505.05

N.	CODE	Q.TY	DESCRIZIONE	DESCRIPTION	DESCRIPTION	BESCHREIBUNG
1★	—	1	MOTORE	ENGINE	MOTEUR	MOTOR
2	25869016/0	1	TUBO COLLEGAMENTO	CONNECTING TUBE	TUBE DE CONNEXION	VERBINDUNGSRÖHR
3	18375051/1	3	FASCETTA	FAIR LED	FIXATION DE CABLE	KABELBEFESTIGUNG
4★	82640001/1	1	RACCORDO SCARICO	EXHAUST CONNECTION	CONNEXION ECHAPPEMENT	AUSPUFFANSCHLUSS
5	12735106/0	4	VITE	SCREW	VIS	SCHRAUBE
6	82598001/0	1	PROTEZIONE SILENZIATORE	MUFFLER PROTECTION	PROTECTION SILENCIEUX	AUSPUFFSCHUTZ
7	12735510/0	1	VITE	SCREW	VIS	SCHRAUBE
8	12540260/0	1	RONDELLA	WASHER	RONDELLE	SCHEIBE
9	12735104/0	1	VITE	SCREW	VIS	SCHRAUBE
10	25598050/0	1	PROLUNGA SCARICO OLIO	OIL DISCHARGE EXTENSION	EXTENSION RALLONGE DE DECH. HUILE	ÖL ENTLEERUNGSVERLÄN- GERUNG
11	18737849/0	1	TAPPO PER PROLUNGA	OIL CAP	BOUCHON HUILE	OELVERSCHLUSS
12	18401001/0	1	GUARNIZIONE	OIL SEAL	GARNITURE	DICHTUNG
13	12691100/0	4	VITE	SCREW	VIS	SCHRAUBE
14	12293200/0	1	DADO	NUT	ECROU	MUTTER
	12293201/0	3	DADO	NUT	ECROU	MUTTER
15	12540260/0	2	RONDELLA	WASHER	RONDELLE	SCHEIBE
16	18375053/0	1	FASCETTA	FAIR LED	FIXATION DE CABLE	KABELBEFESTIGUNG
17	25869006/0	1	TUBO COLLEGAMENTO	CONNECTING TUBE	TUBE DE CONNEXION	VERBINDUNGSRÖHR

PER LA SOSTITUZIONE DELLE PARTI CONTRASSEGNALE CON «★» RIVOLGERSI AL SERVIZIO ASSISTENZA DEL COSTRUTTORE DEL MOTORE.  
 TO REPLACE THE PARTS MARKED «★» SEEK ASSISTANCE FROM THE ENGINE MANUFACTURER'S AFTER SALES SERVICE.  
 POUR LE REMPLACEMENT DES PIÈCES MARQUÉES AVEC «★» S'ADRESSER AU SERVICE APRÈS VENTES DU CONSTRUCTEUR DU MOTEUR.  
 ZUM AUSTAUSCH DER MIT «★» GEKENNZEICHNETEN TEILE, WENDEN SIE SICH AN DEN KUNDENDIENST DES HERSTELLERS DES MOTOR.

TC102

TC102 hy.

TC122 hy.

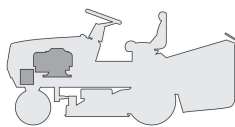

MOTORE

ENGINE

MOTEUR

MOTOR

16 - 18 HP B&amp;S

1999

005a.0

1 / 2

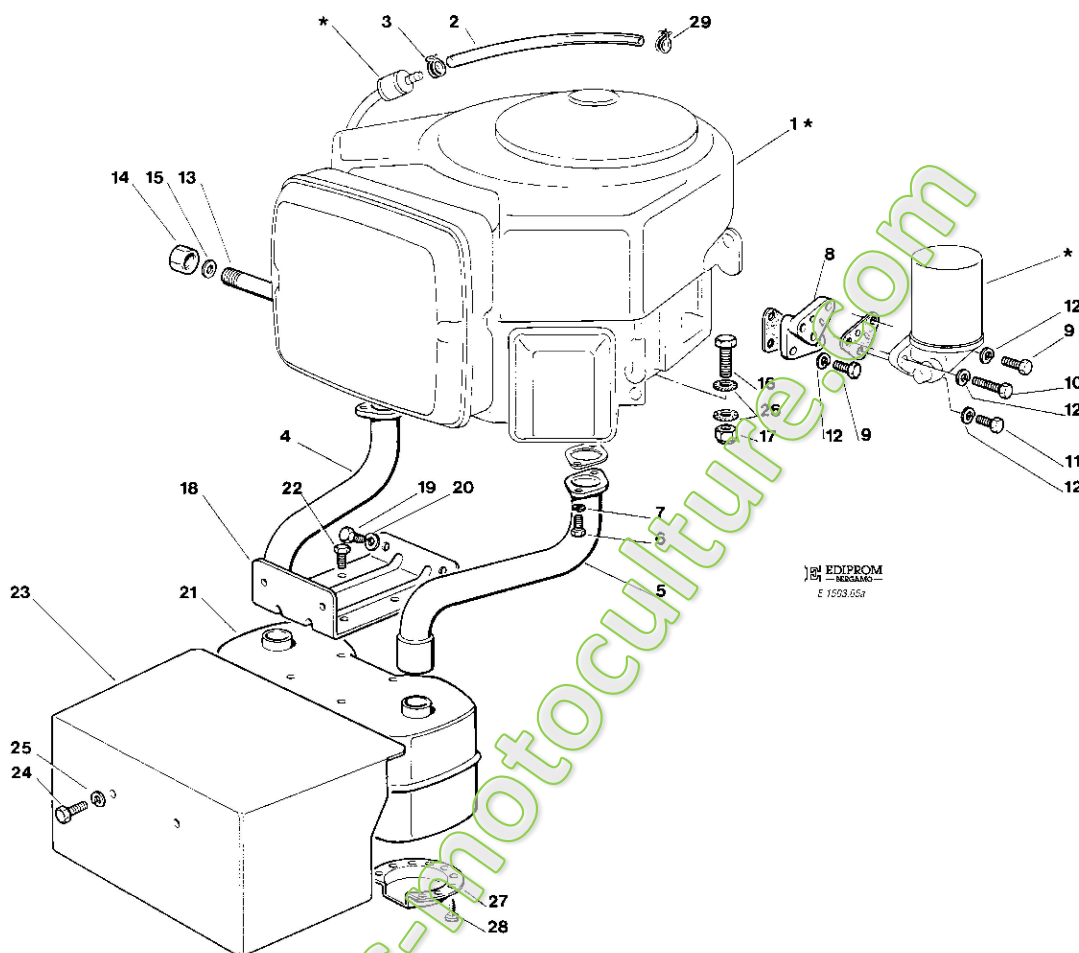
 EDIPROM  
 -REDAIRO-  
 E 1593.05a

N.	CODE	Q.TY	DESCRIZIONE	DESCRIPTION	DESCRIPTION	BESCHREIBUNG
1★	—	1	MOTORE	ENGINE	MOTEUR	MOTOR
2	25869017/0	1	TUBO COLLEGAMENTO	CONNECTING TUBE	TUBE DE CONNEXION	VERBINDUNGSRÖHR
3	18375051/1	1	FASCETTA	FAIR LED	FIXATION DE CABLE	KABELBEFESTIGUNG
4★	18738202/0	1	TUBO RACCORDO SCARICO DX	EXHAUST RIGHT CONNECTING TUBE	TUBE DE CONNEXION DROIT POUR ECHAPP.	RECHTES VERBINDUNGS- RÖHR FÜR ABGASUNG
5★	18738203/0	1	TUBO RACCORDO SCARICO SX	EXHAUST LEFT CONNECTING TUBE	TUBE DE CONNEXION GAUCHE POUR ECHAPP.	LINKES VERBINDUNGS- RÖHR FÜR ABGASUNG
6	12793101/0	4	VITE	SCREW	VIS	SCHRAUBE
7	12583500/0	4	GROWER	GROWER	GROWER	GROWER
8	25785095/0	1	SUPPORTO FILTRO	FILTER SUPPORT	SUPPORTE DU FILTRE	WECHSELFILTER HALTER
9	12791400/0	3	VITE	SCREW	VIS	SCHRAUBE
10	12689515/0	1	VITE	SCREW	VIS	SCHRAUBE
11	12791213/0	1	VITE	SCREW	VIS	SCHRAUBE
12	12582100/0	5	GROWER	GROWER	GROWER	GROWER
13	25598050/0	1	PROLUNGA SCARICO OLIO	OIL DISCHARGE EXTENSION	EXTENSION RALLONGE DE DECH. HUILE	ÖL ENTLERUNGSVERLÄN- GERUNG
14	18737849/0	1	TAPPO PROLUNGA	OIL CAP	BOUCHON HUILE	OELVERSCHLUSS
15	18401001/0	1	GUARNIZIONE	OIL SEAL	GARNITURE	DICHTUNG
16	12691100/0	4	VITE	SCREW	VIS	SCHRAUBE
17	12293201/0	3	DADO	NUT	ECROU	MUTTER
	12293200/0	1	DADO	NUT	ECROU	MUTTER
18	82785093/0	1	PROTEZIONE SILENZIATORE	MUFFLER PROTECTION	PROTECTION SILENCIEUX	AUSPUFFSCHUTZ
19	12793102/0	2	VITE	SCREW	VIS	SCHRAUBE
20	12583500/0	2	GROWER	GROWER	GROWER	GROWER
21★	18716131/1	1	SILENZIATORE COMPLETO DI DEFLETTORE	MUFFLER WITH DEFLECTOR	SILENCEUX AVEC DEFLECTEUR	AUSPUFF MIT DEFLEKTOR
22	12735107/0	4	VITE	SCREW	VIS	SCHRAUBE
23	82598005/1	1	PROTEZIONE	GUARD	PROTECTION	SCHUTZE
24	12792610/0	2	VITE	SCREW	VIS	SCHRAUBE
25	12583500/0	2	GROWER	GROWER	GROWER	GROWER
26	12540260/0	2	RONDELLA	WASHER	RONDELLE	SCHEIBE



N.	CODE	Q.TY	DESCRIZIONE	DESCRIPTION	DESCRIPTION	BESCHREIBUNG
27	18310005/0	1	DEFLETTORE	DEFLECTOR	DEFLECTEUR	DEFLEKTOR
28	12735106/0	4	VITE	SCREW	VIS	SCHRAUBE
29	18375053/0	1	FASCETTA	FAIR LED	FIXATION DE CABLE	KABELBEFESTIGUNG

PER LA SOSTITUZIONE DELLE PARTI CONTRASSEGNALE CON «\*» RIVOLGERSI AL SERVIZIO ASSISTENZA DEL COSTRUTTORE DEL MOTORE.  
 TO REPLACE THE PARTS MARKED «\*» SEEK ASSISTANCE FROM THE ENGINE MANUFACTURER'S AFTER SALES SERVICE.  
 POUR LE REMPLACEMENT DES PIÈCES MARQUÉES AVEC «\*» S'ADRESSER AU SERVICE APRÈS VENTES DU CONSTRUCTEUR DU MOTEUR.  
 ZUM AUSTAUSCH DER MIT «\*» GEKENNZEICHNETEN TEILE, WENDEN SIE SICH AN DEN KUNDENDIENST DES HERSTELLERS DES MOTOR.

www.emc-motoculture.com

TC102

TC102 hy.

TC122 hy.

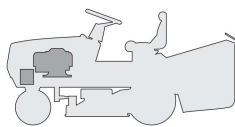

MOTORE

ENGINE

MOTEUR

MOTOR

15,5 HP B&amp;S

1999

005b.0

1 / 1

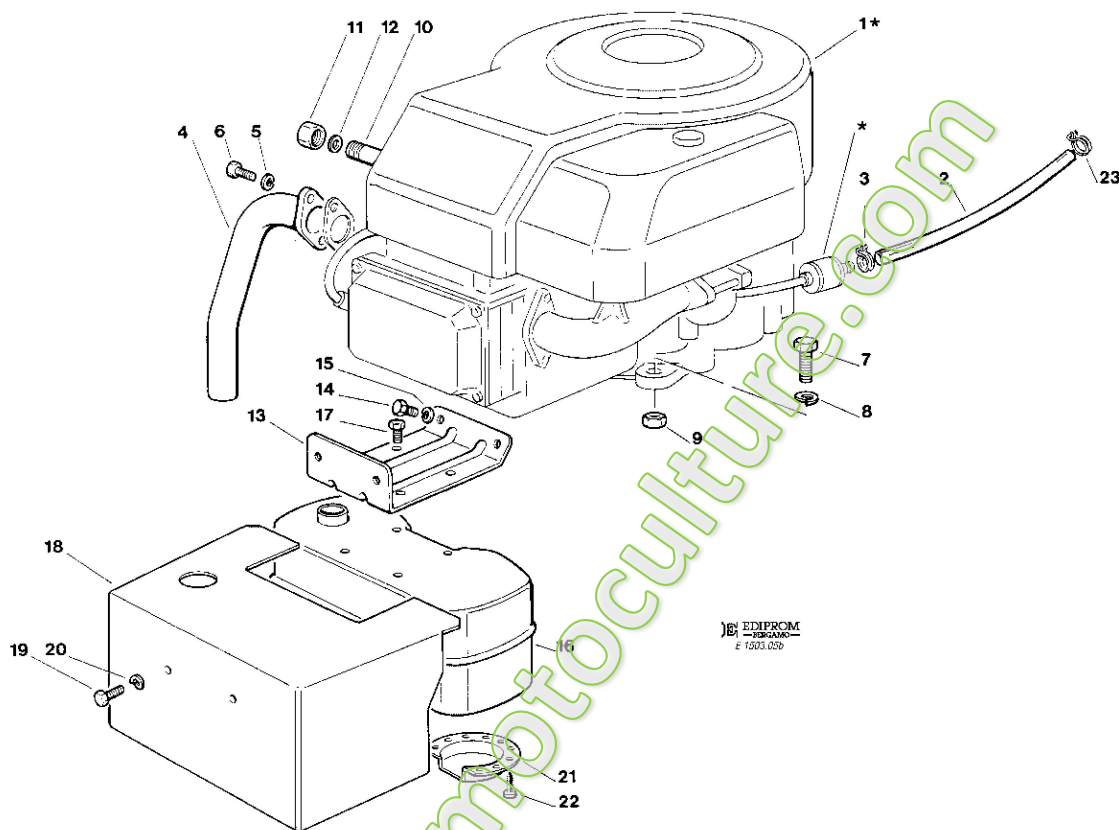

EDIPROM  
—SERGAMO—  
E 1503.020

N.	CODE	Q.TY	DESCRIZIONE	DESCRIPTION	DESCRIPTION	BESCHREIBUNG
1★	—	1	MOTORE	ENGINE	MOTEUR	MOTOR
2	25869016/0	1	TUBO COLLEGAMENTO	CONNECTING TUBE	TUBE DE CONNEXION	VERBINDUNGSRÖHR
3	18375051/1	1	FASCETTA	FAIR LED	FIXATION DE CABLE	KABELBEFESTIGUNG
4★	18738206/0	1	TUBO RACCORDO SCARICO	EXHAUST CONNECTING TUBE	TUBE DE CONNEXION POUR ECHAPPEMENT	VERBINDUNGSRÖHR FÜR ABGASUNG
5	12583500/0	2	GROWER	GROWER	GROWER	GROWER
6	12735530/0	2	VITE	SCREW	VIS	SCHRAUBE
7	12691100/0	4	VITE	SCREW	VIS	SCHRAUBE
8	12540260/0	4	GROWER	GROWER	GROWER	GROWER
9	12293200/0	1	DADO	NUT	ECROU	MUTTER
10	25598050/0	1	PROLUNGA SCARICO OLIO	OIL DISCHARGE EXTENSION	EXTENSION RALLONGE DE DECH. HUILE	ÖL ENTLERUNGSVERLÄEN- GERUNG
11	18737849/0	1	TAPPO PROLUNGA	OIL CAP	BOUCHON HUILE	OELVERSCHLUSS
12	18401001/0	1	GUARNIZIONE	OIL SEAL	GARNITURE	DICHTUNG
13	82785093/0	2	PROTEZIONE SILENZIATORE	MUFFLER PROTECTION	PROTECTION SILENCIEUX	AUSPUFFSCHUTZ
14	12793102/0	1	VITE	SCREW	VIS	SCHRAUBE
15	12583500/0	2	GROWER	GROWER	GROWER	GROWER
16	18716132/0	1	SILENZIATORE COMPLETO DI DEFLETTORE	MUFFLER WITH DEFLECTOR	SILENCEUX AVEC DEFLECTEUR	AUSPUFF MIT DEFLEKTOR
17	12735107/0	4	VITE	SCREW	VIS	SCHRAUBE
18	82598009/1	1	PROTEZIONE	GUARD	PROTECTION	SCHUTZE
19	12792611/0	2	VITE	SCREW	VIS	SCHRAUBE
20	12583500/0	2	GROWER	GROWER	GROWER	GROWER
21	18310005/0	1	DEFLETTORE	DEFLECTOR	DEFLECTEUR	DEFLEKTOR
22	12735106/0	4	VITE	SCREW	VIS	SCHRAUBE
23	18375053/0	1	FASCETTA	FAIR LED	FIXATION DE CABLE	KABELBEFESTIGUNG

PER LA SOSTITUZIONE DELLE PARTI CONTRASSEGNALE CON «★» RIVOLGERSI AL SERVIZIO ASSISTENZA DEL COSTRUTTORE DEL MOTORE.  
 TO REPLACE THE PARTS MARKED «★» SEEK ASSISTANCE FROM THE ENGINE MANUFACTURER'S AFTER SALES SERVICE.  
 POUR LE REMPLACEMENT DES PIÈCES MARQUÉES AVEC «★» S'ADRESSER AU SERVICE APRÈS VENTES DU CONSTRUCTEUR DU MOTEUR.  
 ZUM AUSTAUSCH DER MIT «★» GEKENNZEICHNETEN TEILE, WENDEN SIE SICH AN DEN KUNDENDIENST DES HERSTELLERS DES MOTOR.

TC102	TC102 hy.	TC122 hy.
TCP102	TCP102 hy.	<b>TCP122 hy.</b>

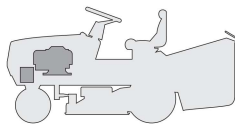

**MOTORE  
ENGINE  
MOTEUR  
MOTOR  
20 HP B&S**

1999  
**005c.0**  
1 / 2

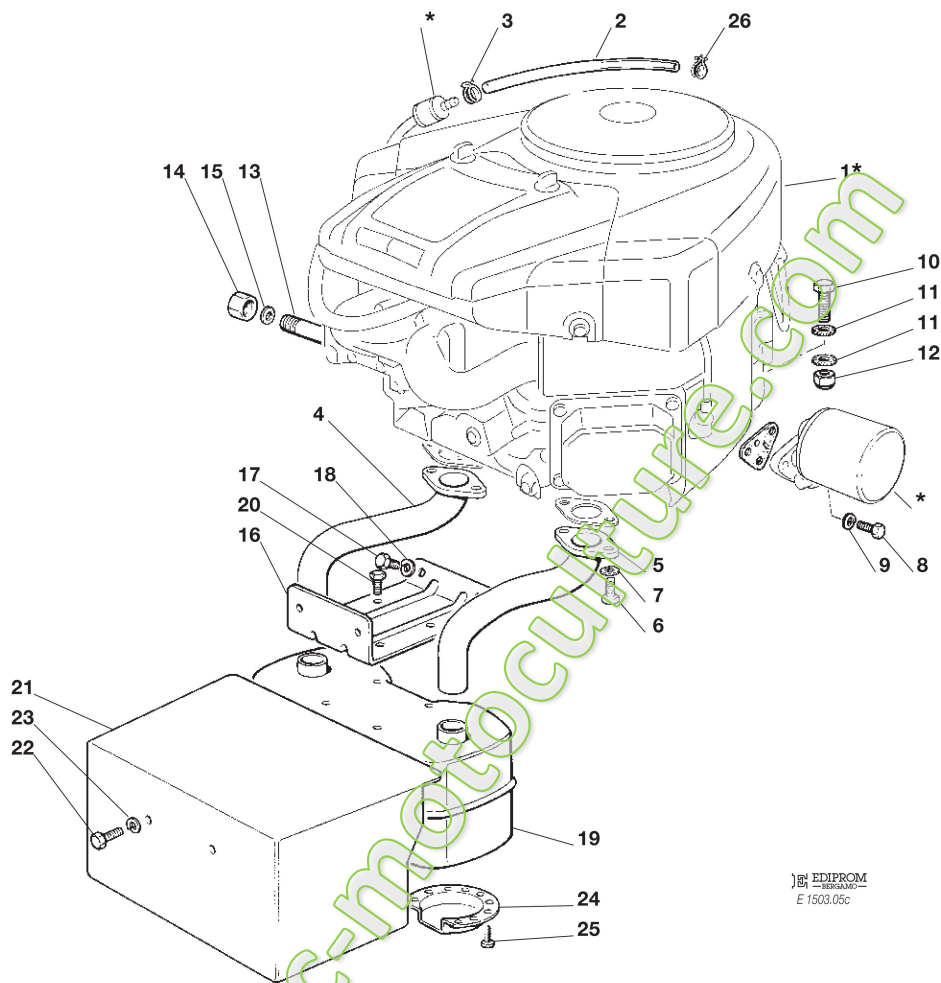

EDIPROM  
E 1503,05c

N.	CODE	Q.TY	DESCRIZIONE	DESCRIPTION	DESCRIPTION	BESCHREIBUNG
1★	—	1	MOTORE	ENGINE	MOTEUR	MOTOR
2	25869016/0	1	TUBO COLLEGAMENTO	CONNECTING TUBE	TUBE DE CONNEXION	VERBINDUNGSRÖHR
3	18375051/1	1	FASCETTA	FAIR LED	FIXATION DE CABLE	KABELBEFESTIGUNG
4★	18738214/0	1	TUBO RACCORDO SCARICO DX	EXHAUST RIGHT CONNECTING TUBE	TUBE DE CONNEXION DROIT POUR ECHAPP.	RECHTES VERBINDUNGS- RÖHR FÜR ABGASUNG
5★	18738215/0	1	TUBO RACCORDO SCARICO SX	EXHAUST LEFT CONNECTING TUBE	TUBE DE CONNEXION GAUCHE POUR ECHAPP.	LINKES VERBINDUNGS- RÖHR FÜR ABGASUNG
6	12735530/0	4	VITE	SCREW	VIS	SCHRAUBE
7	12583500/0	4	GROWER	GROWER	GROWER	GROWER
8	12791400/0	3	VITE	SCREW	VIS	SCHRAUBE
9	12582100/0	3	GROWER	GROWER	GROWER	GROWER
10	12691100/0	4	VITE	SCREW	VIS	SCHRAUBE
11	12540260/0	2	RONDELLA	WASHER	RONDELLE	SCHEIBE
12	12293201/0	3	DADO	NUT	ECROU	MUTTER
	12293200/0	1	DADO	NUT	ECROU	MUTTER
13	25598050/0	1	PROLUNGA SCARICO OLIO	OIL DISCHARGE EXTENSION	EXTENSION RALLONGE DE DECH. HUILE	ÖL ENTLERUNGSVERLÄEN- GERUNG
14	18737849/0	1	TAPPO PROLUNGA	OIL CAP	BOUCHON HUILE	OELVERSCHLUSS
15	18401001/0	1	GUARNIZIONE	OIL SEAL	GARNITURE	DICHTUNG
16	82785093/0	1	PROTEZIONE SILENZIATORE	MUFFLER PROTECTION	PROTECTION SILENCIEUX	AUSPUFFSCHUTZ
17	12793102/0	2	VITE	SCREW	VIS	SCHRAUBE
18	12583500/0	2	GROWER	GROWER	GROWER	GROWER
19★	18716131/1	1	SILENZIATORE COMPLETO DI DEFLETTORE	MUFFLER WITH DEFLECTOR	SILENCEUX AVEC DEFLECTEUR	AUSPUFF MIT DEFLEKTOR
20	12735107/0	4	VITE	SCREW	VIS	SCHRAUBE
21	82598005/1	1	PROTEZIONE	GUARD	PROTECTION	SCHUTZE
22	12792610/0	2	VITE	SCREW	VIS	SCHRAUBE
23	12583500/0	2	GROWER	GROWER	GROWER	GROWER
24	18310005/0	1	DEFLETTORE	DEFLECTOR	DEFLECTEUR	DEFLEKTOR
25	12735106/0	4	VITE	SCREW	VIS	SCHRAUBE
26	18375053/0	1	FASCETTA	FAIR LED	FIXATION DE CABLE	KABELBEFESTIGUNG



N.	CODE	Q.TY	DESCRIZIONE	DESCRIPTION	DESCRIPTION	BESCHREIBUNG
----	------	------	-------------	-------------	-------------	--------------

PER LA SOSTITUZIONE DELLE PARTI CONTRASSEGNAE CON «\*» RIVOLGERSI AL SERVIZIO ASSISTENZA DEL COSTRUTTORE DEL MOTORE.  
 TO REPLACE THE PARTS MARKED «\*» SEEK ASSISTANCE FROM THE ENGINE MANUFACTURER'S AFTER SALES SERVICE.  
 POUR LE REMPLACEMENT DES PIÈCES MARQUÉES AVEC «\*» S'ADRESSER AU SERVICE APRÈS VENTES DU CONSTRUCTEUR DU MOTEUR.  
 ZUM AUSTAUSCH DER MIT «\*» GEKENNZEICHNETEN TEILE, WENDEN SIE SICH AN DEN KUNDENDIENST DES HERSTELLERS DES MOTOR.

[www.emc-motoculture.com](http://www.emc-motoculture.com)

TC102

TC102 hy.

TC122 hy.

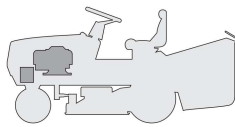

MOTORE  
ENGINE  
MOTEUR  
MOTOR  
13 HP TECUMSEH

1999

005d.0

1 / 2

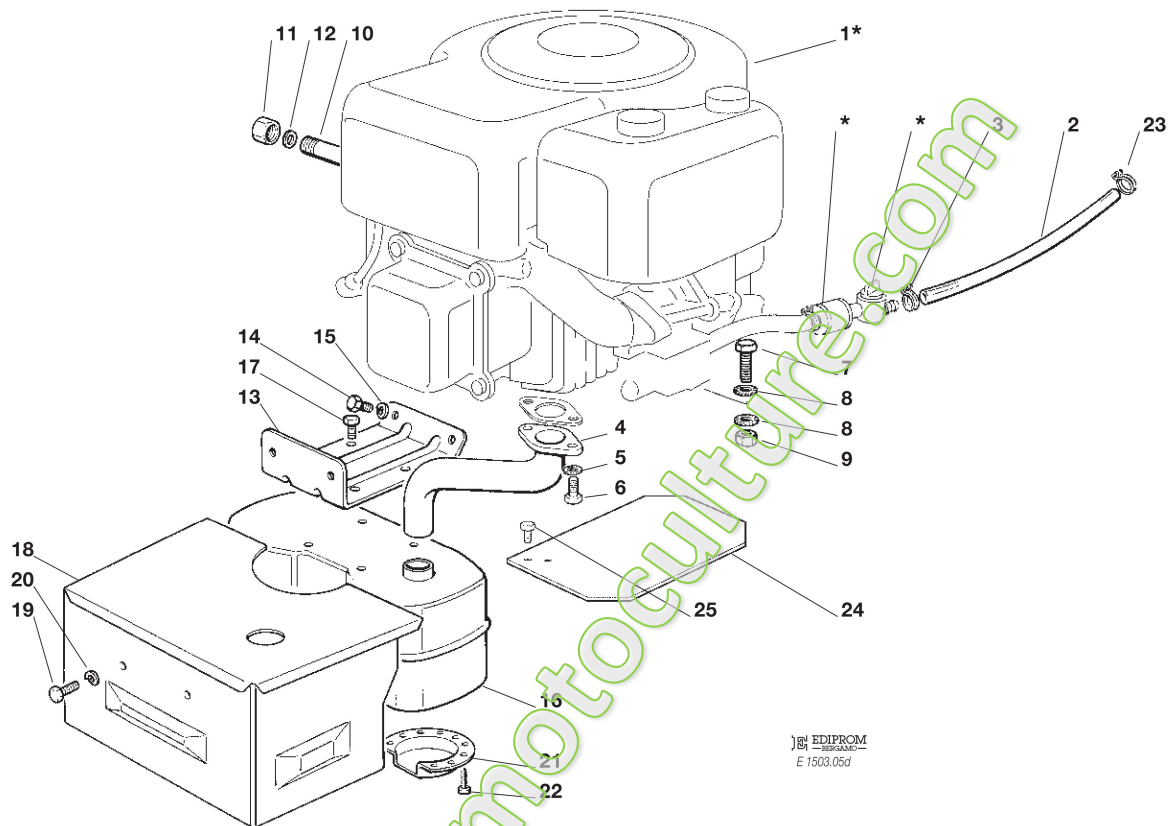

EDIPROM  
E 1503.05d

N.	CODE	Q.TY	DESCRIZIONE	DESCRIPTION	DESCRIPTION	BESCHREIBUNG
1★	—	1	MOTORE	ENGINE	MOTEUR	MOTOR
2	25869027/0	1	TUBO COLLEGAMENTO	CONNECTING TUBE	TUBE DE CONNEXION	VERBINDUNGSRÖHR
3	18375051/1	1	FASCETTA	FAIR LED	FIXATION DE CABLE	KABELBEFESTIGUNG
4★	18738211/0	1	TUBO RACCORDO SCARICO	EXHAUST CONNECTING TUBE	TUBE DE CONNEXION POUR ECHAPPEMENT	VERBINDUNGSRÖHR FÜR ABGASUNG
5	12583500/0	2	GROWER	GROWER	GROWER	GROWER
6	12735530/0	2	VITE	SCREW	VIS	SCHRAUBE
7	12691100/0	4	VITE	SCREW	VIS	SCHRAUBE
8	12540260/0	4	RONDELLA	WASHER	RONDELLE	SCHEIBE
9	12293200/0	1	DADO	NUT	ECROU	MUTTER
10	25598050/0	1	PROLUNGA SCARICO OLIO	OIL DISCHARGE EXTENSION	EXTENSION RALLONGE DE DECH. HUILE	ÖL ENTLEERUNGSVERLÄNGERUNG
11	18737849/0	1	TAPPO PROLUNGA	OIL CAP	BOUCHON HUILE	OELVERSCHLUSS
12	18401001/0	1	GUARNIZIONE	OIL SEAL	GARNITURE	DICHTUNG
13	82785093/0	1	SUPPORTO SILENZIATORE	MUFFLER SUPPORT	SUPPORT SILENCIEUX	AUSPUFFHALTERSATZ
14	12793102/0	2	VITE	SCREW	VIS	SCHRAUBE
15	12583500/0	2	GROWER	GROWER	GROWER	GROWER
16	18716132/0	1	SILENZIATORE COMPLETO DI DEFLETTORE	MUFFLER WITH DEFLECTOR	SILENCEUX AVEC DEFLECTEUR	AUSPUFF MIT DEFLEKTOR
17	12735107/0	4	VITE	SCREW	VIS	SCHRAUBE
18	82598017/0	1	PROTEZIONE	GUARD	PROTECTION	SCHUTZE
19	12792611/0	2	VITE	SCREW	VIS	SCHRAUBE
20	12583500/0	2	GROWER	GROWER	GROWER	GROWER
21	18310005/0	1	DEFLETTORE	DEFLECTOR	DEFLECTEUR	DEFLEKTOR
22	12735106/0	4	VITE	SCREW	VIS	SCHRAUBE
23	18375053/0	1	FASCETTA	FAIR LED	FIXATION DE CABLE	KABELBEFESTIGUNG
24	25600031/0	1	PROTEZIONE SILENZIATORE	MUFFLER PROTECTION	PROTECTION SILENCIEUX	AUSPUFFSCHUTZ
25	12735106/0	2	VITE	SCREW	VIS	SCHRAUBE



N.	CODE	Q.TY	DESCRIZIONE	DESCRIPTION	DESCRIPTION	BESCHREIBUNG
----	------	------	-------------	-------------	-------------	--------------

PER LA SOSTITUZIONE DELLE PARTI CONTRASSEGNALE CON «\*» RIVOLGERSI AL SERVIZIO ASSISTENZA DEL COSTRUTTORE DEL MOTORE.  
 TO REPLACE THE PARTS MARKED «\*» SEEK ASSISTANCE FROM THE ENGINE MANUFACTURER'S AFTER SALES SERVICE.  
 POUR LE REMPLACEMENT DES PIÈCES MARQUÉES AVEC «\*» S'ADRESSER AU SERVICE APRÈS VENTES DU CONSTRUCTEUR DU MOTEUR.  
 ZUM AUSTAUSCH DER MIT «\*» GEKENNZEICHNETEN TEILE, WENDEN SIE SICH AN DEN KUNDENDIENST DES HERSTELLERS DES MOTOR.

[www.emc-motoculture.com](http://www.emc-motoculture.com)

TC102

TC102 hy.

TC122 hy.

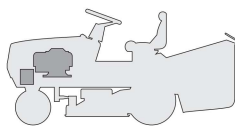

MOTORE

ENGINE

MOTEUR

MOTOR

15 HP TECUMSEH

1999

005e.0

1 / 2

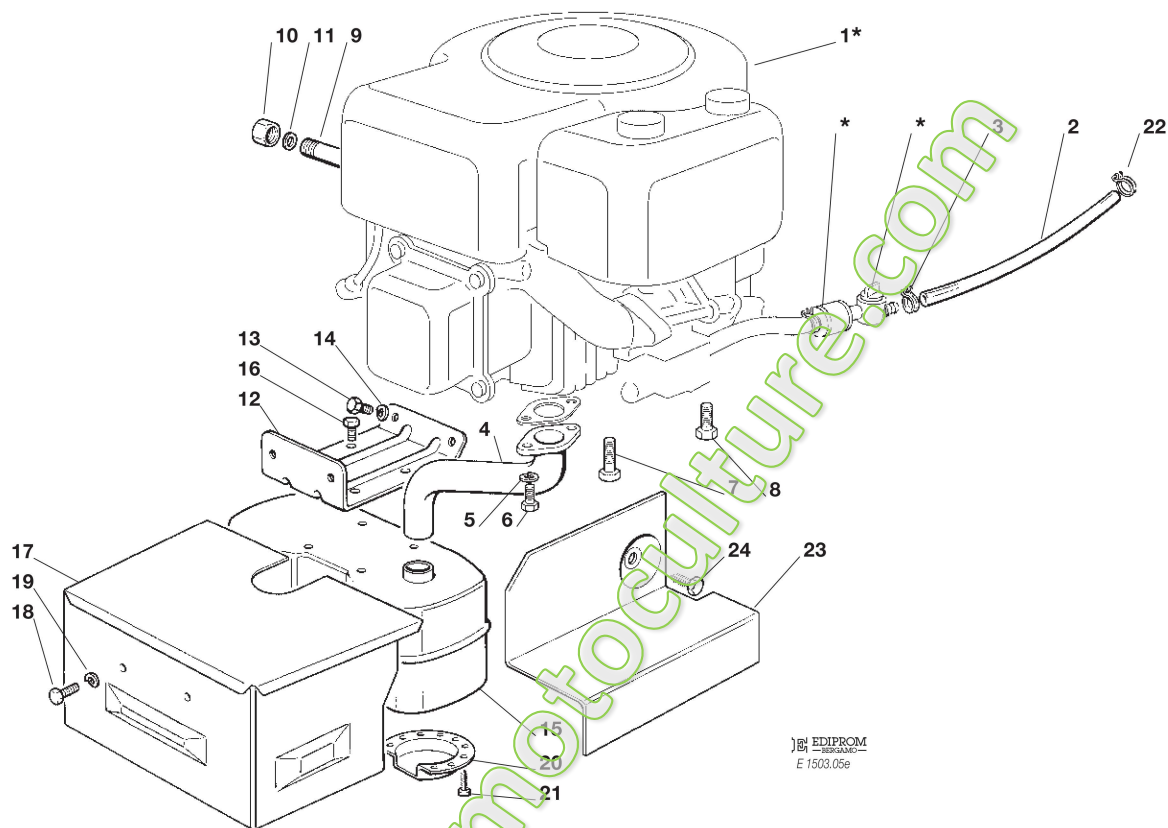

EDIPROM  
E 1503.05e

N.	CODE	Q.TY	DESCRIZIONE	DESCRIPTION	DESCRIPTION	BESCHREIBUNG
1★	—	1	MOTORE	ENGINE	MOTEUR	MOTOR
2	25869027/0	1	TUBO COLLEGAMENTO	CONNECTING TUBE	TUBE DE CONNEXION	VERBINDUNGSRÖHR
3	18375051/1	1	FASCETTA	FAIR LED	FIXATION DE CABLE	KABELBEFESTIGUNG
4★	18738212/0	1	TUBO RACCORDO SCARICO	EXHAUST CONNECTING TUBE	TUBE DE CONNEXION POUR ECHAPPEMENT	VERBINDUNGSRÖHR FÜR ABGASUNG
5	12583500/0	2	GROWER	GROWER	GROWER	GROWER
6	12735530/0	2	VITE	SCREW	VIS	SCHRAUBE
7	12735109/0	3	VITE	SCREW	VIS	SCHRAUBE
8	12735108/0	1	VITE	SCREW	VIS	SCHRAUBE
9	25598050/0	1	PROLUNGA SCARICO OLIO	OIL DISCHARGE EXTENSION	EXTENSION RALLONGE DE DECH. HUILE	ÖL ENTLERUNGSVERLÄNGERUNG
10	18737849/0	1	TAPPO PROLUNGA	OIL CAP	BOUCHON HUILE	OELVERSCHLUSS
11	18401001/0	1	GUARNIZIONE	OIL SEAL	GARNITURE	DICHTUNG
12	82785093/0	1	SUPPORTO SILENZIATORE	MUFFLER SUPPORT	SUPPORT SILENCIEUX	AUSPUFFHALTERSATZ
13	12793102/0	2	VITE	SCREW	VIS	SCHRAUBE
14	12583500/0	2	GROWER	GROWER	GROWER	GROWER
15	18716132/0	1	SILENZIATORE COMPLETO DI DEFLETTORE	MUFFLER WITH DEFLECTOR	SILENCIEUX AVEC DEFLECTEUR	AUSPUFF MIT DEFLEKTOR
16	12735107/0	4	VITE	SCREW	VIS	SCHRAUBE
17	82598019/0	1	PROTEZIONE	GUARD	PROTECTION	SCHUTZE
18	12792611/0	2	VITE	SCREW	VIS	SCHRAUBE
19	12583500/0	2	GROWER	GROWER	GROWER	GROWER
20	18310005/0	1	DEFLETTORE	DEFLECTOR	DEFLECTEUR	DEFLEKTOR
21	12735106/0	4	VITE	SCREW	VIS	SCHRAUBE
22	18375053/0	1	FASCETTA	FAIR LED	FIXATION DE CABLE	KABELBEFESTIGUNG
23	25600038/0	1	PROTEZIONE SILENZIATORE	MUFFLER PROTECTION	PROTECTION SILENCIEUX	AUSPUFFSCHUTZ
24	12734995/0	1	VITE	SCREW	VIS	SCHRAUBE

PER LA SOSTITUZIONE DELLE PARTI CONTRASSEGNALE CON «★» RIVOLGERSI AL SERVIZIO ASSISTENZA DEL COSTRUTTORE DEL MOTORE.  
TO REPLACE THE PARTS MARKED «★» SEEK ASSISTANCE FROM THE ENGINE MANUFACTURER'S AFTER SALES SERVICE.



N.	CODE	Q.TY	DESCRIZIONE	DESCRIPTION	DESCRIPTION	BESCHREIBUNG
----	------	------	-------------	-------------	-------------	--------------

POUR LE REMPLACEMENT DES PIÈCES MARQUÉES AVEC «★» S'ADRESSER AU SERVICE APRÈS VENTES DU CONSTRUCTEUR DU MOTEUR.  
 ZUM AUSTAUSCH DER MIT «★» GEKENNZEICHNETEN TEILE, WENDEN SIE SICH AN DEN KUNDENDIENST DES HERSTELLERS DES MOTOR.

[www.emc-motoculture.com](http://www.emc-motoculture.com)

TC102

TC102 hy. TC122 hy.

TCP102

TCP102 hy. TCP122 hy.

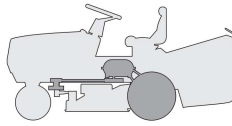

TRASMISSIONE  
TRANSMISSION  
TRANSMISSION  
GETRIEBE

1999

006M.0

1 / 2

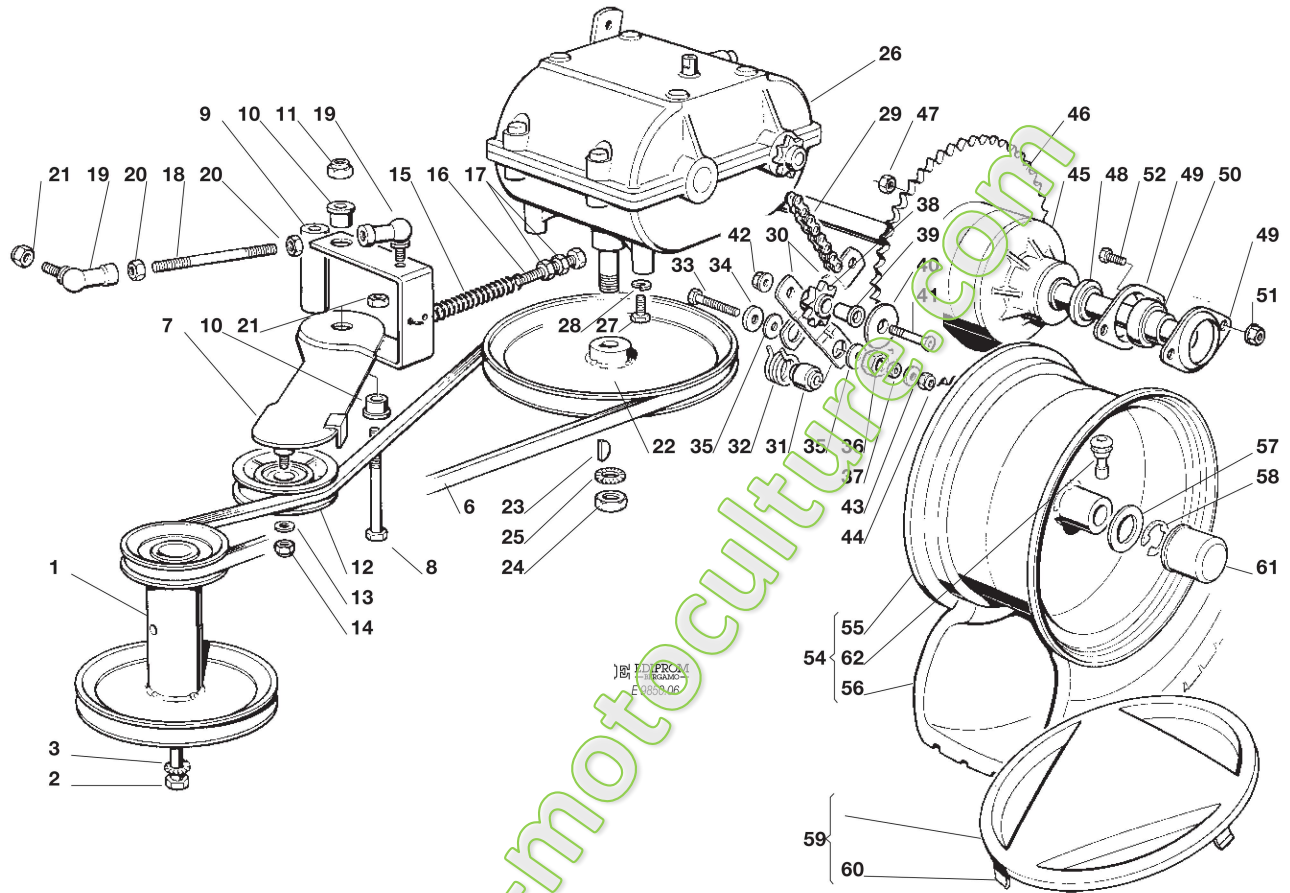

N.	CODE	Q.TY	DESCRIZIONE	DESCRIPTION	DESCRIPTION	BESCHREIBUNG
1	25601552/2	1	PULEGGIA MOTORE	ENGINE PULLEY	POULIE MOTEUR	RIEMENSCHLEIBE
2	12737310/0	1	VITE	SCREW	VIS	SCHRAUBE
3	12543000/0	1	RONDELLA	WASHER	RONDELLE	SCHLEIBE
6	35061501/0	1	CINGHIA	BELT	COURROIE	RIEMEN
7	82318111/1	1	LEVA GALOPPINO	TIGHTENER LEVER	LEVIER GALOPIN	LEIT ROLLE
8	12692080/0	1	VITE	SCREW	VIS	SCHRAUBE
9	25160008/0	1	DISTANZIALE	SPACER	ENTRETOISE	ENTFERNUNGSSTUECK
10	25038002/0	2	BOCCOLA	BUSHING	DOUILLE	BÜCHSE
11	12155000/0	1	DADO	NUT	ECROU	MUTTER
12	25601554/0	1	PULEGGIA	PULLEY	POULIE	RIEMENSCHLEIBE
13	12523060/0	1	RONDELLA	WASHER	RONDELLE	SCHLEIBE
14	12155000/0	1	DADO	NUT	ECROU	MUTTER
15	25430219/0	1	MOLLA	SPRING	RESSORT	FEDER
16	22943005/0	1	VITE	SCREW	VIS	SCHRAUBE
17	12293200/0	2	DADO	NUT	ECROU	MUTTER
18	25598002/0	1	PRIGIONIERO	STUD SCREW	PRISONNIER	STIFTSCHLEIBE
19	22746601/0	2	SNODO M8	JOINT M8	JOINT M8	GELENK M8
20	12293200/0	2	DADO	NUT	ECROU	MUTTER
21	12155000/0	2	DADO	NUT	ECROU	MUTTER
22	82601501/0	1	PULEGGIA	PULLEY	POULIE	RIEMENSCHLEIBE
23	12138810/0	1	LINGUETTA	KEY	CLAVETTE	KEIL
24	12361010/0	1	DADO	NUT	ECROU	MUTTER
25	12540280/0	1	RONDELLA	WASHER	RONDELLE	SCHLEIBE
26*	18159002/0	1	CAMBIO	GEAR BOX	BOITE DE VITESSE	GETRIEBE
27	12735530/0	4	VITE	SCREW	VIS	SCHRAUBE
28	12583500/0	4	GROWER	GROWER	GROWER	GROWER
29	15189001/0	1	CATENA	CHAIN	CHAINE	KETTE
30	25318122/0	2	LEVA FLOTTANTE	FLOATING LEVER	LEVIER	HEBEL
31	25040607/0	1	BUSSOLA	BUSH	DOUILLE	BÜCHSE
32	25430207/0	1	MOLLA	SPRING	RESSORT	FEDER
33	25943002/0	1	VITE	SCREW	VIS	SCHRAUBE



N.	CODE	Q.TY	DESCRIZIONE	DESCRIPTION	DESCRIPTION	BESCHREIBUNG
34	12523070/0	1	ROSETTA	WASHER	RONDELLE	SCHEIBE
35	22672152/0	2	RONDELLA ANTIFRIZIONE	WASHER	RONDELLE	SCHEIBE
36	25160006/0	1	DISTANZIALE	SPACER	ENTRETOISE	ENTFERNUNGSSTÜCK
37	12293200/0	1	DADO	NUT	ECROU	MUTTER
38	25570001/0	2	PIGNONE	PINION	PIGNON	RITZEL
39	25040608/0	2	BUSSOLA	BUSH	DOUILLE	BUCHSE
40	25670009/0	2	RONDELLA	WASHER	RONDELLE	SCHEIBE
41	12882020/0	2	VITE	SCREW	VIS	SCHRAUBE
42	12155000/0	2	DADO	NUT	ECROU	MUTTER
43	12524010/0	1	ROSETTA	WASHER	RONDELLE	SCHEIBE
44	12155000/0	1	DADO	NUT	ECROU	MUTTER
45*	25140201/0	1	DIFFERENZIALE	DIFFERENTIAL GEAR	DIFFERENTIEL	DIFFERENTIAL
46	16694600/1	1	CORONA	RING GEAR	COURONNE	KRANZ
47	12360354/1	4	DADO	NUT	ECROU	MUTTER
48	25160010/0	2	DISTANZIALE	SPACER	ENTRETOISE	ENTFERNUNGSSTÜCK
49	22207319/0	6	FLANGIA	FLANGE	BRIDE	FLANSCH
50	25122201/0	3	CUSCINETTO	BEARING	COUSSINET	KUGELLAGER
51	12293201/0	4	DADO	NUT	ECROU	MUTTER
52	12793301/0	2	VITE	SCREW	VIS	SCHRAUBE
54	82680003/0	2	RUOTA COMPLETA (TURF-SAVER)	WHEEL ASS.Y (TURF-SAVER)	ENSEMBLE ROUE (TURF-SAVER)	RAD (TURF-SAVER)
55	82000592/0	2	CERCHIO RUOTA POST.	REAR RIMM	BANDAGE ROUE POST.	HINTERRAD FELGER
56	25590001/0	2	PNEUMATICO (TURF-SAVER)	SHOE (TURF-SAVER)	PNEU (TURF-SAVER)	REIFEN (TURF-SAVER)
57	25670005/1	2	RONDELLA	WASHER	RONDELLE	SCHEIBE
58	12001010/0	2	ANELLO ELASTICO	SNAP RING	ANNEAU RESSORT	SPRENGRING
59	82110251/1	2	COPRIRUOTA POST. (TC)	REAR WHEEL DECK (TC)	COUVRE ROUE POST. (TC)	HINTERRADDECKEL (TC)
	82110253/0	2	COPRIRUOTA POST. (TCP)	REAR WHEEL DECK (TCP)	COUVRE ROUE POST. (TCP)	HINTERRADDECKEL (TCP)
60	25430209/0	8	MOLLA AGGANCIO	SPRING	RESSORT	FEDER
61	22110230/0	2	COPRIMOZZO	HUB COVER	COUVRE MOYEU	RADNABE DECKEL
62	25950000/0	2	VALVOLA	VALVE	SOUPAPE	VENTIL

PER LA SOSTITUZIONE DELLE PARTI CONTRASSEGNALE CON «\*» RIVOLGERSI AL SERVIZIO ASSISTENZA DEL COSTRUTTORE (TECUMSEH).

TO REPLACE THE PARTS MARKED «\*» SEEK ASSISTANCE FROM MANUFACTURER'S AFTER SALES SERVICE (TECUMSEH).

POUR LE REMPLACEMENT DES PIÈCES MARQUÉES AVEC «\*» S'ADRESSER AU SERVICE APRÈS VENTES DU CONSTRUCTEUR (TECUMSEH).

ZUM AUSTAUSCH DER MIT «\*» GEKENNZEICHNETEN TEILE, WENDEN SIE SICH AN DEN KUNDENDIENST DES HERSTELLERS (TECUMSEH).

www.emc-motocycle.com

TC102

TC102 hy. TC122 hy.

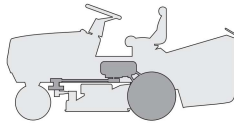
**TRASMISSIONE**  
**TRANSMISSION**  
**TRANSMISSION**  
**GETRIEBE**

1999

006Y.0

1 / 2

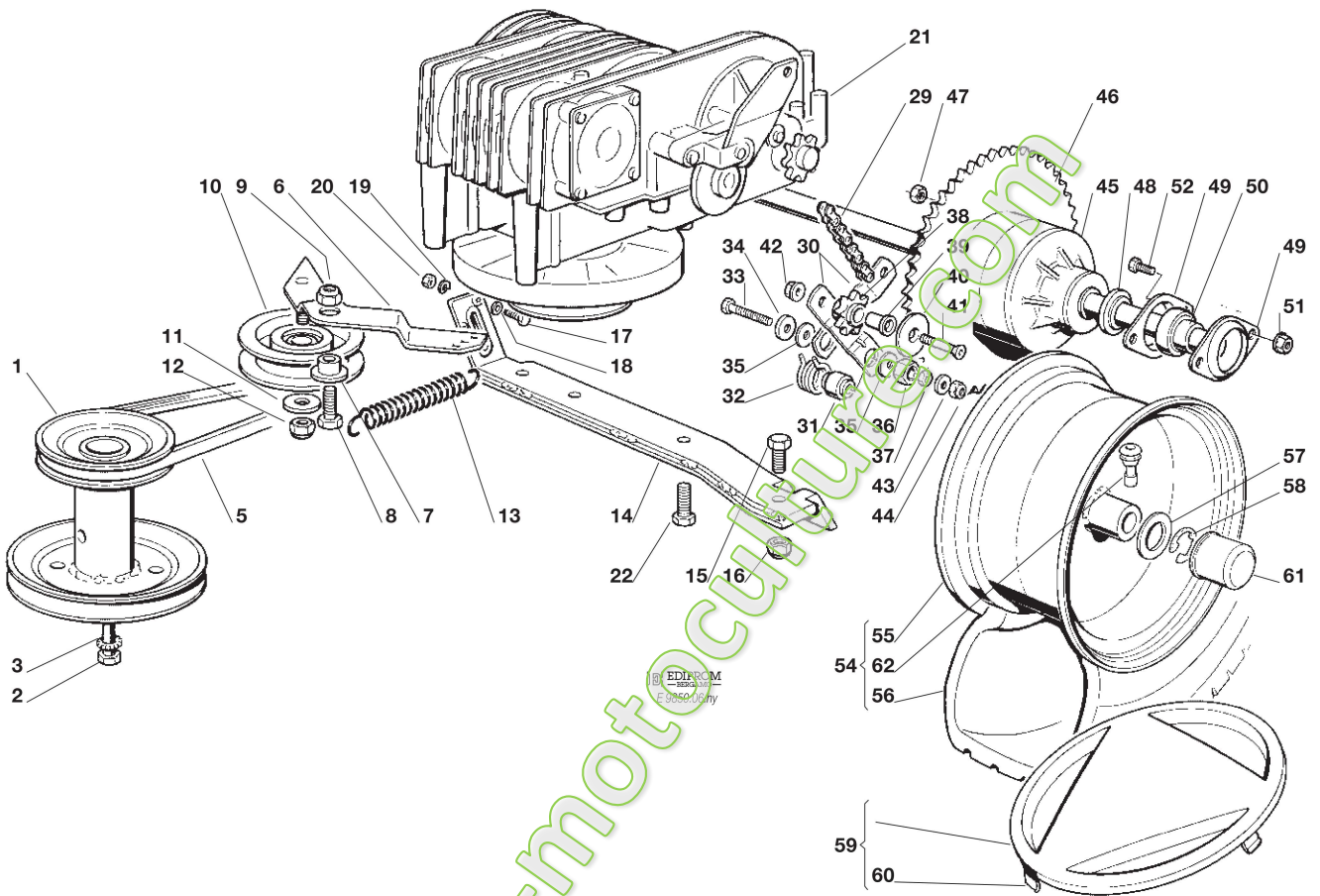

N.	CODE	Q.TY	DESCRIZIONE	DESCRIPTION	DESCRIPTION	BESCHREIBUNG
1	25601565/1	1	PULEGGIA MOTORE	ENGINE PULLEY	POULIE MOTEUR	RIEMENSCHLEIBE
2	12737310/0	1	VITE	SCREW	VIS	SCHRAUBE
3	12543000/0	1	RONDELLA	WASHER	RONDELLE	SCHLEIBE
5	35061426/0	1	CINGHIA	BELT	COURROIE	RIEMEN
6	82318113/0	1	LEVA GALOPPINGO	TIGHTENER LEVER	LEVIER GALOPIN	LEIT ROLLE
7	25038002/0	1	BOCCOLA	BUSHING	DOUILLE	BÜCHSE
8	12793102/0	1	VITE	SCREW	VIS	SCHRAUBE
9	12155000/0	1	DADO	NUT	ECROU	MUTTER
10	25601554/0	1	PULEGGIA	PULLEY	POULIE	RIEMENSCHLEIBE
11	12523060/0	1	RONDELLA	WASHER	RONDELLE	SCHLEIBE
12	12155000/0	1	DADO	NUT	ECROU	MUTTER
13	25430219/0	1	MOLLA	SPRING	RESSORT	FEDER
14	82785095/0	1	SUPPORTO	BRACKET	SUPPORT	SUPPORT
15	12793301/0	2	VITE	SCREW	VIS	SCHRAUBE
16	12155010/0	2	DADO	NUT	ECROU	MUTTER
17	12651010/0	2	VITE	SCREW	VIS	SCHRAUBE
18	12521300/0	2	RONDELLA	WASHER	RONDELLE	SCHLEIBE
19	12581100/0	2	GROWER	GROWER	GROWER	GROWER
20	12290791/0	2	DADO	NUT	ECROU	MUTTER
21★	18400900/0	1	GRUPPO IDROSTATICO	HYDROSTATIC UNIT	ENS. HYDROSTATIQUE	HYDROSTATIK GRUPPE
22	12735595/0	4	VITE	SCREW	VIS	SCHRAUBE
29	15189001/0	1	CATENA	CHAIN	CHAINE	KETTE
30	25318122/0	2	LEVA FLOTTANTE	FLOATING LEVER	LEVIER	HEBEL
31	25040607/0	1	BUSSOLA	BUSH	DOUILLE	BÜCHSE
32	25430207/0	1	MOLLA	SPRING	RESSORT	FEDER
33	25943002/0	1	VITE	SCREW	VIS	SCHRAUBE
34	12523070/0	1	ROSETTA	WASHER	RONDELLE	SCHLEIBE
35	22672152/0	2	RONDELLA ANTIFRIZIONE	WASHER	RONDELLE	SCHLEIBE
36	25160006/0	1	DISTANZIALE	SPACER	ENTRETOISE	ENTFERNUNGSSTÜCK
37	12293200/0	1	DADO	NUT	ECROU	MUTTER
38	25570001/0	2	PIGNONE	PINION	PIGNON	RITZEL



N.	CODE	Q.TY	DESCRIZIONE	DESCRIPTION	DESCRIPTION	BESCHREIBUNG
39	25040608/0	2	BUSSOLA	BUSH	DOUILLE	BUCHSE
40	25670009/0	2	RONDELLA	WASHER	RONDELLE	SCHEIBE
41	12882020/0	2	VITE	SCREW	VIS	SCHRAUBE
42	12155000/0	2	DADO	NUT	ECROU	MUTTER
43	12524010/0	1	ROSETTA	WASHER	RONDELLE	SCHEIBE
44	12155000/0	1	DADO	NUT	ECROU	MUTTER
45★	25140201/0	1	DIFFERENZIALE	DIFFERENTIAL GEAR	DIFFERENTIEL	DIFFERENTIAL
46	16694600/1	1	CORONA	RING GEAR	COURONNE	KRANZ
47	12360354/1	4	DADO	NUT	ECROU	MUTTER
48	25160010/0	2	DISTANZIALE	SPACER	ENTRETOISE	ENTFERNUNGSSTÜCK
49	22207319/0	6	FLANGIA	FLANGE	BRIDE	FLANSCH
50	25122201/0	3	CUSCINETTO	BEARING	COUSSINET	KUGELLAGER
51	12293201/0	4	DADO	NUT	ECROU	MUTTER
52	12793301/0	2	VITE	SCREW	VIS	SCHRAUBE
54	82680003/0	2	RUOTA COMPLETA (TURF-SAVER)	WHEEL ASS.Y (TURF-SAVER)	ENSEMBLE ROUE (TURF-SAVER)	RAD (TURF-SAVER)
55	82000592/0	2	CERCHIO RUOTA POST.	REAR RIMM	BANDAGE ROUE POST.	HINTERRAD FELGER
56	25590001/0	2	PNEUMATICO (TURF-SAVER)	SHOE (TURF-SAVER)	PNEU (TURF-SAVER)	REIFEN (TURF-SAVER)
57	25670005/1	2	RONDELLA	WASHER	RONDELLE	SCHEIBE
58	12001010/0	2	ANELLO ELASTICO	SNAP RING	ANNEAU RESSORT	SPRENGRING
59	82110251/1	2	COPRIRUOTA POST. (TC)	REAR WHEEL DECK (TC)	COUVRE ROUE POST. (TC)	HINTERRADDECKEL (TC)
	82110253/0	2	COPRIRUOTA POST. (TCP)	REAR WHEEL DECK (TCP)	COUVRE ROUE POST. (TCP)	HINTERRADDECKEL (TCP)
60	25430209/0	8	MOLLA AGGANCIAMENTO	SPRING	RESSORT	FEDER
61	22110230/0	2	COPRIMOZZO	HUB COVER	COUVRE MOYEU	RADNABE DECKEL
62	25950000/0	2	VALVOLA	VALVE	SOUPAPE	VENTIL

PER LA SOSTITUZIONE DELLE PARTI CONTRASSEGNALE CON «★» RIVOLGERSI AL SERVIZIO ASSISTENZA DEL COSTRUTTORE (TECUMSEH).  
 TO REPLACE THE PARTS MARKED «★» SEEK ASSISTANCE FROM MANUFACTURER'S AFTER SALES SERVICE (TECUMSEH).  
 POUR LE REMPLACEMENT DES PIÈCES MARQUÉES AVEC «★» S'ADRESSER AU SERVICE APRÈS VENTES DU CONSTRUCTEUR (TECUMSEH).  
 ZUM AUSTAUSCH DER MIT «★» GEKENNZEICHNETEN TEILE, WENDEN SIE SICH AN DEN KUNDENDIENST DES HERSTELLERS (TECUMSEH).

www.emc-motoculture.com

TC102

TC102 hy.

TC122 hy.

TCP102

TCP102 hy.

TCP122 hy.

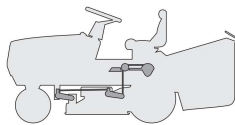

SOLLEVAMENTO PIATTO DI TAGLIO  
CUTTING PLATE LIFTING  
SOULEVEMENT PLATEAU DE COUPE  
SCHNEIDWERKZEUG AUFHEBESATZ

1999

007.0

1 / 2

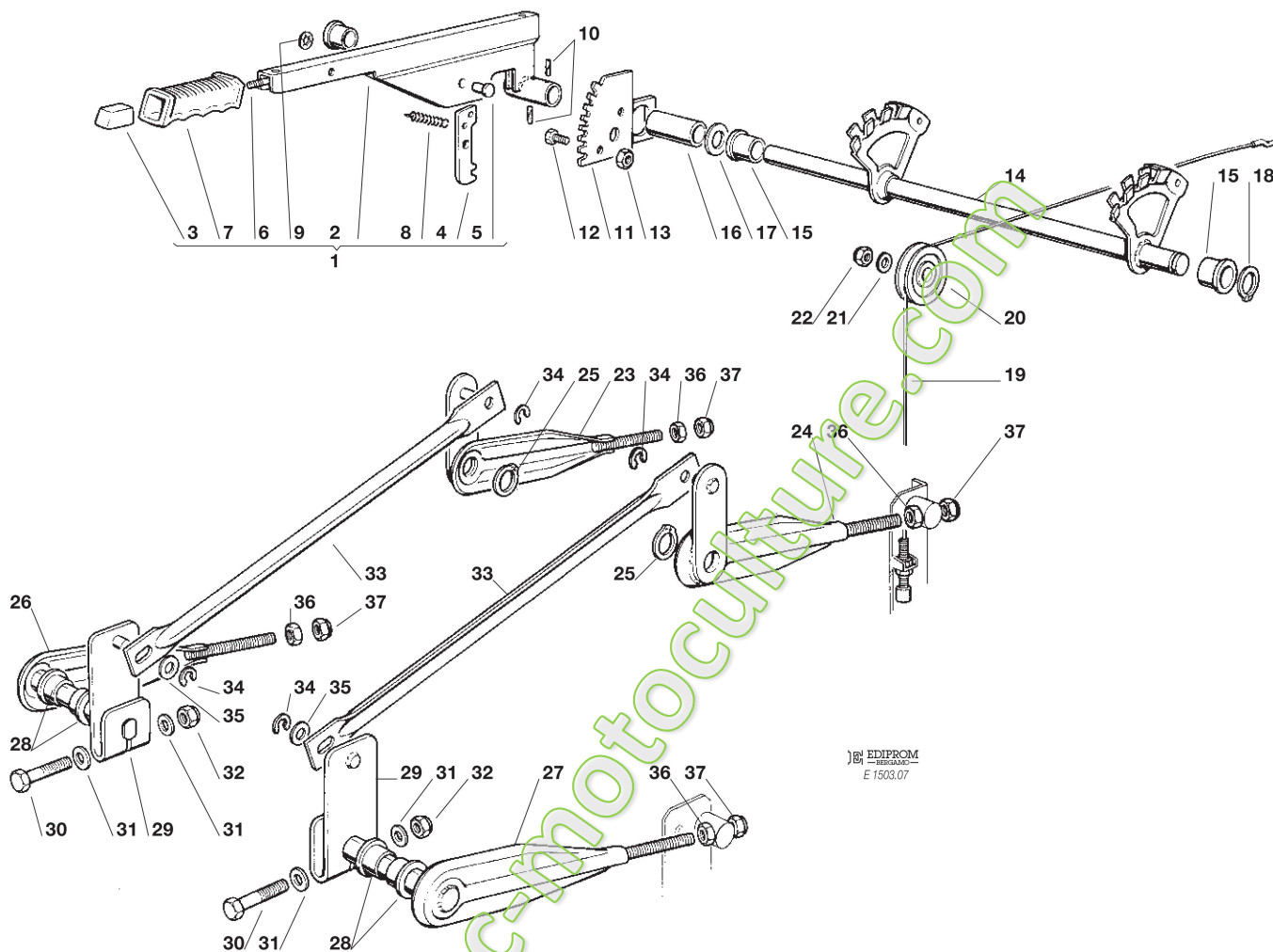

EDIPROM  
E 1503.07

N.	CODE	Q.TY	DESCRIZIONE	DESCRIPTION	DESCRIPTION	BESCHREIBUNG
1	82300000/0	1	ASS. GRUPPO LEVA SOLLEVAMENTO PIATTO	LIFTING LEVER ASS.Y	ENS. LEVIER SOULEVEMENT PLATEAU DE COUPE	SCHNEIDWERKZEUG AUFHEBENHEBEL
2	82318103/0	1	LEVA SOLLEVAMENTO	LIFTING LEVER	LEVIER DE SOULEVEMENT	AUFHEBENHEBEL
3	25605000/1	1	PULSANTE	BUTTON	POUSSOIR	DRUCKKNOPF
4	25470901/0	1	NASELLO	DOG	DECLIC	NASE
5	25510011/0	1	PERNO	PIN	PIVOT	BOLZEN
6	25033002/0	1	ASTA COMANDO	PUSHROD	TIGE COMMANDE	BETAETIGUNGSSTAB
7	25394504/0	1	MANOPOCA	KNOB	POIGNEE	GRIFF
8	25430208/0	1	MOLLA	SPRING	RESSORT	FEDER
9	12604899/0	1	RONDELLA	WASHER	RONDELLE	SCHEIBE
10	12620206/0	1	SPINA	PIN	GOUPILLE	STIFT
11	25735501/0	1	SETTORE REGOLAZIONE	ADJ. SECTOR	SECTEUR REGLEMENT	EINSTELLESEKTOR
12	12792611/0	2	VITE	SCREW	VIS	SCHRAUBE
13	12293201/0	2	DADO	NUT	ECROU	MUTTER
14	82000401/1	1	ASS. ASSE SOLLEVAMENTO	LIFTING SHAFT	ARBRE SOULEVEMENT	AUFHEBENACHSE
15	22034523/0	3	BOCCOLA	BUSH	DOUILLE	BÜCHSE
16	25160004/0	1	DISTANZIALE	SPACER	ENTRETOISE	ENTFERNUNGSSTUECK
17	12521410/0	1	RONDELLA	WASHER	RONDELLE	SCHEIBE
18	12609260/0	1	SEEGER	SEEGER	SEEGER	SEEGER
19	82004600/0	2	ASS. FILO SOLLEVAMENTO	LIFTING WIRE	ENS. FIL SOULEVEMENT	AUFHEBENKABEL
	82004605/0	1	FILO SOLLEVAMENTO SINISTRO (hydro)	LIFTING WIRE - LEFT (hydro)	ENS. FIL SOULEVEMENT GAUCHE (hydro)	AUFHEBENKABEL LINKE (hydro)
20	25601557/0	2	PULEGGIA	PULLEY	POULIE	SCHEIBE
21	12521350/0	2	RONDELLA	WASHER	RONDELLE	SCHEIBE
22	12155000/0	2	DADO	NUT	ECROU	MUTTER
23	82318105/1	1	LEVA FULCRO DX (TC(P) 102)	RIGHT FULCRUM LEVER (TC(P) 102)	LEVIER POINT D'APPUI DROITE (TC(P) 102)	RECHTER SCHWENKPUNKT HEBEL (TC(P) 102)
	82318119/1	1	LEVA FULCRO DX (TC(P) 122)	RIGHT FULCRUM LEVER (TC(P) 122)	LEVIER POINT D'APPUI DROITE (TC(P) 122)	RECHTER SCHWENKPUNKT HEBEL (TC(P) 122)
24	82318107/1	1	LEVA FULCRO SX (TC(P) 102)	LEFT FULCRUM LEVER (TC(P) 102)	LEVIER POINT D'APPUI GAUCHE (TC(P) 102)	LINKER SCHWENKPUNKT HEBEL (TC(P) 102)



N.	CODE	Q.TY	DESCRIZIONE	DESCRIPTION	DESCRIPTION	BESCHREIBUNG
	82318121/1	1	LEVA FULCRO SX <b>(TC(P) 122)</b>	LEFT FULCRUM LEVER <b>(TC(P) 122)</b>	LEVIER POINT D'APPUI GAUCHE <b>(TC(P) 122)</b>	LINKER SCHWENKPUNKT HEBEL <b>(TC(P) 122)</b>
25	12609255/0	2	ANELLO	RING	ANNEAU	RING
26	82318115/0	1	LEVA FULCRO ANTERIORE DX <b>(TC(P) 102)</b>	FRONT FULCRUM LEVER RIGHT <b>(TC(P) 102)</b>	LEVIER POINT D'APPUI ANT. DROITE <b>(TC(P) 102)</b>	RECHTER VORDERSCHWENK- PUNKTHEBEL <b>(TC(P) 102)</b>
	82318123/0	1	LEVA FULCRO ANTERIORE DX <b>(TC(P) 122)</b>	FRONT FULCRUM LEVER RIGHT <b>(TC(P) 122)</b>	LEVIER POINT D'APPUI ANT. DROITE <b>(TC(P) 122)</b>	RECHTER VORDERSCHWENK- PUNKTHEBEL <b>(TC(P) 122)</b>
27	82318117/0	1	LEVA FULCRO ANTERIORE SX <b>(TC(P) 102)</b>	FRONT FULCRUM LEVER LEFT <b>(TC(P) 102)</b>	LEVIER POINT D'APPUI ANT. GAUCHE <b>(TC(P) 102)</b>	LINKER VORDERSCHWENK- PUNKTHEBEL <b>(TC(P) 102)</b>
	82318125/0	1	LEVA FULCRO ANTERIORE SX <b>(TC(P) 122)</b>	FRONT FULCRUM LEVER LEFT <b>(TC(P) 122)</b>	LEVIER POINT D'APPUI ANT. GAUCHE <b>(TC(P) 122)</b>	LINKER VORDERSCHWENK- PUNKTHEBEL <b>(TC(P) 122)</b>
28	25040605/0	4	BUSSOLA	BUSH	DOUILLE	BÜCHSE
29	82318109/0	2	LEVA ASTA COLLEGAMENTO	CONNECTING ROD LEVER	LEVIER TIGE DE CONNEXION	VERBINDUNGSSTAB HEBEL
30	12691700/0	2	VITE	SCREW	VIS	SCHRAUBE
31	12521350/0	4	RONDELLA	WASHER	RONDELLE	SCHEIBE
32	12155000/0	2	DADO	NUT	ECROU	MUTTER
33	25033001/0	2	ASTA COLLEGAMENTO	CONNECTING ROD	TIGE DE CONNEXION	VERBINDUNGSSTAB
34	12000955/0	4	ANELLO ELASTICO	SNAP RING	ANNEAU RESSORT	SPRENGRING
35	25670008/0	2	RONDELLA	WASHER	RONDELLE	SCHEIBE
36	12295200/0	4	DADO	NUT	ECROU	MUTTER
37	12156602/0	4	DADO	NUT	ECROU	MUTTER

www.emc-motoculture.com

TC102

TC102 hy.

TC122 hy.

TCP102

TCP102 hy.

TCP122 hy.

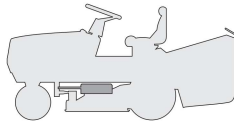

PIATTO DI TAGLIO (1)

CUTTING PLATE (1)

PLATEAU DE COUPE (1)

SCHNEIDWERKZEUG (1)

1999

008.0

1 / 2

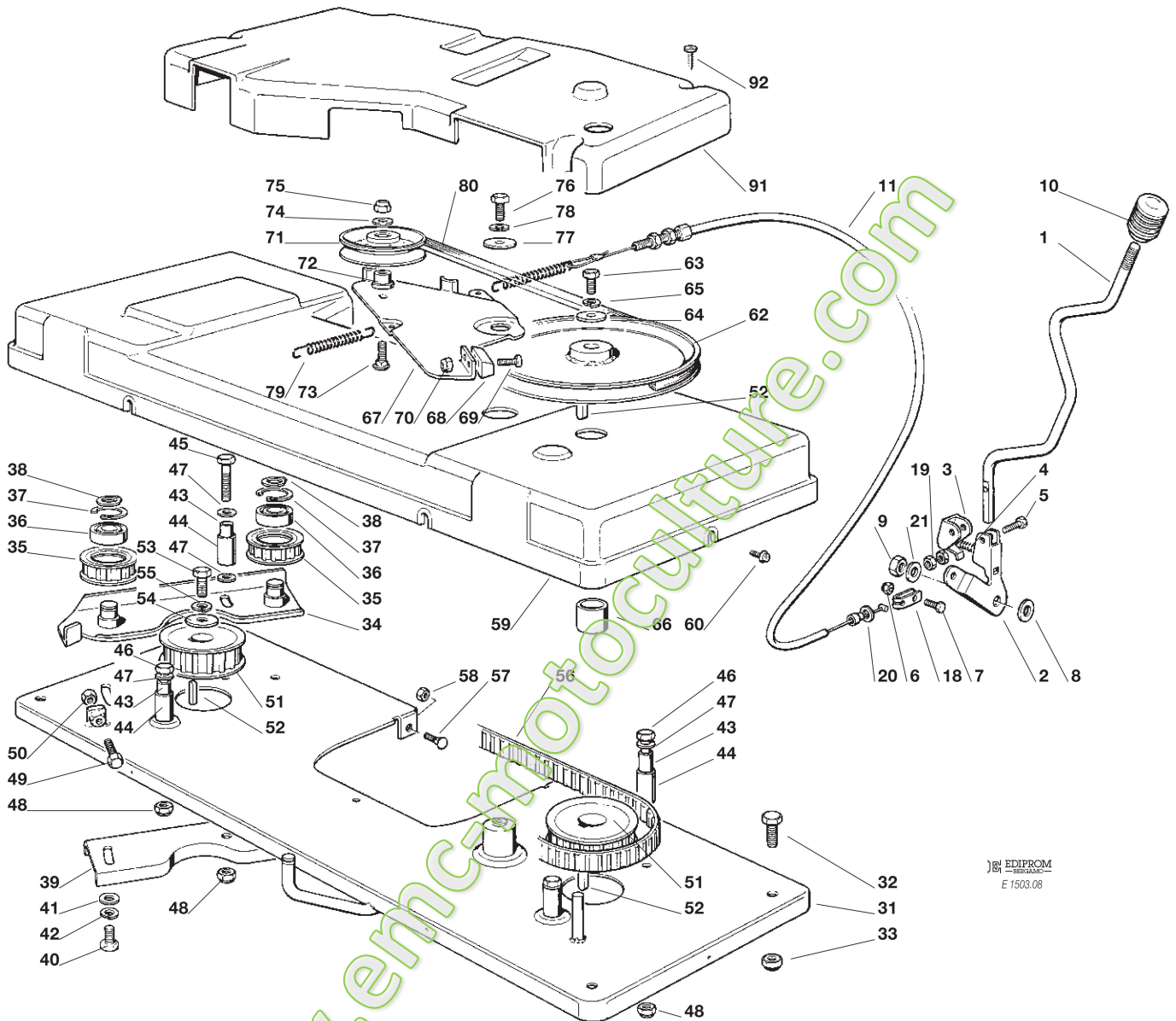

EDIPROM  
E 1503.08

N.	CODE	Q.TY	DESCRIZIONE	DESCRIPTION	DESCRIPTION	BESCHREIBUNG
1	25318120/0	1	LEVA INNESTO	ENGAGING LEVER	LEVIER D'EMBRAYAGE	EINSCHALTENHEBEL
2	82774209/0	1	STAFFA LEVA	CLAMP LEVER	BRIDE POUR LEVIER	BRIDE FÜR HEBEL
3	25774211/1	1	STAFFA MOLLA	CLAMP SPRING	BRIDE POUR RESSORT	BRIDE FÜR FEDER
4	25430206/1	1	MOLLA	SPRING	RESSORT	FEDER
5	12674550/0	1	VITE	SCREW	VIS	SCHRAUBE
6	12154510/0	1	DADO	NUT	ECROU	MUTTER
7	12791213/0	1	VITE	SCREW	VIS	SCHRAUBE
8	22672151/0	1	RONDELLA	WASHER	RONDELLE	SCHEIBE
9	12155010/0	1	DADO	NUT	ECROU	MUTTER
10	25394503/1	1	MANOPOLA	HANDLE	POIGNÉE	GRIF
11	82004601/2	1	ASSIEME FILO (TC(P) 102)	WIRE ASS.Y (TC(P) 102)	ENSEMBLE FIL (TC(P) 102)	KABEL (TC(P) 102)
	82004602/3	1	ASSIEME FILO (TC(P) 122)	WIRE ASS.Y (TC(P) 122)	ENSEMBLE FIL (TC(P) 122)	KABEL (TC(P) 122)
18	22061337/0	1	CAVALLOTTO	CONNECTING PLATE	PLAQUE DE CONNEXION	BUGEL BOLZEN
19	12292100/0	2	DADO	NUT	ECROU	MUTTER
20	12521350/0	1	RONDELLA	WASHER	RONDELLE	SCHEIBE
21	12523060/0	1	RONDELLA	WASHER	RONDELLE	SCHEIBE
31	82547003/1	1	PIASTRA (TC(P) 102)	PLATE (TC(P) 102)	PLATE (TC(P) 102)	PLATTE (TC(P) 102)
	82547005/0	1	PIASTRA (TC(P) 122)	PLATE (TC(P) 122)	PLATE (TC(P) 122)	PLATTE (TC(P) 122)
32	12792611/0	4	VITE	SCREW	VIS	SCHRAUBE
33	12293201/0	4	DADO	NUT	ECROU	MUTTER
34	82785084/1	1	SUPPORTO	SUPPORT	SUPPORT	HALTERSATZ
35	25601559/1	2	PULLEGIA (TC(P) 102)	PULLEY (TC(P) 102)	POULIE (TC(P) 102)	RIEMENSCHLEIBE (TC(P) 102)
	25601561/0	2	PULLEGIA (TC(P) 122)	PULLEY (TC(P) 122)	POULIE (TC(P) 122)	RIEMENSCHLEIBE (TC(P) 122)



N.	CODE	Q.TY	DESCRIZIONE	DESCRIPTION	DESCRIPTION	BESCHREIBUNG
36	19216033/1	2	CUSCINETTO	BEARING	ROULEMENT	KUEGELLAGER
37	12610800/0	2	SEEGER	SEEGER	SEEGER	SEEGER
38	12609200/0	2	SEEGER	SEEGER	SEEGER	SEEGER
39	25650037/0	1	RINF. PULEGGE	PULLEY STIFFENING	REINFORCEMENT DES POULIE	RIEMENSCHLEIBE VERSTAERKUNG
40	12793102/0	2	VITE	SCREW	VIS	SCHRAUBE
41	12521350/0	2	RONDELLA	WASHER	RONDELLE	SCHLEIBE
42	12583500/0	2	GROWER	GROWER	GROWER	GROWER
43	25160003/0	4	DISTANZIALE	SPACER	ENTRETOISE	DISTANZRING
44	25038000/0	4	BOCCOLA	BUSHING	DOUILLE	BUEHSE
45	12691700/0	1	VITE	SCREW	VIS	SCHRAUBE
46	12691200/0	3	VITE	SCREW	VIS	SCHRAUBE
47	12521350/0	5	RONDELLA	WASHER	RONDELLE	SCHLEIBE
48	12155000/0	4	DADO	NUT	ECROU	MUTTER
49	12793900/0	1	VITE	SCREW	VIS	SCHRAUBE
50	12293200/0	1	DADO	NUT	ECROU	MUTTER
51	25601560/0	2	PULEGGIA (TC(P) 102)	PULLEY (TC(P) 102)	POULIE (TC(P) 102)	RIEMENSCHLEIBE (TC(P) 102)
	25601562/0	2	PULEGGIA (TC(P) 122)	PULLEY (TC(P) 122)	POULIE (TC(P) 122)	RIEMENSCHLEIBE (TC(P) 122)
52	12139480/0	3	CHIAVETTA	KEY	CLAVETTE	KEIL
53	12793102/0	1	VITE	SCREW	VIS	SCHRAUBE
54	25670007/0	1	RONDELLA	WASHER	RONDELLE	SCHLEIBE
55	12583500/0	1	GROWER	GROWER	GROWER	GROWER
56	35065600/0	1	CINGHIA (TC(P) 102)	BELT (TC(P) 102)	COURROIE (TC(P) 102)	KEILRIEMEN (TC(P) 102)
	35065601/0	1	CINGHIA (TC(P) 122)	BELT (TC(P) 122)	COURROIE (TC(P) 122)	KEILRIEMEN (TC(P) 122)
57	12815200/0	3	VITE	SCREW	VIS	SCHRAUBE
58	12292102/0	3	DADO	NUT	ECROU	MUTTER
59	25060100/1	1	CARTER (TC(P) 102)	CASE (TC(P) 102)	CARTER (TC(P) 102)	BLECH (TC(P) 102)
	25060101/0	1	CARTER (TC(P) 122)	CASE (TC(P) 122)	CARTER (TC(P) 122)	BLECH (TC(P) 122)
60	12735110/0	6	VITE	SCREW	VIS	SCHRAUBE
62	25601550/0	1	PULEGGIA (TC(P) 102)	PULLEY (TC(P) 102)	POULIE (TC(P) 102)	RIEMENSCHLEIBE (TC(P) 102)
	25601549/0	1	PULEGGIA (TC(P) 122)	PULLEY (TC(P) 122)	POULIE (TC(P) 122)	RIEMENSCHLEIBE (TC(P) 122)
63	12793102/0	1	VITE	SCREW	VIS	SCHRAUBE
64	25670007/0	1	RONDELLA	WASHER	RONDELLE	SCHLEIBE
65	12583500/0	1	GROWER	GROWER	GROWER	GROWER
66	25160002/0	1	DISTANZIALE	SPACER	ENTRETOISE	DISTANZRING
67	25318115/0	1	LEVA FRENO (TC(P) 102)	BRAKE LEVER (TC(P) 102)	LEVIER FREIN (TC(P) 102)	BREMSHEBEL (TC(P) 102)
	25318119/0	1	LEVA FRENO (TC(P) 122)	BRAKE LEVER (TC(P) 122)	LEVIER FREIN (TC(P) 122)	BREMSHEBEL (TC(P) 122)
68	25207000/1	1	FERODO	LINING	PASTILLE FREIN	BREMSBELAG
69	12771400/0	2	VITE	SCREW	VIS	SCHRAUBE
70	12154330/0	2	DADO	NUT	ECROU	MUTTER
71	25601555/0	1	PULEGGIA	PULLEY	POULIE	RIEMENSCHLEIBE
72	25160007/0	1	DISTANZIALE	SPACER	ENTRETOISE	DISTANZRING
73	12818900/0	1	VITE	SCREW	VIS	SCHRAUBE
74	12523060/0	1	RONDELLA	WASHER	RONDELLE	SCHLEIBE
75	12155000/0	1	DADO	NUT	ECROU	MUTTER
76	12793102/0	1	VITE	SCREW	VIS	SCHRAUBE
77	12523070/0	1	RONDELLA	WASHER	RONDELLE	SCHLEIBE
78	12583500/0	1	GROWER	GROWER	GROWER	GROWER
79	25430210/0	1	MOLLA FRENO LAMA (TC(P) 102)	BLADE BRAKE SPRING (TC(P) 102)	RESSORT FREIN LAME (TC(P) 102)	MESSER BREMSE FEDER (TC(P) 102)
	25430220/0	1	MOLLA FRENO LAMA (TC(P) 122)	BLADE BRAKE SPRING (TC(P) 122)	RESSORT FREIN LAME (TC(P) 122)	MESSER BREMSE FEDER (TC(P) 122)
80	35062813/0	1	CINGHIA (TC(P) 102)	BELT (TC(P) 102)	COURROIE (TC(P) 102)	KEIL RIEMEN (TC(P) 102)
	35062814/0	1	CINGHIA (TC(P) 122)	BELT (TC(P) 122)	COURROIE (TC(P) 122)	KEIL RIEMEN (TC(P) 122)
91	25600000/0	1	PROTEZIONE CINGHIA POST. (TC(P) 102)	REAR BELT PROTECTION (TC(P) 102)	PROTECTION COURROIRE POSTERIEURE (TC(P) 102)	HINTERR RIEMENSCHUTZ (TC(P) 102)
	25600008/0	1	PROTEZIONE CINGHIA POST. (TC(P) 122)	REAR BELT PROTECTION (TC(P) 122)	PROTECTION COURROIRE POSTERIEURE (TC(P) 122)	HINTERR RIEMENSCHUTZ (TC(P) 122)
92	12735402/0	4	VITE	SCREW	VIS	SCHRAUBE

TC102

TC102 hy. TC122 hy.

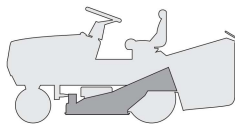

PIATTO DI TAGLIO (2)

CUTTING PLATE (2)

PLATEAU DE COUPE (2)

SCHNEIDWERKZEUG (2)

1999

009.0

1 / 2

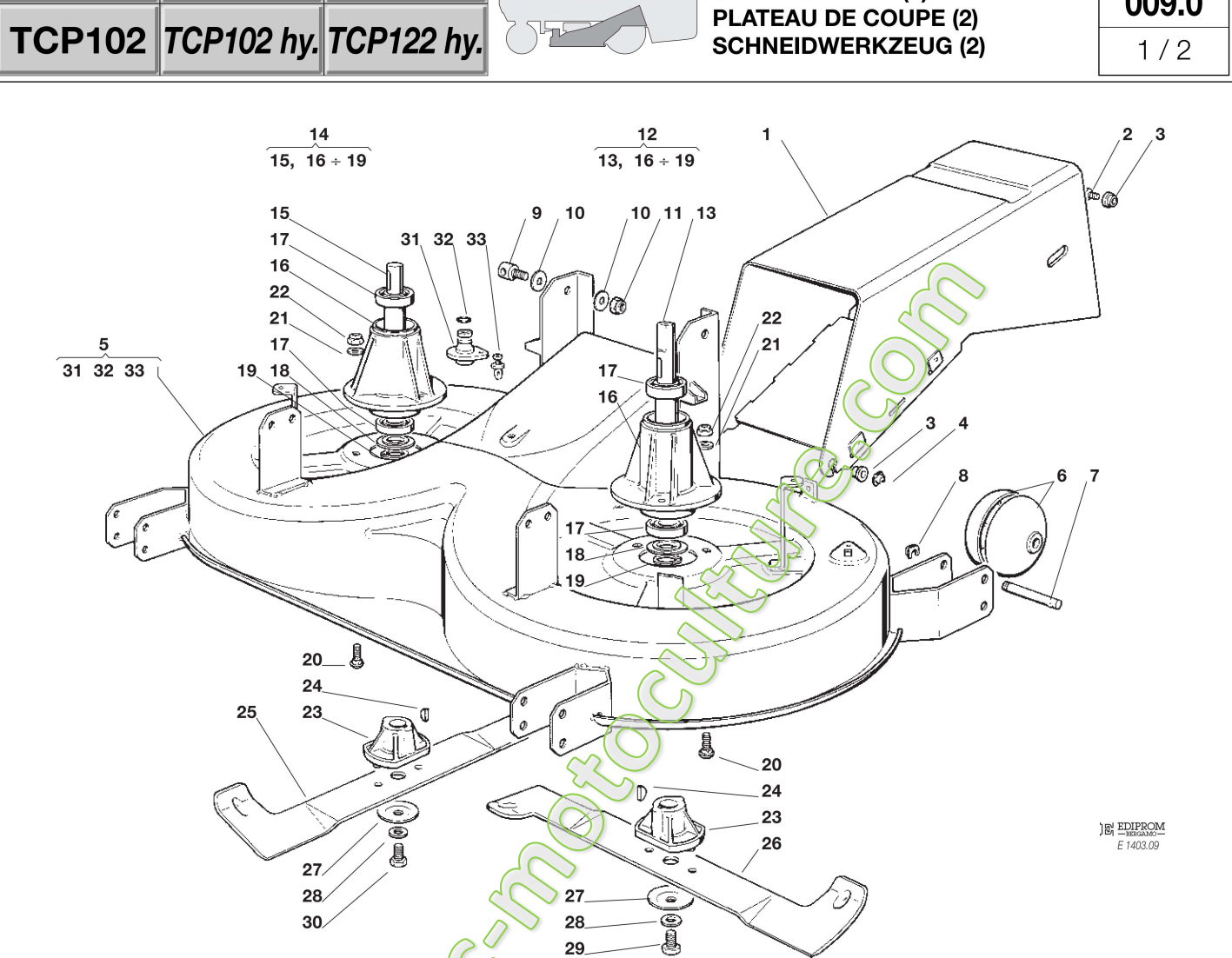
 EDIPROM  
 E 1403.09

N.	CODE	Q.TY	DESCRIZIONE	DESCRIPTION	DESCRIPTION	BESCHREIBUNG
1	82108004/0	1	CONVOGLIATORE POSTER.	REAR CONVEYOR ASS.Y	ENS. CONVOYEUR POST.	HINTERLEITBLECHSATZ
2	12793102/0	2	VITE	SCREW	VIS	SCHRAUBE
3	25038002/0	4	BOCCOLA	BUSHING	DOUILLE	BUCHSE
4	12436050/0	2	PIASTRINA	PLATE	PLAQUE	PLATTE
5	82565005/0	1	ASSIEME PIATTO DI TAGLIO (+32-33-34) <b>(TC(P) 102)</b>	CUTTING PLATE ASS.Y (+32-33-34) <b>(TC(P) 102)</b>	ENS. PLATEAU DE COUPE (+32-33-34) <b>(TC(P) 102)</b>	SCHNEIDWERKZEUG (+32-33-34) <b>(TC(P) 102)</b>
	82565008/0	1	ASSIEME PIATTO DI TAGLIO (+32-33-34) <b>(TC(P) 122)</b>	CUTTING PLATE ASS.Y (+32-33-34) <b>(TC(P) 122)</b>	ENS. PLATEAU DE COUPE (+32-33-34) <b>(TC(P) 122)</b>	SCHNEIDWERKZEUG (+32-33-34) <b>(TC(P) 122)</b>
6	82700000/0	4	RUOTINO ANTISCALPO	LEVELLING SMALL WHEEL	ROULETTES ANTISCALP	EBENUNGRAEDCHEN
7	25510006/0	4	PERNO	PIN	PIVOT	BOLZEN
8	12436030/0	4	PIASTRINA	PLATE	PLAQUE	PLATTE
9	25510024/0	4	PERNO	PIN	PIVOT	BOLZEN
10	25670008/0	8	RONDELLA	WASHER	RONDELLE	SCHEIBE
11	12156602/0	4	DADO	NUT	ECROU	MUTTER
12	82207200/1	1	ASS. FLANGIA ALBERO PRINCIPALE (13, 16÷19)	BLADE MAIN SHAFT SUPPORT (13, 16÷19)	SUPPORT ARBRE LAME PRINCIPAL (13, 16÷19)	MASSERWELLEHAPT- SATZ (13, 16÷19)
13	25020800/1	1	ALBERO LAMA PRINCIPALE	MAIN BLADE SHAFT	ARBRE LAME PRINCIPAL	HAUP MESSERWELLE
14	82207201/2	1	ASS. FLANGIA ALBERO SECONDARIO (15,16÷19)	BLADE SECONDARY SHAFT SUPPORT (15, 16÷19)	SUPPORT ARBRE LAME SECONDAIRE (15,16÷19)	MASSERWELLE ZWEITER- SATZ (15,16÷19)
15	25020801/2	1	ALBERO LAMA SECONDARIO	SECONDARY BLADE SHAFT	ARBRE LAME SECONDAIRE	ZWEITE MESSERWELLE
16	25207200/0	2	FLANGIA ALBERO LAMA	BLADE SHAFT SUPPORT	SUPPORT ARBRE LAME	MESSERWELLE
17	19216032/0	4	CUSCINETTO	BEARING	ROULEMENT	KUEGELLAGER
18	25160501/0	2	DISCO PARAPOLVERE	DUST COVER	PROTEGE-POUSSIÈRE	STAUBSCHUTTSCHIBE
19	12609260/0	2	SEEGER	SEEGER	SEEGER	SEEGER
20	12818700/0	6	VITE	SCREW	VIS	SCHRAUBE
21	12521350/0	6	RONDELLA	WASHER	RONDELLE	SCHEIBE
22	12155000/0	6	DADO	NUT	ECROU	MUTTER
23	25463200/0	2	MOZZO COLTELLO	BLADE HUB	MOYEU LAME	MESSERHALTER
24	12139100/0	2	LINGUETTA	KEY	CLAVETTE	KEIL
25	82004341/0	1	COLTELLO DX <b>(TC(P) 102)</b>	RIGHT BLADE <b>(TC(P) 102)</b>	LAME DROITE <b>(TC(P) 102)</b>	RECHTER MESSER <b>(TC(P) 102)</b>



N.	CODE	Q.TY	DESCRIZIONE	DESCRIPTION	DESCRIPTION	BESCHREIBUNG
	82004343/0	1	COLTELLO DX <b>(TC(P) 122)</b>	RIGHT BLADE <b>(TC(P) 122)</b>	LAME DROITE <b>(TC(P) 122)</b>	RECHTER MESSER <b>(TC(P) 122)</b>
26	82004340/0	1	COLTELLO SX <b>(TC(P) 102)</b>	LEFT BLADE <b>(TC(P) 102)</b>	LAME GAUCHE <b>(TC(P) 102)</b>	LINKER MESSER <b>(TC(P) 102)</b>
	82004342/0	1	COLTELLO SX <b>(TC(P) 122)</b>	LEFT BLADE <b>(TC(P) 122)</b>	LAME GAUCHE <b>(TC(P) 122)</b>	LINKER MESSER <b>(TC(P) 122)</b>
27	22160400/0	2	DISCO ELASTICO	ELASTIC WASHER	RONDELLE ELASTIQUE	FEDERSCHEIBE
28	12523080/0	2	RONDELLA	WASHER	RONDELLE	SCHEIBE
29	12735694/0	1	VITE	SCREW	VIS	SCHRAUBE
30	12735695/1	1	VITE	SCREW	VIS	SCHRAUBE
31	25033060/0	2	ATTACCO TUBO ACQUA	WATER HOSE CONNECTION	RACCORD TUYAU D'EAU	WASSERANSCHLUSS
32	19035000/0	2	ANELLO OR	O RING	O RING	O RING
33	12500030/0	2	RIVETTO	RIVET	RIVET	NIET
—	82565000/1	1	PIATTO DI TAGLIO ASSEMBLATO <b>(TC(P) 102)</b> <b>(008, 31÷92 + 009, 5÷33)</b>	CUTTING PLATE, ASSEMBLED <b>(TC(P) 102)</b> <b>(008, 31÷92 + 009, 5÷33)</b>	PLATEAU DE COUPE,S COMPLETE <b>(TC(P) 102)</b> <b>(008, 31÷92 + 009, 5÷33)</b>	CHNEIDWERKZEUG, KOMPLETT <b>(TC(P) 102)</b> <b>(008, 31÷92 + 009, 5÷33)</b>
—	82565003/1	1	PIATTO DI TAGLIO, ASSEMBLATO <b>(TC(P) 122)</b> <b>(008, 31÷92 + 009, 5÷33)</b>	CUTTING PLATE, ASSEMBLED <b>(TC(P) 122)</b> <b>(008, 31÷92 + 009, 5÷33)</b>	PLATEAU DE COUPE,S COMPLETE <b>(TC(P) 122)</b> <b>(008, 31÷92 + 009, 5÷33)</b>	CHNEIDWERKZEUG, KOMPLETT <b>(TC(P) 122)</b> <b>(008, 31÷92 + 009, 5÷33)</b>

www.emc-motoculture.com

TC102

TC102 hy.

TC122 hy.

TCP102

TCP102 hy.

TCP122 hy.

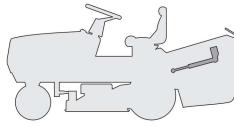

SOLLEVAMENTO SACCO E MICRO SACCO PIENO  
LIFTING DEVICE AND FULL GRASSCAT. MICRO  
SOULEVEMENT BAC ET MICRO BAC PLEIN  
AUSHEBENVORR. UND VOLLKORBEIN RICHTUNG

1999

010.0

1 / 2

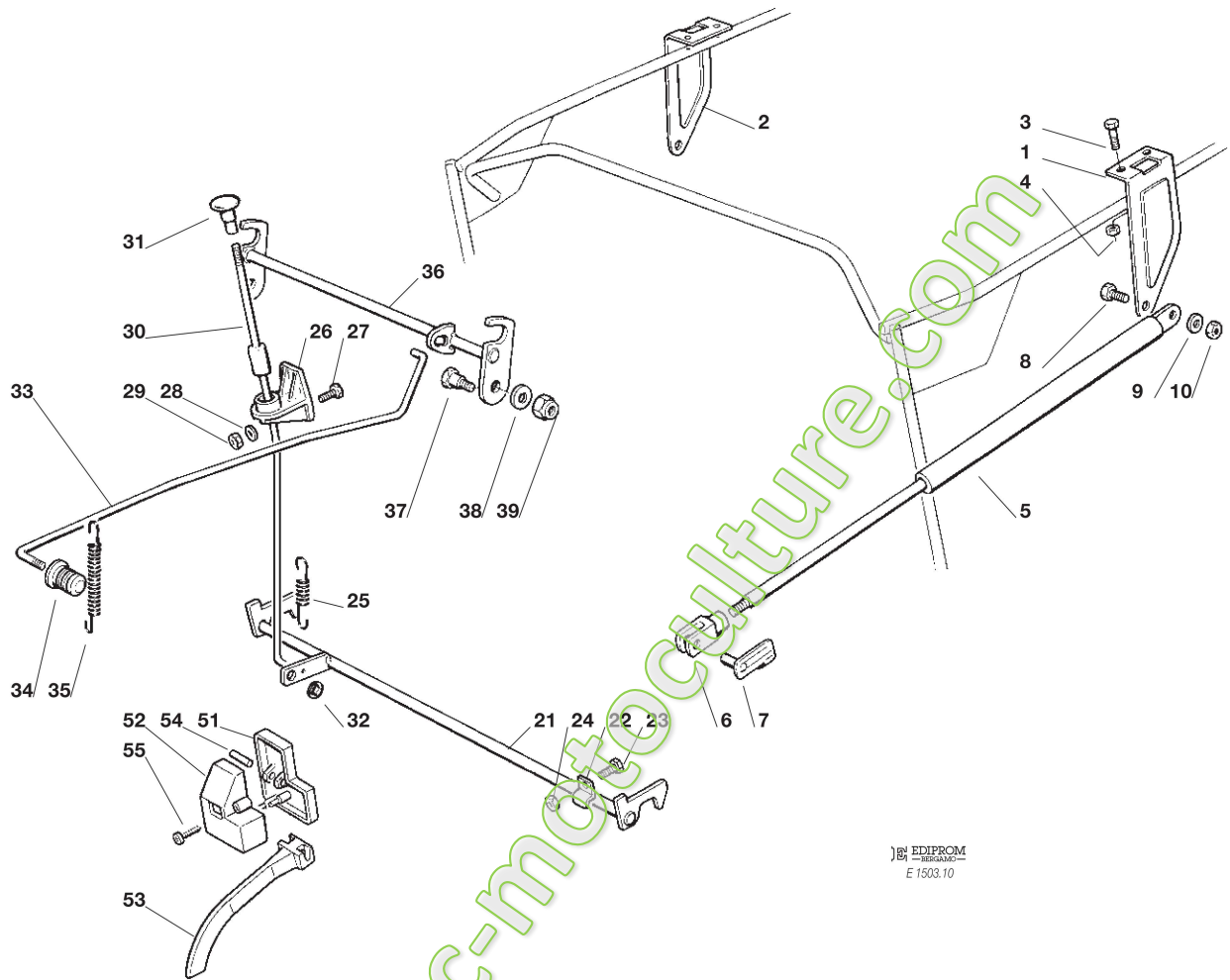

EDIPROM  
E 1503.10

N.	CODE	Q.TY	DESCRIZIONE	DESCRIPTION	DESCRIPTION	BESCHREIBUNG
1	25547005/0	1	PIASTRA SX	LEFT PLATE	PLAQUE GAUCHE	LINKE PLATTE
2	25547007/0	1	PIASTRA DX	RIGHT PLATE	PLAQUE DROITE	RECHTE PLATTE
3	12792611/0	4	VITE	SCREW	VIS	SCHRAUBE
4	12293201/0	4	DADO	NUT	ECROU	MUTTER
5	18564600/0	2	PISTONE SOLLEVAMENTO	LIFTING PISTON	RESSORT A GAZ	GASFEDER
6	18399000/0	2	FORCELLA	FORK	FOURCHE	GABEL
7	18210200/0	2	CLIP	CLIP	CLIP	SPERRBOLZEN
8	12793101/0	2	VITE	SCREW	VIS	SCHRAUBE
9	12521350/0	2	ROSETTA	WASHER	RONDELLE	SCHEIBE
10	12155000/0	2	DADO	NUT	ECROU	MUTTER
21	82000357/0	1	ASTA AGGANCIO SACCO INF.	LOWER COUPLING ROD	TIGE D'ACCROCHAGE INF.	UNTERE KUPPLUNGSTANGE
22	25774220/0	2	STAFFA ANCORAGGIO	ANCHOR BRACKET	ETRIER	BRIDE
23	12791200/0	4	VITE	SCREW	VIS	SCHRAUBE
24	12292102/0	2	DADO	NUT	ECROU	MUTTER
25	25430220/0	1	MOLLA	SPRING	RESSORT	FEDER
26	25785055/0	1	SUPPORTO GUIDA ASTA	SUPPORT	SUPPORT	SUPPORT
27	12791200/0	1	VITE	SCREW	VIS	SCHRAUBE
28	12521330/0	1	ROSETTA	WASHER	RONDELLE	SCHEIBE
29	12154510/0	1	DADO	NUT	ECROU	MUTTER
30	82000462/0	1	ASTA SGANCIO	RELEASE ROD	TIGE DE DECROCHAGE	ENTKUPPLUNGSTANGE
31	82394507/0	1	MANOPOLA	HANDLE	POIGNEE	GRIFF
32	12604898/0	1	RONDELLA DI RITEGNO	WASHER	RONDELLE	SCHEIBE
33	25033015/0	1	ASTA BLOCCAGGIO	LOCKING ROD	TIGE DE BLOCAGE	KLEMENSTANGE
	25033018/0	1	ASTA BLOCCAGGIO (hydro)	LOCKING ROD (hydro)	TIGE DE BLOCAGE (hydro)	KLEMENSTANGE (hydro)
34	25394500/1	1	MANOPOLA	HANDLE	POINGEE	GRIFF
35	25430213/0	1	MOLLA	SPRING	RESSORT	FEDER
36	82000355/0	1	ASTA AGGANCIO SACCO SUP.	UPPER COUPLING ROD	TIGE D'ACCROCHAGE SUP.	OBERE KUPLUNGSTANGE
37	25510038/0	2	PERNO	PIN	PIVOT	BOLZEN



N.	CODE	Q.TY	DESCRIZIONE	DESCRIPTION	DESCRIPTION	BESCHREIBUNG
38	12521350/0	2	ROSETTA	WASHER	RONDELLE	SCHEIBE
39	12155000/0	2	DADO	NUT	ECROU	MUTTER
51	25600040/0	1	COPERCHIO PROTEZIONE	PROTECTION	PROTECTION	SHUTZ
52	25600039/0	1	PROTEZIONE MICRO	MICRO PROTECTION	PROTECTION MICRO	SCHUTZ
53	25318112/0	1	LEVA	LEVER	LEVIER	HEBEL
54	12400030/0	1	PERNO	PIN	PIVOT	BOLZEN
55	12728440/0	2	VITE	SCREW	VIS	SCHRAUBE

www.emc-motoculture.com

TC102

TC102 hy.

TC122 hy.

TCP102

TCP102 hy.

TCP122 hy.

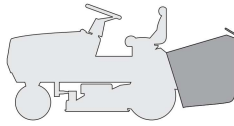

SACCO  
GRASSCATCHER  
BAC  
AUFFANGSACK

1999

011.0

1 / 2

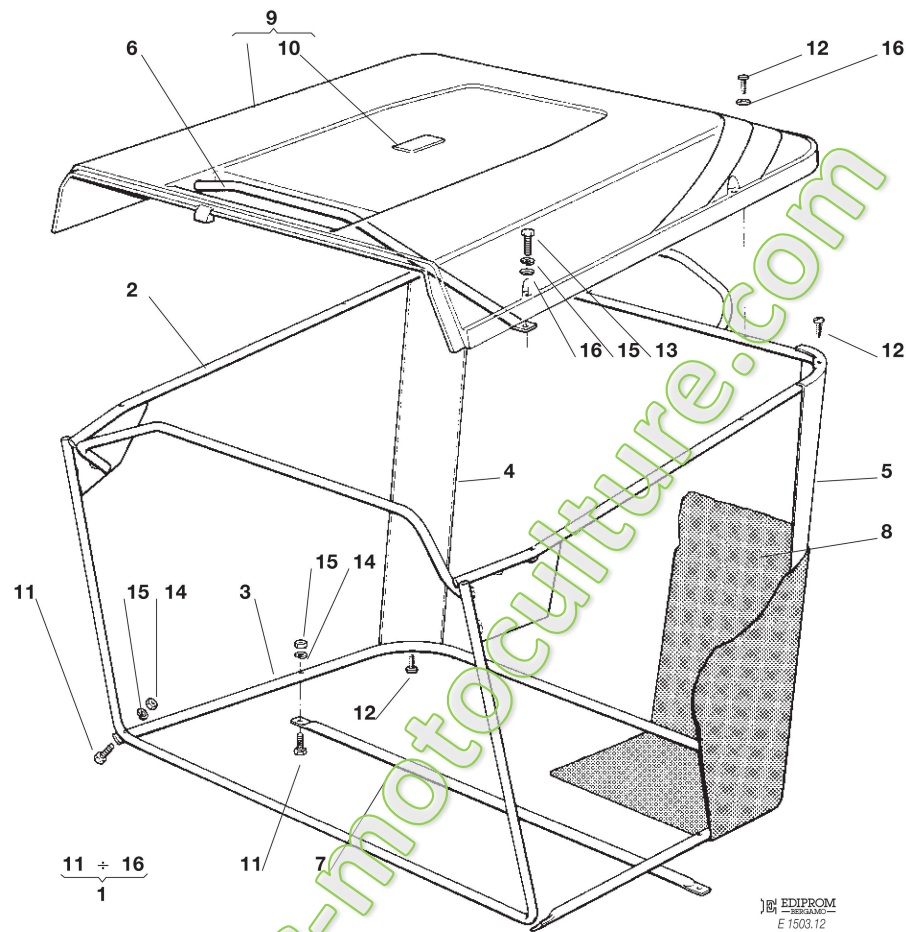

EDIPROM  
E 1503.12

N.	CODE	Q.TY	DESCRIZIONE	DESCRIPTION	DESCRIPTION	BESCHREIBUNG
1	82180000/2	1	DOTAZIONE SACCO	GRASS-BOX OUTFIT	DOTATION BAC	KORBAUS TATTUNG
2	82800008/0	1	TELAIO SUP.	UPPER FRAME	CHASSIS SUPERIEUR	OBERERRAHMEN
3	82800002/0	1	TELAIO INF.	LOWER FRAME	CHASSIS INFÉRIEUR	UNTERERRAHMEN
4	25032001/1	1	ANGOLARE DX	RIGHT ANGULAR SUPPORT	SUPPORT ANGULAIRE	RECHTER HALTER
5	25032002/1	1	ANGOLARE SX	LEFT ANGULAR SUPPORT	SUPPORT ANGULAIRE	LINKER HALTER
6	82394001/0	1	MANIGLIA ANT.	FRONT HANDLE	POIGNEE ANTERIEURE	VORDERGRIF
7	82650038/0	1	RINFORZO INF.	LOWER STIFFENING	RENFORCEMENT SUPER.	OBERE VERSTAERKUNG
8	82106000/1	1	SACCO	GRASSCATCHER	SAC	SACK
9	☛	1	COPERTURA SACCO (TC)	GRASSCAT. PLASTIC (TC)	SAC COUVERTURE (TC)	SACKABDECKUNG (TC)
	82110158/1		ROSSA	RED	ROUGE	ROT
	82110159/0		VERDE	GREEN)	VERT	GRÜN
	82110160/0		GIALLA	YELLOW	JAUNE	GELB
	82110161/0		BLU	BLUE	BLEU	BLAU
	☛	1	COPERTURA SACCO (TCP)	GRASSCAT. PLASTIC (TCP)	SAC COUVERTURE (TCP)	SACKABDECKUNG (TCP)
	82110170/0		ROSSA	RED	ROUGE	ROT
	82110171/0		VERDE	GREEN)	VERT	GRÜN
	82110172/0		GIALLA	YELLOW	JAUNE	GELB
	82110173/0		BLU	BLUE	BLEU	BLAU
10	☛	1	PIASTRINA (TC)	PLATE (TC)	PLAQUE (TC)	PLATTE (TC)
	25547016/1		ROSSA	RED	ROUGE	ROT
	25547015/0		VERDE	GREEN	VERT	GRÜN
	25547014/0		GIALLA	YELLOW	JAUNE	GELB
	25547024/0		BLU	BLUE	BLEU	BLAU
	☛	1	PIASTRINA (TCP)	PLATE (TCP)	PLAQUE (TCP)	PLATTE (TCP)
	25547025/0		ROSSA	RED	ROUGE	ROT
	25547026/0		VERDE	GREEN	VERT	GRÜN
	25547027/0		GIALLA	YELLOW	JAUNE	GELB
	25547028/0		BLU	BLUE	BLEU	BLAU
11	12792099/0	4	VITE	SCREW	VIS	SCHRAUBE



N.	CODE	Q.TY	DESCRIZIONE	DESCRIPTION	DESCRIPTION	BESCHREIBUNG
12	12729601/0	8	VITE	SCREW	VIS	SCHRAUBE
13	12674701/0	2	VITE	SCREW	VIS	SCHRAUBE
14	12292100/0	4	DADO	NUT	ECROU	MUTTER
15	12582101/0	6	GROWER	GROWER	GROWER	GROWER
16	12521331/0	6	RONDELLA	WASHER	RONDELLE	SCHEIBE

[www.emc-motoculture.com](http://www.emc-motoculture.com)

TC102

TC102 hy. TC122 hy.

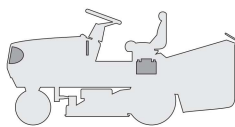

PARTI ELETTRICHE  
ELECTRICAL PARTS  
PARTIES ELECTRIQUES  
ELETRISCHETEILE

1999

012M.0

1 / 2

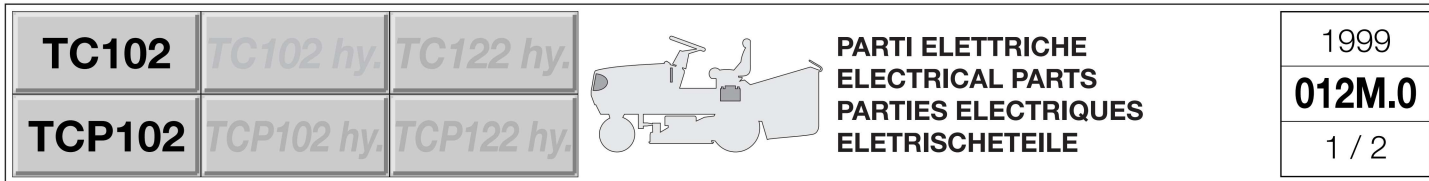

EDIPROM  
E 9850.11

N.	CODE	Q.TY	DESCRIZIONE	DESCRIPTION	DESCRIPTION	BESCHREIBUNG
1	18120002/1	1	BATTERIA 12 V - 18 Ah	BATTERY 12 V - 18 Ah	BATTERIE 12 V - 18 Ah	BATTERIE 12 V - 18 Ah
2	18564862/0	1	PROTEZIONE	PROTECTION	PROTECTION	SCHUTZ
3	25430200/0	2	MOLLA	SPRING	RESSORT	FEDER
4	18459100/0	2	LAMPADA	FARILAMP FOR LIGHTS	LAMPE POUR PHARES	LAMPENFASSUN
5	33500030/0	2	PORTALAMPADE	LAMP HOLDER	DOUILLE DE LAMPE	SCHEINWERFERLAMPE
6	18450060/0	1	INTERRUTTORE	FARILAMP SWITCH	INTERRUPTEUR PHARES	LICHTEN SCHALTER
7	18736110/0	1	SOLENOIDE	SOLENOID	SOLENOIDE	SOLENOID
8	12735110/0	2	VITE	SCREW	VIS	SCHRAUBE
10	18450065/1	1	INTERRUTTORE AVVIAMENTO	STARTING SWITCH	INTERRUPTEUR DEMARRAGE	SCHALTER
11	18400861/0	1	GHIERA	SCREWED RING	EMBOUT	NUTMUTTER
12	18565351/0	1	PROTEZIONE GHIERA	SCREWED RING PROTECTION	PROTECTION EMBOUT	NUTMUTTER SCHUTZ
13	18210016/0	1	CHIAVE AVVIAMENTO	STARTING KEY	CLEF A DEMARRAGE	SCHLÜSSEL FÜR START
14	19410603/1	4	MICRO INTERRUTTORE	MICRO	MICRO	MIKRO
15	***	1	SCHEDA ELETTRONICA	ELECTRONIC CARD	CARTE ELECTRONIQUE	ELEKTRONISCHE KARTE
16	25600007/0	1	PROTEZIONE SCHEDA (TC)	CARD PROTECTION (TC)	PROTECTION CARTE (TC)	KARTESCHUTZ (TC)
16	25600009/0	1	PROTEZIONE SCHEDA (TCP)	CARD PROTECTION (TCP)	PROTECTION CARTE (TCP)	KARTESCHUTZ (TCP)
18	12735105/0	3	VITE	SCREW	VIS	SCHRAUBE
19	25420000/1	1	MEMBRANA (6 FUNZ.)	CHECK CONTROLL (6 FUNCTIONS)	PANNEAU DE CONTROLE (6 INDICATIONS)	KONTROLLTAFEL (6 ANGABEN)
	25420001/1	1	MEMBRANA (8 FUNZ.)	CHECK CONTROLL (8 FUNCTIONS)	PANNEAU DE CONTROLE (8 INDICATIONS)	KONTROLLTAFEL 1 (8 ANGABEN)
20	33340033/0	1	FUSIBILE 6,3 Amp. T	FUSE 6.3 Amp. T	FUSIBLE 6,3 Amp. T	SICHERUNG 6,3 Amp. T
21	19410604/0	1	INTERRUTTORE CAMBIO	GEARBOX SWITCH	INT. BOÎTE DE VITESSE	ANTRIEB SCHALTER
22	19410605/1	1	MICRO SACCO PIENO MICROSWITCH	FULL GRASSCATCHER	MICRO BAC PLEIN	VOLLKORB VORRICHTUNG
23	☛	1	ASS. CABLAGGIO	CABLES ASS.Y	ENS. CABLAGES	KABELSATZ
	82040024/0		12,5 - 13 HP B&S	12,5 - 13 HP B&S	12,5 - 13 HP B&S	12,5 - 13 HP B&S
			13 - 15 HP TECUMSEH	13 - 15 HP TECUMSEH	13 - 15 HP TECUMSEH	13 - 15 HP TECUMSEH
	82040026/0		16 HP B&S	16 HP B&S	16 HP B&S	16 HP B&S
	82040025/0		15,5HP B&S	15,5HP B&S	15,5HP B&S	15,5HP B&S



N.	CODE	Q.TY	DESCRIZIONE	DESCRIPTION	DESCRIPTION	BESCHREIBUNG
24	82040004/1	1	ASS. CABLAGGIO 12,5 - 13 - 15,5 HP B&S 13 - 15 HP TECUMSEH	CABLES ASS.Y 12,5 - 13 - 15,5 HP B&S 13 - 15 HP TECUMSEH	ENS. CABLAGES 12,5 - 13 - 15,5 HP B&S 13 - 15 HP TECUMSEH	KABELSATZ 12,5 - 13 - 15,5 HP B&S 13 - 15 HP TECUMSEH
	82040005/2		16 - 18 HP B&S	16 - 18 HP B&S	16 - 18 HP B&S	16 - 18 HP B&S
25	25065003/0	1	ASS. CABLAGGIO	CABLES ASS.Y	ENS. CABLAGES	KABELSATZ
26	25065004/0	1	CAVO RICARICA	CABLE	CABLES	KABEL
27	25065004/0	1	CAVO MASSA BATTERIA	CABLE	CABLES	KABEL
28	25065001/0	1	CAVO BATT. SOLENOIDE	CABLE	CABLES	KABEL
29	25065002/0	1	CAVO SOLENOIDE MOT.	CABLE	CABLES	KABEL
31	12360352/0	2	DADO	NUT	ECROU	MUTTER
32	25065005/0	1	CAVO MASSA	CABLE	CABLES	KABEL
33	12540260/0	1	RONDELLA	WASHER	RONDELLE	SCHLEIBE
34	25065003/0	1	CAVO COLL. MICRO	CABLE	CABLES	KABEL
35	18564861/0	1	CAPPUCCIO PROTEZIONE	PROTECTION	PROTECTION	SCHUTZ
36	33320505/0	1	FERMACAVO	FAIRLED	FIXATION CABLE	KABELBEFESTIGUNG
37	33320506/0	2	FERMACAVO	FAIRLED	FIXATION CABLE	KABELBEFESTIGUNG
38	18230000/0	1	CONTAORE (TCP)	HOUR COUNTER (TCP)	COMPTE-HEURS (TCP)	BETRIEBESSTUNDENZÄHLER (TCP)
39	25065009/0	1	CAVO (TCP)	CABLE (TCP)	CABLES (TCP)	KABEL (TCP)
40	25065010/1	1	CAVO (TCP)	CABLE (TCP)	CABLES (TCP)	KABEL (TCP)
41	25785010/0	1	SUPPORTO BATTERIA	BATTERY HOLDER	SUPPORT BATTERIE	BATTERIE STÜTZE
42	25065023/0	1	CAVO	CABLE	CABLES	KABEL

\*\*\* PER I PARTICOLARI CONTRASSEGNAI, VERIFICARE L'ALLESTIMENTO DEL TRATTORE:  
 FOR THE MARKED ITEMS, PLEASE CHECK TRACTOR'S VERSION:  
 POUR LES PIÈCES MARQUÉES, VÉRIFIEZ LA VERSION DE L'AUTOPORTÉE:  
 FÜR KENNENZEICHNETEN TEILE, BITTE PRÜFEN SIE DER AUFSTZMAßER AUSSTATTUNG:

a) **Motore 12,5 - 13 - 15,5 HP B&S, 13 - 15 HP Tecumseh + Interruttore cambio (21) + Micro sacco pieno (22)**  
**Engine 12,5 - 13 - 15,5 HP B&S, 13 - 15 HP Tecumseh + Gearbox switch (21) + Full grasscatcher micriswitch (22)**  
**Moteur 12,5 - 13 - 15,5 HP B&S, 13 - 15 HP Tecumseh + Interrupteur boîte de vitesse (21) + Micro bac plein (22)**  
**Motor 12,5 - 13 - 15,5 HP B&S, 13 - 15 HP Tecumseh + Antrieb Schalter (21) + Vollkorb Vorrichtung (22)**

15	25722406/0	1	SCHEDA ELETTRONICA 6 FUNZIONI	ELECTRONIC CARD 6 FUNCTIONS	CARTE ELECTRONIQUE 6 INDICAT	ELEKTRONISCHE KARTE 6 ANGABEN
25	82040029/1	1	ASS. CABLAGGIO	CABLES ASS.Y	ENS. CABLAGES	KABELSATZ
34	25065011/0	1	CAVO COLL. MICRO	CABLE	CABLES	KABEL

b) **Motore 16 - 18 HP B&S + Interruttore cambio (21) + Micro sacco pieno (22)**  
**Engine 16 - 18 HP B&S + Gearbox switch (21) + Full grasscatcher micriswitch (22)**  
**Moteur 16 - 18 HP B&S + Interrupteur boîte de vitesse (21) + Micro bac plein (22)**  
**Motor 16 - 18 HP B&S + Antrieb Schalter (21) + Vollkorb Vorrichtung (22)**

15	25722407/0	1	SCHEDA ELETTRONICA 8 FUNZIONI	ELECTRONIC CARD 8 FUNCTIONS	CARTE ELECTRONIQUE 8 INDICAT	ELEKTRONISCHE KARTE 8 ANGABEN
25	82040028/1	1	ASS. CABLAGGIO	CABLES ASS.Y	ENS. CABLAGES	KABELSATZ
34	25065011/0	1	CAVO COLL. MICRO	CABLE	CABLES	KABEL

TC102

TC102 hy. TC122 hy.

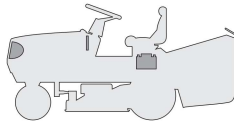

PARTI ELETTRICHE  
ELECTRICAL PARTS  
PARTIES ELECTRIQUES  
ELETRISCHETEILE

1999

012Y.0

1 / 2

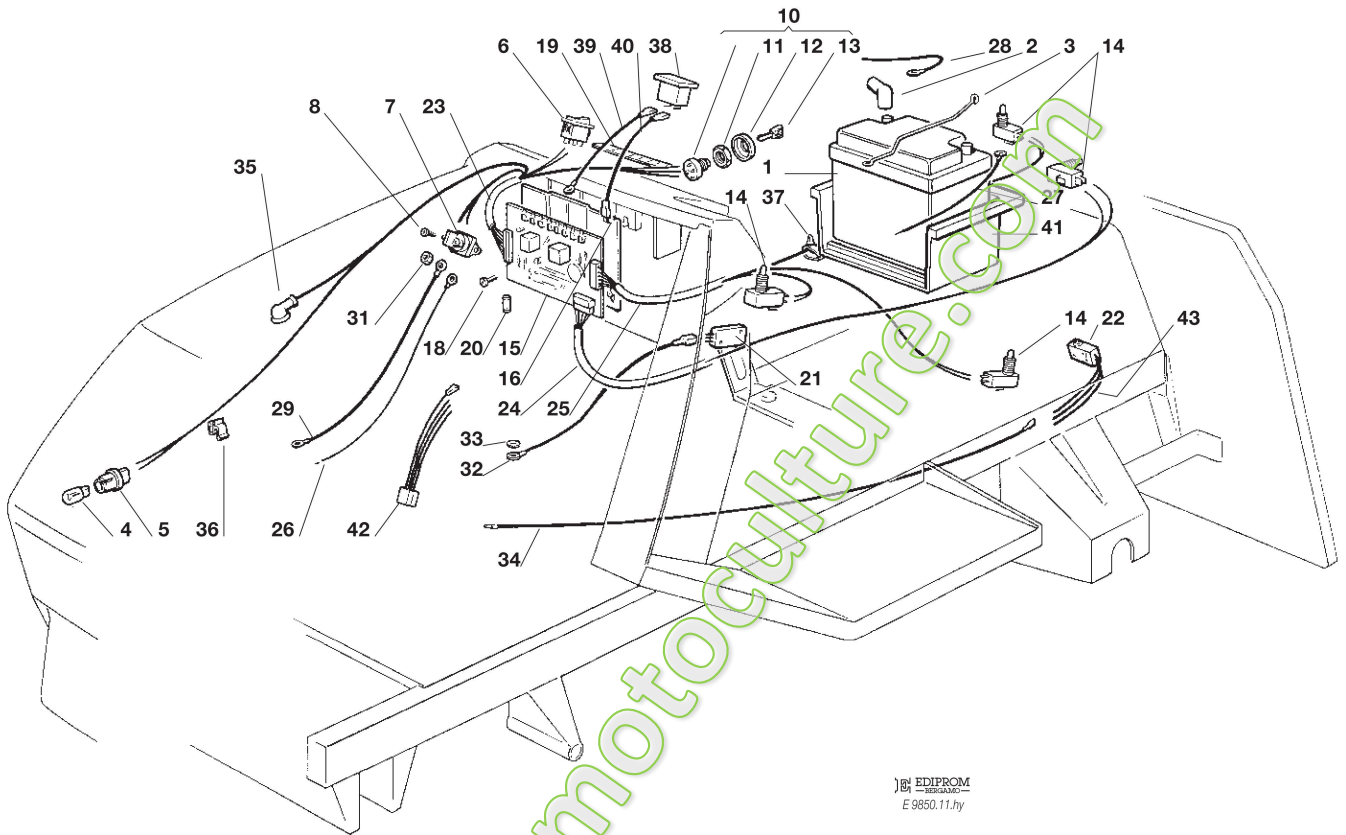

EDIPROM  
E 9850.11.hy

N.	CODE	Q.TY	DESCRIZIONE	DESCRIPTION	DESCRIPTION	BESCHREIBUNG
1	18120002/1	1	BATTERIA 12 V - 18 Ah	BATTERY 12 V - 18 Ah	BATTERIE 12 V - 18 Ah	BATTERIE 12 V - 18 Ah
2	18564862/0	1	PROTEZIONE	PROTECTION	PROTECTION	SCHUTZ
3	25430200/0	2	MOLLA	SPRING	RESSORT	FEDER
4	18459100/0	2	LAMPADA	FARILAMP FOR LIGHTS	LAMPE POUR PHARES	LAMPENFASSUN
5	33500030/0	2	PORTALAMPADE	LAMP HOLDER	DOUILLE DE LAMPE	SCHEINWERFERLAMPE
6	18450060/0	1	INTERRUTTORE	FARILAMP SWITCH	INTERRUPTEUR PHARES	LICHTEN SCHALTER
7	18736110/0	1	SOLENOIDE	SOLENOID	SOLENOIDE	SOLENOID
8	12735110/0	2	VITE	SCREW	VIS	SCHRAUBE
10	18450065/1	1	INTERRUTTORE AVVIAMENTO	STARTING SWITCH	INTERRUPTEUR DEMARRAGE	SCHALTER
11	18400861/0	1	GHIERA	SCREWED RING	EMBOUT	NUTMUTTER
12	18565351/0	1	PROTEZIONE GHIERA	SCREWED RING PROTECTION	PROTECTION EMBOUT	NUTMUTTER SCHUTZ
13	18210016/0	1	CHIAVE AVVIAMENTO	STARTING KEY	CLEF A DEMARRAGE	SCHLÜSSEL FÜR START
14	19410603/1	4	MICRO INTERRUTTORE	MICRO	MICRO	MIKRO
15	***	1	SCHEDA ELETTRONICA	ELECTRONIC CARD	CARTE ELECTRONIQUE	ELEKTRONISCHE KARTE
16	25600007/0	1	PROTEZIONE SCHEDA (TC)	CARD PROTECTION (TC)	PROTECTION CARTE (TC)	KARTESCHUTZ (TC)
16	25600009/0	1	PROTEZIONE SCHEDA (TCP)	CARD PROTECTION (TCP)	PROTECTION CARTE (TCP)	KARTESCHUTZ (TCP)
18	12735105/0	3	VITE	SCREW	VIS	SCHRAUBE
19	25420000/1	1	MEMBRANA (6 FUNZ.)	CHECK CONTROLL (6 FUNCTIONS)	PANNEAU DE CONTROLE (6 INDICATIONS)	KONTROLLTAFEL (6 ANGABEN)
	25420001/1	1	MEMBRANA (8 FUNZ.)	CHECK CONTROLL (8 FUNCTIONS)	PANNEAU DE CONTROLE (8 INDICATIONS)	KONTROLLTAFEL (8 ANGABEN)
20	33340033/0	1	FUSIBILE 6,3 Amp. T	FUSE 6.3 Amp. T	FUSIBLE 6,3 Amp. T	SICHERUNG 6,3 Amp. T
21	19410609/0	1	INTERRUT. POS. FOLLE	NEUTRAL SWITCH	INTERRUPT. POINT MORT	LEERLAUF SCHALTER
22	19410605/1	1	MICRO SACCO PIENO MICROSWITCH	FULL GRASSCATCHER	MICRO BAC PLEIN	VOLLKORB VORRICHTUNG
23	☛	1	ASS. CABLAGGIO	CABLES ASS.Y	ENS. CABLAGES	KABELSATZ
	82040046/0		12,5 - 13 HP B&S 13 - 15 HP TECUMSEH	12,5 - 13 HP B&S 13 - 15 HP TECUMSEH	12,5 - 13 HP B&S 13 - 15 HP TECUMSEH	12,5 - 13 HP B&S 13 - 15 HP TECUMSEH
	82040035/0		16 - 18 HP B&S	16 - 18 HP B&S	16 - 18 HP B&S	16 - 18 HP B&S
	82040034/0		15,5HP B&S	15,5HP B&S	15,5HP B&S	15,5HP B&S



N.	CODE	Q.TY	DESCRIZIONE	DESCRIPTION	DESCRIPTION	BESCHREIBUNG
24	82040004/1	1	ASS. CABLAGGIO 12,5 - 13 - 15,5 HP B&S 13 - 15 HP TECUMSEH	CABLES ASS.Y 12,5 - 13 - 15,5 HP B&S 13 - 15 HP TECUMSEH	ENS. CABLAGES 12,5 - 13 - 15,5 HP B&S 13 - 15 HP TECUMSEH	KABELSATZ 12,5 - 13 - 15,5 HP B&S 13 - 15 HP TECUMSEH
	82040005/2		16 - 18 HP B&S	16 - 18 HP B&S	16 - 18 HP B&S	16 - 18 HP B&S
25	25065003/0	1	ASS. CABLAGGIO	CABLES ASS.Y	ENS. CABLAGES	KABELSATZ
26	25065004/0	1	CAVO RICARICA	CABLE	CABLES	KABEL
27	25065004/0	1	CAVO MASSA BATTERIA	CABLE	CABLES	KABEL
28	25065001/0	1	CAVO BATT. SOLENOIDE	CABLE	CABLES	KABEL
29	25065002/0	1	CAVO SOLENOIDE MOT.	CABLE	CABLES	KABEL
30	12583500/0	2	GROWER	GROWER	GROWER	GROWER
31	12360352/0	2	DADO	NUT	ECROU	MUTTER
32	25065015/0	1	CAVO MASSA	CABLE	CABLES	KABEL
33	12540260/0	1	RONDELLA	WASHER	RONDELLE	SCHEIBE
34	25065011/0	1	CAVO COLL. MICRO	CABLE	CABLES	KABEL
35	18564861/0	1	CAPPUCCIO PROTEZIONE	PROTECTION	PROTECTION	SCHUTZ
36	33320505/0	1	FERMACAVO	FAIRLED	FIXATION CABLE	KABELBEFESTIGUNG
37	33320506/0	2	FERMACAVO	FAIRLED	FIXATION CABLE	KABELBEFESTIGUNG
38	18230000/0	1	CONTAORE (TCP)	HOUR COUNTER (TCP)	COMPTE-HEURS (TCP)	BETRIEBESSTUNDENZÄHLER (TCP)
39	25065009/0	1	CAVO (TCP)	CABLE (TCP)	CABLES (TCP)	KABEL (TCP)
40	25065010/1	1	CAVO (TCP)	CABLE (TCP)	CABLES (TCP)	KABEL (TCP)
41	25785010/0	1	SUPPORTO BATTERIA	BATTERY HOLDER	SUPPORT BATTERIE	BATTERIE STÜTZE
42	82180025/0	1	INTERFACCIA	INTERFACE	INTERFACE	INTERFACE
43	25065023/0	1	CAVO	CABLE	CABLES	KABEL

\*\*\* PER I PARTICOLARI CONTRASSEGNA TI, VERIFICARE L'ALLESTIMENTO DEL TRATTO RINO:  
 FOR THE MARKED ITEMS, PLEASE CHECK TRACTOR'S VERSION:  
 POUR LES PI ECES MARQUEES, VERIFIEZ LA VERSION DE L'AUTO PORTEE:  
 FÜR KENNENGEZEICHNETEN TEILE, BITTE PRÜFEN SIE DER AUFSITZMÄHERAUSSTATTUNG:

a) Motore 12,5 - 13 - 15,5 HP B&S, 13 - 15 - 17 HP Tecumseh + Interruttore posizione folle (21) + Micro sacco pieno (22)  
 Engine 12,5 - 13 - 15,5 HP B&S, 13 - 15 - 17 HP Tecumseh + Neutral switch (21) + Full grasscatcher micriswitch (22)  
 Moteur 12,5 - 13 - 15,5 HP B&S, 13 - 15 - 17 HP Tecumseh + Interrupteur point mort (21) + Micro bac plein (22)  
 Motor 12,5 - 13 - 15,5 HP B&S, 13 - 15 - 17 HP Tecumseh + Leerlaufstellung Schalter (21) + Vollkorb Vorrichtung (22)

15	25722406/0	1	SCHEDA ELETTRONICA 6 FUNZIONI	ELECTRONIC CARD 6 FUNCTIONS	CARTE ELECTRONIQUE 6 INDICAT	ELEKTRONISCHE KARTE 6 ANGABEN
25	82040029/1	1	ASS. CABLAGGIO	CABLES ASS.Y	ENS. CABLAGES	KABELSATZ
34	25065011/0	1	CAVO COLL. MICRO	CABLE	CABLES	KABEL

b) Motore 16 - 18 HP B&S + Interruttore posizione folle (21) + Micro sacco pieno (22)  
 Engine 16 - 18 HP B&S + Neutral switch (21) + Full grasscatcher micriswitch (22)  
 Moteur 16 - 18 HP B&S + Interrupteur point mort (21) + Micro bac plein (22)  
 Motor 16 - 18 HP B&S + Leerlaufstellung Schalter (21) + Vollkorb Vorrichtung (22)

15	25722407/0	1	SCHEDA ELETTRONICA 8 FUNZIONI	ELECTRONIC CARD 8 FUNCTIONS	CARTE ELECTRONIQUE 8 INDICAT	ELEKTRONISCHE KARTE 8 ANGABEN
25	82040028/1	1	ASS. CABLAGGIO	CABLES ASS.Y	ENS. CABLAGES	KABELSATZ
34	25065011/0	1	CAVO COLL. MICRO	CABLE	CABLES	KABEL

TC102

TC102 hy. TC122 hy.

TCP102

TCP102 hy. TCP122 hy.

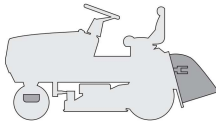

ACCESSORI A RICHIESTA  
OPTIONALS ON REQUEST  
ACCESSOIRES SUR DEMANDE  
ZUBEHOERE NACH ANFRAGE

1999

013.0

1 / 1

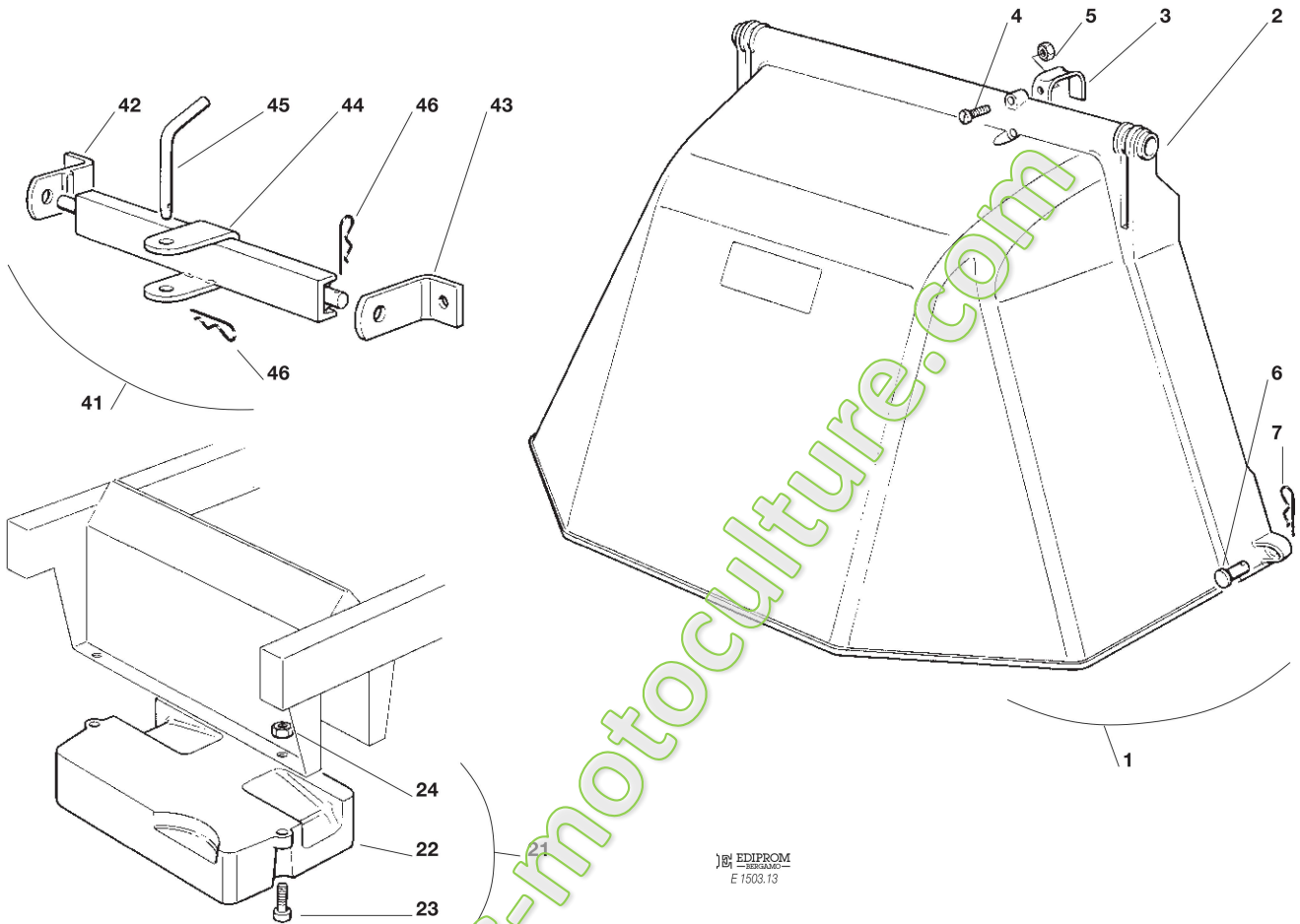

EDIPROM  
E 1503.13

N.	CODE	Q.TY	DESCRIZIONE	DESCRIPTION	DESCRIPTION	BESCHREIBUNG
1	99900010/1	1	ASS. KIT PROTEZIONE USCITA	EJECTION-GUARD ASS.Y	KIT PROTECTION SORTIE	VORRICHTUNG FÜR AUSWURESCHUTZ
2	82400001/1	1	PROTEZIONE USCITA	EJECTION GUARD	PROTECTION SORTIE	AUSWURFSCHUTZ
3	25430216/0	1	MOLLA	SPRING	RESSORT	FEDER
4	12769100/0	2	VITE	SCREW	VIS	SCHRAUBE
5	12150000/0	1	DADO	NUT	ECROU	MUTTER
6	25510022/0	2	PERNO	PIN	PIVOT	BOLZEN
7	24487998/0	2	COPPIGLIA	COTTER PIN	GOUPILLE	SPLIT
21	99900030/4	1	ASS. KIT PESO ANT.	FRONT WEIGHT KIT	KIT POIDS ANTERIEUR	VORDERGEWICHT VORRICHTUNG
22	25519999/4	1	PESO	WEIGHT	POIDS	GEWICHT
23	12760512/0	3	VITE	SCREW	VIS	SCHRAUBE
24	12155000/0	3	DADO	NUT	ECROU	MUTTER
41	99900000/0	1	ASS. KIT TRAINO	HITCH KIT	KIT DE TRAINAGE	ZUGVORRICHTUNG
42	82735502/0	1	STAFFA SUPPORTO TRAINO DX	BRACKET RIGHT HITCH SUPPORT	ETRIER SUPPORT TRAINAGE DROITE	BUEGEL HALTER FÜR RECHTEN ZUG
43	25774213/0	1	STAFFA SUPPORTO TRAINO SX	BRACKET LEFT HITCH SUPPORT	ETRIER SUPPORT TRAINAGE GAUCHE	BUEGELHALTER FÜR LINKEN ZUG
44	82033101/0	1	BARRA	ROD	BARRE	STANGE
45	25510021/0	1	PERNO	PIN	PIVOT	BOLZEN
46	24487999/0	2	COPPIGLIA	COTTER PIN	GOUPILLE	SPLIT
-	18737950/0	1	TELO DI COPERTURA	CLOTH	BÂCHE	PLANE

**TC102**

TC102 hy.

TC122 hy.

**SCHEMA ELETTRICO  
WIRE DIAGRAM  
SCHEMA ELECTRIQUE  
ELEKTRISCHE SCHEMA**

**12,5 - 13 HP B&S, 13 - 15 HP TECUMSEH**

1999

**014M.0**

1 / 1

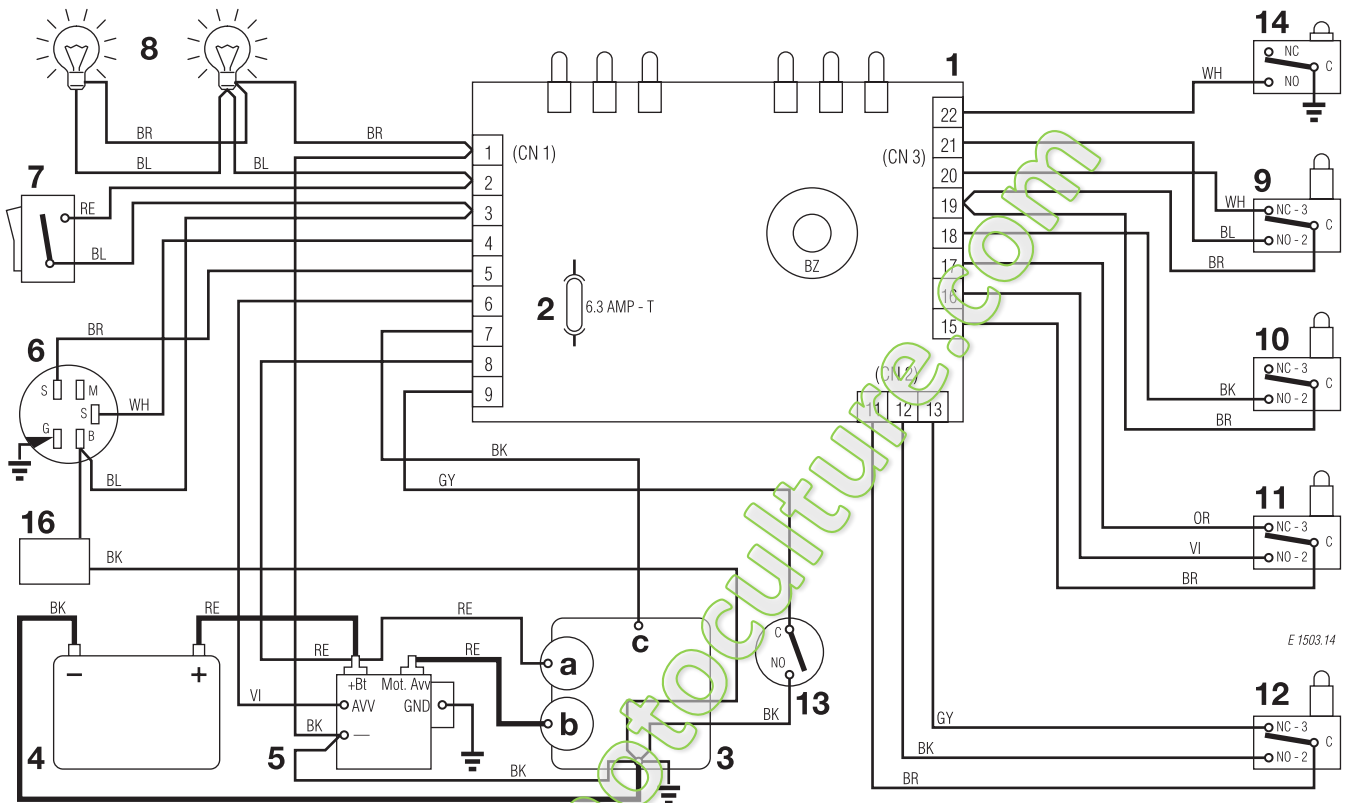

<b>1</b>	SCHEDA CON BUZZER	ELECTRONIC CARD WITH BUZZER	CARTE ELECTRONIQUE AVEC BUZZER	ELECTRONISCHE KARTE MIT BUZZER
<b>2</b>	FUSIBILE 6,3 Amp. T	FUSE 6.3 Amp. T	FUSIBLE 6,3 Amp. T	SICHERUNG 6,3 Amp. T
<b>3</b>	MOTORE	ENGINE	MOTEUR	MOTOR
<b>3a</b>	Generatore	Generator	Generateur	Generator
<b>3b</b>	Motorino avviamento	Starter	Demarreur	Anlasser
<b>3c</b>	Stop motore	Engine stop	Calage du moteur	Motor abstellung
<b>4</b>	BATTERIA	BATTERY	BATTERIE	BATTERIE
<b>5</b>	RELE AVVIAMENTO	STARTER RELAY	RELAIS DE DEMARRAGE	ANLASSER RELAIS
<b>6</b>	INTERRUTTORE A CHIAVE	ELECTROLOCK	INTERRUPTEUR D'ALLUMAGE	SCHLÜSSELSCHALTER
<b>7</b>	INTERRUTTORE FARI	HEADLIGHT SWITCH	INTERRUPTEUR PHARES	LICHTSCHALTER
<b>8</b>	FARI	HEADLIGHT	PHARES	LICHT
<b>9</b>	MICROINTERRUTTORE LAME	BLADES MICRO SWITCH	MICRO INTERRUPTEUR LAMES	MESSER MIKROSCHALTER
<b>10</b>	MICROINTERRUTTORE FRENO	BRAKE MICRO SWITCH	MICRO INTERRUPTEUR FREIN	BREMSE MIKROSCHALTER
<b>11</b>	MICROINTERRUTTORE SEDILE	SEAT MICRO SWITCH	MICRO INTERRUPTEUR SIEGE	SITZMIKROSCHALTER
<b>12</b>	MICROINTERRUTTORE SACCO	GRASSCATCHER MICRO SWITCH	MICRO INTERRUPTEUR BAC	GRASFANGEINRICHTUNG MIKROSCHALTER
<b>13</b>	MICROINTERRUTTORE CAMBIO	GERARBOX MICROSWITCH	MICRO INT. BOÎTE DE VITESSE	ANTRIEB MICROSWITCH
<b>14</b>	MICROINTERRUTTORE SACCO PIENO	FULL GRASSCATCHER MICRO SWITCH	MICRO BAC PLEIN	VOLLKORB VORRICHTUNG
<b>16</b>	CONTAORE (TCP)	HOUR COUNTER (TCP)	COMPTE-HEURS (TCP)	BETRIEBESSTUNDENZÄHLER (TCP)

**COLORI CAVI**

<b>BK</b>	NERO
<b>BL</b>	BLU
<b>BR</b>	MARRONE
<b>GY</b>	GRIGIO
<b>OR</b>	ARANCIONE
<b>RE</b>	ROSSO
<b>VI</b>	VIOLA
<b>YG</b>	GIALLO/VERDE
<b>WH</b>	BIANCO

**CABLE COLOURS**

<b>BLACK</b>
<b>BLUE</b>
<b>BROWN</b>
<b>GREY</b>
<b>ORANGE</b>
<b>RED</b>
<b>VIOLET</b>
<b>YELLOW/GREEN</b>
<b>WHITE</b>

**COULEUR CABLES**

<b>NOIR</b>
<b>BLEU</b>
<b>BUN</b>
<b>GRIS</b>
<b>ORANGE</b>
<b>ROUGE</b>
<b>VIOLEY</b>
<b>JAUNE/VERT</b>
<b>BLANC</b>

**KABEL FARBEN**

<b>SCHWARZ</b>
<b>BLAU</b>
<b>BRAUN</b>
<b>GRAU</b>
<b>ORANGE</b>
<b>ROT</b>
<b>VIOLETT</b>
<b>GELB/GRÜN</b>
<b>WEISS</b>

**TC102**

TC102 hy.

TC122 hy.

**SCHEMA ELETTRICO  
WIRE DIAGRAM  
SCHEMA ELECTRIQUE  
ELEKTRISCHE SCHEMA  
15,5 HP B&S**

1999

**014Ma.0**

1 / 1

**TCP102** TCP102 hy. TCP122 hy.

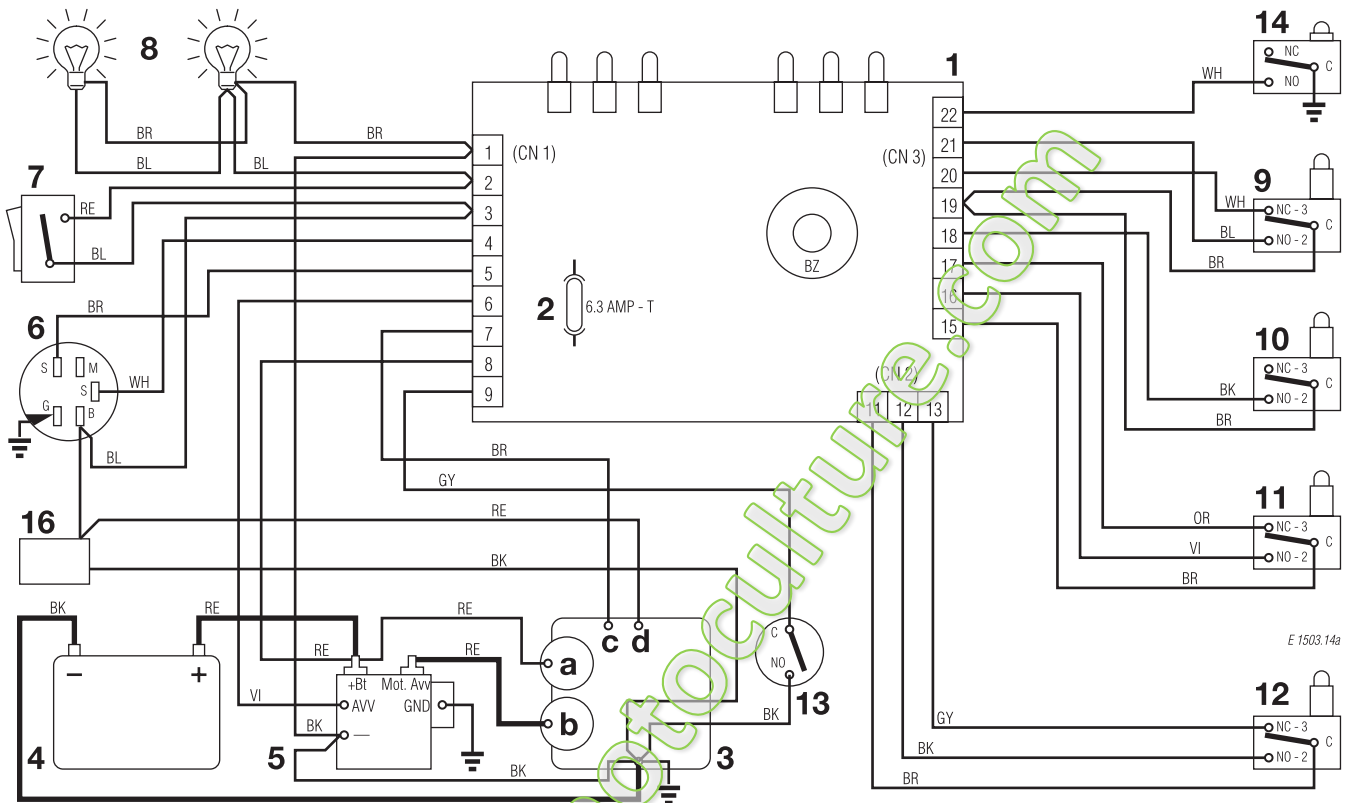

<b>1</b>	SCHEDA CON BUZZER	ELECTRONIC CARD WITH BUZZER	CARTE ELECTRONIQUE AVEC BUZZER	ELECTRONISCHE KARTE MIT BUZZER
<b>2</b>	FUSIBILE 6,3 Amp. T	FUSE 6.3 Amp. T	FUSIBLE 6,3 Amp. T	SICHERUNG 6,3 Amp. T
<b>3</b>	MOTORE	ENGINE	MOTEUR	MOTOR
<b>3a</b>	Generatore	Generator	Generateur	Generator
<b>3b</b>	Motorino avviamento	Starter	Demarreur	Anlasser
<b>3c</b>	Stop motore	Engine stop	Calage du moteur	Motor abstellung
<b>3d</b>	Carburatore	Carburetor	Carburateur	Vergaser
<b>4</b>	BATTERIA	BATTERY	BATTERIE	BATTERIE
<b>5</b>	RELE AVVIAMENTO	STARTER RELAY	RELAIS DE DEMARRAGE	ANLASSER RELAIS
<b>6</b>	INTERRUTTORE A CHIAVE	ELECTROLOCK	INTERRUPTEUR D'ALLUMAGE	SCHLÜSSELSCHALTER
<b>7</b>	INTERRUTTORE FARI	HEADLIGHT SWITCH	INTERRUPTEUR PHARES	LICHTSCHALTER
<b>8</b>	FARI	HEADLIGHT	PHARES	LICHT
<b>9</b>	MICROINTERRUTTORE LAME	BLADES MICRO SWITCH	MICRO INTERRUPTEUR LAMES	MESSER MIKROSCHALTER
<b>10</b>	MICROINTERRUTTORE FRENO	BRAKE MICRO SWITCH	MICRO INTERRUPTEUR FREIN	BREMSE MIKROSCHALTER
<b>11</b>	MICROINTERRUTTORE SEDILE	SEAT MICRO SWITCH	MICRO INTERRUPTEUR SIEGE	SITZMIKROSCHALTER
<b>12</b>	MICROINTERRUTTORE SACCO	GRASSCATCHER MICRO SWITCH	MICRO INTERRUPTEUR BAC	GRASFANGEINRICHTUNG MIKROSCHALTER
<b>13</b>	MICROINTERRUTTORE CAMBIO	GERARBOX MICROSWITCH	MICRO INT. BOÎTE DE VITESSE	ANTRIEB MICROSWITCH
<b>14</b>	MICROINTERRUTTORE SACCO PIENO	FULL GRASSCATCHER MICRO SWITCH	MICRO BAC PLEIN	VOLLKORB VORRICHTUNG
<b>16</b>	CONTAORE (TCP)	HOUR COUNTER (TCP)	COMPTE-HEURS (TCP)	BETRIEBESSTUNDENZÄHLER (TCP)

**COLORI CAVI**

<b>BK</b>	NERO
<b>BL</b>	BLU
<b>BR</b>	MARRONE
<b>GY</b>	GRIGIO
<b>OR</b>	ARANCIONE
<b>RE</b>	ROSSO
<b>VI</b>	VIOLA
<b>YG</b>	GIALLO/VERDE
<b>WH</b>	BIANCO

**CABLE COLOURS**

<b>BLACK</b>
<b>BLUE</b>
<b>BROWN</b>
<b>GREY</b>
<b>ORANGE</b>
<b>RED</b>
<b>VIOLET</b>
<b>YELLOW/GREEN</b>
<b>WHITE</b>

**COULEUR CABLES**

<b>NOIR</b>
<b>BLEU</b>
<b>BUN</b>
<b>GRIS</b>
<b>ORANGE</b>
<b>ROUGE</b>
<b>VIOLEY</b>
<b>JAUNE/VERT</b>
<b>BLANC</b>

**KABEL FARBEN**

<b>SCHWARZ</b>
<b>BLAU</b>
<b>BRAUN</b>
<b>GRAU</b>
<b>ORANGE</b>
<b>ROT</b>
<b>VIOLETT</b>
<b>GELB/GRÜN</b>
<b>WEISS</b>

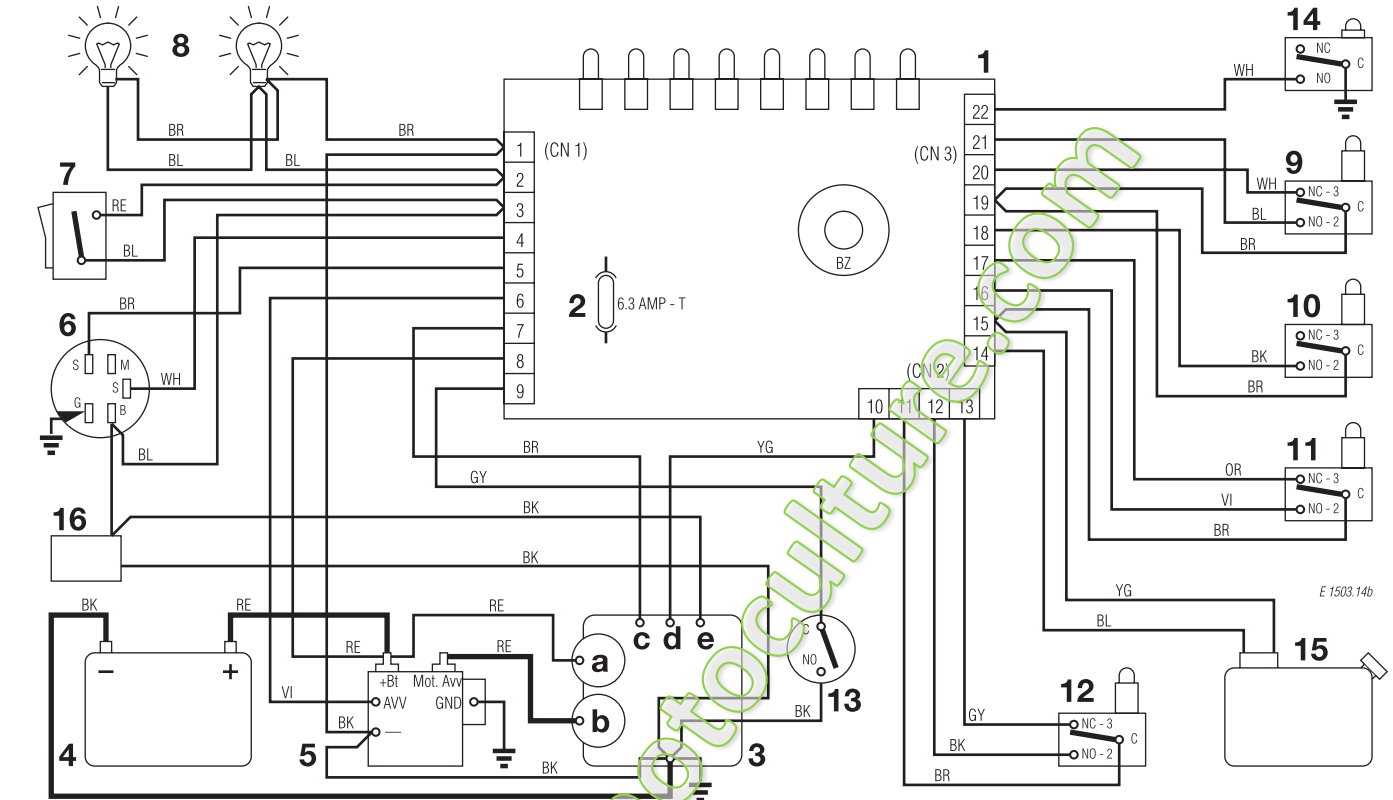

1	SCHEDA CON BUZZER	ELECTRONIC CARD WITH BUZZER	CARTE ELECTRONIQUE AVEC BUZZER	ELECTRONISCHE KARTE MIT BUZZER
2	FUSIBILE 6,3 Amp. T	FUSE 6.3 Amp. T	FUSIBLE 6,3 Amp. T	SICHERUNG 6,3 Amp. T
3	MOTORE	ENGINE	MOTEUR	MOTOR
3a	Generatore	Generator	Generateur	Generator
3b	Motorino avviamento	Starter	Demarreur	Anlasser
3c	Stop motore	Engine stop	Calage du moteur	Motor abstellung
3d	Olio	Oil	Huile	Öl
3e	Carburatore	Carburetor	Carburateur	Vergaser
4	BATTERIA	BATTERY	BATTERIE	BATTERIE
5	RELE AVVIAMENTO	STARTER RELAY	RELAIS DE DEMARRAGE	ANLASSER RELAIS
6	INTERRUTTORE A CHIAVE	ELECTROLOCK	INTERRUPTEUR D'ALLUMAGE	SCHLÜSSELSCHALTER
7	INTERRUTTORE FARI	HEADLIGHT SWITCH	INTERRUPTEUR PHARES	LICHTSCHALTER
8	FARI	HEADLIGHT	PHARES	LICHT
9	MICROINTERRUTTORE LAME	BLADES MICRO SWITCH	MICRO INTERRUPTEUR LAMES	MESSER MIKROSCHALTER
10	MICROINTERRUTTORE FRENO	BRAKE MICRO SWITCH	MICRO INTERRUPTEUR FREIN	BREMSE MIKROSCHALTER
11	MICROINTERRUTTORE SEDILE	SEAT MICRO SWITCH	MICRO INTERRUPTEUR SIEGE	SITZMIKROSCHALTER
12	MICROINTERRUTTORE SACCO	GRASSCATCHER MICRO SWITCH	MICRO INTERRUPTEUR BAC	GRASFANGEINRICHTUNG MIKROSCHALTER
13	MICROINTERRUTTORE CAMBIO	GERARBOX MICROSWITCH	MICRO INT. BOÎTE DE VITESSE	ANTRIEB MICROSWITCH
14	MICROINTERRUTTORE SACCO PIENO	FULL GRASSCATCHER MICRO SWITCH	MICRO BAC PLEIN	VOLLKORB VORRICHTUNG
15	SERBATOIO	TANK	RESERVIOR	TANK
16	CONTAORE (TCP)	HOUR COUNTER (TCP)	COMPTE-HEURS (TCP)	BETRIEBESSTUNDENZÄHLER (TCP)

**COLORI CAVI**

BK	NERO
BL	BLU
BR	MARRONE
GY	GRIGIO
OR	ARANCIONE
RE	ROSSO
VI	VIOLA
YG	GIALLO/VERDE
WH	BIANCO

**CABLE COLOURS**

BLACK
BLUE
BROWN
GREY
ORANGE
RED
VIOLET
YELLOW/GREEN
WHITE

**COULEUR CABLES**

NOIR
BLEU
BUN
GRIS
ORANGE
ROUGE
VIOLEY
JAUNE/VERT
BLANC

**KABEL FARBEN**

SCHWARZ
BLAU
BRAUN
GRAU
ORANGE
ROT
VIOLETT
GELB/GRÜN
WEISS

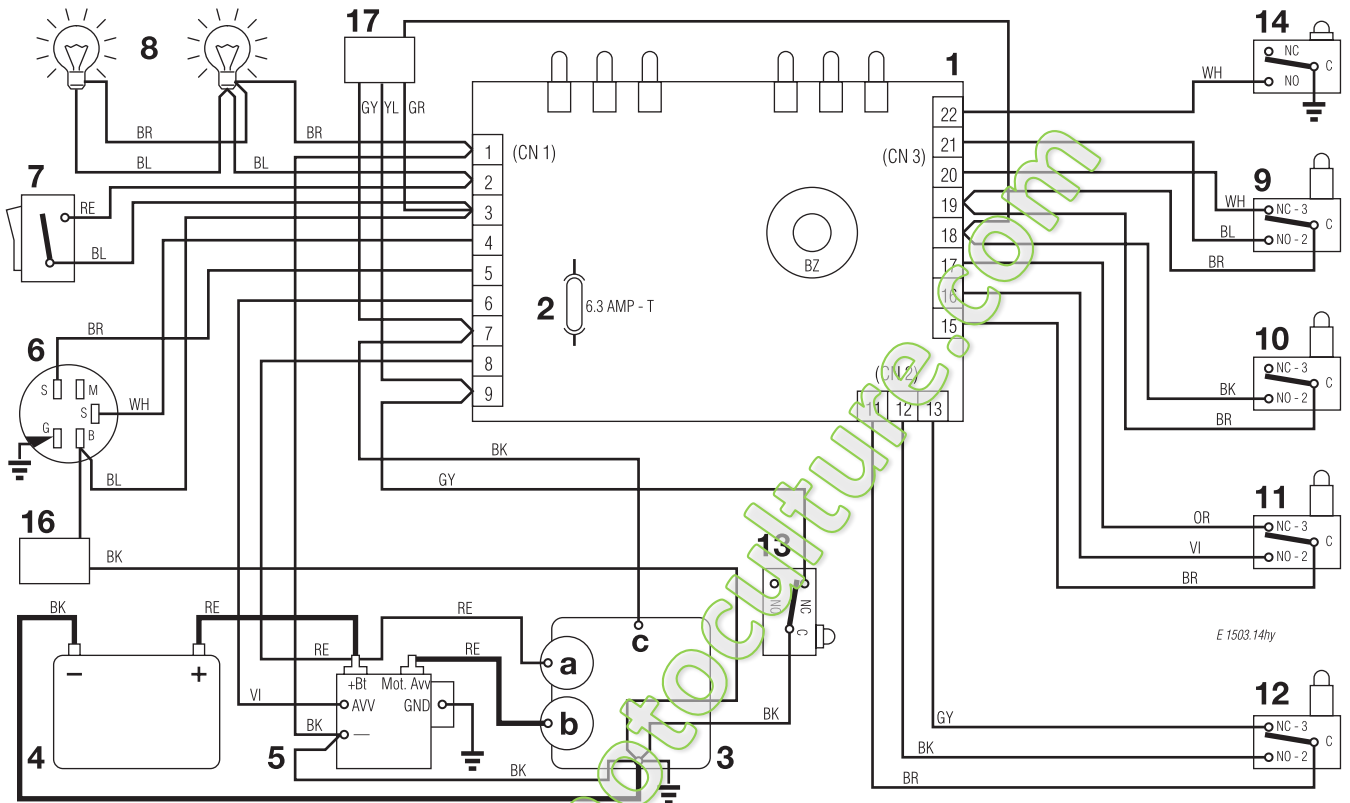

- |   |                                |                                   |                                      |
|---|--------------------------------|-----------------------------------|--------------------------------------|
| <b>1</b> SCHEDA<br>CON BUZZER           | ELECTRONIC CARD<br>WITH BUZZER | CARTE ELECTRONIQUE<br>AVEC BUZZER | ELECTRONISCHE KARTE<br>MIT BUZZER    |
| <b>2</b> FUSIBILE 6,3 Amp. T            | FUSE 6.3 Amp. T                | FUSIBLE 6,3 Amp. T                | SICHERUNG 6,3 Amp. T                 |
| <b>3</b> MOTORE                         | ENGINE                         | MOTEUR                            | MOTOR                                |
| <b>3a</b> Generatore                    | Generator                      | Generateur                        | Generator                            |
| <b>3b</b> Motorino avviamento           | Starter                        | Demarreur                         | Anlasser                             |
| <b>3c</b> Stop motore                   | Engine stop                    | Calage du moteur                  | Motor abstellung                     |
| <b>4</b> BATTERIA                       | BATTERY                        | BATTERIE                          | BATTERIE                             |
| <b>5</b> RELE AVVIAMENTO                | STARTER RELAY                  | RELAIS DE DEMARRAGE               | ANLASSER RELAIS                      |
| <b>6</b> INTERRUTTORE A CHIAVE          | ELECTROLOCK                    | INTERRUPTEUR D'ALLUMAGE           | SCHLÜSSELSCHALTER                    |
| <b>7</b> INTERRUTTORE FARI              | HEADLIGHT SWITCH               | INTERRUPTEUR PHARES               | LICHTSCHALTER                        |
| <b>8</b> FARI                           | HEADLIGHT                      | PHARES                            | LICHT                                |
| <b>9</b> MICROINTERRUTTORE LAME         | BLADES MICRO SWITCH            | MICRO INTERRUPTEUR LAMES          | MESSER MIKROSCHALTER                 |
| <b>10</b> MICROINTERRUTTORE FRENO       | BRAKE MICRO SWITCH             | MICRO INTERRUPTEUR FREIN          | BREMSE MIKROSCHALTER                 |
| <b>11</b> MICROINTERRUTTORE SEDILE      | SEAT MICRO SWITCH              | MICRO INTERRUPTEUR SIEGE          | SITZMIKROSCHALTER                    |
| <b>12</b> MICROINTERRUTTORE SACCO       | GRASSCATCHER MICRO SWITCH      | MICRO INTERRUPTEUR BAC            | GRASFANGEINRICHTUNG<br>MIKROSCHALTER |
| <b>13</b> MICROINTERRUTTORE FOLLE       | NEUTRAL MICROSWITCH            | MICRO INT. POINT MORT             | LEERLAUF MICROSCHALTER               |
| <b>14</b> MICROINTERRUTTORE SACCO PIENO | FULL GRASSCATCHER MICRO SWITCH | MICRO BAC PLEIN                   | VOLLKORB VORRICHTUNG                 |
| <b>16</b> CONTAORE (TCP)                | HOUR COUNTER (TCP)             | COMPTE-HEURS (TCP)                | BETRIEBESSTUNDENZÄHLER<br>(TCP)      |
| <b>17</b> INTERFACCIA                   | INTERFACE                      | INTERFACE                         | INTERFACE                            |

- COLORI CAVI**
- BK** NERO
  - BL** BLU
  - BR** MARRONE
  - GY** GRIGIO
  - GR** VERDE
  - OR** ARANCIONE
  - RE** ROSSO
  - VI** VIOLA
  - YG** GIALLO/VERDE
  - YL** GIALLO
  - WH** BIANCO

- CABLE COLOURS**
- BLACK**
  - BLUE**
  - BROWN**
  - GREY**
  - GREEN**
  - ORANGE**
  - RED**
  - VIOLET**
  - YELLOW/GREEN**
  - YELLOW**
  - WHITE**

- COULEUR CABLES**
- NOIR**
  - BLEU**
  - BUN**
  - GRIS**
  - VERT**
  - ORANGE**
  - ROUGE**
  - VIOLEY**
  - JAUNE/VERT**
  - JAUNE**
  - BLANC**

- KABEL FARBEN**
- SCHWARZ**
  - BLAU**
  - BRAUN**
  - GRAU**
  - GRÜN**
  - ORANGE**
  - ROT**
  - VIOLETT**
  - GELB/GRÜN**
  - GELB**
  - WEISS**

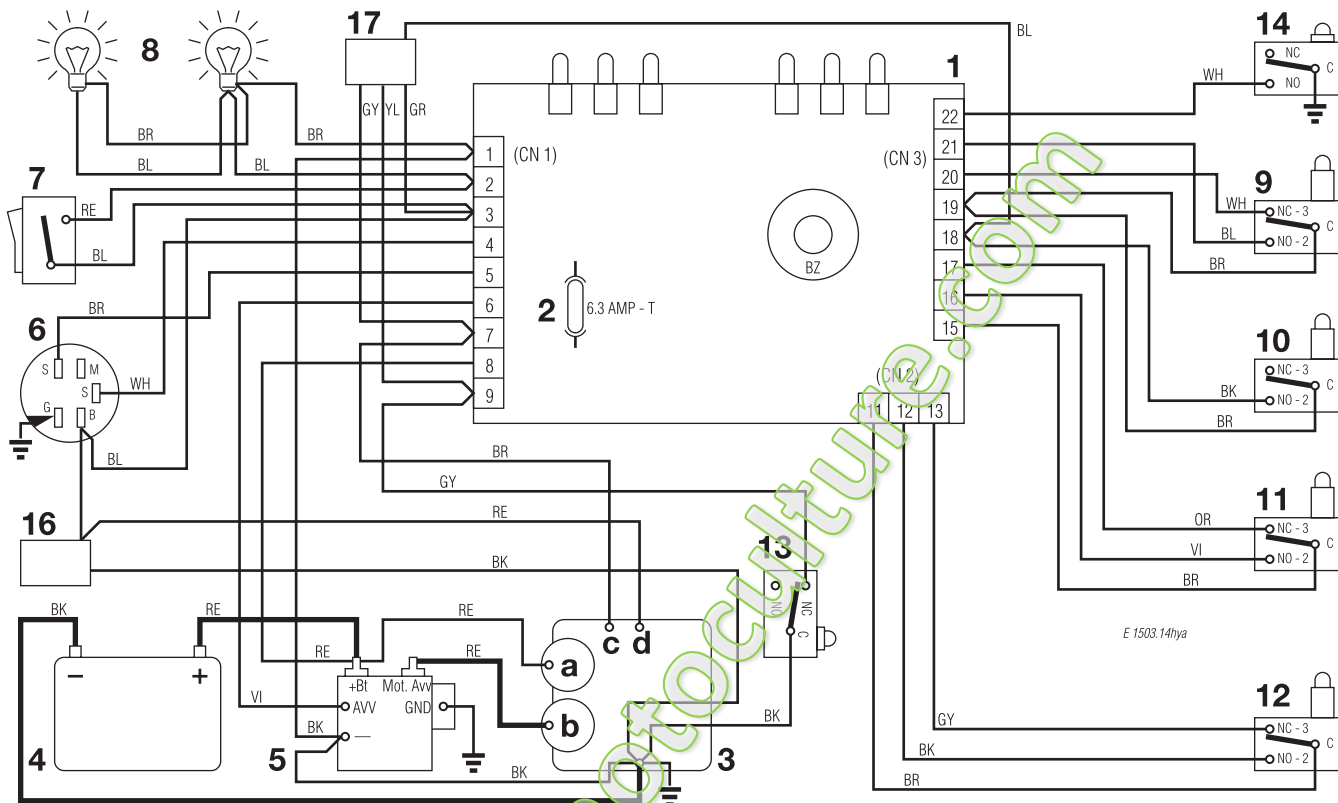

E 1503.14hya

<b>1</b>	SCHEDA CON BUZZER	ELECTRONIC CARD WITH BUZZER	CARTE ELECTRONIQUE AVEC BUZZER	ELECTRONISCHE KARTE MIT BUZZER
<b>2</b>	FUSIBILE 6,3 Amp. T	FUSE 6.3 Amp. T	FUSIBLE 6,3 Amp. T	SICHERUNG 6,3 Amp. T
<b>3</b>	MOTORE	ENGINE	MOTEUR	MOTOR
<b>3a</b>	Generatore	Generator	Generateur	Generator
<b>3b</b>	Motorino avviamento	Starter	Demarreur	Anlasser
<b>3c</b>	Stop motore	Engine stop	Calage du moteur	Motor abstellung
<b>3d</b>	Carburatore	Carburetor	Carburateur	Vergaser
<b>4</b>	BATTERIA	BATTERY	BATTERIE	BATTERIE
<b>5</b>	RELE AVVIAMENTO	STARTER RELAY	RELAIS DE DEMARRAGE	ANLASSER RELAIS
<b>6</b>	INTERRUTTORE A CHIAVE	ELECTROLOCK	INTERRUPTEUR D'ALLUMAGE	SCHLÜSSELSCHALTER
<b>7</b>	INTERRUTTORE FARI	HEADLIGHT SWITCH	INTERRUPTEUR PHARES	LICHTSCHALTER
<b>8</b>	FARI	HEADLIGHT	PHARES	LICHT
<b>9</b>	MICROINTERRUTTORE LAME	BLADES MICRO SWITCH	MICRO INTERRUPTEUR LAMES	MESSER MIKROSCHALTER
<b>10</b>	MICROINTERRUTTORE FRENO	BRAKE MICRO SWITCH	MICRO INTERRUPTEUR FREIN	BREMSE MIKROSCHALTER
<b>11</b>	MICROINTERRUTTORE SEDILE	SEAT MICRO SWITCH	MICRO INTERRUPTEUR SIEGE	SITZMIKROSCHALTER
<b>12</b>	MICROINTERRUTTORE SACCO	GRASSCATCHER MICRO SWITCH	MICRO INTERRUPTEUR BAC	GRASFANGEINRICHTUNG MIKROSCHALTER
<b>13</b>	MICROINTERRUTTORE FOLLE	NEUTRAL MICROSWITCH	MICRO INT. POINT MORT	LEERLAUF MICROSWITCHER
<b>14</b>	MICROINTERRUTTORE SACCO PIENO	FULL GRASSCATCHER MICRO SWITCH	MICRO BAC PLEIN	VOLLKORB VORRICHTUNG
<b>16</b>	CONTAORE (TCP)	HOUR COUNTER (TCP)	COMPTE-HEURS (TCP)	BETRIEBESSTUNDENZÄHLER (TCP)
<b>17</b>	INTERFACCIA	INTERFACE	INTERFACE	INTERFACE
	<b>COLORI CAVI</b>	<b>CABLE COLOURS</b>	<b>COULEUR CABLES</b>	<b>KABEL FARBEN</b>
	<b>BK</b> NERO	<b>BLACK</b>	<b>NOIR</b>	<b>SCHWARZ</b>
	<b>BL</b> BLU	<b>BLUE</b>	<b>BLEU</b>	<b>BLAU</b>
	<b>BR</b> MARRONE	<b>BROWN</b>	<b>BUN</b>	<b>BRAUN</b>
	<b>GY</b> GRIGIO	<b>GREY</b>	<b>GRIS</b>	<b>GRAU</b>
	<b>GR</b> VERDE	<b>GREEN</b>	<b>VERT</b>	<b>GRÜN</b>
	<b>OR</b> ARANCIONE	<b>ORANGE</b>	<b>ORANGE</b>	<b>ORANGE</b>
	<b>RE</b> ROSSO	<b>RED</b>	<b>ROUGE</b>	<b>ROT</b>
	<b>VI</b> VIOLA	<b>VIOLET</b>	<b>VIOLEY</b>	<b>VIOLETT</b>
	<b>YG</b> GIALLO/VERDE	<b>YELLOW/GREEN</b>	<b>JAUNE/VERT</b>	<b>GELB/GRÜN</b>
	<b>YL</b> GIALLO	<b>YELLOW</b>	<b>JAUNE</b>	<b>GELB</b>
	<b>WH</b> BIANCO	<b>WHITE</b>	<b>BLANC</b>	<b>WEISS</b>

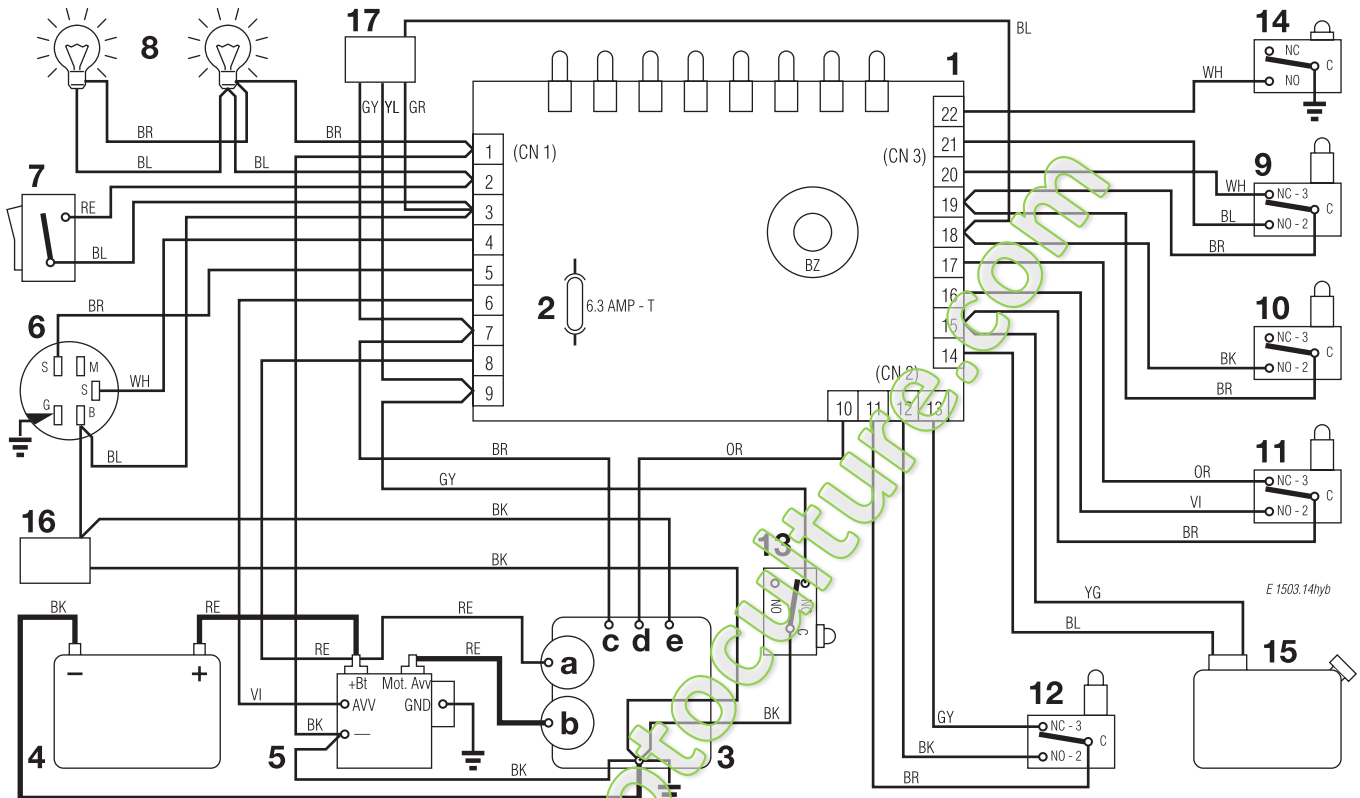

1	SCHEDA CON BUZZER	ELECTRONIC CARD WITH BUZZER	CARTE ELECTRONIQUE AVEC BUZZER	ELECTRONISCHE KARTE MIT BUZZER
2	FUSIBILE 6,3 Amp. T	FUSE 6,3 Amp. T	FUSIBLE 6,3 Amp. T	SICHERUNG 6,3 Amp. T
3	MOTORE	ENGINE	MOTEUR	MOTOR
3a	Generatore	Generator	Genérateur	Generator
3b	Motorino avviamento	Starter	Demarreur	Anlasser
3c	Stop motore	Engine stop	Calage du moteur	Motor abstellung
3d	Olio	Oil	Huile	Öil
3e	Carburatore	Carburetor	Carburateur	Vergaser
4	BATTERIA	BATTERY	BATTERIE	BATTERIE
5	RELE AVVIAMENTO	STARTER RELAY	RELAIS DE DEMARRAGE	ANLASSER RELAIS
6	INTERRUTTORE A CHIAVE	ELECTROLOCK	INTERRUPTEUR D'ALLUMAGE	SCHLÜSSELSCHALTER
7	INTERRUTTORE FARI	HEADLIGHT SWITCH	INTERRUPTEUR PHARES	LICHTSCHALTER
8	FARI	HEADLIGHT	PHARES	LICHT
9	MICROINTERRUTTORE LAME	BLADES MICRO SWITCH	MICRO INTERRUPTEUR LAMES	MESSER MIKROSCHALTER
10	MICROINTERRUTTORE FRENO	BRAKE MICRO SWITCH	MICRO INTERRUPTEUR FREIN	BREMSE MIKROSCHALTER
11	MICROINTERRUTTORE SEDILE	SEAT MICRO SWITCH	MICRO INTERRUPTEUR SIEGE	SITZMIKROSCHALTER
12	MICROINTERRUTTORE SACCO	GRASSCATCHER MICRO SWITCH	MICRO INTERRUPTEUR BAC	GRASFANGEinRICHTUNG MIKROSCHALTER
13	MICROINTERRUTTORE FOLLE	NEUTRAL MICROSWITCH	MICRO INT. POINT MORT	LEERLAUF MICROSWITCH
14	MICROINTERRUTTORE SACCO PIENO	FULL GRASSCATCHER MICRO SWITCH	MICRO BAC PLEIN	VOLLKORB VORRICHTUNG
15	SERBATOIO	TANK	RESERVIOR	TANK
16	CONTAORE (TCP)	HOUR COUNTER (TCP)	COMPTE-HEURS (TCP)	BETRIEBESSTUNDENZÄHLER (TCP)
17	INTERFACCIA	INTERFACE	INTERFACE	INTERFACE

**COLORI CAVI**

<b>BK</b>	NERO
<b>BL</b>	BLU
<b>BR</b>	MARRONE
<b>GY</b>	GRIGIO
<b>GR</b>	VERDE
<b>OR</b>	ARANCIONE
<b>RE</b>	ROSSO
<b>VI</b>	VIOLA
<b>YG</b>	GIALLO/VERDE
<b>YL</b>	GIALLO
<b>WH</b>	BIANCO

**CABLE COLOURS**

<b>BLACK</b>
<b>BLUE</b>
<b>BROWN</b>
<b>GREY</b>
<b>GREEN</b>
<b>ORANGE</b>
<b>RED</b>
<b>VIOLET</b>
<b>YELLOW/GREEN</b>
<b>YELLOW</b>
<b>WHITE</b>

**COULEUR CABLES**

<b>NOIR</b>
<b>BLEU</b>
<b>BUN</b>
<b>GRIS</b>
<b>VERT</b>
<b>ORANGE</b>
<b>ROUGE</b>
<b>VIOLEY</b>
<b>JAUNE/VERT</b>
<b>JAUNE</b>
<b>BLANC</b>

**KABEL FARBEN**

<b>SCHWARZ</b>
<b>BLAU</b>
<b>BRAUN</b>
<b>GRAU</b>
<b>GRÜN</b>
<b>ORANGE</b>
<b>ROT</b>
<b>VIOLETT</b>
<b>GELB/GRÜN</b>
<b>GELB</b>
<b>WEISS</b>